

Series 222L

6.2 x 6.2mm IP67 Rated Tactile Switch

- Surface mount gull wing and J-bend terminal configurations
- Compatible with IR reflow, and manual soldering
- Variety of operating force & actuator height options
- IP67 protection
- Silicone rubber actuator
- Long life
- Excellent tactile feel



Ordering Information

Series	Terminal Type	Actuating Direction	Actuator Height "L"	Actuation Force	Packaging										
222L	M	V	A	A	R										
	<table border="1"> <thead> <tr> <th>Code</th> <th>Spec.</th> </tr> </thead> <tbody> <tr> <td>M</td> <td>Surface mount gull wing</td> </tr> <tr> <td>J</td> <td>Surface mount J bend</td> </tr> </tbody> </table>	Code	Spec.	M	Surface mount gull wing	J	Surface mount J bend			<table border="1"> <thead> <tr> <th>Code</th> <th>Spec.</th> </tr> </thead> <tbody> <tr> <td>A</td> <td>225 gf, blue</td> </tr> </tbody> </table>	Code	Spec.	A	225 gf, blue	
Code	Spec.														
M	Surface mount gull wing														
J	Surface mount J bend														
Code	Spec.														
A	225 gf, blue														
		<table border="1"> <thead> <tr> <th>Code</th> <th>Spec.</th> </tr> </thead> <tbody> <tr> <td>V</td> <td>Vertical</td> </tr> </tbody> </table>	Code	Spec.	V	Vertical									
Code	Spec.														
V	Vertical														
			<table border="1"> <thead> <tr> <th>Code</th> <th>Spec.</th> </tr> </thead> <tbody> <tr> <td>A</td> <td>4.3mm</td> </tr> </tbody> </table>	Code	Spec.	A	4.3mm								
Code	Spec.														
A	4.3mm														
				<table border="1"> <thead> <tr> <th>Code</th> <th>Spec.</th> </tr> </thead> <tbody> <tr> <td>R</td> <td>Tape & reel packaging</td> </tr> </tbody> </table>	Code	Spec.	R	Tape & reel packaging							
Code	Spec.														
R	Tape & reel packaging														

Electrical Specifications

Parameter	Conditions & Remarks	Min	Max	Unit
Contact Resistance			100	milliohms
Insulation Resistance	Between insulated terminals	1000		megohms
Dielectric Strength	250 VAC between adjacent switches		1	minute
Nonswitching Rating			50 or 32	mA or VDC

Mechanical and Environmental

Soldering	Maximum reflow temperature, 260°C for 5 seconds Maximum manual temperature, 350°C for 3 seconds
RoHS	Lead-Free. Fully compliant to RoHS Directive 2011/65/EU
Operating Force	225±75 gf
Actuation Life	300,000 cycles
Actuator Strength	3 Kgf maximum
Travel	0.3±0.2mm
Packaging	Standard tape and reel packaging
Operating Temperature Range	-40°C to +85°C
Storage Temperature Range	-40°C to +85°C
Waterproof Grade	IP67

Soldering Profile

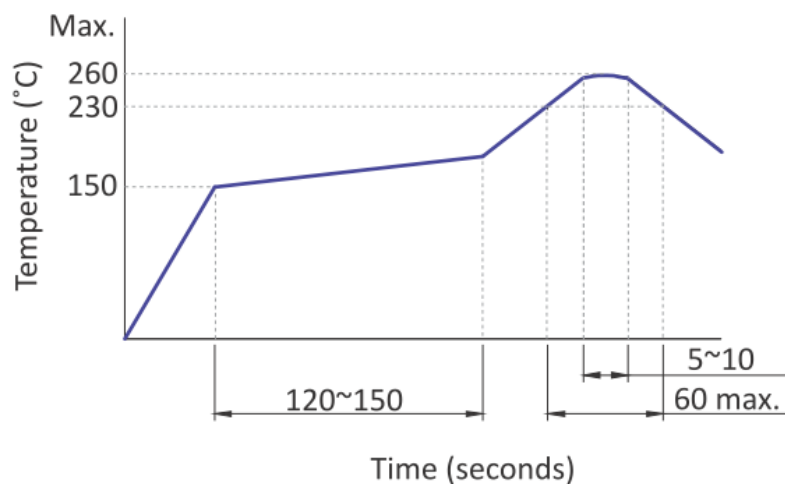

Mechanical Specifications

Figure 1 – 222LMA, Surface Mount Gull Wing, Actuator Height 4.3mm

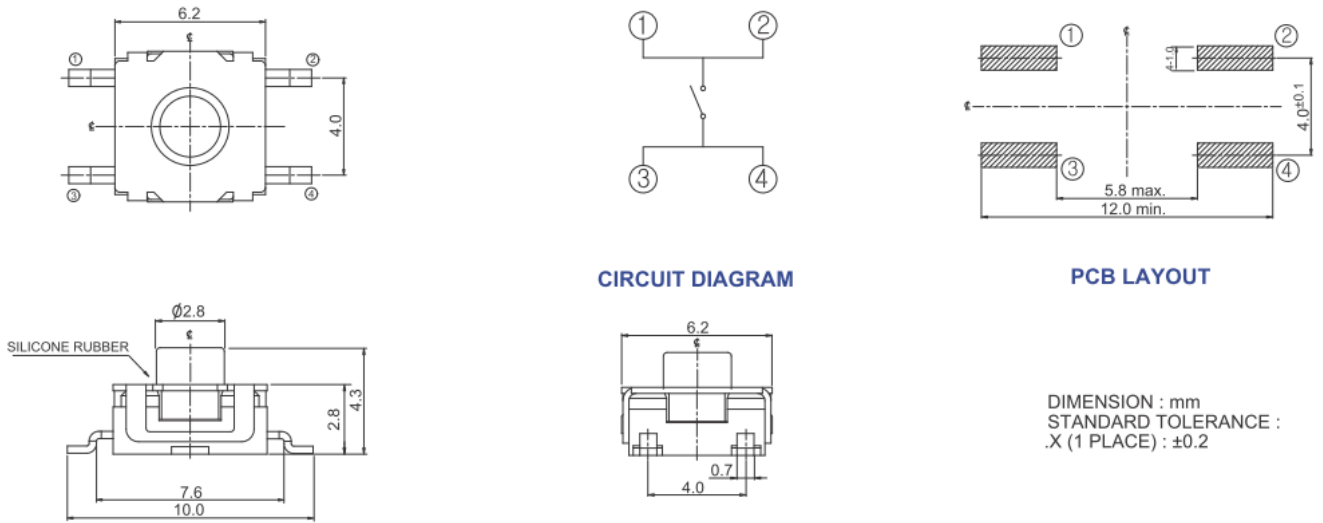
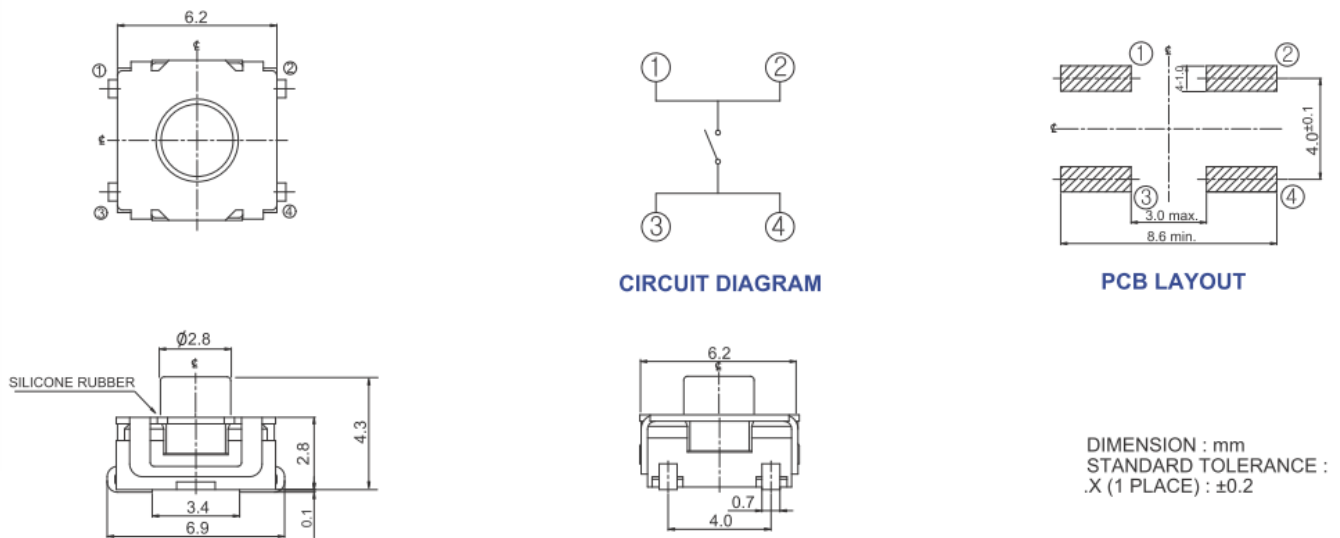

Figure 2 – 222LJA, Surface Mount J Bend, Actuator Height 4.3mm



Packing: Tape and Reel

Surface Mount Gull Wing/J-Bend, Actuator Height 4.3mm

The packing specifications:

1. Structure and materials:

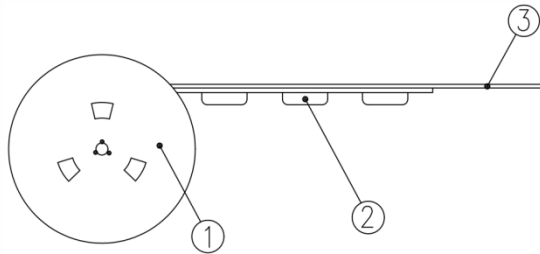

No	PART NAME	MATERIAL
①	REEL	POLYSTYRENE
②	CARRIER TAPE	POLYSTYRENE
③	COVER TAPE	POLYESTER

2. Packing quantity: 1,000 pcs/reel
3. More than 10 empty pockets should remain at each end of the carrier tape for each reel.
4. Shortage of less than 10 pcs a reel is acceptable but no more than 3 consecutive empty pockets are allowed.
5. Stripping strength of cover tape is between 10 gf to 130 gf and stripping angle should be within 165°~180°.
6. The product in the pocket of carrier tape should be placed in a specified correct position.
7. Tape and reel per EIA-481.
8. Dimensions:

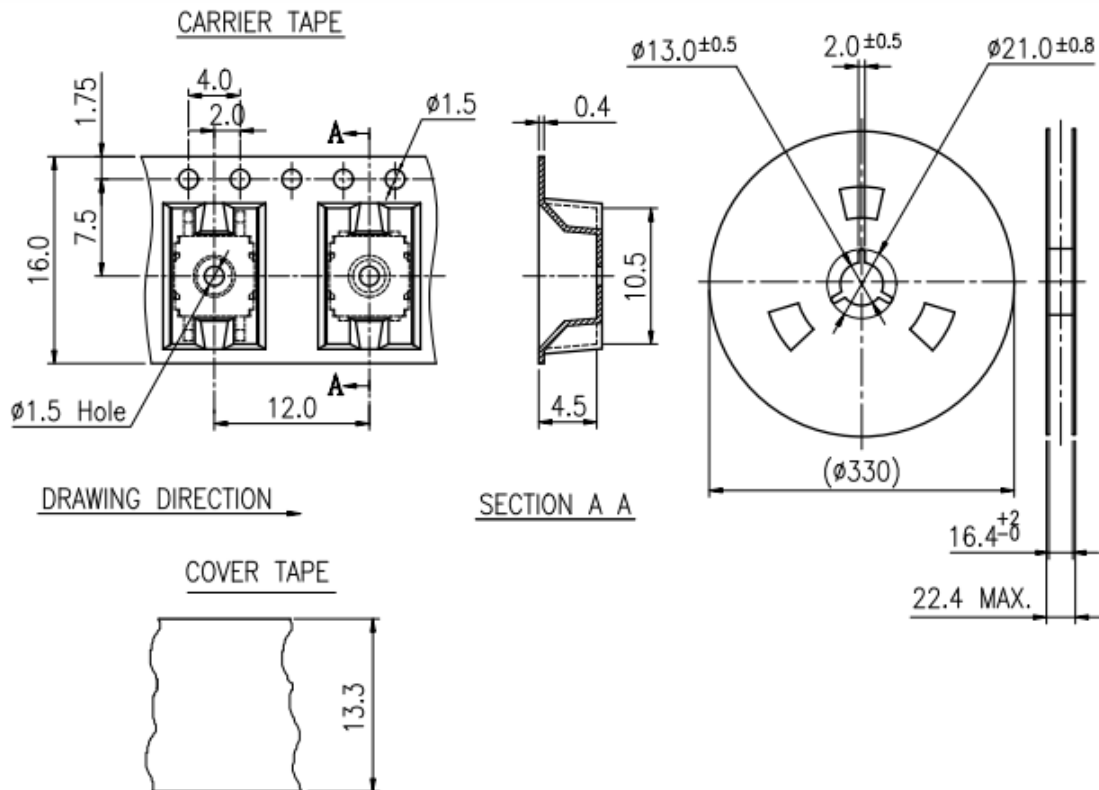

Данный компонент на территории Российской Федерации

Вы можете приобрести в компании MosChip.

Для оперативного оформления запроса Вам необходимо перейти по данной ссылке:

<http://moschip.ru/get-element>

Вы можете разместить у нас заказ для любого Вашего проекта, будь то серийное производство или разработка единичного прибора.

В нашем ассортименте представлены ведущие мировые производители активных и пассивных электронных компонентов.

Нашей специализацией является поставка электронной компонентной базы двойного назначения, продукции таких производителей как XILINX, Intel (ex.ALTERA), Vicor, Microchip, Texas Instruments, Analog Devices, Mini-Circuits, Amphenol, Glenair.

Сотрудничество с глобальными дистрибьюторами электронных компонентов, предоставляет возможность заказывать и получать с международных складов практически любой перечень компонентов в оптимальные для Вас сроки.

На всех этапах разработки и производства наши партнеры могут получить квалифицированную поддержку опытных инженеров.

Система менеджмента качества компании отвечает требованиям в соответствии с ГОСТ Р ИСО 9001, ГОСТ РВ 0015-002 и ЭС РД 009

Офис по работе с юридическими лицами:

105318, г.Москва, ул.Щербаковская д.3, офис 1107, 1118, ДЦ «Щербаковский»

Телефон: +7 495 668-12-70 (многоканальный)

Факс: +7 495 668-12-70 (доб.304)

E-mail: info@moschip.ru

Skype отдела продаж:

moschip.ru

moschip.ru_4

moschip.ru_6

moschip.ru_9