

# AZ2700

## 30 AMP POWER RELAY

### FEATURES

- Low cost
- 30 Amp switching
- Class B insulation system standard, Class F available
- Quick connect terminals
- 4 kV dielectric
- Standard (2.4 mm) and wide contact gap (3.0 mm) available
- UL, CUR file E44211
- TÜV R50031999



### CONTACTS

<b>Arrangement</b>	SPST (1 Form X) DPST (2 Form X)
<b>Ratings</b>	Resistive load: Max. switched power: 840 W or 8310 VA Max. switched current: 30 A Max. switched voltage: 150* VDC or 400 VAC  *Note: If switching voltage is greater than 30VDC, special precautions must be taken. Please contact the factory.
<b>Rated Load UL, CUR</b>	30 A at 277 VAC res. 30k cycles [1] 1.5 HP at 120 VAC [1] 3 HP at 240 VAC [1] TV-10 at 120 VAC [1] 30 A at 277 VAC res. 70k cycles [2] 3 HP at 240 VAC 100k cycles [2] 10 A at 120 VAC tungsten load, 10k cycles [2]
<b>TÜV</b>	27 A at 240 VAC, cos phi = .8, 100k cycles [1]  [1] silver cadmium oxide, [2] silver tin oxide
<b>Material</b>	Silver cadmium oxide, silver tin oxide
<b>Resistance</b>	< 100 milliohms initially (24 V, 1 A voltage drop method)

### COIL

<b>Power At Pickup Voltage (typical)</b>	1.2 VA (AC)
<b>Max. Continuous Dissipation</b>	3.8 W at 20°C (68°F) ambient
<b>Temperature Rise</b>	50°C (90°F) at nominal coil voltage
<b>Temperature</b>	Max. 130°C (266°F) - Class B Max. 155°C (311°F) - Class F

### GENERAL DATA

<b>Life Expectancy Mechanical Electrical</b>	Minimum operations 1 x 10 <sup>6</sup> 1 x 10 <sup>5</sup> at 30 A 120 VAC Res.
<b>Operate Time (max)</b>	30 ms at nominal coil voltage
<b>Release Time (max)</b>	30 ms at nominal coil voltage (with no coil suppression)
<b>Dielectric Strength (at sea level for 1 min.)</b>	4000 Vrms coil to contact 2000 Vrms between open contacts
<b>Insulation Resistance</b>	1000 megohms min. at 20°C, 500 VDC, 50% RH
<b>Dropout</b>	Greater than 5% of nominal coil voltage (DC) Greater than 15% of nominal coil voltage (AC)
<b>Ambient Temperature Operating Storage</b>	At nominal coil voltage -40°C (-40°F) to 85°C (185°F) - Class B -40°C (-40°F) to 105°C (221°F) - Class F -40°C (-40°F) to 130°C (266°F) - Class B -40°C (-40°F) to 155°C (311°F) - Class F
<b>Vibration</b>	0.062" DA at 10-55 Hz
<b>Shock Operating Non-Operating</b>	10 g, 11 ms, 1/2 sine (no false operation) 100 g, 11 ms, 1/2 sine (no damage)
<b>Enclosure</b>	P.B.T. polyester
<b>Terminals</b>	Tinned copper alloy, Quick connect tabs Note: Allow suitable slack on leads when wiring, and do not subject the terminals to excessive force.
<b>Weight</b>	120 grams

### NOTES

1. All values at 20°C (68°F).
2. Relay may pull in with less than "Must Operate" value.
3. Specifications subject to change without notice.



**AMERICAN ZETTLER, INC.** [www.azettler.com](http://www.azettler.com)

75 COLUMBIA • ALISO VIEJO, CA 92656 • PHONE: (949) 831-5000 • FAX: (949) 831-8642 • E-MAIL: SALES@AZETTLER.COM

# AZ2700

## RELAY ORDERING DATA

COIL SPECIFICATIONS – DC COIL				ORDER NUMBER*	
Nominal Coil VDC	Must Operate VDC	Max. Continuous VDC	Coil Resistance $\pm 10\%$	1 Form X	2 Form X
3	2.25	4.2	4.7	AZ2700-1A-3D	AZ2700-2A-3D
6	4.50	8.4	18.8	AZ2700-1A-6D	AZ2700-2A-6D
12	9.00	16.8	75	AZ2700-1A-12D	AZ2700-2A-12D
24	18.00	33.7	300	AZ2700-1A-24D	AZ2700-2A-24D
48	36.0	67.5	1200	AZ2700-1A-48D	AZ2700-2A-48D
100	75.0	140.5	5200	AZ2700-1A-100D	AZ2700-2A-100D
110	82.5	154.7	6300	AZ2700-1A-110D	AZ2700-2A-110D
200	150.0	282.4	21000	AZ2700-1A-200D	AZ2700-2A-200D

COIL SPECIFICATIONS – AC COIL				ORDER NUMBER*	
Nominal Coil VAC	Must Operate VAC	Max. Continuous VAC	Coil Current mA $\pm 10\%$	1 Form X	2 Form X
6	4.80	6.6	319	AZ2700-1A-6A	AZ2700-2A-6A
12	9.60	13.2	160	AZ2700-1A-12A	AZ2700-2A-12A
24	19.2	26.4	80	AZ2700-1A-24A	AZ2700-2A-24A
48	38.4	52.8	40	AZ2700-1A-48A	AZ2700-2A-48A
120	96.0	132.0	23	AZ2700-1A-120A	AZ2700-2A-120A
220	176.0	242.0	10	AZ2700-1A-220A	AZ2700-2A-220A
240	192.0	264.0	9.2	AZ2700-1A-240A	AZ2700-2A-240A

\*For silver tin oxide add suffix "T" (UL approved for 1 Form X version only). For wide contact gap add "W". For Class F add suffix "F".

## MECHANICAL DATA

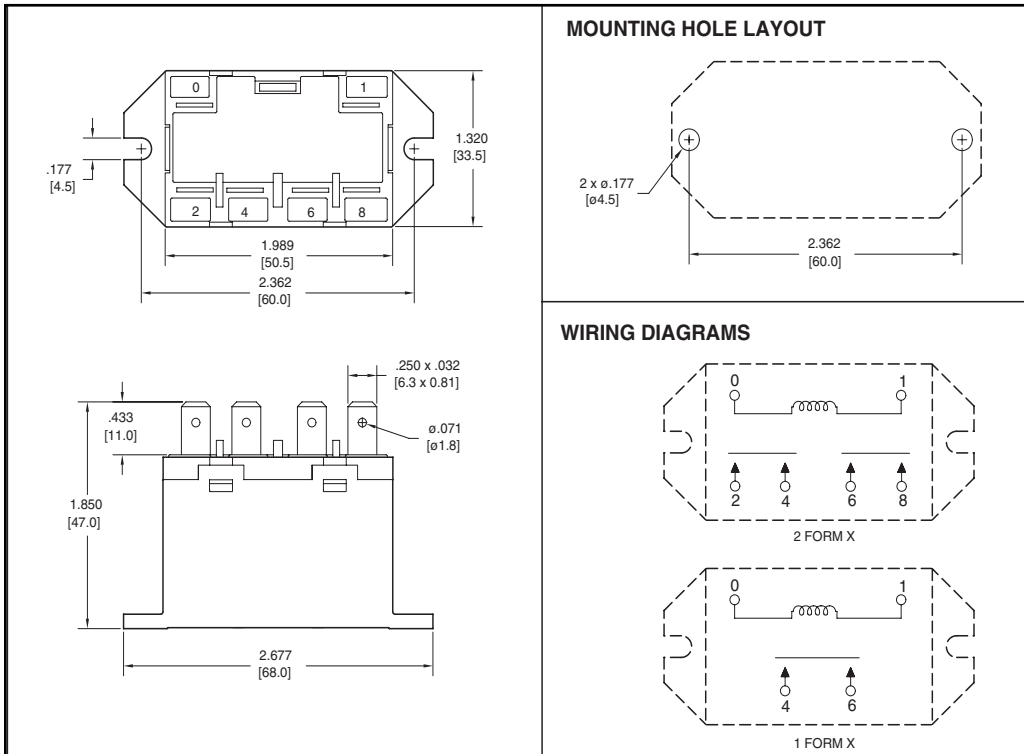

Dimensions in inches with metric equivalents in parentheses. Tolerance:  $\pm .010$ "



**AMERICAN ZETTLER, INC.**

[www.azettler.com](http://www.azettler.com)

75 COLUMBIA • ALISO VIEJO, CA 92656 • PHONE: (949) 831-5000 • FAX: (949) 831-8642 • E-MAIL: SALES@AZETTLER.COM

## Данный компонент на территории Российской Федерации

### Вы можете приобрести в компании MosChip.

Для оперативного оформления запроса Вам необходимо перейти по данной ссылке:

<http://moschip.ru/get-element>

Вы можете разместить у нас заказ для любого Вашего проекта, будь то серийное производство или разработка единичного прибора.

В нашем ассортименте представлены ведущие мировые производители активных и пассивных электронных компонентов.

Нашей специализацией является поставка электронной компонентной базы двойного назначения, продукции таких производителей как XILINX, Intel (ex.ALTERA), Vicor, Microchip, Texas Instruments, Analog Devices, Mini-Circuits, Amphenol, Glenair.

Сотрудничество с глобальными дистрибьюторами электронных компонентов, предоставляет возможность заказывать и получать с международных складов практически любой перечень компонентов в оптимальные для Вас сроки.

На всех этапах разработки и производства наши партнеры могут получить квалифицированную поддержку опытных инженеров.

Система менеджмента качества компании отвечает требованиям в соответствии с ГОСТ Р ИСО 9001, ГОСТ РВ 0015-002 и ЭС РД 009

### Офис по работе с юридическими лицами:

105318, г.Москва, ул.Щербаковская д.3, офис 1107, 1118, ДЦ «Щербаковский»

Телефон: +7 495 668-12-70 (многоканальный)

Факс: +7 495 668-12-70 (доб.304)

E-mail: [info@moschip.ru](mailto:info@moschip.ru)

Skype отдела продаж:

moschip.ru

moschip.ru\_4

moschip.ru\_6

moschip.ru\_9