

# TCS3430

## Color and ALS Sensor

### General Description

The device features advanced digital Ambient Light Sensing (ALS) and CIE 1931 Tristimulus Color Sensing (XYZ). Each of the channels has a filter to control its optical response, which allows the device to accurately measure ambient light and sense color. These measurements are used to calculate chromaticity, illuminance and color temperature, all of which are used to support various potential applications.

*Ordering Information and Content Guide appear at end of datasheet.*

### Key Benefits & Features

The benefits and features of the TCS3430 Color and ALS Sensor are listed below:

**Figure 1:**  
Added Value of Using TCS3430

Benefits	Features
<ul style="list-style-type: none"> <li>Improves ALS responsiveness of the system</li> </ul>	<ul style="list-style-type: none"> <li>Capable of <math>\pm 10\%</math> illuminance and correlated color temperature accuracy</li> </ul>
<ul style="list-style-type: none"> <li>Reduces board space requirements and enables low-profile system design</li> </ul>	<ul style="list-style-type: none"> <li>Small footprint and low profile package: 2.41mm x 1.75mm x 1.00mm</li> </ul>
<ul style="list-style-type: none"> <li>Improves ALS response for more accurate measurement of lighting environment</li> </ul>	<ul style="list-style-type: none"> <li>Advanced interference filter technology</li> </ul>
<ul style="list-style-type: none"> <li>Enables accurate color and ALS sensing under varying lighting conditions and behind dark glass</li> </ul>	<ul style="list-style-type: none"> <li>Wide dynamic range and high sensitivity</li> </ul>
<ul style="list-style-type: none"> <li>Enables accurate color temperature calculations and ambient light sensing</li> </ul>	<ul style="list-style-type: none"> <li>XYZ tristimulus filters</li> <li>Programmable gain and integration time</li> </ul>
<ul style="list-style-type: none"> <li>Low power consumption</li> </ul>	<ul style="list-style-type: none"> <li>1.8V supply voltage and I<sup>2</sup>C bus</li> </ul>

### Applications

The TCS3430 applications include:

- Display management
- Camera image correction and enhancement
- Color sensing
- Ambient light sensing
- Optical identification
- Color matching

### Block Diagram

The functional blocks of this device are shown below:

Figure 2:  
TCS3430 Block Diagram

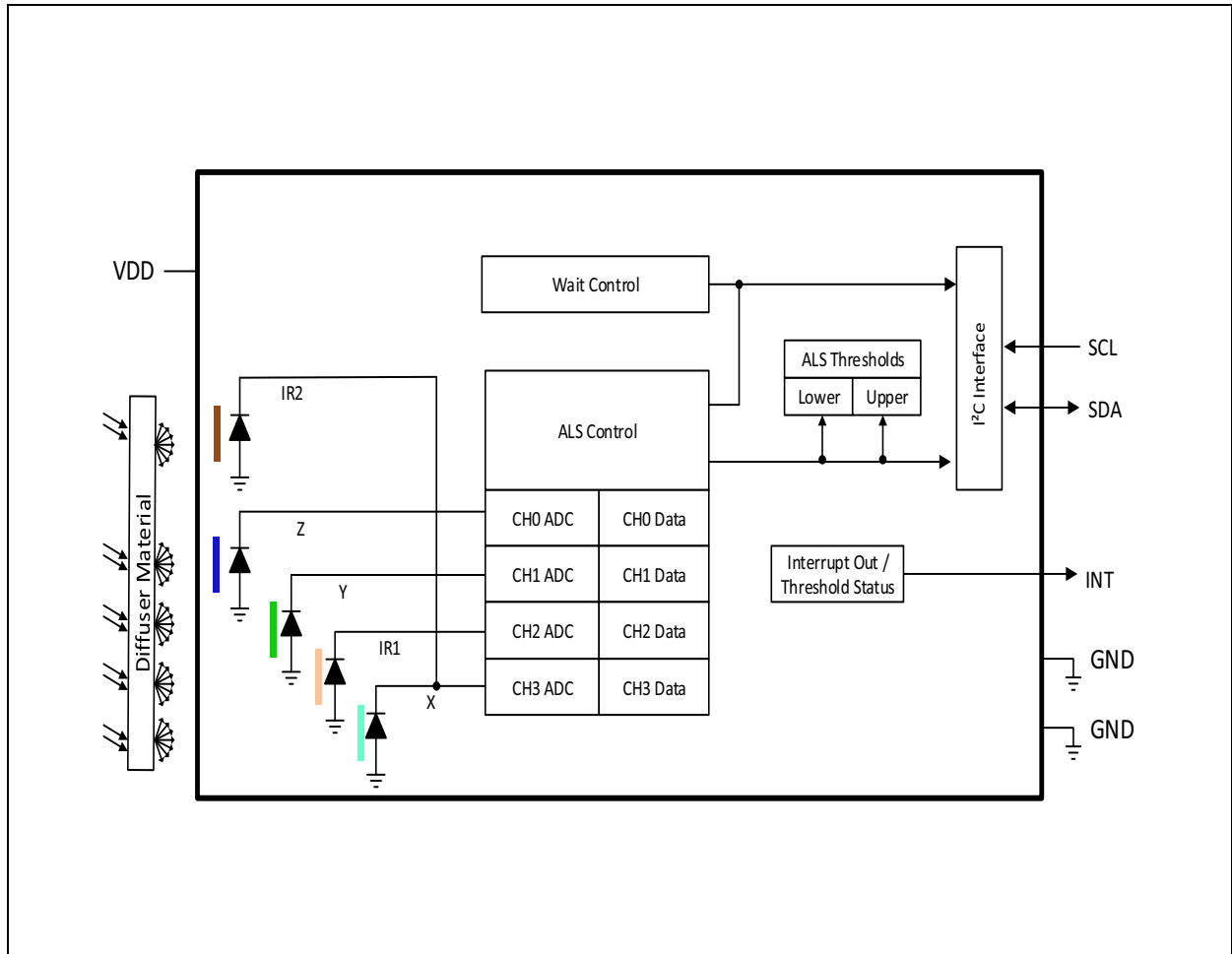

## Pin Assignment

**Figure 3:**  
TCS3430 Pinout (Top View)

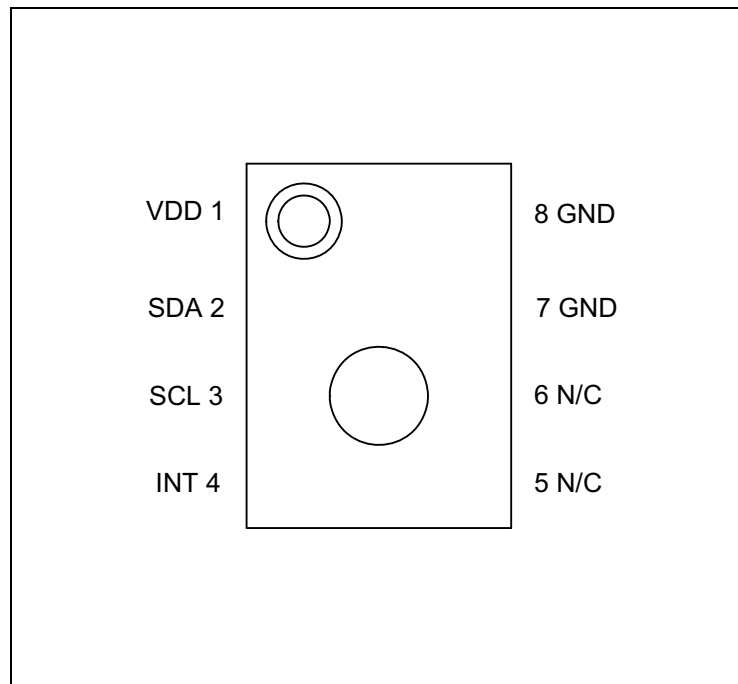

**Figure 4:**  
Pin Description

Pin Number	Pin Name	Description
1	VDD	Supply voltage
2	SDA	I <sup>2</sup> C serial data I/O terminal
3	SCL	I <sup>2</sup> C serial clock input terminal
4	INT	Interrupt. Open drain output (active low)
5	N/C	No connection. May be connected to Ground or not connected.
6	N/C	No connection. May be connected to Ground or not connected.
7	GND	Ground. All voltages are referenced to GND
8	GND	Ground. All voltages are referenced to GND

## Absolute Maximum Ratings

Stresses beyond those listed under [Absolute Maximum Ratings](#) may cause permanent damage to the device. These are stress ratings only. Functional operation of the device at these or any other conditions beyond those indicated under [Recommended Operating Conditions](#) is not implied. Exposure to absolute maximum rating conditions for extended periods may affect device reliability.

**Figure 5:**  
Absolute Maximum Ratings

Symbol	Parameter	Min	Max	Units
$V_{DD}$	Supply voltage	-0.3	2.2	V
$V_{IO}$	Digital I/O terminal voltage	-0.3	3.6	V
$I_{IO}$	Output terminal current	-1	20	mA
$T_{STRG}$	Storage temperature range	-40	85	°C
$T_J$	Junction temperature range	-40	90	°C
$ESD_{HBM}$	Electrostatic discharge HBM (JS-001-2014)	±2000		V
$ESD_{CDM}$	Electrostatic discharge CDM JEDEC JESD22-C101F Oct 2013	±500		V
$I_{SCR}$	Input current (latch up immunity) JEDEC JESD78D Nov 2011	CLASS 2		

## Electrical Characteristics

**Figure 6:**  
Recommended Operating Conditions

Symbol	Parameter	Min	Typ	Max	Units
$V_{DD}$	Supply voltage	1.7	1.8	2.0	V
$T_A$	Operating free-air temperature <sup>(1)</sup>	-30		85	°C

**Note(s):**

1. While the device is operational across the temperature range, performance will vary with temperature. Operational characteristics are at 25°C, unless otherwise noted.

**Figure 7:**  
Operating Characteristics,  $V_{DD} = 1.8\text{ V}$ ,  $T_A = 25^\circ\text{C}$  (unless otherwise noted)

Symbol	Parameter	Conditions	Min	Typ	Max	Units
$f_{OSC}$	Oscillator frequency			8.1		MHz
$I_{DD}$	Supply current <sup>(1)</sup>	Active ALS state (PON=AEN=1) <sup>(2)</sup>		100	150	$\mu\text{A}$
		Idle state (PON=1, AEN=0) <sup>(3)</sup>		30	60	
		Sleep State <sup>(4)</sup>		0.7	5.0	$\mu\text{A}$
$V_{OL}$	INT, SDA output low voltage	6 mA sink current			0.6	V
$I_{LEAK}$	Leakage current, SDA, SCL, INT, pins		-5		5	$\mu\text{A}$
$V_{IH}$	SCL, SDA input high voltage		1.26			V
$V_{IL}$	SCL, SDA input low voltage				0.54	V

**Note(s):**

- Values are shown at the VDD pin.
- This parameter indicates the supply current during periods of ALS integration. If Wait is enabled (WEN=1), the supply current is lower during the Wait period.
- Idle state occurs when PON=1 and all functions are not enabled.
- Sleep state occurs when PON = 0 and I<sup>2</sup>C bus is idle. If Sleep state has been entered as the result of operational flow, SAI = 1, PON will remain high.

**Figure 8:**  
**Optical Characteristics**

Parameter	Channel	Light Source	Min	Typ	Max	Units
Irradiance Responsivity 16x gain, 400ms <sup>(1)</sup>	X	Warm White LED (2700K, 25 $\mu\text{W}/\text{cm}^2$ )	58	74	90	counts/ ( $\mu\text{W}/\text{cm}^2$ )
	Y		56	62	70	
	Z		6.5	10.3	14	
	IR1	Far Red LED ( $\lambda = 730\text{nm}$ , 11.6 $\mu\text{W}/\text{cm}^2$ )	90	135	180	
	IR2	IR LED ( $\lambda = 950\text{nm}$ , 41.8 $\mu\text{W}/\text{cm}^2$ )	90	160	230	

**Note(s):**

1. Tested using collimated light sources.

**Figure 9:**  
**Filter Characteristics**

Symbol	Parameter	Min	Typ	Max	Units
$\lambda_{X1}$	Peak 1 wavelength of channel X	427	437	447	nm
$\lambda_{X2}$	Peak 2 wavelength of channel X	564	574	584	nm
$\lambda_Y$	Peak wavelength of channel Y	527	537	547	nm
$\lambda_Z$	Peak wavelength of channel Z	424	434	444	nm
FWHM_X1	Full width at half maximum of channel X peak 1	45	55	65	nm
FWHM_X2	Full width at half maximum of channel X peak 2	83	93	103	nm
FWHM_Y	Full width at half maximum of channel Y	92	102	112	nm
FWHM_Z	Full width at half maximum of channel Z	53	63	73	nm
T50L_IR1	Lower edge of IR1 at 50% of transition	672	687	702	nm
T50H_IR1	Higher edge of IR1 at 50% of transition	815	830	845	nm
T50_IR2	At 50% of transition of IR2	812	827	842	nm

**Note(s):**

1. Filter parameters are measured on a production ongoing sample basis using diffused light.

**Figure 10:**  
**ALS Operating Characteristics, VDD = 1.8 V, T<sub>A</sub> = 25°C, AGAIN = 16x, ATIME = 0x09 (27ms)**  
 (unless otherwise noted)

Parameter	Conditions	Min	Typ	Max	Units
Integration time step size		2.64	2.78	2.92	ms
Dark ADC count value	Ee = 0 μW/cm <sup>2</sup> AGAIN: 64x ATIME: 100ms (0x23)	0	1	3	counts
Gain scaling, relative to 1x gain setting	AGAIN: 4x		4		
	AGAIN: 16x		16		
	AGAIN: 64x		66		
	AGAIN: 128x		137		
ADC noise	AGAIN: 16x		0.005		% full scale

**Figure 11:**  
Spectral Response

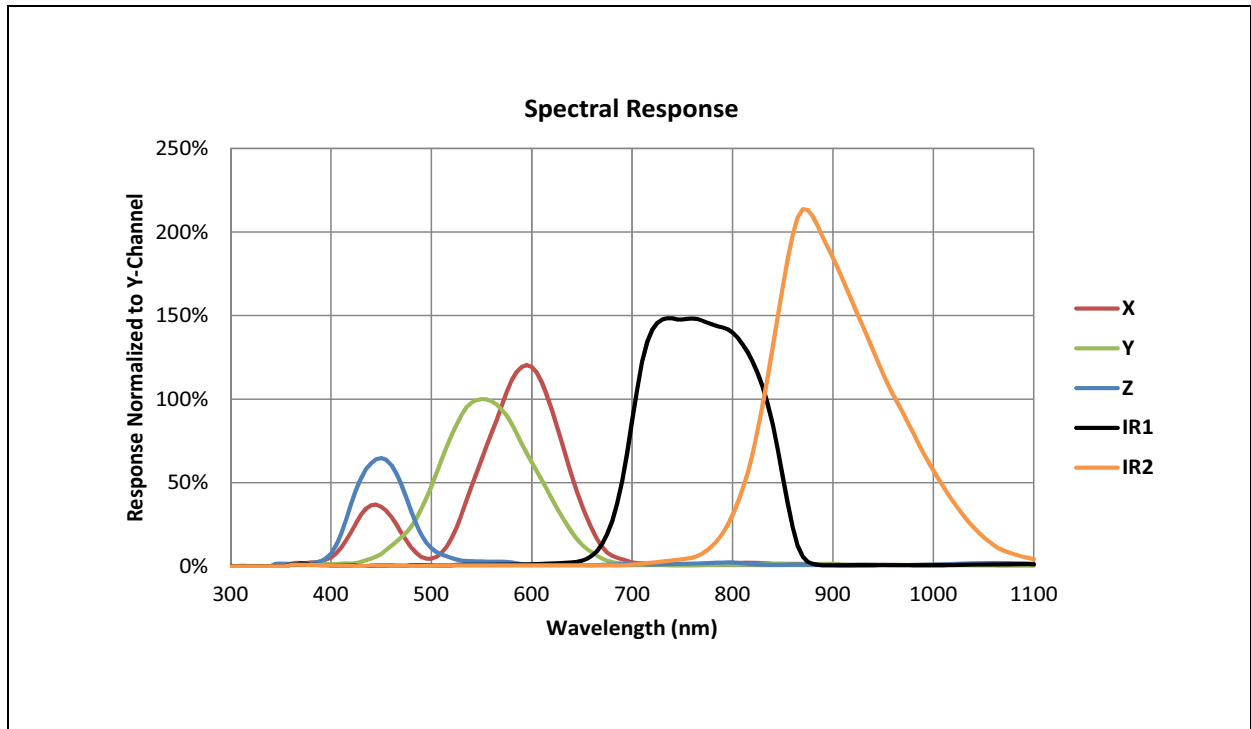

**Note(s):**

1. Response is measured with a diffuser on the surface of TCS3430 that matches the minimum recommended scattering characteristic shown in [Figure 40](#).

**Figure 12:**  
ALS Average Angular Response

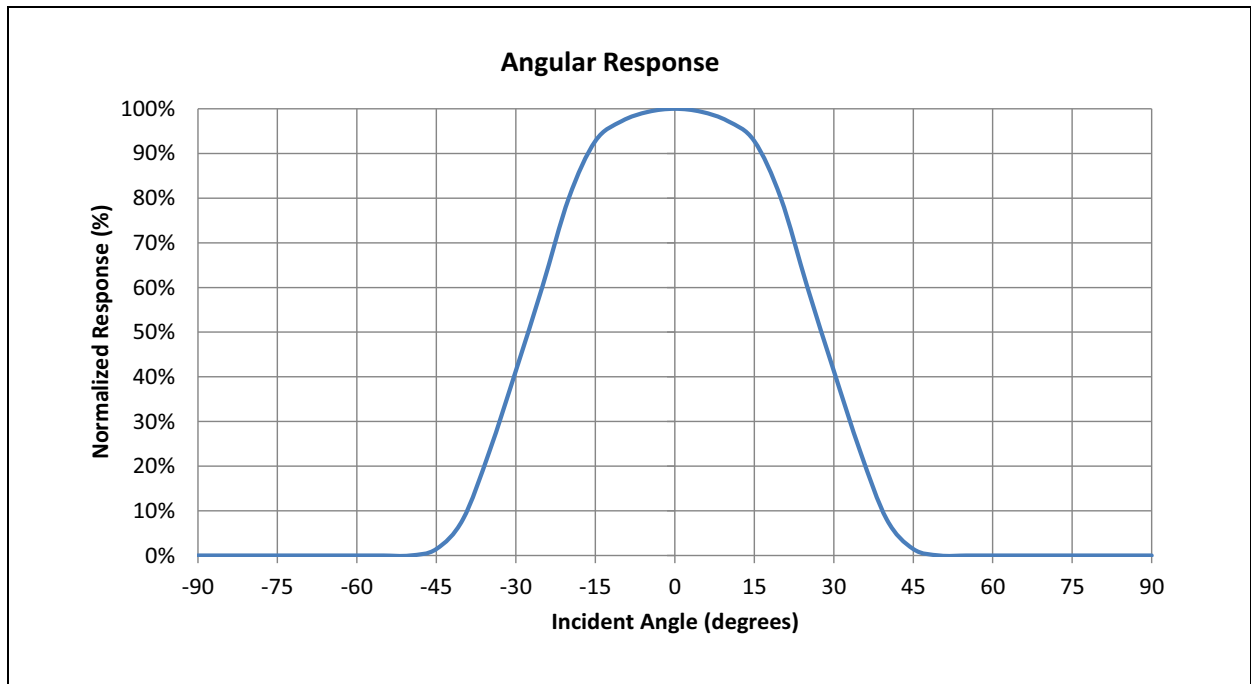

**Note(s):**

1. Response is measured without a diffuser on the surface of TCS3430 that matches the minimum recommended scattering characteristic shown in [Figure 40](#).



## I<sup>2</sup>C Protocol

The device uses I<sup>2</sup>C serial communication protocol for communication. The device supports 7-bit chip addressing and both standard and full-speed clock frequency modes. Read and Write transactions comply with the standard set by Philips (now NXP).

**Note(s):** The I<sup>2</sup>C device address can be found in [Ordering Information](#).

Internal to the device, an 8-bit buffer stores the register address location of the desired byte to read or write. This buffer auto-increments upon each byte transfer and is retained between transaction events (i.e. valid even after the master issues a STOP command and the I<sup>2</sup>C bus is released). During consecutive Read transactions, the future/repeated I<sup>2</sup>C Read transaction may omit the memory address byte normally following the chip address byte; the buffer retains the last register address + 1.

All 16-bit fields have a latching scheme for reading and writing. In general it is recommended to use I<sup>2</sup>C bursts whenever possible, especially in this case when accessing two bytes of one logical entity. When reading these fields, the low byte must be read first, and it triggers a 16-bit latch that stores the 16-bit field. The high byte must be read immediately afterwards. When writing to these fields, the low byte must be written first, immediately followed by the high byte. Reading or writing to these registers without following these requirements will cause errors.

### I<sup>2</sup>C Write Transaction

A Write transaction consists of a START, CHIP-ADDRESSWRITE, REGISTER-ADDRESS WRITE, DATA BYTE(S), and STOP. Following each byte (9TH clock pulse) the slave places an ACKNOWLEDGE/NOT- ACKNOWLEDGE (ACK/NACK) on the bus. If NACK is transmitted by the slave, the master may issue a STOP.

### I<sup>2</sup>C Read Transaction

A Read transaction consists of a START, CHIP-ADDRESSWRITE, REGISTER-ADDRESS, RESTART, CHIP-ADDRESSREAD, DATA BYTE(S), and STOP. Following all but the final byte the master places an ACK on the bus (9TH clock pulse). Termination of the Read transaction is indicated by a NACK being placed on the bus by the master, followed by STOP.

The I<sup>2</sup>C bus protocol was developed by Philips (now NXP). For a complete description of the I<sup>2</sup>C protocol, please review the NXP I<sup>2</sup>C design specification.

## Register Description

Figure 13:  
Register Overview

Address	Register Name	R/W	Register Function	Reset Value
0x80	ENABLE	R/W	Enables states and interrupts	0x00
0x81	ATIME	R/W	ADC integration time	0x00
0x83	WTIME	R/W	ALS wait time	0x00
0x84	AILTL	R/W	ALS interrupt low threshold low byte	0x00
0x85	AILTH	R/W	ALS interrupt low threshold high byte	0x00
0x86	AIHTL	R/W	ALS interrupt high threshold low byte	0x00
0x87	AIHTH	R/W	ALS interrupt high threshold high byte	0x00
0x8C	PERS	R/W	ALS interrupt persistence filters	0x00
0x8D	CFG0	R/W	Configuration register zero	0x80
0x90	CFG1	R/W	Configuration register one	0x00
0x91	REVID	R	Revision ID	0x41
0x92	ID	R	Device ID	0xDC
0x93	STATUS	R	Device status register one	0x00
0x94	CH0DATAH	R	Z CH0 ADC High Byte Register	0x00
0x95	CH0DATAH	R	Z CH0 ADC High Byte Register	0x00
0x96	CH1DATAH	R	Y Ch1 ADC High Byte Register	0x00
0x97	CH1DATAH	R	Y CH1 ADC High Byte Register	0x00
0x98	CH2DATAH	R	IR1 - CH2 ADC High Byte Register	0x00
0x99	CH2DATAH	R	IR1 - Ch2 ADC High Byte Register	0x00
0x9A	CH3DATAH	R	X or IR2 - CH3 ADC High Byte Register	0x00
0x9B	CH3DATAH	R	X or IR2 - CH3 ADC High Byte Register	0x00
0x9F	CFG2	R/W	Configuration register two	0x04
0xAB	CFG3	R/W	Configuration register three	0x00
0xD6	AZ_CONFIG	R/W	Auto zero configuration	0x7F
0xDD	INTENAB	R/W	Interrupt enables	0x00

**Note(s):**

- Register Access:  
**R** = Read Only  
**W** = Write Only  
**R/W** = Read or Write  
**SC** = Self Clearing after access

**ENABLE Register (0x80)****Figure 14:**  
**ENABLE Register**

0x80: ENABLE				
Field	Name	Reset	Type	Description
7:4	RESERVED	0	RW	Reserved
3	WEN	0	RW	Wait Enable. This bit activates the wait feature. Writing a one activates the wait timer. Writing a zero disables the wait timer.
2	RESERVED	0	RW	Reserved
1	AEN	0	RW	ALS Enable. This bit activates the ALS function. Set aen=1 and pon=1 in the same command to ensure autozero function is run prior to the first measurement.
0	PON	0	RW	Power ON. This field activates the internal oscillator to permit the timers and ADC channels to operate. Writing a one activates the oscillator. Writing a zero disables the oscillator.

The mode/parameter fields should be written before AEN is asserted. The function AEN requires PON to be asserted to operate correctly.

### ATIME Register (0x81)

Figure 15:  
ATIME Register

0x81: ATIME							
Field	Name	Reset	Type	Description			
7:0	ATIME	0x00	RW	Integration Time. Eight bit value that specifies the integration time in 2.78ms intervals. 0x00 indicates 2.78ms, 0x01 indicates 5.56ms. The maximum ALS value depends on the integration time. For every 2.78ms, the maximum value increases by 1024. This means that to be able to reach ALS full scale, the integration time has to be at least 64*2.78ms.			
				<b>Value</b>	<b>Integration Cycles</b>	<b>Integration Time</b>	<b>Maximum ALS Value</b>
				0x00	1	2.78ms	1023
				0x01	2	5.56ms	2047
				...	...	...	...
				0x11	18	50ms	18431
				0x40	65	181ms	65535
				...	...	...	...
0xff	256	711ms	65535				

The ATIME register controls the integration time of the ALS ADCs.

The timer is implemented with a down counter with 0x00 as the terminal count. The timer is clocked at a 2.78ms nominal rate. Loading 0x00 will generate a 2.78ms integration time, loading 0x01 will generate a 5.56ms integration time, and so forth.

**WTIME Register (0x83)****Figure 16:**  
WTIME Register

0x83: WTIME						
Field	Name	Reset	Type	Description		
7:0	WTIME	0x00	RW	ALS Wait Time. Eight bit value that specifies the time in 2.78ms to wait between ALS cycles.		
				<b>Value</b>	<b>Wait Cycles</b>	<b>Wait Time</b>
				0x00	1	2.78ms/ 33.4ms
				0x01	2	5.56ms/ 66.7ms
				...	...	...
				0x23	36	100ms/ 1.20s
				...	...	...
				0xff	256	711ms/ 8.53s

The wait timer is implemented with an down counter with 0x00 as the terminal count. Loading 0x00 will generate a 2.78ms wait time, loading 0x01 will generate a 5.56ms wait time, and so forth; By asserting wlong, in register 0x8D the wait time is given in multiples of 33.4ms (12x).

**AILTL Register (0x84)****Figure 17:**  
AILTL Register

0x84: AILTL				
Field	Name	Reset	Type	Description
7:0	AILTL	0x00	RW	Low Byte of the Low Threshold

This register provides the low byte of the low interrupt ALS (Channel 0) threshold.

### AILTH Register (0x85)

Figure 18:  
AILTH Register

0x85: AILTH				
Field	Name	Reset	Type	Description
7:0	AILTH	0x00	RW	High Byte of the Low Threshold

This register provides the high byte of the low interrupt ALS (Channel 0) threshold.

The contents of the AILTH and AILTL registers are combined and treated as a sixteen bit threshold. If the value generated by Channel 0 is below the low threshold specified and the APERS value is reached, the aint bit is asserted which will assert the INT pin if aien is set.

There is an 8-bit data latch implemented that stores the written low byte until the high byte is written. Both bytes will be applied then at the same time to avoid an invalid threshold (e.g. when going from 0x00ff to 0x0100, the invalid intermediate value 0x0000 is suppressed. This implies that 1) the LSB cannot be changed without writing to the MSB and 2) that writing to the LSB of one 16-bit value and afterwards to the MSB of another 16-bit register will write all 16 bits to the MSB related register.

### AIHTL Register (0x86)

**Figure 19:**  
AIHTL Register

0x86: AIHTL				
Field	Name	Reset	Type	Description
7:0	AIHTL	0	RW	Low Byte of the High Threshold

This register provides the low byte of the high interrupt threshold.

### AIHTH Register (0x87)

**Figure 20:**  
AIHTH Register

0x87: AIHTH				
Field	Name	Reset	Type	Description
7:0	AIHTH	0	RW	High Byte of the High Threshold

This register provides the low byte of the high interrupt threshold.

The contents of the AIHTH and AIHTL registers are combined and treated as a sixteen bit threshold. If the value generated by Channel 0 is above the high threshold specified and the APERS value is reached, the aint bit is asserted which will assert the INT pin if aien is set.

**PERS Register (0x8C)**

**Figure 21:**  
PERS Register

0x8C: PERS					
Field	Name	Reset	Type	Description	
7:4	RESERVED	0	RW	Reserved	
3:0	APERS	0	RW	<b>Value</b>	<b>Interrupt Generated When...</b>
				0	Every ALS cycle
				1	Any ALS value outside of threshold range
				2	2 consecutive ALS values out of range
				3	3 consecutive ALS values out of range
				4	5...
				5	10...
				6	15...
				7	20...
				12	45...
				13	50...
				14	55...
				15	60 consecutive ALS values out of range

This register controls the interrupt filtering capabilities of the device. Configurable filtering is provided to allow interrupts to be generated after either an ALS integration cycle or if the integration cycle has produced a result that is outside of the values specified by threshold register for some specified number of times.

ALS interrupts are generated by looking only at the ADC integration results of Channel 0 photodiode.



**CFG0 Register (0x8D)****Figure 22:**  
**CFG0 Register**

0x8D: CFG0				
Field	Name	Reset	Type	Description
7:3	RESERVED	1 0 0 0 0	RW	Reserved. Must be set to 10000.
2	WLONG	0	RW	Wait Long. When asserted, the wait cycle is increased by a factor 12x from that programmed in the WTIME register.
1:0	RESERVED	0 0	RW	Reserved. Must be set to 00.

**CFG1 Register (0x90)****Figure 23:**  
**CFG1 Register**

0x90: CFG1					
Field	Name	Reset	Type	Description	
7:4	RESERVED	0	RW	Reserved	
3	AMUX	0	RW	ALS Multiplexer. Sets the CH3 input. Default = 0 (X Channel). Set to 1 to read IR2.	
2	RESERVED	0	RW	Reserved	
1:0	AGAIN	0	RW	ALS Gain Control. Sets the gain of the ALS DAC.	
				<b>Field Value</b>	<b>Gain</b>
				00	1x
				01	4x
				10	16x
				11	64x

**CFG1 Register:** Register CFG1 sets the gain level for ALS measurements. The valid range of values is 0x00 - 0x03.

### REVID Register (0x91)

Figure 24:  
REVID Register

0x91: REVID				
Field	Name	Reset	Type	Description
7:3	RESERVED	01000	RO	Reserved
2:0	REV_ID	001	RO	Revision Number Identification

### ID Register (0x92)

Figure 25:  
ID Register

0x92: ID					
Field	Name	Reset	Type	Description	
7:2	ID	110111	RO	Part Number Identification	
				<b>Value</b>	<b>Meaning</b>
				110111	TCS3430
1:0	RESERVED	00	RO	Reserved	

**STATUS Register (0x93)****Figure 26:**  
**STATUS Register**

0x93: STATUS				
Field	Name	Reset	Type	Description
7	ASAT	0	R, SC	ALS Saturation. This flag is set for analog saturation writing a 1 will clear this status flag.
6:5	RESERVED	0	R, SC	Reserved
4	AINT	0	R, SC	ALS Interrupt. Indicates that the device is asserting an ALS interrupt. writing a 1 will clear this status flag.
3:0	RESERVED	0	R, SC	Reserved

**CH0DATAL Register (0x94)****Figure 27:**  
**CH0DATAL Register**

0x94: CH0DATAL				
Field	Name	Reset	Type	Description
7:0	CH0DATAL	0	RO	Low Byte of CH0 ADC data. Contains Z data.

**CH0DATAH Register (0x95)****Figure 28:**  
**CH0DATAH Register**

0x95: CH0DATAH				
Field	Name	Reset	Type	Description
7:0	CH0DATAH	0	RO	High Byte of CH0 ADC data. Contains Z data.

### CH1DATAL Register (0x96)

Figure 29:  
CH1DATAL Register

0x96: CH1DATAL				
Field	Name	Reset	Type	Description
7:0	CH1DATAL	0	RO	Low Byte of CH1 ADC data. Contains Y data.

### CH1DATAH Register (0x97)

Figure 30:  
CH1DATAH Register

0x97: CH1DATAH				
Field	Name	Reset	Type	Description
7:0	CH1DATAH	0	RO	High Byte of CH1 ADC data. Contains Y data.

### CH2DATAL Register (0x98)

Figure 31:  
CH2DATAL Register

0x98: CH2DATAL				
Field	Name	Reset	Type	Description
7:0	CH2DATAL	0	RO	Low Byte of CH2 ADC data. Contains IR1 data.

### CH2DATAH Register (0x99)

Figure 32:  
CH2DATAH Register

0x99: CH2DATAH				
Field	Name	Reset	Type	Description
7:0	CH2DATAH	0	RO	High Byte of CH2 ADC data. Contains IR1 data.

### CH3DATAL Register (0x9A)

Figure 33:  
CH3DATAL Register

0x9A: CH3DATAL				
Field	Name	Reset	Type	Description
7:0	CH3DATAL	0	RO	Low Byte of CH3 ADC data. If AMUX = 0 contains X data. If AMUX = 1 contains IR2 data.  Default = X data.

### CH3DATAH Register (0x9B)

Figure 34:  
CH3DATAH Register

0x9B: CH3DATAH				
Field	Name	Reset	Type	Description
7:0	CH3DATAH	0	RO	High Byte of CH3 ADC data. If AMUX = 0 contains X data. If AMUX = 1 contains IR2 data.  Default = X data.

### CFG2 Register (0x9F)

Figure 35:  
CFG2 Register

0x9F: CFG2				
Field	Name	Reset	Type	Description
7:5	Reserved	000	RW	Reserved. Set to 000.
4	HGAIN	0	RW	High 128x gain. If this bit is set and AGAIN in the CFG1 register is set to 11, then the 128x gain mode will be enabled.
3:0	Reserved	0100	RW	Reserved. Set to 0100.

### CFG3 Register (0xAB)

Figure 36:  
CFG3 Register

0xAB: CFG3																								
Field	Name	Reset	Type	Description																				
7	INT_READ_CLEAR	0	RW	If this bit is set, all flag bits in the STATUS register will be reset whenever the STATUS register is read over I <sup>2</sup> C.																				
6:5	RESERVED	0	RW	Reserved. Set to 0.																				
4	SAI	0	RW	Sleep After Interrupt. Power down the device at the end of the ALS cycle if an interrupt has been generated. <sup>(1)</sup>																				
				<table border="1"> <thead> <tr> <th>PON</th> <th>SAI</th> <th>INT (low active)</th> <th>Oscillator</th> </tr> </thead> <tbody> <tr> <td>0</td> <td>x</td> <td>x</td> <td>OFF</td> </tr> <tr> <td>1</td> <td>0</td> <td>x</td> <td>ON</td> </tr> <tr> <td>1</td> <td>1</td> <td>1</td> <td>ON</td> </tr> <tr> <td>1</td> <td>1</td> <td>0</td> <td>OFF (SAI induced sleep)</td> </tr> </tbody> </table>	PON	SAI	INT (low active)	Oscillator	0	x	x	OFF	1	0	x	ON	1	1	1	ON	1	1	0	OFF (SAI induced sleep)
				PON	SAI	INT (low active)	Oscillator																	
				0	x	x	OFF																	
				1	0	x	ON																	
				1	1	1	ON																	
1	1	0	OFF (SAI induced sleep)																					
The way to “wake up” the device from SAI-sleep is by clearing the interrupt register 0x93.																								
3:0	RESERVED	0	RW	Reserved. Set to 0.																				

**Note(s):**

1. SAI does not modify any register bits directly, it rather uses the interrupt signal to turn OFF the oscillator.

**AZ\_CONFIG Register (0xD6)****Figure 37:**  
**AZ\_CONFIG Register**

0xD6: AZ_CONFIG				
Field	Name	Reset	Type	Description
7	AZ_MODE	0	RW	0: Always start at zero when searching the best offset value 1: Always start at the previous (offset_c) with the auto-zero mechanism <sup>(1)</sup>
6:0	AZ_NTH_ITERATION	0x7F	RW	Run autozero automatically every nth ALS iteration (0=never, 7Fh=only at first ALS cycle, n=every nth time)

**Note(s):**

1. On average mode 1 is faster, but in the worst case, mode 0 is faster.

**INTENAB Register (0xDD)****Figure 38:**  
**INTENAB Register**

0xDD: INTENAB				
Field	Name	Reset	Type	Description
7	ASIEN	0	RW	Writing '1' to this bit enables ASAT interrupt.
6:5	RESERVED	0	RW	Reserved
4	AIEN	0	RW	Writing '1' to this bit enables ALS interrupt.
3:0	RESERVED	0	RW	Reserved

## Application Information

**Figure 39:**  
Typical Application Hardware Circuit

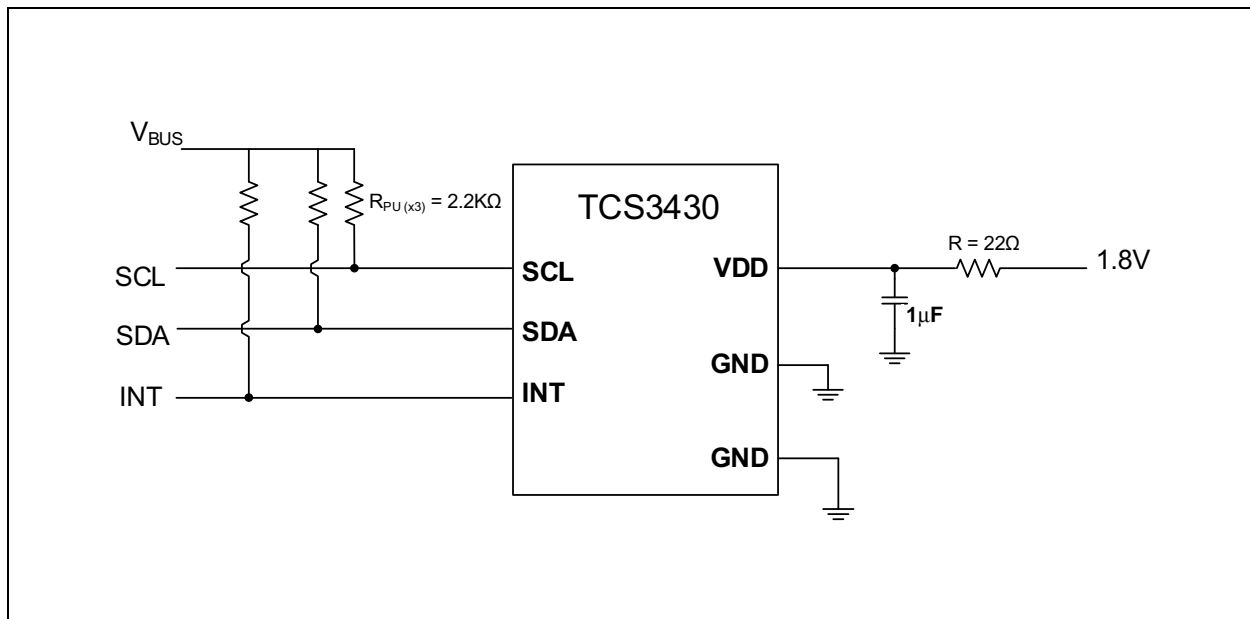

**Note(s):**

1. Place the 1μF capacitors as close as possible to the module.
2. V<sub>DD</sub> = 1.8V, V<sub>BUS</sub> = 1.8V.
3. The N/C pins (5 and 6) that are not indicated in the circuit diagram may be connected to GND or not connected (remain open).



### Application Optical Requirements

For optimal performance an achromatic diffuser shall be placed above the device aperture. The recommended solution is a bulk diffuser that meets the minimum recommended scattering characteristic shown below. For more details refer to the Optical Design Guide or contact **ams**.

Figure 40:  
Diffuser Characteristics

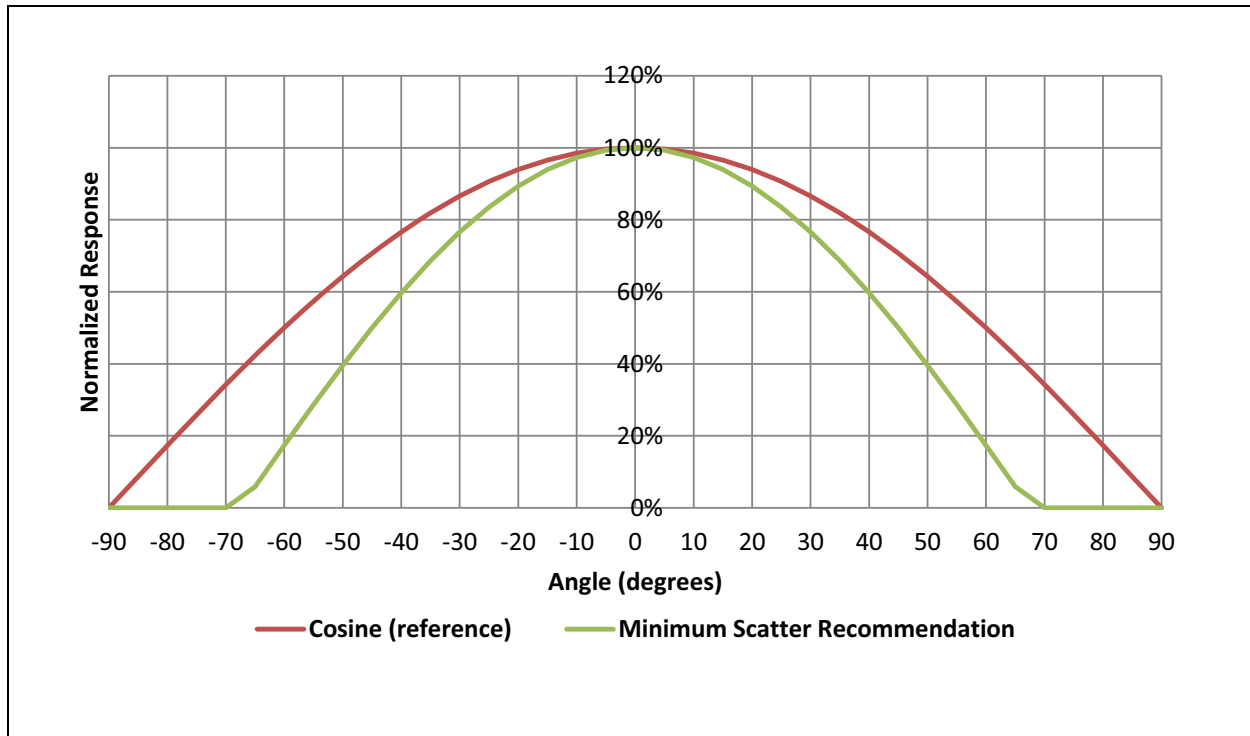

## PCB Pad Layout

Figure 41:  
Recommended PCB Pad Layout

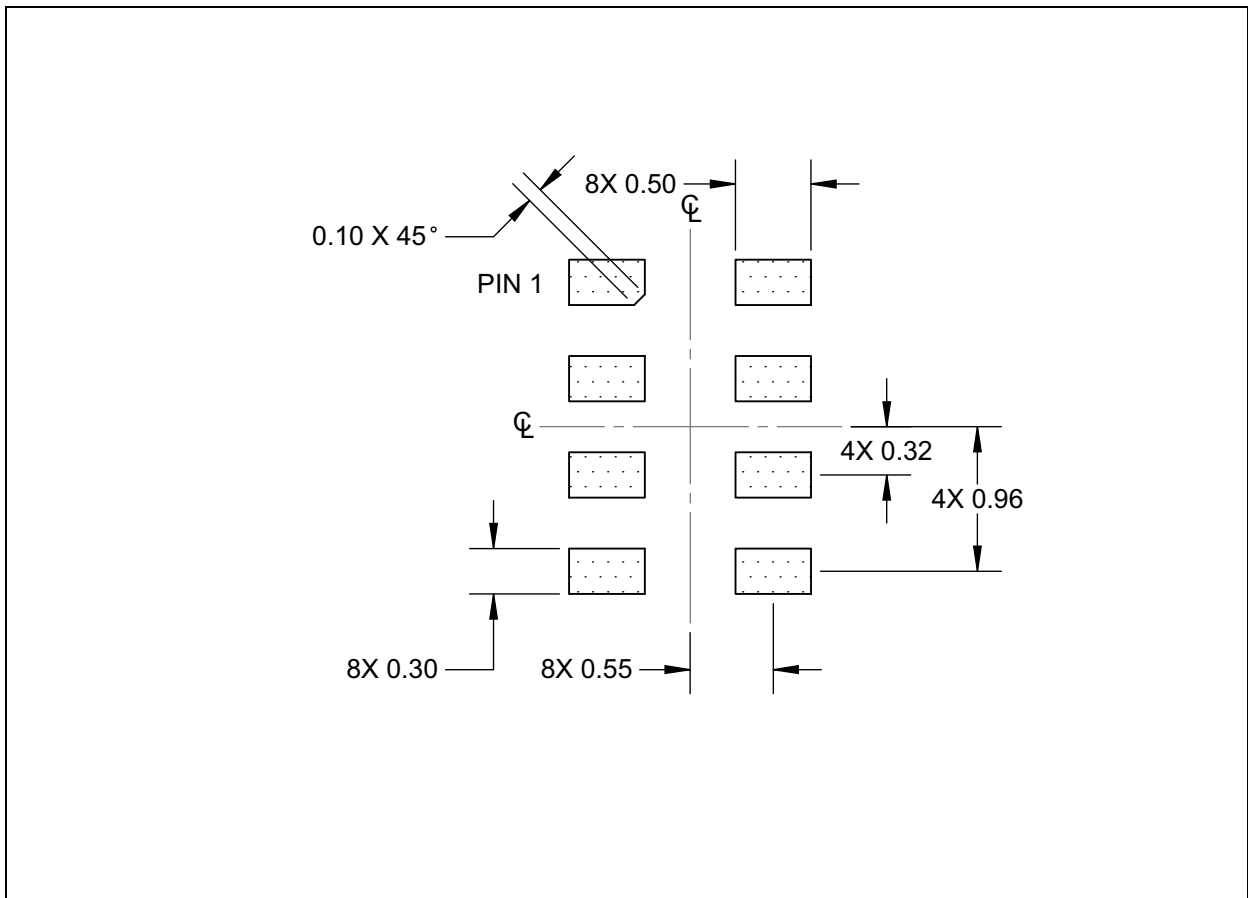

**Note(s):**

1. All linear dimensions are in millimeters.
2. Dimension tolerances are 0.05mm unless otherwise noted.
3. This drawing is subject to change without notice.
4. Layout as shown when viewed from above.

## Packaging Mechanical Data

Figure 42:  
Package Drawing

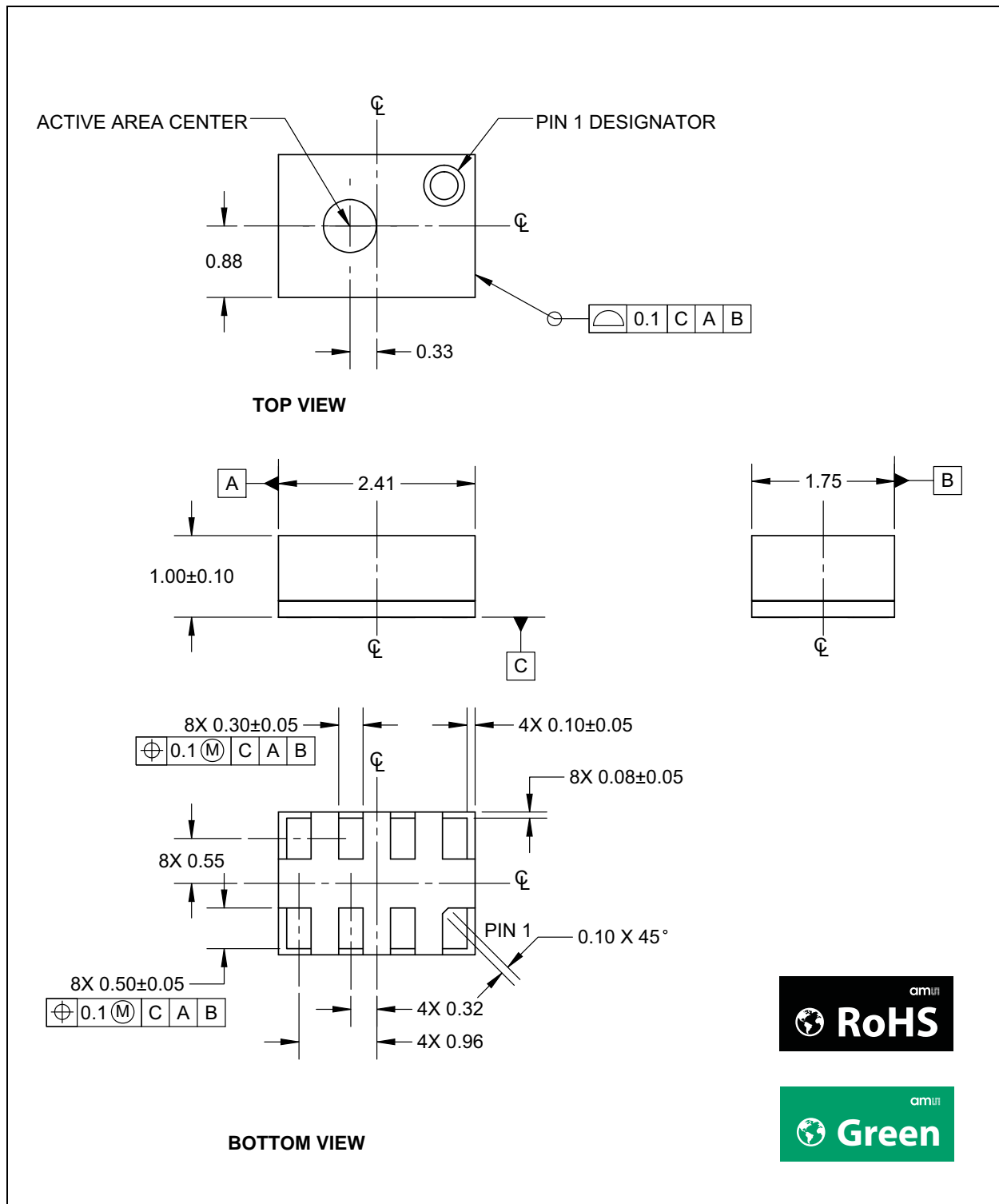

**Note(s):**

1. All linear dimensions are in millimeters.
2. Contact finish is Au.
3. This package contains no lead (Pb).
4. This drawing is subject to change without notice.

### Tape & Reel Information

Figure 43:  
Tape & Reel Information

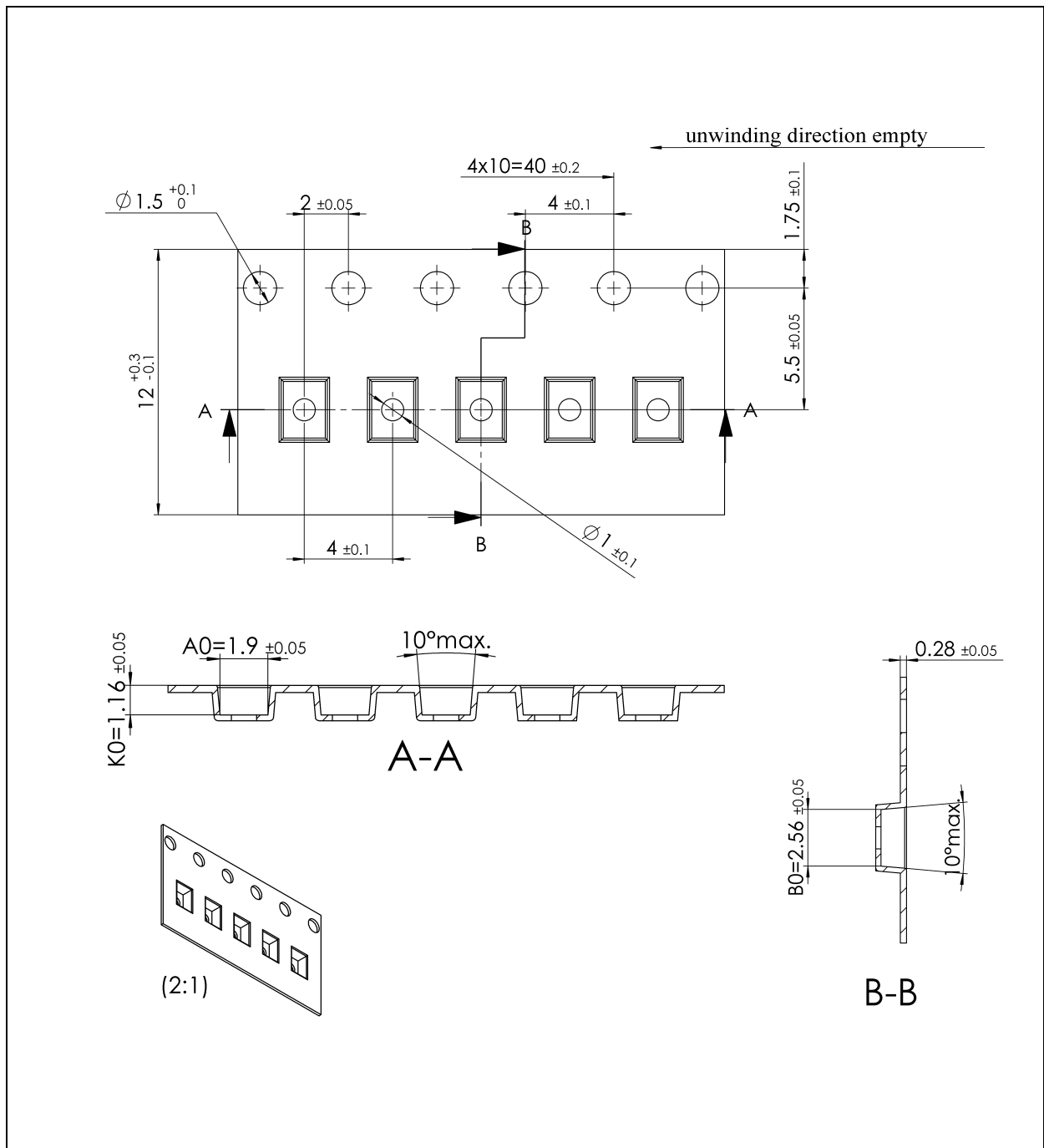

**Note(s):**

1. All linear dimensions are in millimeters.
2. For missing tolerances and dimensions, refer to EIA-481.

## Soldering & Storage Information

The module has been tested and has demonstrated an ability to be reflow soldered to a PCB substrate.

The solder reflow profile describes the expected maximum heat exposure of components during the solder reflow process of product on a PCB. Temperature is measured on top of component. The components should be limited to a maximum of three passes through this solder reflow profile.

**Figure 44:**  
**Solder Reflow Profile**

Parameter	Reference	Device
Average temperature gradient in preheating		2.5°C/s
Soak time	$t_{soak}$	2 to 3 minutes
Time above 217°C ( $T_1$ )	$t_1$	Max 60s
Time above 230°C ( $T_2$ )	$t_2$	Max 50s
Time above $T_{peak} - 10\text{ °C}$ ( $T_3$ )	$t_3$	Max 10s
Peak temperature in reflow	$T_{peak}$	260°C
Temperature gradient in cooling		Max -5°C/s

**Figure 45:**  
**Solder Reflow Profile Graph**

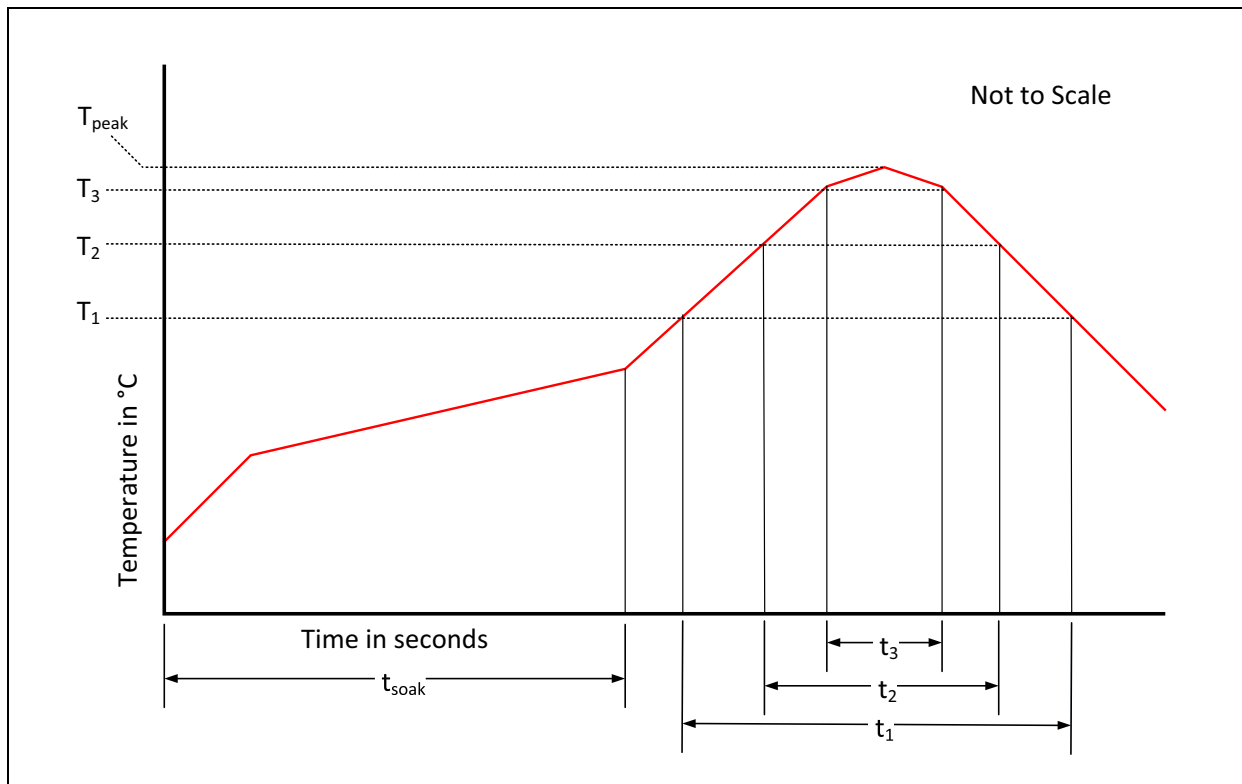

## Storage Information

### **Moisture Sensitivity**

Optical characteristics of the device can be adversely affected during the soldering process by the release and vaporization of moisture that has been previously absorbed into the package. To ensure the package contains the smallest amount of absorbed moisture possible, each device is baked prior to being dry packed for shipping.

Devices are dry packed in a sealed aluminized envelope called a moisture-barrier bag with silica gel to protect them from ambient moisture during shipping, handling, and storage before use.

### **Shelf Life**

The calculated shelf life of the device in an unopened moisture barrier bag is 12 months from the date code on the bag when stored under the following conditions:

- Shelf Life: 12 months
- Ambient Temperature: <40°C
- Relative Humidity: <90%

Rebaking of the devices will be required if the devices exceed the 12 month shelf life or the Humidity Indicator Card shows that the devices were exposed to conditions beyond the allowable moisture region.

### **Floor Life**

The module has been assigned a moisture sensitivity level of MSL 3. As a result, the floor life of devices removed from the moisture barrier bag is 168 hours from the time the bag was opened, provided that the devices are stored under the following conditions:

- Floor Life: 168 hours
- Ambient Temperature: <30°C
- Relative Humidity: <60%

If the floor life or the temperature/humidity conditions have been exceeded, the devices must be rebaked prior to solder reflow or dry packing.

### **Rebaking Instructions**

When the shelf life or floor life limits have been exceeded, rebake at 50°C for 12 hours.

## Ordering & Contact Information

Figure 46:  
Ordering Information

Ordering Code	I <sup>2</sup> C Bus	I <sup>2</sup> C Addr	Delivery Form	Delivery Quantity
TCS34303	1.8V	0x39	Tape & Reel (13")	10000 pcs/reel

Buy our products or get free samples online at:

[www.ams.com/ICdirect](http://www.ams.com/ICdirect)

Technical Support is available at:

[www.ams.com/Technical-Support](http://www.ams.com/Technical-Support)

Provide feedback about this document at:

[www.ams.com/Document-Feedback](http://www.ams.com/Document-Feedback)

For further information and requests, e-mail us at:

[ams\\_sales@ams.com](mailto:ams_sales@ams.com)

For sales offices, distributors and representatives, please visit:

[www.ams.com/contact](http://www.ams.com/contact)

### Headquarters

ams AG

Tobelbader Strasse 30

8141 Premstaetten

Austria, Europe

Tel: +43 (0) 3136 500 0

Website: [www.ams.com](http://www.ams.com)

## RoHS Compliant & ams Green Statement

**RoHS:** The term RoHS compliant means that ams AG products fully comply with current RoHS directives. Our semiconductor products do not contain any chemicals for all 6 substance categories, including the requirement that lead not exceed 0.1% by weight in homogeneous materials. Where designed to be soldered at high temperatures, RoHS compliant products are suitable for use in specified lead-free processes.

**ams Green (RoHS compliant and no Sb/Br):** ams Green defines that in addition to RoHS compliance, our products are free of Bromine (Br) and Antimony (Sb) based flame retardants (Br or Sb do not exceed 0.1% by weight in homogeneous material).

**Important Information:** The information provided in this statement represents ams AG knowledge and belief as of the date that it is provided. ams AG bases its knowledge and belief on information provided by third parties, and makes no representation or warranty as to the accuracy of such information. Efforts are underway to better integrate information from third parties. ams AG has taken and continues to take reasonable steps to provide representative and accurate information but may not have conducted destructive testing or chemical analysis on incoming materials and chemicals. ams AG and ams AG suppliers consider certain information to be proprietary, and thus CAS numbers and other limited information may not be available for release.



## Copyrights & Disclaimer

Copyright ams AG, Tobelbader Strasse 30, 8141 Premstaetten, Austria-Europe. Trademarks Registered. All rights reserved. The material herein may not be reproduced, adapted, merged, translated, stored, or used without the prior written consent of the copyright owner.

Devices sold by ams AG are covered by the warranty and patent indemnification provisions appearing in its General Terms of Trade. ams AG makes no warranty, express, statutory, implied, or by description regarding the information set forth herein. ams AG reserves the right to change specifications and prices at any time and without notice. Therefore, prior to designing this product into a system, it is necessary to check with ams AG for current information. This product is intended for use in commercial applications. Applications requiring extended temperature range, unusual environmental requirements, or high reliability applications, such as military, medical life-support or life-sustaining equipment are specifically not recommended without additional processing by ams AG for each application. This product is provided by ams AG "AS IS" and any express or implied warranties, including, but not limited to the implied warranties of merchantability and fitness for a particular purpose are disclaimed.

ams AG shall not be liable to recipient or any third party for any damages, including but not limited to personal injury, property damage, loss of profits, loss of use, interruption of business or indirect, special, incidental or consequential damages, of any kind, in connection with or arising out of the furnishing, performance or use of the technical data herein. No obligation or liability to recipient or any third party shall arise or flow out of ams AG rendering of technical or other services.

## Document Status

Document Status	Product Status	Definition
Product Preview	Pre-Development	Information in this datasheet is based on product ideas in the planning phase of development. All specifications are design goals without any warranty and are subject to change without notice
Preliminary Datasheet	Pre-Production	Information in this datasheet is based on products in the design, validation or qualification phase of development. The performance and parameters shown in this document are preliminary without any warranty and are subject to change without notice
Datasheet	Production	Information in this datasheet is based on products in ramp-up to full production or full production which conform to specifications in accordance with the terms of ams AG standard warranty as given in the General Terms of Trade
Datasheet (discontinued)	Discontinued	Information in this datasheet is based on products which conform to specifications in accordance with the terms of ams AG standard warranty as given in the General Terms of Trade, but these products have been superseded and should not be used for new designs

## Revision Information

Changes from 1-06 (2017-Mar-31) to current revision 1-10 (2018-Mar-08)	Page
<b>1-06 (2017-Mar-31) to 1-07 (2018-Jan-18)</b>	
Updated Figure 8	6
Updated Figure 13	7
Updated Figure 17	11
<b>1-07 (2018-Jan-18) to 1-08 (2018-Feb-26)</b>	
Replaced various Optical Characteristics figures with new Figure 8	6
Added Figure 9	6
<b>1-08 (2018-Feb-26) to 1-09 (2018-Mar-05)</b>	
Updated Figure 8	6
Updated Figure 9	6
<b>1-09 (2018-Mar-05) to 1-10(2018-Mar-08)</b>	
Updated Figure 9	6

**Note(s):**

1. Page and figure numbers for the previous version may differ from page and figure numbers in the current revision.
2. Correction of typographical errors is not explicitly mentioned.

## Content Guide

- 1 General Description**
  - 1 Key Benefits & Features
  - 1 Applications
  - 2 Block Diagram
- 3 Pin Assignment**
- 4 Absolute Maximum Ratings**
- 5 Electrical Characteristics**
- 10 I<sup>2</sup>C Protocol**
  - 10 I<sup>2</sup>C Write Transaction
  - 10 I<sup>2</sup>C Read Transaction
- 11 Register Description**
  - 12 ENABLE Register (0x80)
  - 13 ATIME Register (0x81)
  - 14 WTIME Register (0x83)
  - 14 AILTL Register (0x84)
  - 15 ALTH Register (0x85)
  - 16 AIHTL Register (0x86)
  - 16 AIHTH Register (0x87)
  - 17 PERS Register (0x8C)
  - 18 CFG0 Register (0x8D)
  - 18 CFG1 Register (0x90)
  - 19 REVID Register (0x91)
  - 19 ID Register (0x92)
  - 20 STATUS Register (0x93)
  - 20 CH0DATAL Register (0x94)
  - 20 CH0DATAH Register (0x95)
  - 21 CH1DATAL Register (0x96)
  - 21 CH1DATAH Register (0x97)
  - 21 CH2DATAL Register (0x98)
  - 21 CH2DATAH Register (0x99)
  - 22 CH3DATAL Register (0x9A)
  - 22 CH3DATAH Register (0x9B)
  - 22 CFG2 Register (0x9F)
  - 23 CFG3 Register (0xAB)
  - 24 AZ\_CONFIG Register (0xD6)
  - 24 INTENAB Register (0xDD)
- 25 Application Information**
  - 26 Application Optical Requirements
- 27 PCB Pad Layout**
- 28 Packaging Mechanical Data**
- 29 Tape & Reel Information**
- 30 Soldering & Storage Information**
  - 31 Storage Information
  - 31 Moisture Sensitivity
  - 31 Shelf Life
  - 31 Floor Life
  - 31 Rebaking Instructions

- 32 Ordering & Contact Information**
- 33 RoHS Compliant & ams Green Statement**
- 34 Copyrights & Disclaimer**
- 35 Document Status**
- 36 Revision Information**

## Данный компонент на территории Российской Федерации

### Вы можете приобрести в компании MosChip.

Для оперативного оформления запроса Вам необходимо перейти по данной ссылке:

<http://moschip.ru/get-element>

Вы можете разместить у нас заказ для любого Вашего проекта, будь то серийное производство или разработка единичного прибора.

В нашем ассортименте представлены ведущие мировые производители активных и пассивных электронных компонентов.

Нашей специализацией является поставка электронной компонентной базы двойного назначения, продукции таких производителей как XILINX, Intel (ex.ALTERA), Vicor, Microchip, Texas Instruments, Analog Devices, Mini-Circuits, Amphenol, Glenair.

Сотрудничество с глобальными дистрибьюторами электронных компонентов, предоставляет возможность заказывать и получать с международных складов практически любой перечень компонентов в оптимальные для Вас сроки.

На всех этапах разработки и производства наши партнеры могут получить квалифицированную поддержку опытных инженеров.

Система менеджмента качества компании отвечает требованиям в соответствии с ГОСТ Р ИСО 9001, ГОСТ РВ 0015-002 и ЭС РД 009

### Офис по работе с юридическими лицами:

105318, г.Москва, ул.Щербаковская д.3, офис 1107, 1118, ДЦ «Щербаковский»

Телефон: +7 495 668-12-70 (многоканальный)

Факс: +7 495 668-12-70 (доб.304)

E-mail: [info@moschip.ru](mailto:info@moschip.ru)

Skype отдела продаж:

moschip.ru

moschip.ru\_4

moschip.ru\_6

moschip.ru\_9