

### Features

#### ●Two types circuits

60 circuit and 36 circuit types are available, and the specifications matched to the automobile are selectable.

#### ●Incomplete mating detection mechanism

Mis-insertion and insertion error at the assembly line can detect with a CPA terminal.

#### ●Terminal construction

It is designed to prevent the deformation of the contact area when processing wire harness by protecting the contact area of each terminal with a box.

#### ●Press-fit

There are dip type and press-fit type in the male connector.

The miniaturization is realized as air-bag ECU I/O connector for automobile.

This product has various circuit development and several adoption results proven, hence it enables to select the type to meet the automobile.

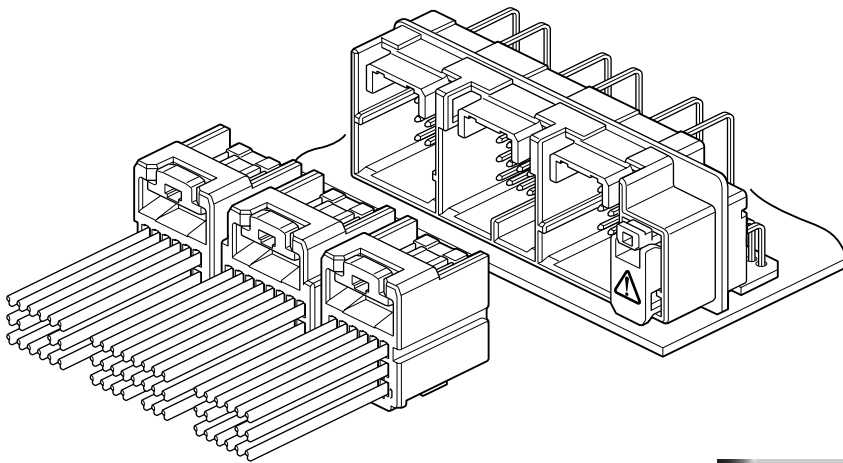

### Specifications

- Current rating: 5A AC, DC (0.5mm<sup>2</sup>, Single circuit)
- Voltage rating: 50V AC, DC
- Temperature range: -40°C to +105°C  
(including temperature rise in applying electrical current)
- Contact resistance: Initial value/8mΩ max.  
After environmental testing/16mΩ max.
- Insulation resistance: 100MΩ min.
- Withstanding voltage: 100V DC/minute
- Applicable wire: AVSS/CAVS  
0.64 Terminal S; 0.3mm<sup>2</sup> to 0.5mm<sup>2</sup>  
CHFUS  
0.64 Terminal SSS/SS; 0.13mm<sup>2</sup> to 0.35mm<sup>2</sup>

\* Compliant with ELV/RoHS.

\* Contact JST for details.

## Female terminal

### • 0.64 Female terminal SSS/SS

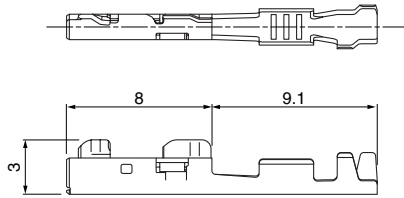

### • 0.64 Female terminal S

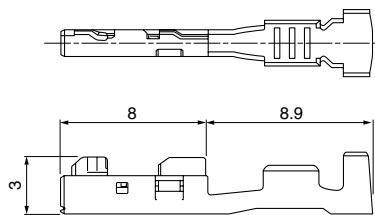

Terminal	Model No.	Applicable wire range		Q'ty/reel
		Conductor (mm <sup>2</sup> )	Insulation O.D. (mm)	
0.64 SSS	① SNAC3-A001T-M0.64	0.13	0.85	6,000
0.64 SS	① SNAC3-A011T-M0.64	0.22 to 0.35	0.95 to 1.10	5,000
0.64 S	① SNAC3-A021T-M0.64	0.3 to 0.5	1.4 to 1.8	5,000
	② SNAC3-A021GI-M0.64-1			
	③ SNAC3-A021GF-M0.64-1			

#### Material and Finish

- ① Copper alloy, tin-plated (reflow treatment)
- ② Copper alloy, nickel-undercoated,  
Male contact area; tin-plated (reflow treatment)  
Short terminal contact area; gold-plated
- ③ Copper alloy, nickel-undercoated,  
Male contact area; gold-plated  
Short terminal contact area; gold-plated

## Female connector

### • 8 circuits

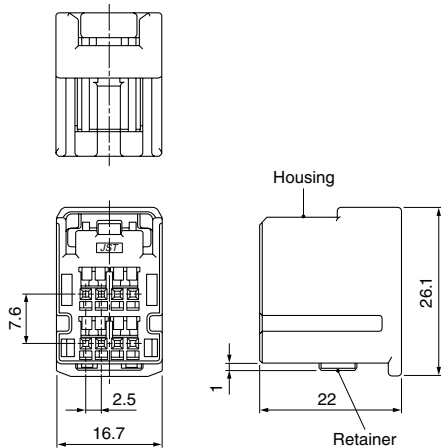

### • 16 circuits

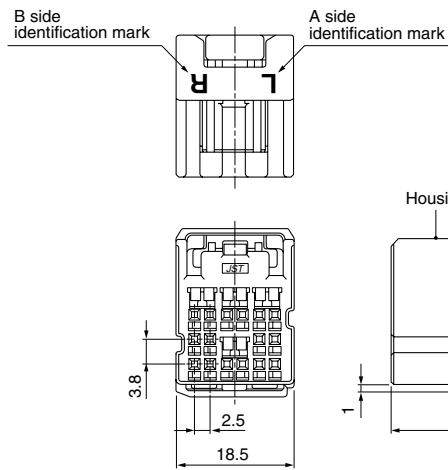

Model No.	
16CIT-B-1A	16CIT-B-2A
A figure	B figure

### • 23 circuits

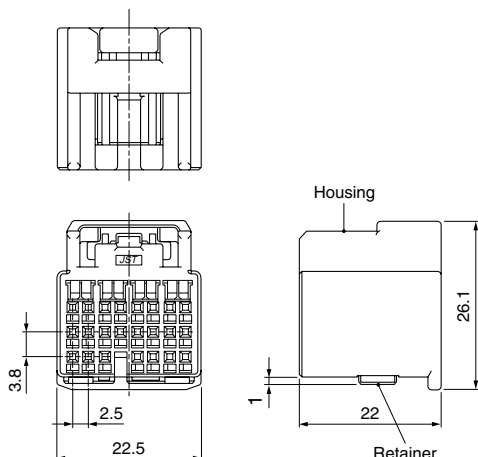

Circuits	Model No.	Q'ty/box
8	08CIT-B-1A	84
16	16CIT-B-1A	72
	16CIT-B-2A	72
23	23CIT-B-1A	60

#### Material and Finish

- Housing: PBT, yellow
- Lock housing: Glass-filled PBT, yellow
- Short terminal: Copper alloy, nickel-undercoated,  
Contact area; gold-plated
- CPA terminal: Copper alloy, nickel-undercoated,  
Contact area; gold-plated
- Retainer: PBT, natural (white)

## Male connector

### Dip type

#### ● 36 circuits

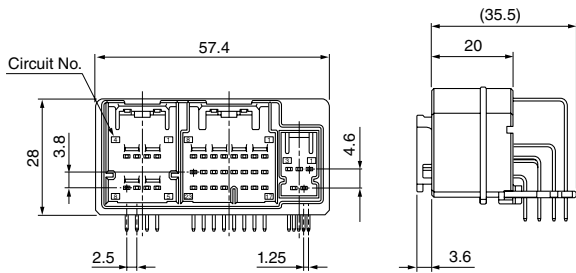

#### ● 60 circuits

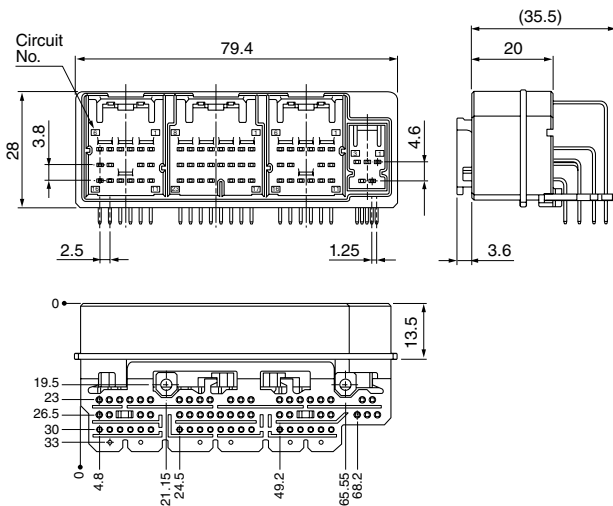

### Press-fit type

#### ● 60 circuits

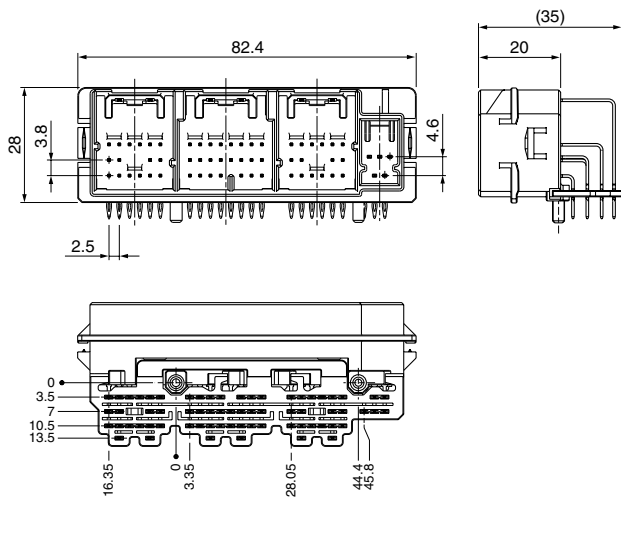

### Dip type

Circuits	Model No.	Q'ty/box
36	<b>S36B-CITYTP-01B</b>	126
60	<b>S60B-CITYTP-01B</b>	98

#### Material and Finish

0.64 pin: Brass, nickel-undercoated, tin-plated (reflow treatment)  
 1.0 pin: Brass, nickel-undercoated, tin-plated (reflow treatment)  
 CPA pin: Brass, nickel-undercoated, Contact area; gold-plated  
 Solder tail; tin-plated (reflow treatment)

Housing: Glass-filled PBT, yellow  
 Tine-plate: Glass-filled PBT, natural (white)  
 Protect cap: PBT, yellow

### Press-fit type

Circuits	Model No.	Q'ty/box
60	<b>S60B-CITYTP-P-04B</b>	60

#### Material and Finish

0.64 pin(S, M): Phosphor bronze, nickel-undercoated, tin-plated (reflow treatment)  
 0.64 pin(L): Phosphor bronze, nickel-undercoated, Contact area; gold-plated  
 Press-fit area; tin-plated (reflow treatment)  
 1.0 pin(S, M): Phosphor bronze, nickel-undercoated, tin-plated (reflow treatment)  
 CPA pin: Phosphor bronze, nickel-undercoated, Contact area; gold-plated  
 Press-fit area; tin-plated (reflow treatment)

Housing: Glass-filled PBT, yellow  
 Tine-plate: Glass-filled PBT, natural (white)  
 Protect cap: PBT, yellow

## PC board layout, Assembly layout

### Dip type

● 36 circuits

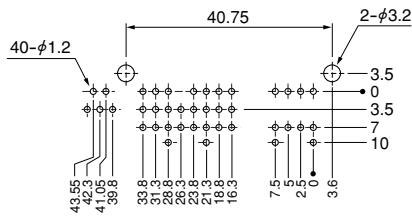

● 60 circuits

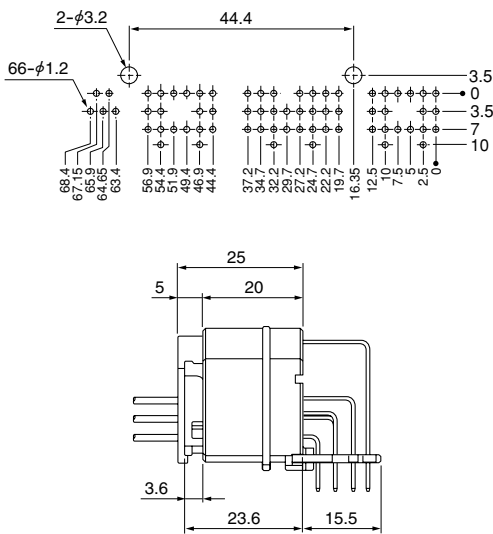

### Press-fit type

● 60 circuits

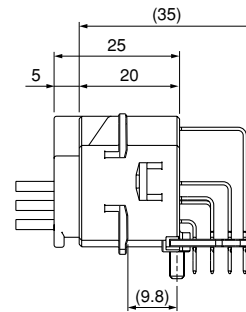
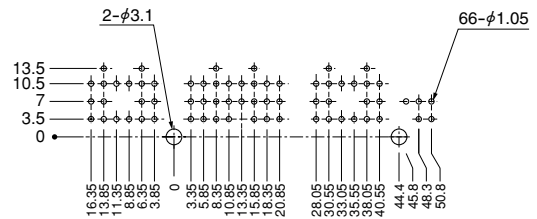

Note: 1. Tolerances are non-cumulative:  $\pm 0.05\text{mm}$  for all centers.  
 2. Hole dimensions differ according to the type of PC board and piercing method.  
 The dimensions above should serve as guideline. Contact JST for details.

## Crimping machine, Applicator, Hand crimp tool

Strip terminal	Crimping machine	Crimp applicator MKS-L		Hand crimp tool	Applicable wire
		Dies	Crimp applicator with dies		
SNAC3-A001T-M0.64	AP-K2N	MK/SNAC3-A001-064	APLMK SNAC3-A001-064	—	—
SNAC3-A011T-M0.64		MK/SNAC3-A011-064	APLMK SNAC3-A011-064	—	—
SNAC3-A021T-M0.64		MK/SNAC3-A021-064	APLMK SNAC3-A021-064	YRK-1003	AVSS0.5, CAVS0.5
SNAC3-A021GI-M0.64-1				—	—
SNAC3-A021GF-M0.64-1				—	—

Note: When crimping operation is conducted using an applicator and die set other than the above, JST cannot guarantee the performance of the terminal.

# Mouser Electronics

Authorized Distributor

Click to View Pricing, Inventory, Delivery & Lifecycle Information:

JST:

[23CIT-B-1A](#) [08CIT-B-1A](#) [16CIT-B-1A](#) [16CIT-B-2A](#) [S36B-CITYTP-01B \(M\)\(D1\)](#) [S60B-CITYTP-01B \(M\)\(D1\)](#)

## Данный компонент на территории Российской Федерации

### Вы можете приобрести в компании MosChip.

Для оперативного оформления запроса Вам необходимо перейти по данной ссылке:

<http://moschip.ru/get-element>

Вы можете разместить у нас заказ для любого Вашего проекта, будь то серийное производство или разработка единичного прибора.

В нашем ассортименте представлены ведущие мировые производители активных и пассивных электронных компонентов.

Нашей специализацией является поставка электронной компонентной базы двойного назначения, продукции таких производителей как XILINX, Intel (ex.ALTERA), Vicor, Microchip, Texas Instruments, Analog Devices, Mini-Circuits, Amphenol, Glenair.

Сотрудничество с глобальными дистрибьюторами электронных компонентов, предоставляет возможность заказывать и получать с международных складов практически любой перечень компонентов в оптимальные для Вас сроки.

На всех этапах разработки и производства наши партнеры могут получить квалифицированную поддержку опытных инженеров.

Система менеджмента качества компании отвечает требованиям в соответствии с ГОСТ Р ИСО 9001, ГОСТ РВ 0015-002 и ЭС РД 009

### Офис по работе с юридическими лицами:

105318, г.Москва, ул.Щербаковская д.3, офис 1107, 1118, ДЦ «Щербаковский»

Телефон: +7 495 668-12-70 (многоканальный)

Факс: +7 495 668-12-70 (доб.304)

E-mail: [info@moschip.ru](mailto:info@moschip.ru)

Skype отдела продаж:

moschip.ru

moschip.ru\_4

moschip.ru\_6

moschip.ru\_9