

Jul.1.2019 Copyright 2019 HIROSE ELECTRIC CO., LTD. All Rights Reserved.  
 In case of consideration for using Automotive equipment / device which demand high reliability, kindly contact our sales window correspondents.

UNIT A

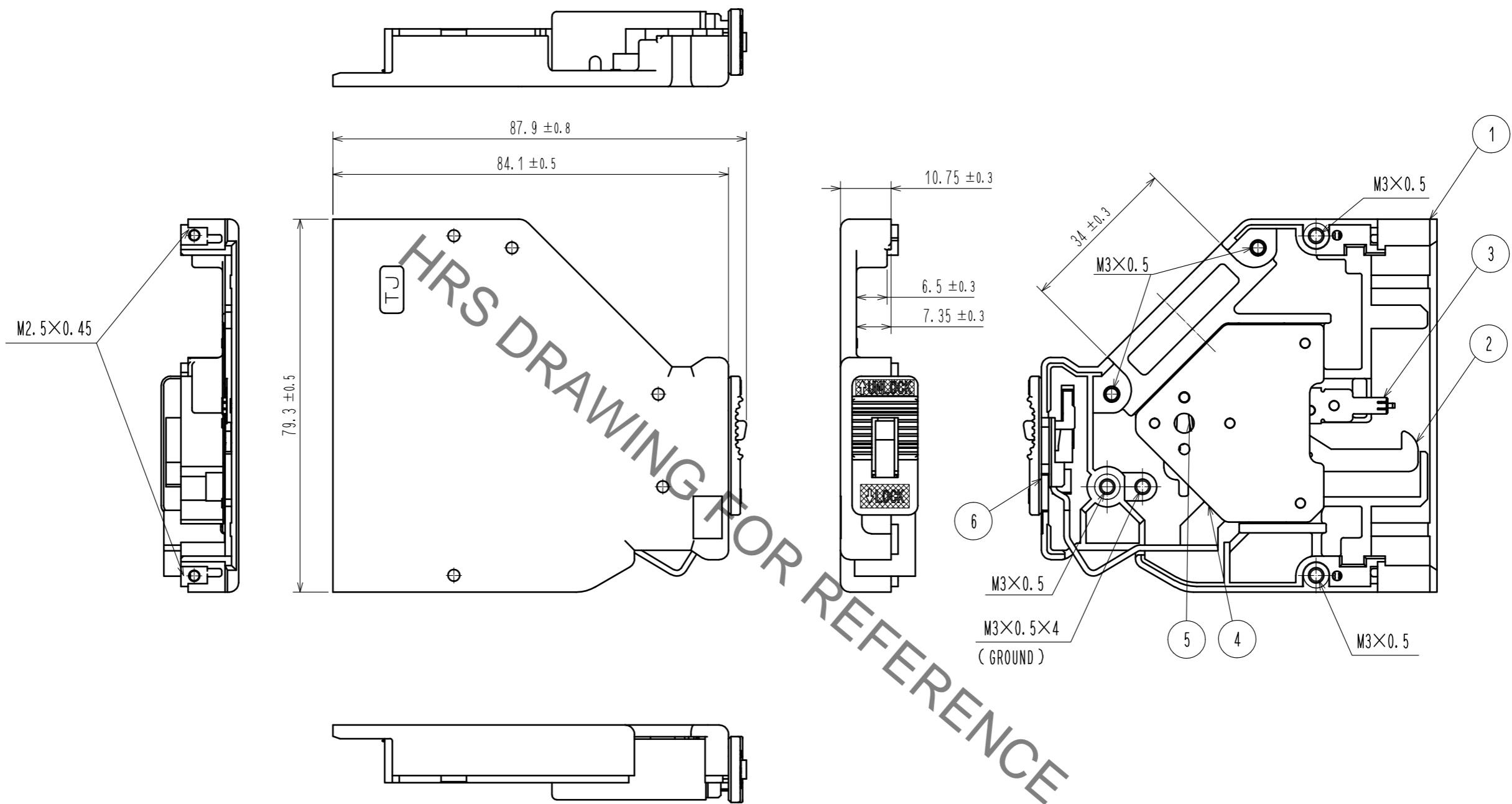

- NOTE 1. THE RECOMMENDED TIGHTENING TORQUE OF CAVER AND GROUND TO BE  $0.315 \pm 0.06 \text{ N} \cdot \text{m}$ .  
 THE RECOMMENDED TIGHTENING TORQUE OF CLAMP TO BE  $0.63 \pm 0.12 \text{ N} \cdot \text{m}$ .  
 2. THE RECOMMENDED TIGHTENING TORQUE OF CODING KEY TO BE  $0.18 \pm 0.03 \text{ N} \cdot \text{m}$ .  
 3. UNIT A TO BE ASSEMBLED TO FEMALE HOUSING U FOR FIG. 1  
 4. CODING KEY, AVAILABLE SEPARATELY, SHALL BE ATTACHED TO THIS PRODUCT AFTER ASSEMBLY.

6	PBT	BLACK, UL94V-0	12	STEEL	NICKEL PLATING M3×0.5
5	STAINLESS STEEL		11	STEEL	NICKEL PLATING
4	STAINLESS STEEL		10	PBT	BLACK, UL94V-0
3	PHOSPHOR BRONZE	NICKEL PLATING	9	STEEL	NICKEL PLATING M3×0.5
2	STAINLESS STEEL		8	STAINLESS STEEL	
1	ALUMINUM ALLOY	UNDER NICKEL PLATING + CHROME PLATING	7	ALUMINUM ALLOY	UNDER NICKEL PLATING + CHROME PLATING
NO.	MATERIAL	FINISH, REMARKS	NO.	MATERIAL	FINISH, REMARKS
UNITS		SCALE	COUNT	DESCRIPTION OF REVISIONS	
mm		1 : 1	△	DESIGNED	CHECKED
HRS		HIROSE ELECTRIC CO., LTD.	APPROVED : NM. NISHIMATSU	15.04.28	DRAWING NO. EDC-128603-00-00
			CHECKED : NM. NISHIMATSU	15.04.28	PART NO. TJ50A-41S-U-CV1
			DESIGNED : MO. SHIMOYAMA	15.04.28	CODE NO. CL236-3119-6-00
			DRAWN : MO. SHIMOYAMA	15.04.28	1/4

Jul.1.2019 Copyright 2019 HIROSE ELECTRIC CO., LTD. All Rights Reserved.  
In case of consideration for using Automotive equipment / device which demand high reliability, kindly contact our sales window correspondents.

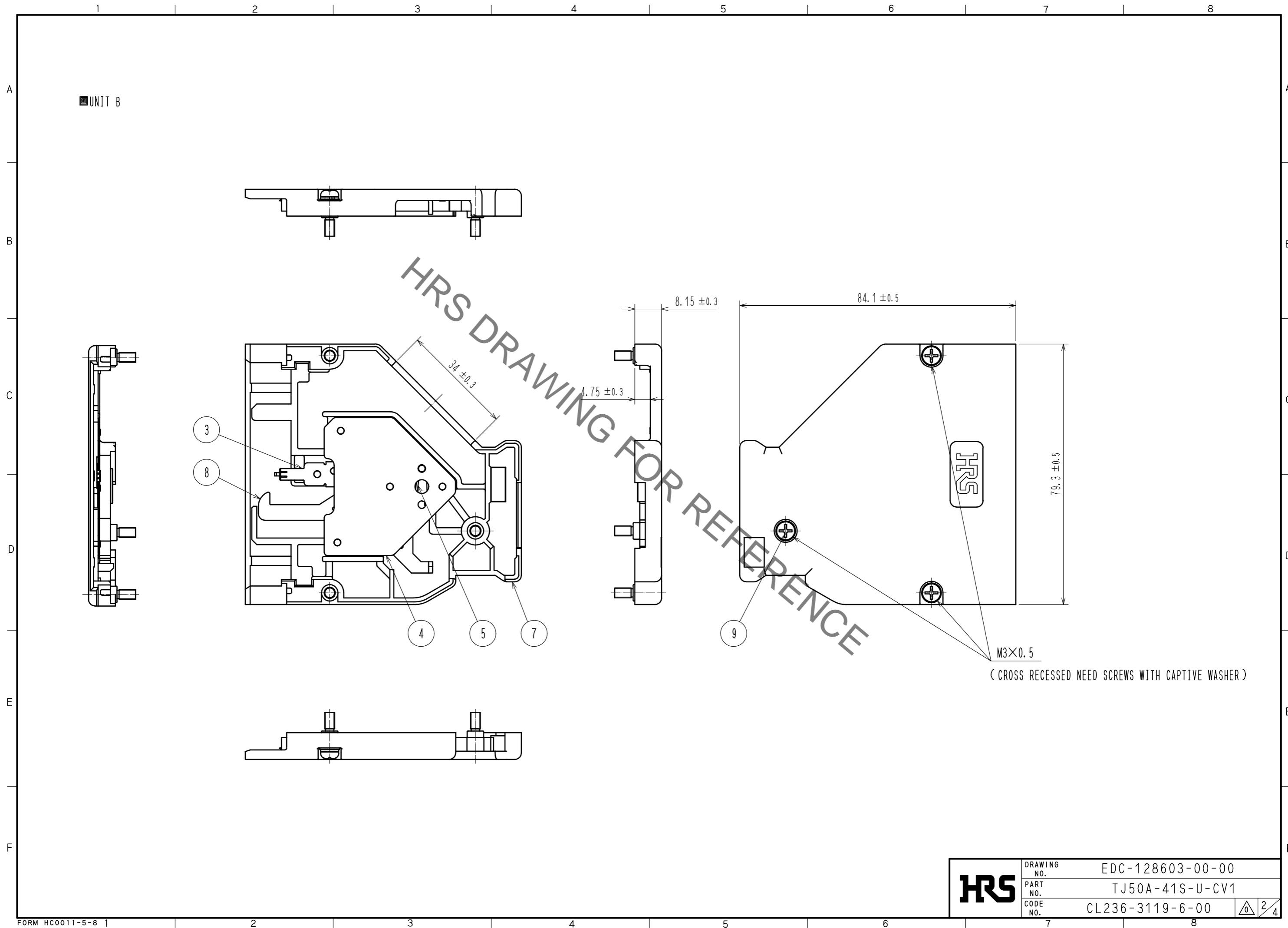

<b>HRS</b>	DRAWING NO.	EDC-128603-00-00
	PART NO.	TJ50A-41S-U-CV1
	CODE NO.	CL236-3119-6-00
		2/4

Jul.1.2019 Copyright 2019 HIROSE ELECTRIC CO., LTD. All Rights Reserved.  
 In case of consideration for using Automotive equipment / device which demand high reliability, kindly contact our sales window correspondents.

■ FEMALE HOUSING U ( ATTACHED PARTS )

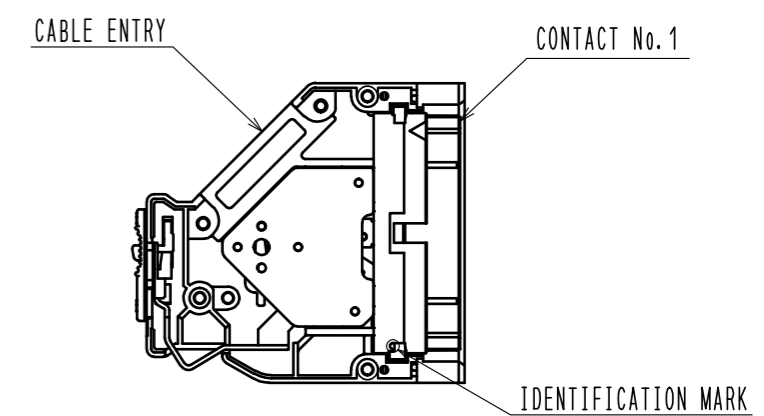
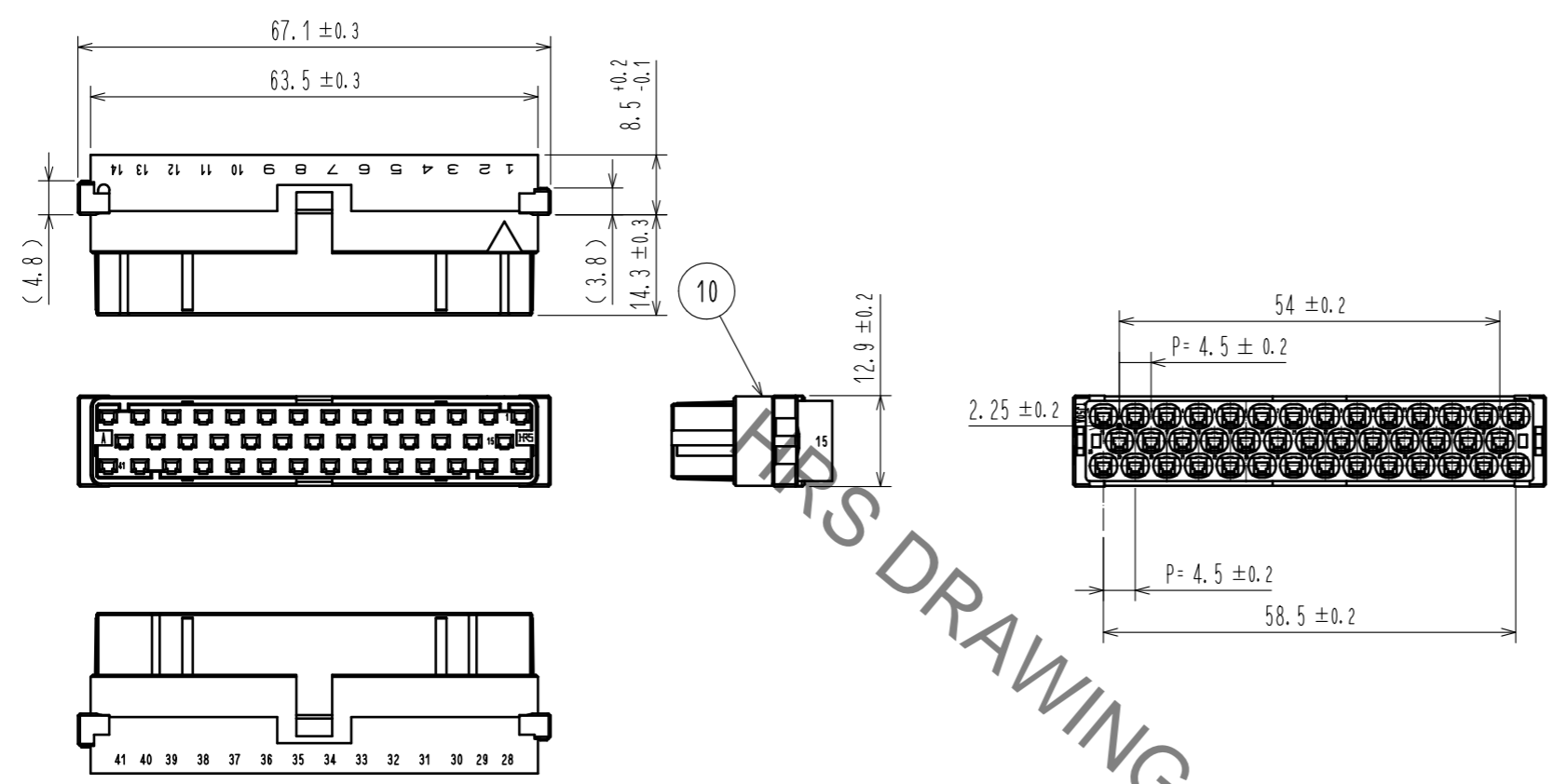
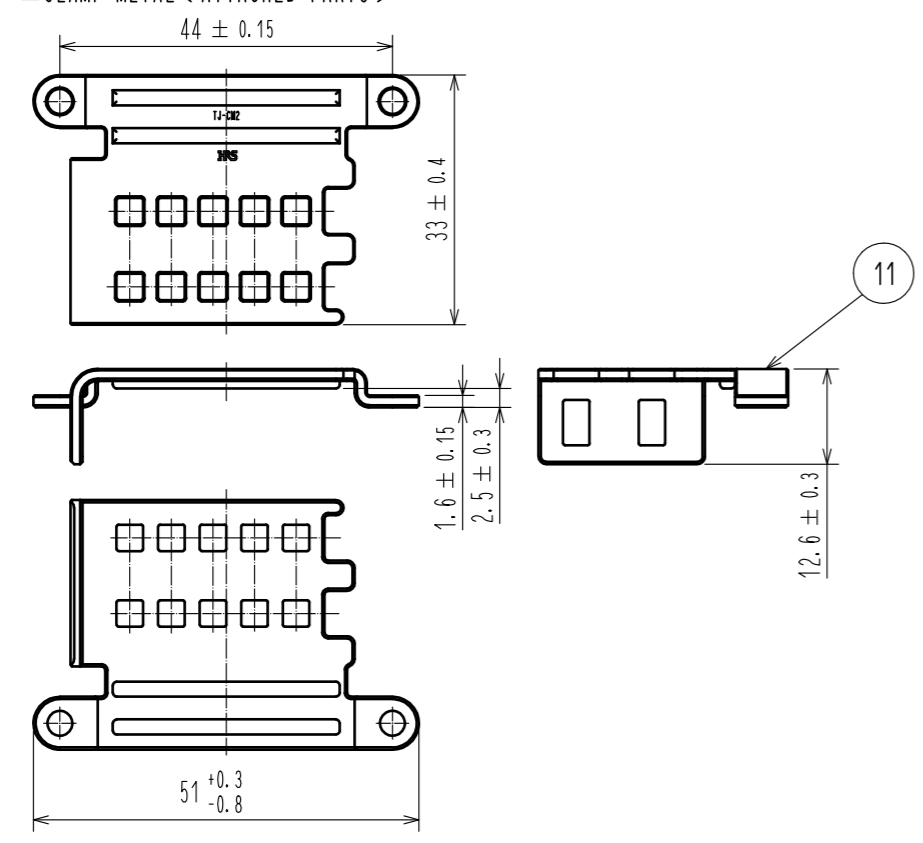
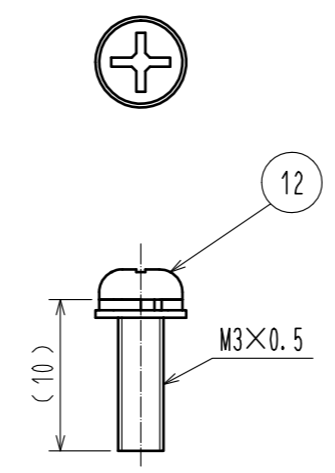

FIG. 1 ASSEMBLY DRAWING (1:2)

■ CLAMP METAL ( ATTACHED PARTS )



■ SCREW FOR CLAMP METAL ( ATTACHED PARTS ) ( 2:1 )  
 ( CROSS RECESSED NEED SCREWS WITH CAPTIVE WASHER )



THIS DRAWING FOR REFERENCE

<b>HRS</b>	DRAWING NO.	EDC-128603-00-00	3/4
	PART NO.	TJ50A-41S-U-CV1	
	CODE NO.	CL236-3119-6-00	

Jul.1.2019 Copyright 2019 HIROSE ELECTRIC CO., LTD. All Rights Reserved.  
 In case of consideration for using Automotive equipment / device which demand high reliability, kindly contact our sales window correspondents.

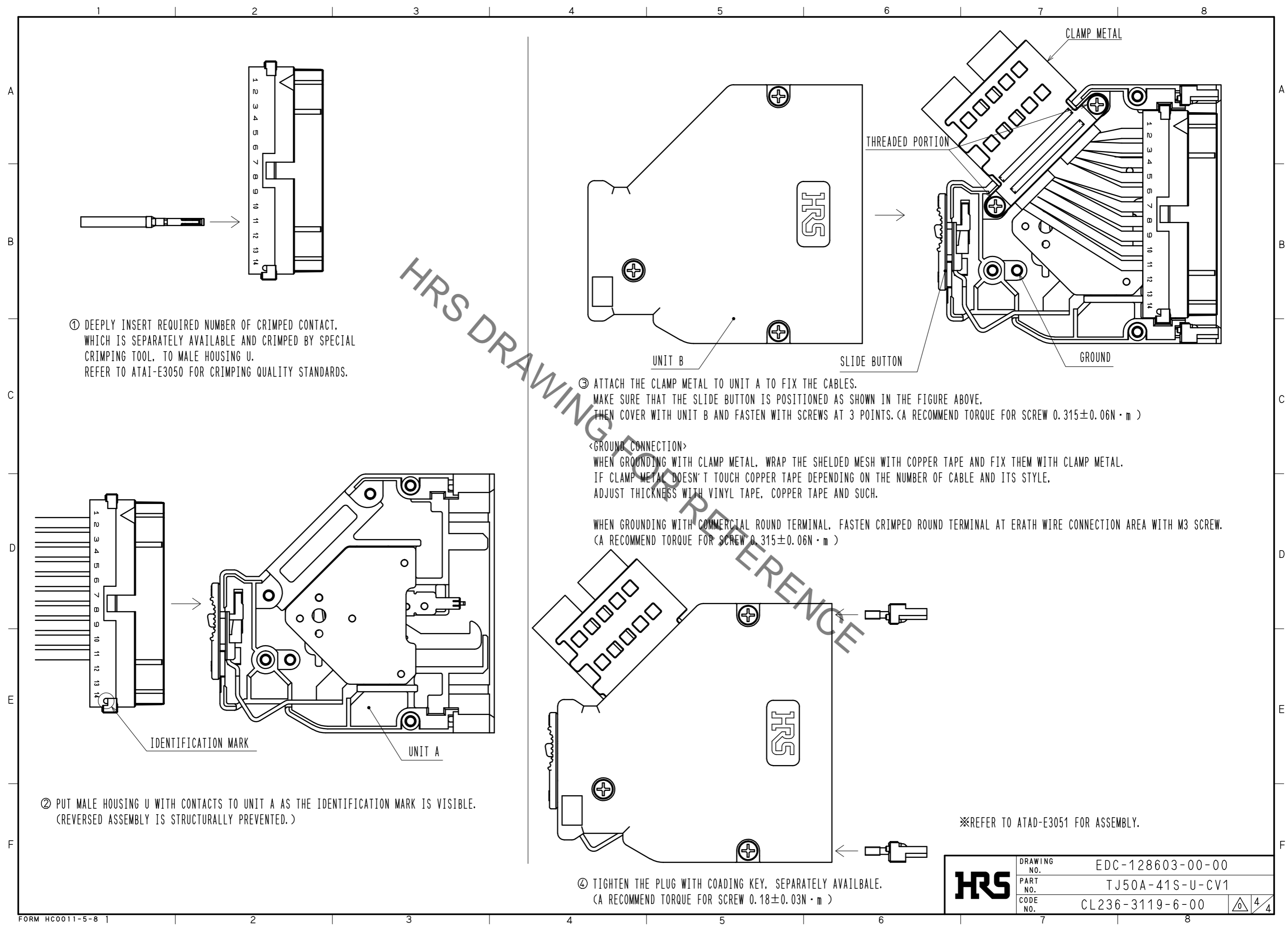

① DEEPLY INSERT REQUIRED NUMBER OF CRIMPED CONTACT, WHICH IS SEPARATELY AVAILABLE AND CRIMPED BY SPECIAL CRIMPING TOOL, TO MALE HOUSING U. REFER TO ATAI-E3050 FOR CRIMPING QUALITY STANDARDS.

③ ATTACH THE CLAMP METAL TO UNIT A TO FIX THE CABLES. MAKE SURE THAT THE SLIDE BUTTON IS POSITIONED AS SHOWN IN THE FIGURE ABOVE, THEN COVER WITH UNIT B AND FASTEN WITH SCREWS AT 3 POINTS. (A RECOMMEND TORQUE FOR SCREW  $0.315 \pm 0.06N \cdot m$ )

<GROUND CONNECTION>  
 WHEN GROUNDING WITH CLAMP METAL, WRAP THE SHIELDED MESH WITH COPPER TAPE AND FIX THEM WITH CLAMP METAL. IF CLAMP METAL DOESN'T TOUCH COPPER TAPE DEPENDING ON THE NUMBER OF CABLE AND ITS STYLE, ADJUST THICKNESS WITH VINYL TAPE, COPPER TAPE AND SUCH.

WHEN GROUNDING WITH COMMERCIAL ROUND TERMINAL, FASTEN CRIMPED ROUND TERMINAL AT ERATH WIRE CONNECTION AREA WITH M3 SCREW. (A RECOMMEND TORQUE FOR SCREW  $0.315 \pm 0.06N \cdot m$ )

② PUT MALE HOUSING U WITH CONTACTS TO UNIT A AS THE IDENTIFICATION MARK IS VISIBLE. (REVERSED ASSEMBLY IS STRUCTURALLY PREVENTED.)

④ TIGHTEN THE PLUG WITH COADING KEY, SEPARATELY AVAILBALE. (A RECOMMEND TORQUE FOR SCREW  $0.18 \pm 0.03N \cdot m$ )

※REFER TO ATAD-E3051 FOR ASSEMBLY.

<b>HRS</b>	DRAWING NO.	EDC-128603-00-00	4/4
	PART NO.	TJ50A-41S-U-CV1	
	CODE NO.	CL236-3119-6-00	

## Данный компонент на территории Российской Федерации

### Вы можете приобрести в компании MosChip.

Для оперативного оформления запроса Вам необходимо перейти по данной ссылке:

<http://moschip.ru/get-element>

Вы можете разместить у нас заказ для любого Вашего проекта, будь то серийное производство или разработка единичного прибора.

В нашем ассортименте представлены ведущие мировые производители активных и пассивных электронных компонентов.

Нашей специализацией является поставка электронной компонентной базы двойного назначения, продукции таких производителей как XILINX, Intel (ex.ALTERA), Vicor, Microchip, Texas Instruments, Analog Devices, Mini-Circuits, Amphenol, Glenair.

Сотрудничество с глобальными дистрибьюторами электронных компонентов, предоставляет возможность заказывать и получать с международных складов практически любой перечень компонентов в оптимальные для Вас сроки.

На всех этапах разработки и производства наши партнеры могут получить квалифицированную поддержку опытных инженеров.

Система менеджмента качества компании отвечает требованиям в соответствии с ГОСТ Р ИСО 9001, ГОСТ РВ 0015-002 и ЭС РД 009

### Офис по работе с юридическими лицами:

105318, г.Москва, ул.Щербаковская д.3, офис 1107, 1118, ДЦ «Щербаковский»

Телефон: +7 495 668-12-70 (многоканальный)

Факс: +7 495 668-12-70 (доб.304)

E-mail: [info@moschip.ru](mailto:info@moschip.ru)

Skype отдела продаж:

moschip.ru

moschip.ru\_4

moschip.ru\_6

moschip.ru\_9