



ACCESSOIRES POUR FIXATION SUR STRUCTURE



FIXING ACCESSORIES

Edition 01/13

Amphenol Air LB

SYSTEMES DE CONNEXIONS ELECTRIQUES ET ELECTRONIQUES
ELECTRIC AND ELECTRONIC CONNECTION SYSTEMS

SOMMAIRE

TABLE OF CONTENTS



ACCESSOIRES POUR FIXATION Série ABS	5	<u>ABS Series FIXING ACCESSORIES</u>
<u>Supports de Fixation pour Isolation - ABS 1106</u>	7	<u>ABS 1106 Insulation fixing systems</u>
Présentation	8	<i>Presentation</i>
Caractéristiques Techniques	8	<i>Technical data</i>
Support ABS 1106A31 - Type 1	9	<i>ABS 1106A31 system - Type 1</i>
Support ABS 1106B40 - Type 2	9	<i>ABS 1106B40 system - Type 2</i>
<u>Supports de fixation - ABS 1339</u>	11	<u>ABS 1339 - Fixing systems</u>
Présentation	12	<i>Presentation</i>
Caractéristiques Techniques	12	<i>Technical data</i>
Supports ABS 1339	13	<i>ABS 1339 systems</i>
<u>Supports de fixation - ABS 1424</u>	15	<u>ABS 1424 - Fixing systems</u>
Présentation	16	<i>Presentation</i>
Caractéristiques Techniques	17	<i>Technical data</i>
Support ABS 1424-4-10 - Type 1	17	<i>ABS 1424-4-10 system - Type 1</i>
Support ABS 1424-5-7 - Type 2	17	<i>ABS 1424-5-7 system - Type 2</i>
<u>Supports de fixation - ABS 1688</u>	19	<u>ABS 1688 - Fixing systems</u>
Présentation	20-21	<i>Presentation</i>
Caractéristiques Techniques	22	<i>Technical data</i>
Supports ABS 1688 - Type B	22	<i>ABS 1688 systems - Type B</i>
Supports ABS 1688 - Type C	23	<i>ABS 1688 systems - Type C</i>
Supports ABS 1688 - Type D	24	<i>ABS 1688 systems - Type D</i>
<u>Supports de fixation - ABS 1694</u>	25	<u>ABS 1694 - Fixing systems</u>
Présentation	26	<i>Presentation</i>
Caractéristiques Techniques	26	<i>Technical data</i>
Support ABS 1694 - Type N	27-28	<i>ABS 1694 system - Type N</i>
Support ABS 1694 - Type O	28	<i>ABS 1694 system - Type O</i>
Support ABS 1694 - Type P	29	<i>ABS 1694 system - Type P</i>
Support ABS 1694 - Type R	29	<i>ABS 1694 system - Type R</i>
Support ABS 1694 - Type S	30	<i>ABS 1694 system - Type S</i>
<u>Supports de fixation - ABS 1695</u>	31	<u>ABS 1695 - Fixing systems</u>
Présentation	32	<i>Presentation</i>
Caractéristiques Techniques	32	<i>Technical data</i>
Supports ABS 1695 - Type A05	33	<i>ABS 1695 systems - Type A05</i>
Support ABS 1695 - Type A06	33	<i>ABS 1695 system - Type A06</i>
Support ABS 1695 - Type A07	34	<i>ABS 1695 system - Type A07</i>
<u>Supports de fixation - ABS 2225</u>	35	<u>ABS 2225 - Fixing systems</u>
Présentation	36	<i>Presentation</i>
Caractéristiques Techniques	37	<i>Technical data</i>
Supports ABS 2225 - Equerres	37	<i>ABS 2225 systems - Adapters</i>
Supports ABS 2225 - Barres	38	<i>ABS 2225 systems - Body</i>
<u>ACCESSOIRES DE CABLAGE</u>	39	<u>WIRING ACCESSORIES</u>
Présentation	40	<i>Presentation</i>
Caractéristiques techniques	40	<i>Technical data</i>
Supports droits	41-42	<i>Straight supports</i>
Supports coudés	43-45	<i>Angles supports</i>
Supports pour applications spécifiques	46-47	<i>Cable supports for specific applications</i>
Supports en ligne	48	<i>Harness tiedown strip</i>
Supports pour harnais de câbles	49	<i>Harness supports</i>
Hat supports pour harnais de câbles	50	<i>Hat supports for cable assemblies</i>
Séparateur ABS 1144	51	<i>ABS 1144 separator</i>
<u>COLLIERS DE CHEMINEMENT série P et OMEGA</u>	53	<u>CABLE CLAMPS P and OMEGA series</u>
Présentation	54	<i>Presentation</i>
Colliers de cheminement - série LDG P	55	<i>LDG P series - Cable clamps</i>
Colliers de cheminement - série P	56	<i>P series - Cable clamps</i>
Colliers de cheminement - série OMEGA	57	<i>OMEGA series - Cable clamps</i>
<u>REFERENTIEL GENERAL</u>	59-63	<u>GENERAL PART NUMBERING</u>



 **NOUVEAU / NEW**

Accessoires pour fixation Série ABS



ABS series
Fixing accessories



Edition 01/13

Amphenol Air LB

SYSTEMES DE CONNEXIONS ELECTRIQUES ET ELECTRONIQUES
ELECTRIC AND ELECTRONIC CONNECTION SYSTEMS



SUPPORTS DE FIXATION POUR ISOLATION - ABS 1106



ABS 1106 **INSULATION FIXING SYSTEMS**



Edition 01/13

Amphenol Air LB

SYSTEMES DE CONNEXIONS ELECTRIQUES ET ELECTRONIQUES
ELECTRIC AND ELECTRONIC CONNECTION SYSTEMS

PRESENTATION PRESENTATION



Ces nouveaux systèmes de fixation, pour isolation phonique et thermique, qualifiés suivant la Norme Airbus ABS 1106, sont conçus et développés par Amphenol Air LB selon 2 types :

- Type 1 : ABS 1106A31, fixé sur pion ABS 1423 (non fourni)
- Type 2 : ABS 1106B40, fixé sur pion ABS 1105 (non fourni)

According to ABS 1106 Airbus standard, Amphenol AIR LB design 2 types of fixing systems, for phonic and thermic insulation :

- Type 1 : ABS 1106A31, fixing on ABS 1423 pin (not supplied)
- Type 2 : ABS 1106B40, fixing on ABS 1105 pin (not supplied)



LÉGENDE :

- ① Isolant
- ② Support de fixation ABS 1106 type 1
- ③ Intercalaire
- ④ Collier serre-câbles ABS 1339
- ⑤ Toron de câbles
- ⑥ Support de fixation ABS 1106 type 2

CAPTION :

- ① Insulator
- ② ABS 1106 fixing system - type 1
- ③ Spacer
- ④ ABS 1339 cable clamp
- ⑤ Cables
- ⑥ ABS 1106 fixing system - type 2

Nos systèmes de fixation ABS 1106 répondent aux Exigences ROHS et REACH.

ABS 1106 are conform to ROHS and REACH requirements.



CARACTERISTIQUES TECHNIQUES TECHNICAL DATA

MECANIQUES

Matière : Thermoplastique noir
Chocs : Catégorie E de la RTCA/DO-160G
Vibrations : Courbe C et C1 de la RTCA/DO-160G
Endurance : 30 cycles complets de montage/démontage sur structure
Charges Statiques : 200N dans les 3 axes

CLIMATIQUES

Température d'utilisation : -55°C à +85°C

RESISTANCE AUX FLUIDES

NATO F44, AS 1241, MIL PRF 680 (type 1), 5606, 7870, 23699, 87937 (dilué), 87252 et AMS 1428

COMPORTEMENT FEU / FUMÉE

Conforme à la norme ABD031

MECHANICAL

Material : Black thermoplastic
Shocks : RTCA/DO-160G Catégorie E
Vibrations : RTCA/DO-160G Curve C and C1
Endurance : 30 full mounting/unmounting cycles (on panel)
Static loads : 200N in 3 axis

ENVIRONMENT

Operating temperature : -55°C to +85°C

FLUIDS RESISTANCE

NATO F44, AS 1241, MIL PRF 680 (type 1), 5606, 7870, 23699, 87937 (diluted), 87252 and ASM 1428

FLAMMABILITY

Conform to ABD031 standard

SUPPORT ABS 1106A31 - Type 1

ABS 1106A31 SYSTEM - Type 1



Réf. AALBF AALBF PN	Norme Standard	Masse Weight
		g $\pm 5\%$
3540 0005 356	ABS1106A31	0,49

SUPPORT ABS 1106B40 - Type 2

ABS 1106B40 SYSTEM - Type 2



Réf. AALBF AALBF PN	Norme Standard	Masse Weight
		g $\pm 5\%$
3540 0030 356 SCS	ABS1106B40	1



SUPPORTS DE FIXATION ABS 1339



ABS 1339 FIXING SYSTEMS



Edition 01/13

Amphenol Air LB

SYSTEMES DE CONNEXIONS ELECTRIQUES ET ELECTRONIQUES
ELECTRIC AND ELECTRONIC CONNECTION SYSTEMS

PRESENTATION PRESENTATION



AVANTAGES

- Maintien des torons de câble par pré-clipsage
- Protection des torons de câbles aux vibrations par élastomère surmoulé (3)
- Matériaux utilisés non-corrosifs et non-conducteurs
- Marquage individuel pour reconnaissance facile et rapide
- Conformés aux Exigences ROHS et REACH



ADVANTAGES

- Keeping of electrical bundle by pre-clips
- Protection of electrical bundle from vibrations by over-molded elastomer (3)
- Individual marking for easy and fast identification
- Non-corrosive and non-conductive materials
- Conform to ROHS and REACH requirements

DISPOSITION GENERALE

- Fixation des colliers serre-câbles sur parois par vis (1)
- Fermeture des colliers ABS 1339 par un attache-câble remplaçable (4)
- Colliers serre-câbles disponibles en huit tailles pour les diamètres 5 à 48 mm
- Application pour tous secteurs : industrie, aéronautique, etc...

GENERAL DESIGN

- Fixing of cable clamps on surface by screw (1)
- Closure of ABS 1339 cables clamp by replaceable cable tie (4)
- Cable clamps are available in eight sizes from 0.197 to 1.89 inch. diameters
- Application in all areas : industry, aviation, etc...

LÉGENDE

- (1) Vis (non fournie)
- (2) Collier serre-câbles ABS1339
- (3) Protection élastomère
- (4) Attache câble (non fourni)



CAPTION

- (1) Screw (not supplied)
- (2) ABS1339 Cable clamp
- (3) Elastomer protection
- (4) Cable tie (not supplied)

PRECAUTIONS D'EMPLOI

- Utiliser un ensemble vis-rondelle pour un diamètre de passage de 5 mm, avec un couple de serrage compris entre 0,294 et 0,42 m.daN
- Utiliser un attache-câble d'une largeur de 5,5 mm et le serrer avec une pince de serrage type MS 90387-1 (position 6-8) équivalent à une tension d'environ 120 N.
- Couple de serrage : de 0,294 à 0,42 m.daN

USERS WARNING

- Use a screw-washer for a bar-diameter about 0.2 inch., with a tightening torque from 0,294 to 0,42 m.daN
- Use a cable tie for a bar-width about .21 inch. and clamp it with a torque collet type MS 90387-1 (position 6-8); equal to a tension about 120 N.
- Tightening torque : from 0,294 to 0,42 m.daN

CARACTERISTIQUES TECHNIQUES TECHNICAL DATA

MECANIQUES

Matière : Thermoplastique noir
Protection élastomère : Silicone fluoré
Chocs : 6g dans les 3 axes pendant 11ms
Vibrations : Courbe C et E de la RTCA/DO-160G

MECHANICAL

Material : Black thermoplastic
Elastomer protection : Fluored silicone
Shocks : 6g in 3 axis, during 11ms
Vibrations : RTCA/DO-160G curve C and E

CLIMATIQUES

Température d'utilisation : -55°C à +150°C

ENVIRONMENT

Operating temperature : -55°C to +150°C

RESISTANCE AUX FLUIDES

Version **marron** : NATO F44, AS 1241, MIL PRF 680 (type 1), 5606, 7870, 23699, 87937 (dilué), 87252 et AMS1428
Version **bleu** : Tenue 96h en immersion complète

FLUID RESISTANCE

Brown version : NATO F44, AS 1241, MIL PRF 680 (type 1), 5606, 7870, 23699, 87937 (diluted), 87252 and AMS 1428
Blue version : Resistant in complete immersion during 96h

COMPORTEMENT FEU / FUMÉE

Conforme selon la norme ABD031

FLAMMABILITY

Conform to ABD031 standard

SUPPORTS ABS 1339

ABS 1339 SYSTEMS

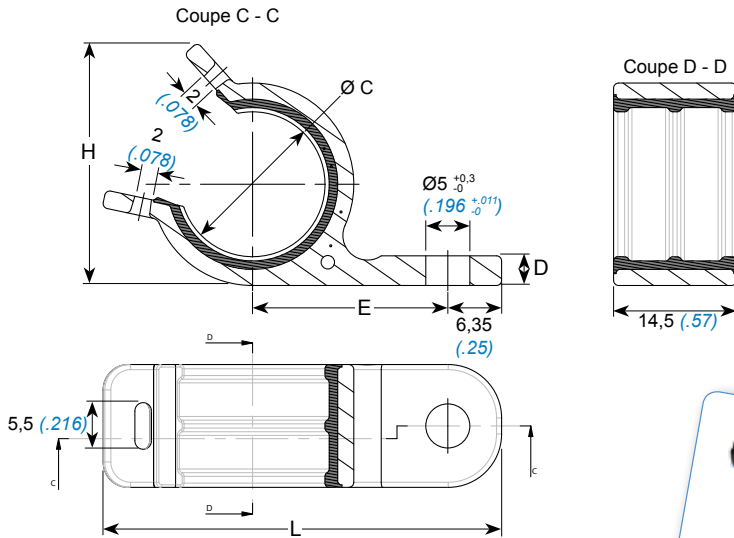

Réf. AALBF AALBF PN	Norme Standard	Couleur Color	Taille Size	ØC Câble admissible Cable allowable		E Entraxe Centre to centre		L Longueur Lenght		H Hauteur Height		D Epaisseur Thickness		Masse Weight g
				mm	inch	mm	inch	mm	inch	mm	inch	mm	inch	
003262 101 00	ABS 1339 D01	marron / brown	01	5 à 7	0.2 to 0.28	17	0.67	34,8	1.37	15,4	0.61	3,5	.14	2,1
003262 111 00	ABS 1339 F01	bleu / blue												
003262 102 00	ABS 1339 D02	marron / brown	02	7 à 10	0.28 to 0.4	18,5	0.73	37,9	1.49	18,7	0.74	3,5	.14	2,5
003262 112 00	ABS 1339 F02	bleu / blue												
003262 103 00	ABS 1339 D03	marron / brown	03	10 à 14	0.4 to 0.55	20,4	0.80	41,5	1.63	23	0.91	3,5	.14	3,2
003262 113 00	ABS 1339 F03	bleu / blue												
003262 104 00	ABS 1339 D04	marron / brown	04	14 à 19,5	0.55 to 0.77	23,05	0.91	47,5	1.87	28,8	1.14	3,5	.14	4,0
003262 114 00	ABS 1339 F04	bleu / blue												
003262 105 00	ABS 1339 D05	marron / brown	05	19,5 à 26,5	0.77 to 1.05	26,75	1.05	54,4	2.14	36	1.42	3,5	.14	5,3
003262 115 00	ABS 1339 F05	bleu / blue												
003262 106 00	ABS 1339 D06	marron / brown	06	26,5 à 35	1.05 to 1.38	31	1.22	62,7	2.47	45	1.77	5,8	.23	8,3
003262 116 00	ABS 1339 F06	bleu / blue												
003262 107 00	ABS 1339 D07	marron / brown	07	35 à 45	1.38 to 1.77	36	1.42	72,3	2.85	54,9	2.16	8,4	.33	11,5
003262 117 00	ABS 1339 F07	bleu / blue												
003262 108 00	ABS 1339 D08	marron / brown	08	39,5 à 48	1.55 to 1.88	40	1.57	81,5	2.86	63,7	2.50	8,3	.32	14,6
003262 118 00	ABS 1339 F08	bleu / blue												

Tolérance générale en référence JS15, masse ± 10 %
Pour toute autre définition, merci de nous consulter.

General tolerance according to JS15, weight ± 10 %
For all others definitions, please contact us.

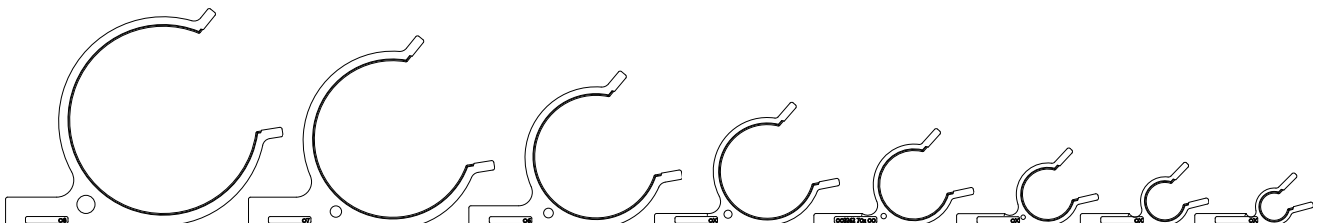



SUPPORTS DE FIXATION ABS 1424



ABS 1424 FIXING SYSTEMS

Edition 01/13



Amphenol Air LB

SYSTEMES DE CONNEXIONS ELECTRIQUES ET ELECTRONIQUES
ELECTRIC AND ELECTRONIC CONNECTION SYSTEMS

PRESENTATION PRESENTATION



Ces nouveaux systèmes de fixation, qualifiés suivant la Norme Airbus ABS 1424, sont conçus et développés par Amphenol Air LB selon 2 types :

- Type 1 : ABS 1424-4-10 avec fixation à vis et rondelle sur structure (non fournie)
- Type 2 : ABS 1424-5-7 avec fixation à pion pour une épaisseur de structure de 1,6 à 2 mm

Ces accessoires permettent la fixation en 360° de Colliers Serre-Câbles ABS 1339, garantissant ainsi un excellent maintien des torons de câbles, quelque soit la configuration de la structure.

According to ABS 1424 Airbus standard, Amphenol AIR LB design 2 types of new fixing systems :

- *Type 1 : ABS 1424-4-10 avec screw and washer fixing (not supplied)*
- *Type 2 : ABS 1424-5-7 with integrated locking pin for a panel thickness from .063 to .079 inch*

ABS 1339 cable clamps can be mounted on ABS 1424 fixing accessories with a 360° configuration to be adapted on all type of panels.

Fixation sur structure des ABS 1424

ABS 1424 panel fixing



LÉGENDE :

- ① Structure
- ② Support de fixation ABS 1424-4-10 avec vis (non fournie)
- ③ Système de fixation pour Collier serre-câbles ABS 1339
- ④ Collier serre-câbles ABS 1339
- ⑤ Toron de câbles

CAPTION :

- ① Panel
- ② ABS 1424-4-10 Screw (not supplied) fixing system
- ③ Fixing system for ABS 1339 cable clamp
- ④ ABS 1339 cable clamp
- ⑤ Cables



LÉGENDE :

- ① Structure
- ② Support de fixation sur ABS 1424-5-7 avec pion intégré
- ③ Système de fixation pour Collier serre-câbles ABS 1339
- ④ Collier serre-câbles ABS 1339
- ⑤ Toron de câbles

CAPTION :

- ① Panel
- ② ABS 1424-5-7 Fixing system with integrated locking pin
- ③ Fixing system for ABS 1339 cable clamp
- ④ ABS 1339 cable clamp
- ⑤ Cables

Nos systèmes de fixation ABS 1424 répondent aux Exigences ROHS et REACH.

ABS 1424 are conform to ROHS and REACH requirements.



CARACTERISTIQUES TECHNIQUES

TECHNICAL DATA



MECANIQUES

Matière : Thermoplastique noir avec insert métallique fileté
 Chocs : Catégorie E de la RTCA/DO-160G
 Vibrations : Type 1 : Courbe E et E1 de la RTCA/DO-160G
 Type 2 : Courbe C et C1 de la RTCA/DO-160G
 Charges Statiques : 200N dans les 3 axes

CLIMATIQUES

Température d'utilisation : Type 1 : -55°C à +130°C
 Type 2 : -55°C à +85°C

RESISTANCE AUX FLUIDES

NATO F44, AS 1241, MIL PRF 680 (type 1), 5606, 7870, 23699, 87937 (dilué), 87252 et AMS 1428

COMPORTEMENT FEU / FUMÉE

Conforme à la norme ABD031

MECHANICAL

Material : Black thermoplastic with metallic threaded insert
 Shocks : RTCA/DO-160G Catégorie E
 Vibrations : Type 1 : RTCA/DO-160G Curve E and E1
 Type 2 : RTCA/DO-160G Curve C and C1
 Static loads : 200N in 3 axis

ENVIRONMENT

Operating temperature : Type 1 : -55°C to +130°C
 Type 2 : -55°C to +85°C

FLUIDS RESISTANCE

NATO F44, AS 1241, MIL PRF 680 (type 1), 5606, 7870, 23699, 87937 (dilued), 87252 and ASM 1428

FLAMMABILITY

Conform to ABD031 standard

SUPPORT ABS 1424-4-10 - TYPE 1

ABS 1424-4-10 SYSTEM - TYPE 1



SUPPORT ABS 1424-5-7 - TYPE 2

ABS 1424-5-7 SYSTEM - TYPE 2

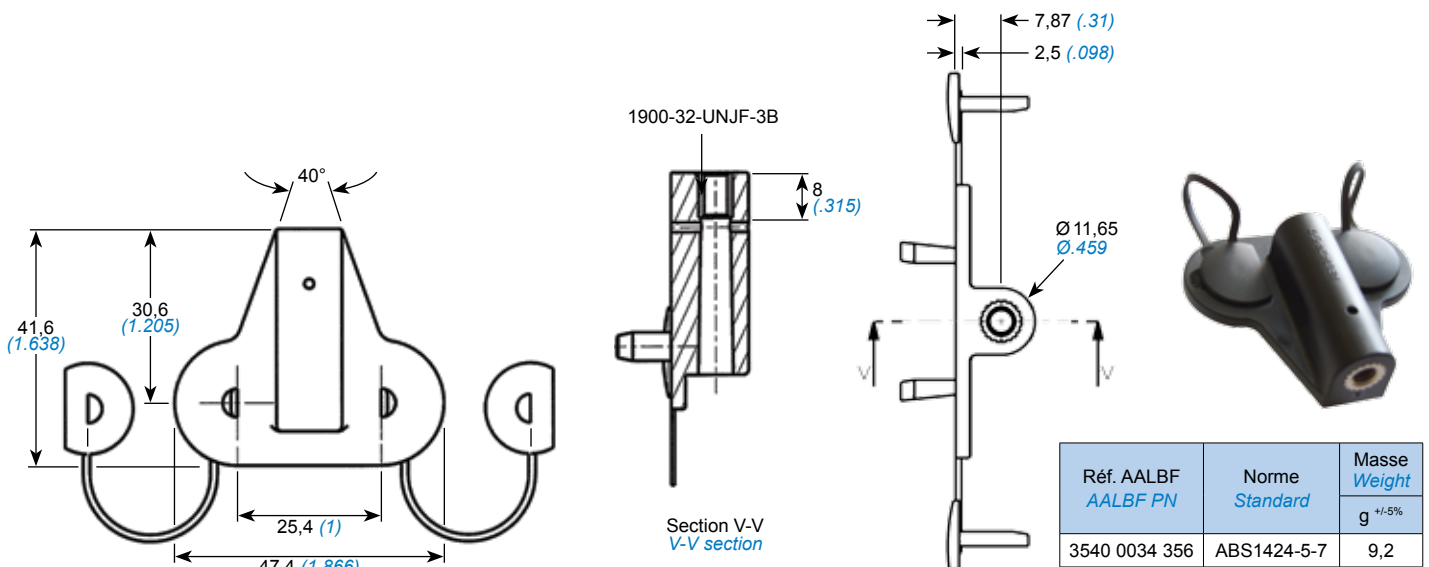



SUPPORTS DE FIXATION ABS 1688



**ABS 1688
FIXING SYSTEMS**



Edition 01/13

Amphenol Air LB

SYSTEMES DE CONNEXIONS ELECTRIQUES ET ELECTRONIQUES
ELECTRIC AND ELECTRONIC CONNECTION SYSTEMS

PRESENTATION PRESENTATION



Ces nouveaux systèmes de fixation pour 2 et 4 tubes, qualifiés suivant la Norme Airbus ABS 1688, sont conçus et développés par Amphenol Air LB selon 3 types : type B, C et D.

According to ABS 1688 Airbus standard, Amphenol AIR LB design 3 types of new fixing systems : B, C and D types.

Supports de Fixation ABS 1688 - Type B et C

- permet la fixation sur structure de 4 tubes de dimensions standards
- s'utilise avec entretoise ABS 1070 (non fournie) pour ajustement du support ABS 1688 par rapport au diamètre du support
- Disponible en 7 versions selon l'épaisseur de structure (4) (de 2 à 9 mm)

ABS 1688 fixing systems - Type B and C

- to fix on panel 4 standard pipes
- to be used with ABS 1070 spacer (not supplied) to adjust the fixing system diameter to the pipe
- available in 7 versions for (4) different panel thickness (from .079 to .354 inch)

Supports de Fixation ABS 1688 - Type D

- permet la fixation sur structure de 2 tubes de dimensions standards
- s'utilise avec entretoise ABS 1070 (non fournie) pour ajustement du support ABS 1688 par rapport au diamètre du tube
- Disponible en 7 versions selon l'épaisseur de structure (4) (de 2 à 9 mm)

ABS 1688 fixing systems - Type D

- to fix on panel 2 standard pipes
- to be used with ABS 1070 spacer (not supplied) to adjust the fixing system diameter to the pipe
- available in 7 versions for (4) different panel thickness (from .079 to .354 inch)

Fixation sur structure des ABS 1688

ABS 1688 panel fixing

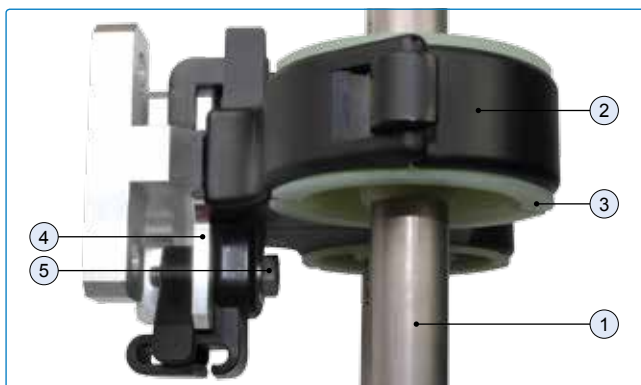

LÉGENDE :

- ① Tube
- ② Support de fixation ABS 1688
- ③ Entretoise ABS 1070 (non fournie)
- ④ Structure
- ⑤ Vis NSA 5191-3 et rondelle NAS 1149 (non fournies)

CAPTION :

- ① Pipe
- ② ABS1688 fixing system
- ③ ABS 1070 Spacer (not supplied)
- ④ Panel
- ⑤ NSA 5191-3 screw and NAS 1149 washer (not supplied)

Couple de serrage : 0,42 m.daN (0,48 m.daN maxi)

Tightening torque : 0,42 m.daN (0,48 m.daN maxi)

Principe de verrouillage des ABS 1688



- 1- Pousser la gachette (G) pour ouvrir l'ABS 1688
- 2- Placer les entretoises ABS 1070
- 3- Fermer l'ABS 1688
- 4- Verrouiller la fermeture de l'ABS 1688 en insérant les goupilles dans les trous prévus à cet effet

ABS 1688 locking instructions



- 1- Push the (G) trigger to open the ABS 1688
- 2- Put the ABS 1070 spacers
- 3- Close the ABS 1688
- 4 - Put the pin into the hole to lock the ABS 1688

Principe de déverrouillage des ABS 1688



- 1- Glisser un tournevis plat entre la goupille et l'ABS 1688
- 2- Effectuer un mouvement levier pour libérer la goupille de son logement
- 3- Répéter le mouvement pour chaque goupille
- 4- L'ABS 1688 est déverrouillé

ABS 1688 unlocking instructions

- 1- Insert a flat screwdriver between the pin and the ABS 1688 support
- 2- Pry the pin to unlock the ABS 1688 support
- 3- Repeat this step for each pin
- 4- The ABS 1688 support is unlocked

Nos systèmes de fixation ABS 1688 répondent aux Exigences ROHS et REACH.



ABS 1688 are conform to ROHS and REACH requirements.

CARACTERISTIQUES TECHNIQUES TECHNICAL DATA



MECANIQUES

Matière : Thermoplastique noir
 Chocs : Catégorie E de la RTCA/DO-160G
 Vibrations : Courbe C et C1 de la RTCA/DO-160G
 Endurance : 10 cycles complets de montage/démontage sur structure
 Charges Statiques : 200N dans les 3 axes

MECHANICAL

Material : Black thermoplastic
 Shocks : RTCA/DO-160G cat. E
 Vibrations : RTCA/DO-160G curve C and C1
 Endurance : 10 full mounting/unmounting cycles (on panel)
 Static loads : 200N in 3 axis

CLIMATIQUES

Température d'utilisation : -55°C à +85°C

ENVIRONMENT

Operating temperature : -55°C to +85°C

RESISTANCE AUX FLUIDES

NATO F44, AS 1241, MIL PRF 680 (type 1), 5606, 7870, 23699, 87937 (dilué), 87252 et AMS1428

FLUID RESISTANCE

NATO F44, AS 1241, MIL PRF 680 (type 1), 5606, 7870, 23699, 87937 (diluted), 87252 and AMS 1428

COMPORTEMENT FEU / FUMÉE

Conforme selon la norme ABD031

FLAMMABILITY

Conform to ABD031 standard

SUPPORTS ABS 1688 - TYPE B ABS 1688 SYSTEMS - TYPE B



Réf. AALBF AALBF PN	Norme Standard	Taille Size	④		Masse Weight g +/-5%
			mm	inch	
3540 8078 000	ABS1688AB01	01	de 2 à 3	from .079 to .118	119,3
3540 8079 000	ABS1688AB02	02	de 3 à 4	from .118 to .157	119,5
3540 8080 000	ABS1688AB03	03	de 4 à 5	from .157 to .197	119,7
3540 8088 000	ABS1688AB04	04	de 5 à 6	from .197 to .236	119,9
3540 8089 000	ABS1688AB05	05	de 6 à 7	from .236 to .275	120,1
3540 8090 000	ABS1688AB06	06	de 7 à 8	from .275 to .315	120,3
3540 8098 000	ABS1688AB07	07	de 8 à 9	from .315 to .354	120,5

SUPPORTS ABS 1688 - TYPE C

ABS 1688 SYSTEMS - TYPE C

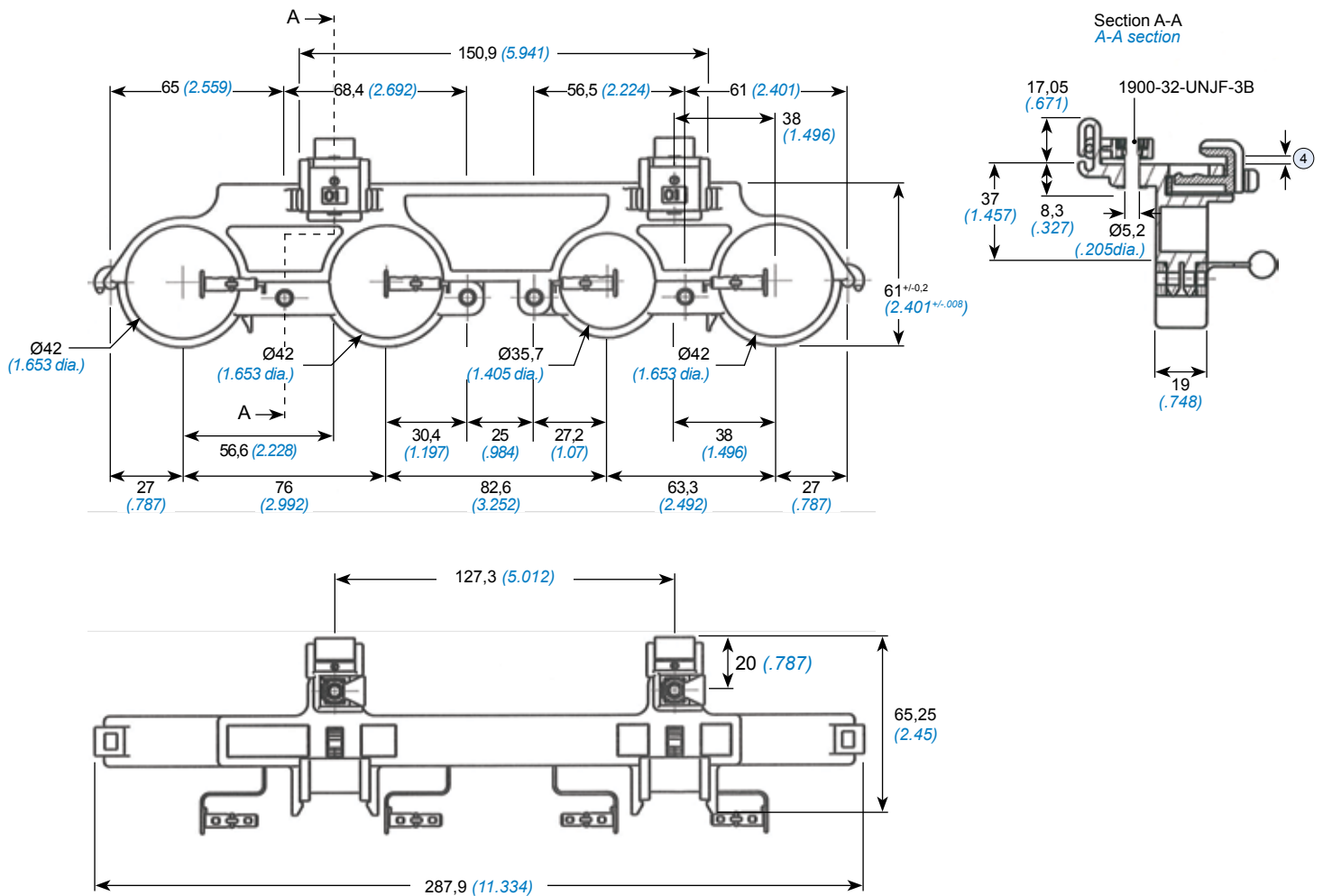

Réf. AALBF AALBF PN	Norme Standard	Taille Size	④		Masse Weight g ^{+/-5%}
			mm	inch	
3540 8081 000	ABS1688AC01	01	de 2 à 3	from .079 to .118	126,8
3540 8082 000	ABS1688AC02	02	de 3 à 4	from .118 to .157	127
3540 8083 000	ABS1688AC03	03	de 4 à 5	from .157 to .197	127,2
3540 8084 000	ABS1688AC04	04	de 5 à 6	from .197 to .236	127,4
3540 8085 000	ABS1688AC05	05	de 6 à 7	from .236 to .275	127,6
3540 8086 000	ABS1688AC06	06	de 7 à 8	from .275 to .315	127,8
3540 8087 000	ABS1688AC07	07	de 8 à 9	from .315 to .354	128



SUPPORTS ABS 1688 - TYPE D

ABS 1688 SYSTEMS - TYPE D

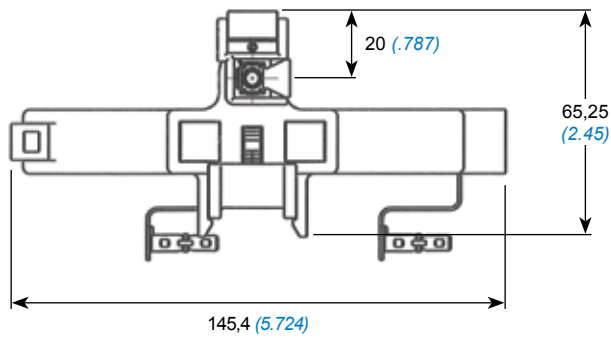
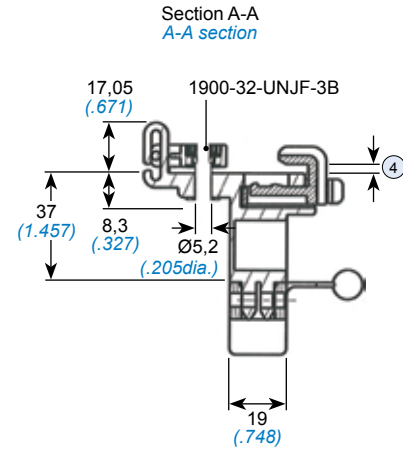
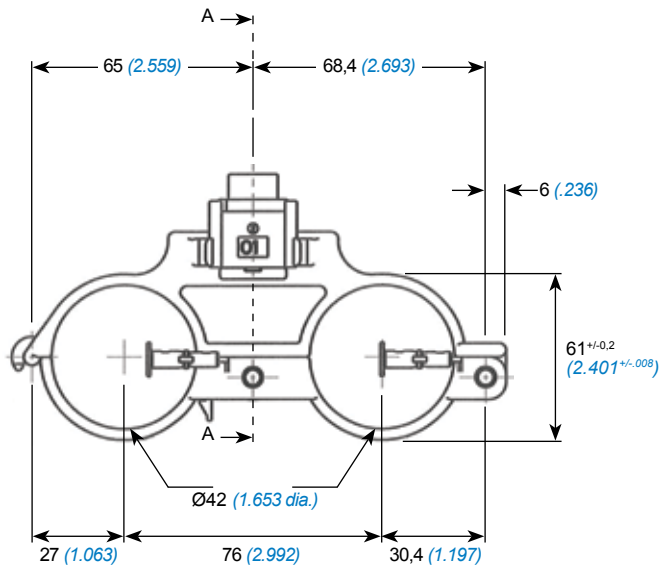

Réf. AALBF AALBF PN	Norme Standard	Taille Size	④		Masse Weight g ^{+/-5%}
			mm	inch	
3540 8091 000	ABS1688AD01	01	de 2 à 3	from .079 to .118	59,3
3540 8092 000	ABS1688AD02	02	de 3 à 4	from .118 to .157	59,4
3540 8093 000	ABS1688AD03	03	de 4 à 5	from .157 to .197	59,5
3540 8094 000	ABS1688AD04	04	de 5 à 6	from .197 to .236	59,6
3540 8095 000	ABS1688AD05	05	de 6 à 7	from .236 to .275	59,7
3540 8096 000	ABS1688AD06	06	de 7 à 8	from .275 to .315	59,8
3540 8097 000	ABS1688AD07	07	de 8 à 9	from .315 to .354	59,9





SUPPORTS DE FIXATION ABS 1694



**ABS 1694
FIXING SYSTEMS**



Edition 01/13

Amphenol Air LB

SYSTEMES DE CONNEXIONS ELECTRIQUES ET ELECTRONIQUES
ELECTRIC AND ELECTRONIC CONNECTION SYSTEMS

PRESENTATION PRESENTATION



Ces nouveaux systèmes de fixation pour supports de tuyauterie, qualifiés suivant la Norme Airbus ABS 1694, sont conçus et développés par Amphenol Air LB selon 5 types :

According to ABS 1694 Airbus standard, Amphenol AIR LB design 5 types of new fixing systems :

Type N	Type O	Type P	Type R	Type S
				
3 modèles / <i>modeles</i>	1 modèle / <i>modele</i>	1 modèle / <i>modele</i>	1 modèle / <i>modele</i>	2 modèles / <i>modeles</i>

Fixation sur structure des ABS 1694

ABS 1694 panel fixing



LÉGENDE :

- ① Structure
- ② Support de fixation ABS 1694
- ③ Système de fixation sur structure (vis+rondelle non fournies)
- ④ Goulotte pour maintien du collier de serrage
- ⑤ Collier de serrage
- ⑥ Support de tuyauterie

CAPTION :

- ① *Panel*
- ② *ABS1694 fixing system*
- ③ *Panel mounting system (screw + washer not supplied)*
- ④ *Spout for ring clamp*
- ⑤ *Ring clamp*
- ⑥ *Pipe clamp*

Nos systèmes de fixation ABS 1694 répondent aux Exigences ROHS et REACH.



ABS 1694 are conform to ROHS and REACH requirements.

CARACTERISTIQUES TECHNIQUES TECHNICAL DATA

MECANIQUES

Matière : Thermoplastique noir
 Chocs : Catégorie E de la RTCA/DO-160G
 Vibrations : Courbe C et C1 de la RTCA/DO-160G
 Charges Statiques : 200N dans les 3 axes

MECHANICAL

Material : Black thermoplastic
 Shocks : RTCA/DO-160G cat. E
 Vibrations : RTCA/DO-160G curve C and C1
 Static loads : 200N in 3 axis

CLIMATIQUES

Température d'utilisation : -55°C à +85°C

ENVIRONMENT

Operating temperature : -55°C to +85°C

RESISTANCE AUX FLUIDES

Types N, O, P et R : NATO F44, AS 1241, MIL PRF 680 (type 1), 5606, 7870, 23699, 87937 (dilué), 87252 et AMS1428
 Type S : tenue 24h en immersion complète

FLUID RESISTANCE

N, O, P and R types : NATO F44, AS 1241, MIL PRF 680 (type 1), 5606, 7870, 23699, 87937 (diluted), 87252 and AMS 1428
 S type : Resistant in complete immersion during 24h

COMPORTEMENT FEU / FUMÉE

Conforme selon la norme ABD031

FLAMMABILITY

Conform to ABD031 standard

SUPPORTS ABS 1694 - TYPE N

ABS 1694 SYSTEMS - TYPE N



Couple de serrage : 0,35 m.daN (0,37 m.daN maxi)

Tightening torque : 0,35 m.daN (0,37 m.daN maxi)

Modèle 1

Modele 1

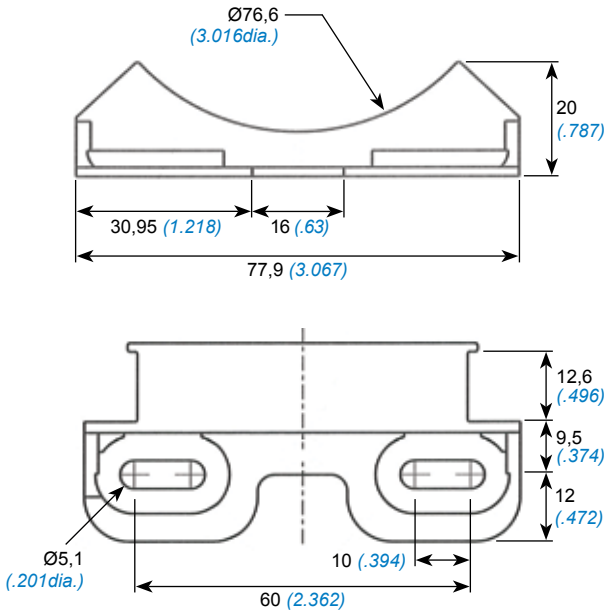

Réf. AALBF AALBF PN	Norme Standard	Masse / Weight g $\pm 10\%$
3540 0032 356	ABS1694A300	8,5

Modèle 2

Modele 2



Réf. AALBF AALBF PN	Norme Standard	Masse / Weight g $\pm 10\%$
3540 0038 356	ABS1694A301	9,1

Modèle 3



Modele 3

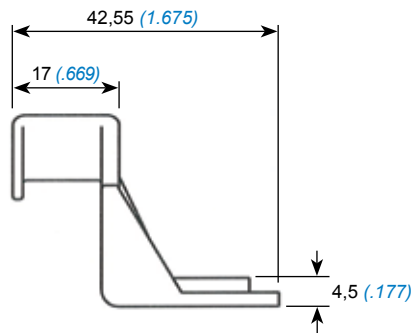

Réf. AALBF AALBF PN	Norme Standard	Masse / Weight
		g $\pm 10\%$
3540 0039 356	ABS1694A302	12,1

SUPPORT ABS 1694 - TYPE O
ABS 1694 SYSTEM - TYPE O

Couple de serrage : 0,35 m.daN (0,37 m.daN maxi)

Tightening torque : 0,35 m.daN (0,37 m.daN maxi)



Réf. AALBF AALBF PN	Norme Standard	Masse / Weight
		g $\pm 10\%$
3540 0033 356	ABS1694A325	12

SUPPORT ABS 1694 - TYPE P

ABS 1694 SYSTEM - TYPE P



Couple de serrage : 0,35 m.daN (0,37 m.daN maxi)

Tightening torque : 0,35 m.daN (0,37 m.daN maxi)

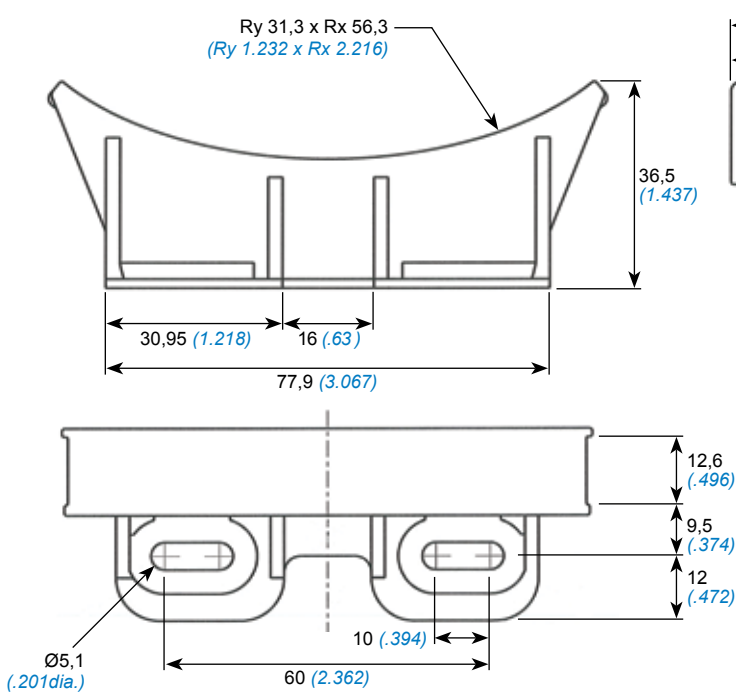

Réf. AALBF AALBF PN	Norme Standard	Masse / Weight
		g $\pm 10\%$
3540 0034 356	ABS1694A350	13,5

SUPPORT ABS 1694 - TYPE R

ABS 1694 SYSTEM - TYPE R



Couple de serrage : 0,35 m.daN (0,37 m.daN maxi)

Tightening torque : 0,35 m.daN (0,37 m.daN maxi)

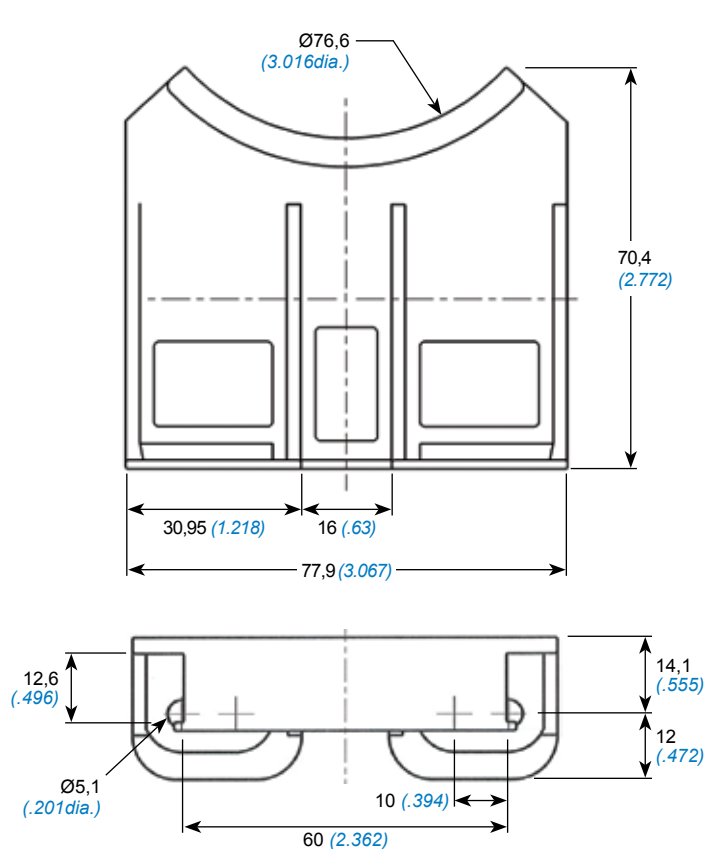

Réf. AALBF AALBF PN	Norme Standard	Masse / Weight
		g $\pm 10\%$
3540 0040 356	ABS1694A375	25

SUPPORT ABS 1694 - TYPE S

ABS 1694 SYSTEM - TYPE S



Couple de serrage : 0,42 m.daN (0,48 m.daN maxi)

Tightening torque : 0,42 m.daN (0,48 m.daN maxi)

Modèle 1

Modele 1

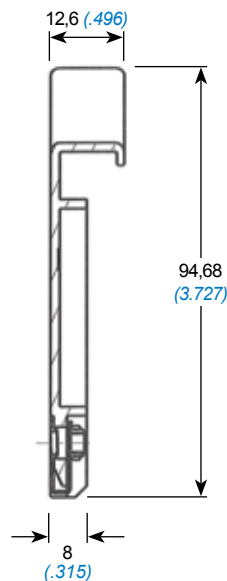

Réf. AALBF AALBF PN	Norme Standard	Masse / Weight
		g ^{+/-10%}
3540 8100 000	ABS1694A400	26,7

Modèle 2

Modele 2

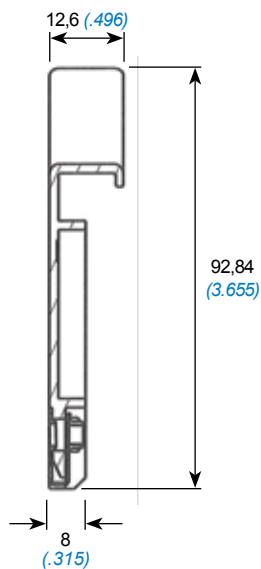
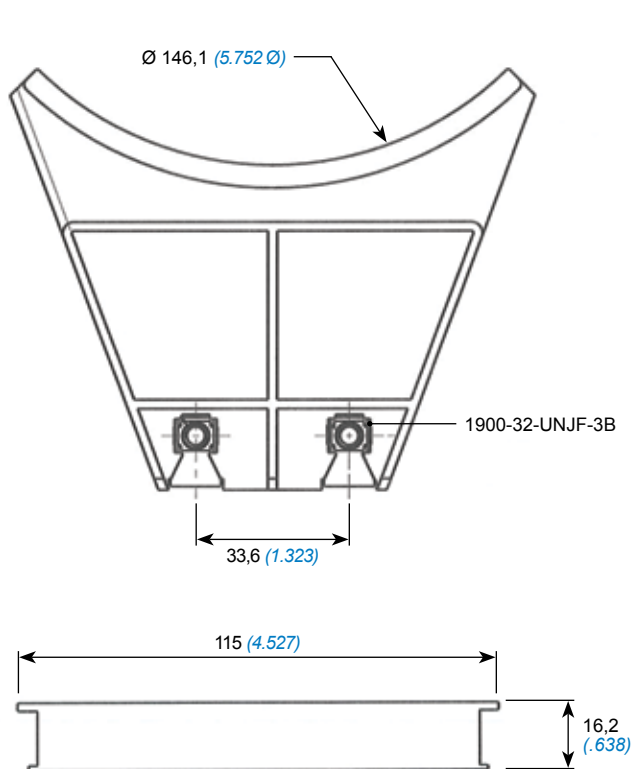

Réf. AALBF AALBF PN	Norme Standard	Masse / Weight
		g ^{+/-10%}
3540 8101 000	ABS1694A401	29,4



SUPPORTS DE FIXATION ABS 1695



ABS 1695 FIXING SYSTEMS

Edition 01/13



Amphenol Air LB

SYSTEMES DE CONNEXIONS ELECTRIQUES ET ELECTRONIQUES
ELECTRIC AND ELECTRONIC CONNECTION SYSTEMS

PRESENTATION PRESENTATION



Ces nouveaux systèmes de fixation pour supports de tuyauterie, qualifiés suivant la Norme Airbus ABS 1695, sont conçus et développés par Amphenol Air LB selon 3 types :

According to ABS 1695 Airbus standard, Amphenol AIR LB design 3 types of new fixing systems :

Type A05	Type A06	Type A07
4 modèles / <i>modelos</i>	1 modèle / <i>modele</i>	1 modèle / <i>modele</i>

Fixation sur structure des ABS 1695

ABS 1695 panel fixing

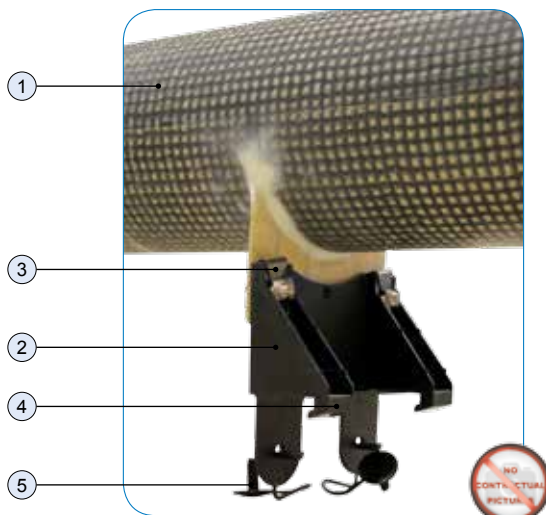

LÉGENDE :

- ① Support de tuyauterie
- ② Support de fixation ABS 1695
- ③ Système de fixation pour tuyauterie (vis et rondelle non fournis)
- ④ Système de fixation sur structure par emprisonnement
- ⑤ Système de verrouillage de la fixation sur structure avec pion intégré

CAPTION :

- ① Pipe clamp
- ② ABS 1695 fixing system
- ③ Fixing system for pipe clamps (screw and nut not supplied)
- ④ ABS 1339 cable clamp
- ⑤ Locking system for fixing system on panel with integrated locking pin

Nos systèmes de fixation ABS 1695 répondent aux Exigences ROHS et REACH.



ABS 1695 are conform to ROHS and REACH requirements.

CARACTERISTIQUES TECHNIQUES TECHNICAL DATA

MECANIQUES

Matière : Thermoplastique noir
 Chocs : Catégorie E de la RTCA/DO-160G
 Vibrations : Courbe C et C1 de la RTCA/DO-160G
 Charges Statiques : 200N dans les 3 axes

MECHANICAL

Material : Black thermoplastic
 Shocks : RTCA/DO-160G cat. E
 Vibrations : RTCA/DO-160G curve C and C1
 Static loads : 200N in 3 axis

CLIMATIQUES

Température d'utilisation : -55°C à +85°C

ENVIRONMENT

Operating temperature : -55°C to +85°C

RESISTANCE AUX FLUIDES

NATO F44, AS 1241, MIL PRF 680 (type 1), 5606, 7870, 23699, 87937 (dilué), 87252 et AMS 1428

FLUID RESISTANCE

NATO F44, AS 1241, MIL PRF 680 (type 1), 5606, 7870, 23699, 87937 (diluted), 87252 and ASM 1428

COMPORTEMENT FEU / FUMÉE

Conforme selon la norme ABD031

FLAMMABILITY

Conform to ABD031 standard

SUPPORTS ABS 1695 - TYPE A05

ABS 1695 SYSTEMS - TYPE A05

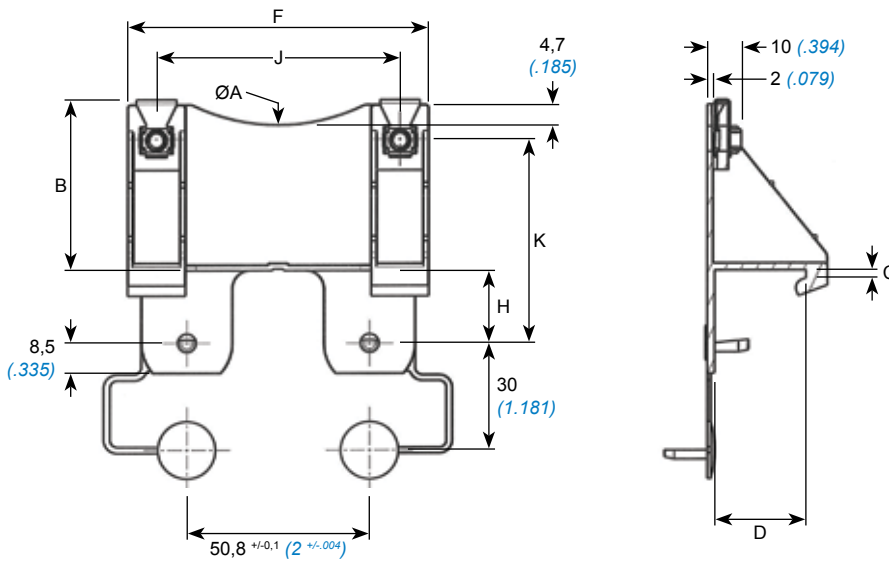

Réf. AALBF AALBF P/N	Norme Standard	ØA		B		C		D		F		H		J		K		Masse Weight g
		mm	inch	mm	inch	mm	inch	mm	inch	mm	inch	mm	inch	mm	inch	mm	inch	
3540 8073 000	ABS1695 A05-01	109,4	4.307	46,2	1.819	2,2	.087	25,5	1.004	83,7	3.295	20,35	.801	67,7	2.665	56,7	2.232	30
3540 8074 000	ABS1695 A05-02	109,4	4.307	36	1.417	1,8	.071	32,5	1.279	83,7	3.295	17,85	.703	67,7	2.665	44	1.732	29
3540 8075 000	ABS1695 A05-03	96,6	3.803	20,1	.791	1,8	.071	32,5	1.279	77,3	3.043	17,85	.703	61,3	2.413	28,1	1.106	23
3540 8076 000	ABS1695 A05-04	96,6	3.803	20,1	.791	2,2	.087	25,5	1.004	77,3	3.043	20,35	.801	61,3	2.413	30,6	1.205	22

SUPPORT ABS 1695 - TYPE A06

ABS 1695 SYSTEM - TYPE A06

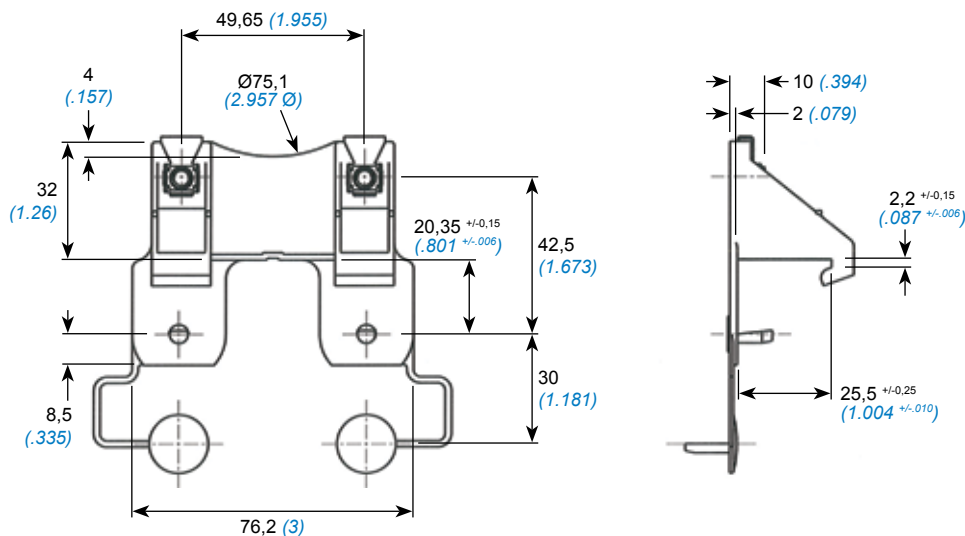

Réf. AALBF AALBF PN	Norme Standard	Masse Weight
3540 8099 000	ABS1695A601	21g

SUPPORT ABS 1695 - TYPE A07

ABS 1695 SYSTEM - TYPE A07

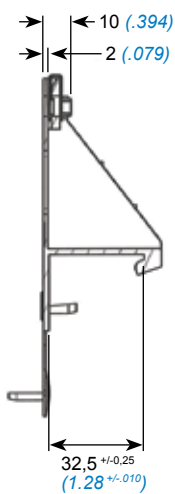

Réf. AALBF AALBF PN	Norme Standard	Masse Weight
3540 8077 000	ABS1695A701	40g



SUPPORTS DE FIXATION ABS 2225



ABS 2225 FIXING SYSTEMS



Edition 01/13

Amphenol Air LB

SYSTEMES DE CONNEXIONS ELECTRIQUES ET ELECTRONIQUES
ELECTRIC AND ELECTRONIC CONNECTION SYSTEMS

PRESENTATION PRESENTATION



Ce nouveau système de fixation, qualifié suivant la Norme Airbus ABS 2225, permettent une fixation en ligne, et sur trois côtés, de torons de câbles ou supports de tuyauterie, grâce à l'utilisation complémentaire de colliers Serre-Câbles ABS 1339.

According to ABS 2225 Airbus standard, Amphenol AIR LB design a new accessory, for an ABS 1339 line mounting, on 3 sides.

Le système de fixation ABS 2225 est composé de :
 - une équerre : positionnable à 0, 90, 180 et 270° selon la structure
 - une barre : mesurant de 32,5 à 607,5 mm et pouvant recevoir un système d'attache complémentaire sur 3 côtés

ABS 2225 consist of :
 - an adapter : for a panel mounting with 0, 90, 180 and 270° swivelling
 - a body : length from 1.279 to 23.917 inch, for ABS 1339 fixing on 3 sides



LÉGENDE :

- ① Barre ABS 2225
- ② Equerre ABS 2225
- ③ Cage écrou de fixation de l'ensemble ABS 2225 (fourni avec la barre)
- ④ Vis/rondelle pour fixation de l'ensemble ABS 2225 (fournis avec l'équerre)

CAPTION :

- ① ABS 2225 body
- ② ABS 2225 adapter
- ③ Clip nut for ABS 2225 fixing (supplied with body)
- ④ Bolt/washer for ABS 2225 fixing (supplied with adapter)

EQUERRE POSITIONNABLE

REMOVABLE ADAPTER

POSITIONS			
0°	90°	180°	270°

PRINCIPE D'UTILISATION

- 1- Desserrer la vis pour permettre à l'embout de pivoter
- 2- Positionner l'embout selon la position souhaitée
- 3- Serrer la vis

Couple de serrage : 0,22 \pm 0,02 m.daN



USE PRINCIPLE

- 1- Unscrew the bolt up to turn the adapter
- 2- Turn the adapter to put it in the desired position
- 3- Re-screwing

Fixing torque : 0,22 \pm 0,02 m.daN

Nos systèmes de fixation ABS 2225 répondent aux Exigences ROHS et REACH.



ABS 2225 are conform to ROHS and REACH requirements.

CARACTERISTIQUES TECHNIQUES

TECHNICAL DATA



MECANIQUES

Matière : Thermoplastique noir
 Chocs : Catégorie E de la RTCA/DO-160G
 Vibrations : Courbe C et C1 de la RTCA/DO-160G
 Endurance : 10 cycles complets de montage/démontage de l'équerre avec la barre
 Charges Statiques : 200N dans les 3 axes

CLIMATIQUES

Température d'utilisation : -55°C à +85°C

RESISTANCE AUX FLUIDES

NATO F44, AS 1241, MIL PRF 680 (type 1), 5606, 7870, 23699, 87937 (dilué), 87252 et AMS 1428

COMPORTEMENT FEU / FUMÉE

Conforme selon la norme ABD031

MECHANICAL

Material : Black thermoplastic
 Shocks : RTCA/DO-160G cat. E
 Vibrations : RTCA/DO-160G curve C and C1
 Endurance : 10 full mounting/unmounting cycles between adapter and body
 Static loads : 200N in 3 axis

ENVIRONMENT

Operating temperature : -55°C to +85°C

FLUID RESISTANCE

NATO F44, AS 1241, MIL PRF 680 (type 1), 5606, 7870, 23699, 87937 (dilued), 87252 and ASM 1428

FLAMMABILITY

Conform to ABD031 standard

SUPPORTS ABS 2225 - EQUERRES

ABS 2225 SYSTEMS - ADAPTER

Vis et rondelles fournies

Screw and washers supplied



Réf. AALBF AALBF P/N	Norme Standard	A		B		C		Masse / Weight g ^{+/- 10%}
		mm	inch	mm	inch	mm	inch	
3540 0131 000	ABS2225A10-01	15	.591	29	1.142	35	1.378	11,7
3540 0132 000	ABS2225A10-02	24	.945	38	1.496	44	1.732	13,2
3540 0133 000	ABS2225A10-03	33	1.299	47	1.850	53	2.086	14,7

SUPPORTS ABS 2225 - BARRES

ABS 2225 SYSTEMS - BODY



Réf. AALBF AALBF P/N	Norme Standard	H		L		Masse / Weight g +/- 10%
		mm	inch	mm	inch	
3540 8201 000	ABS2225A09-01	-	-	32,5	1.279	11
3540 8202 000	ABS2225A09-02	25	.984	57,5	2.264	17
3540 8203 000	ABS2225A09-03	50	1.968	82,5	3.248	23
3540 8204 000	ABS2225A09-04	75	2.953	107,5	4.232	29
3540 8205 000	ABS2225A09-05	100	3.937	132,5	5.216	34
3540 8206 000	ABS2225A09-06	125	4.921	157,5	6.200	39
3540 8207 000	ABS2225A09-07	150	5.905	182,5	7.185	46
3540 8208 000	ABS2225A09-08	175	6.889	207,5	8.169	52
3540 8209 000	ABS2225A09-09	200	7.874	232,5	9.153	58
3540 8210 000	ABS2225A09-10	225	8.858	257,5	10.137	63
3540 8211 000	ABS2225A09-11	250	9.842	282,5	11.122	69
3540 8212 000	ABS2225A09-12	275	10.826	307,5	12.106	75
3540 8213 000	ABS2225A09-13	300	11.811	332,5	13.090	81
3540 8214 000	ABS2225A09-14	325	12.795	357,5	14.074	87
3540 8215 000	ABS2225A09-15	350	13.779	382,5	15.059	93
3540 8216 000	ABS2225A09-16	375	14.763	407,5	16.043	98
3540 8217 000	ABS2225A09-17	400	15.747	432,5	17.027	104
3540 8218 000	ABS2225A09-18	425	16.732	457,5	18.011	110
3540 8219 000	ABS2225A09-19	450	17.716	482,5	18.995	116
3540 8220 000	ABS2225A09-20	475	18.700	507,5	19.980	122
3540 8221 000	ABS2225A09-21	500	19.684	532,5	20.964	127
3540 8222 000	ABS2225A09-22	525	20.669	557,5	21.948	133
3540 8223 000	ABS2225A09-23	550	21.653	582,5	22.932	140
3540 8224 000	ABS2225A09-24	575	22.637	607,5	23.917	145

Bouchon pour Barre ABS 2225

Pin for ABS 2225 Body

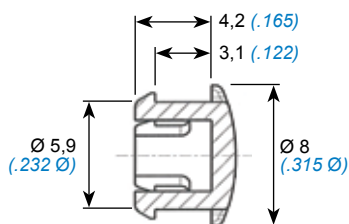

Réf. AALBF AALBF PN	Norme Standard	Masse Weight
3540 0042 356 SCS	ABS2225A12-01	1,5 g +/- 10%



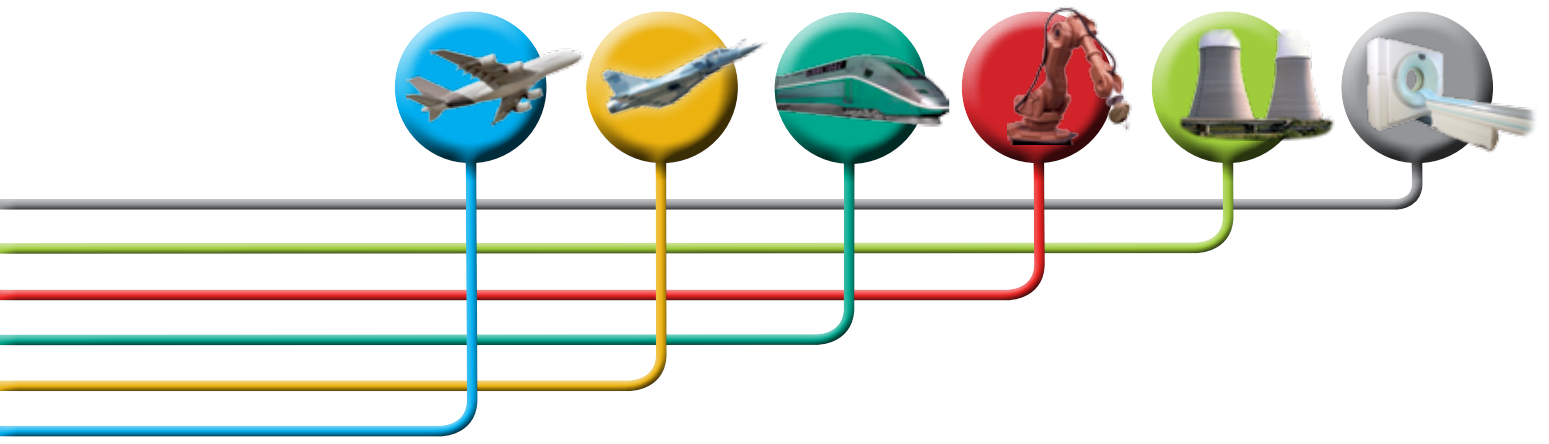

ACCESSOIRES DE CABLAGE

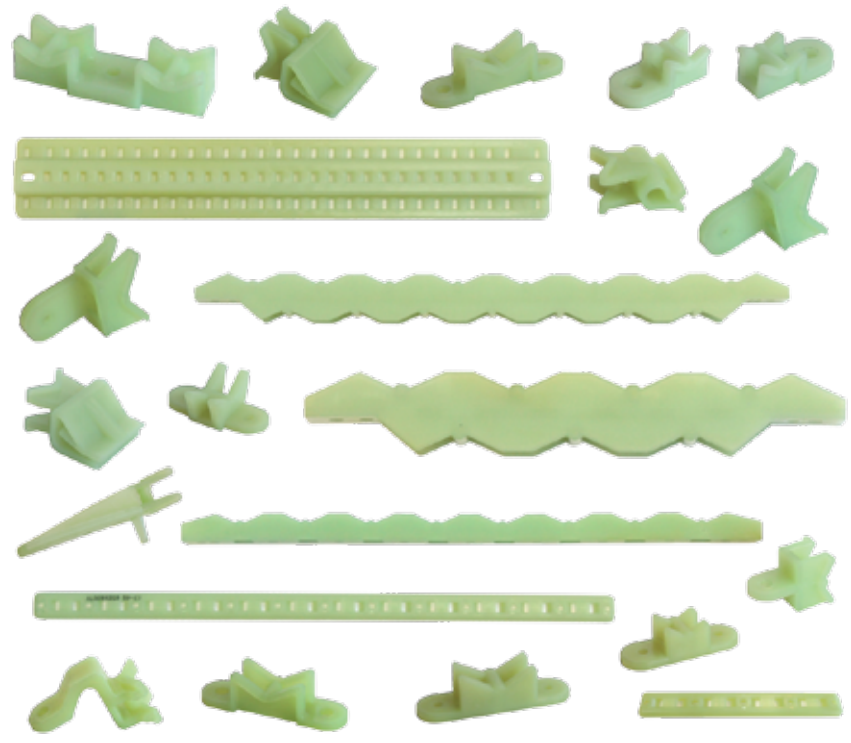

WIRING ACCESSORIES



Edition 01/13

Amphenol Air LB

SYSTEMES DE CONNEXIONS ELECTRIQUES ET ELECTRONIQUES
ELECTRIC AND ELECTRONIC CONNECTION SYSTEMS

CARACTERISTIQUES TECHNIQUES

TECHNICAL DATA



PRINCIPE DE FIXATION

FIXING DESIGN

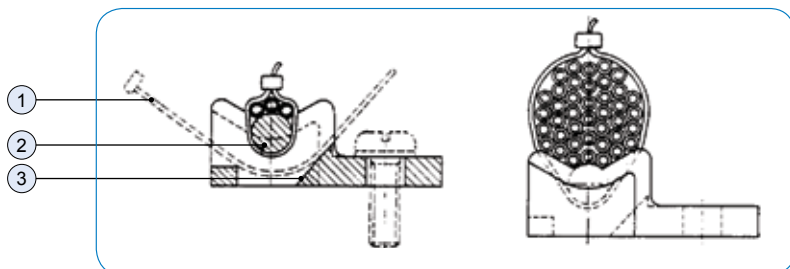

LÉGENDE :

- ① Attache câbles
- ② Cylindre : permet le guidage des câbles, le pré-positionnement et une fixation optimale
- ③ Rampe : facilite l'enfilage rapide de la frette

CAPTION :

- ① Cable tie
- ② Cylindrical support : guides the cables, ensure an optimal fixing
- ③ Ramp : to ease quick feed-in of cable tie

PRECAUTIONS D'EMPLOI

Éliminer tout déshydratant en stockage pour éviter d'altérer les performances.
Les reprises d'humidité du matériau peuvent modifier la coloration de la pièce sans incider sur les propriétés techniques de la matière.

USERS WARNING

*Eliminate any dehydration agent in storage.
If the piece regains its humidity, this may cause a coloration of the material.
Surface coloration does not affect technical properties of the material.*

Nos accessoires de câblage répondent aux Exigences ROHS et REACH.



Wiring accessories are conform to ROHS and REACH requirements.

CARACTERISTIQUES TECHNIQUES

TECHNICAL DATA

MECANIQUES

Matière : Résine thermoplastique
Tolérance générale : +/- 0,25 mm

MECHANICAL

Material : Thermoplastic resin
Tolerance : +/- .01 inch

CLIMATIQUES

Température d'utilisation : -55°C à +135°C

ENVIRONMENT

Operating temperature : -55°C to +135°C

RESISTANCE AUX FLUIDES

ASTM D 543, MIL-T-81533, TT-T-266, TT-M-261, ASTM D 1635, MIL-T-5624, MIL-T-83133

FLUID RESISTANCE

ASTM D 543, MIL-T-81533, TT-T-266, TT-M-261, ASTM D 1635, MIL-T-5624, MIL-T-83133

INFLAMMABILITÉ

Conforme à FAR 25.853 amtd 25-83 (a) et ABD031

FLAMMABILITY

To meet FAR 25.853 amtd 25-83 (a) and ADB031

SUPPORTS DROITS STRAIGHT SUPPORTS



SIMPLE

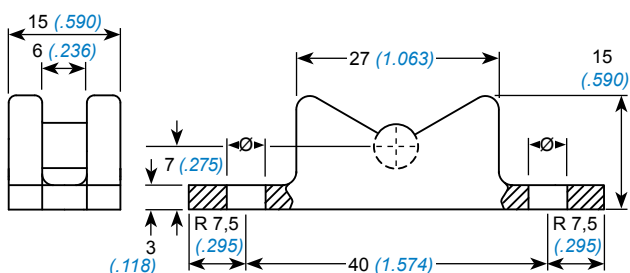

SINGLE

Ø Câblage Ø Wiring	Mini-maxi	Ref. P/N	Sans butée Without block C	Avec butée With block C	Ø		Masse Weight g
					mm	inch	

0.08 to 0.59	2 à 15	(1)	003261 100 59	003261 150 59	5,2	0.2	2,2
		(2)	NSA 935504-01				
	(1)	003261 200 59	003261 250 59	3,3	0.13		

0.08 to 0.59	2 à 15	(3)	ALBCBS 001 05		3,3	0.13	3
--------------------	--------------	-----	---------------	--	-----	------	---

0.08 to 0.59	2 à 30	(1)	003261 102 59	003261 152 59	5,2	0.2	2,2
		(2)	NSA 935504-02				
	(1)	003261 202 59	003261 252 59	3,3	0.13		

0.08 to 1.18	2 à 30	(1)	003261 127 59		5,2	0.2	4,5
		(1)	003261 227 59				
		(3)	ALBCBS 001 06		3,3	0.13	

DOUBLE

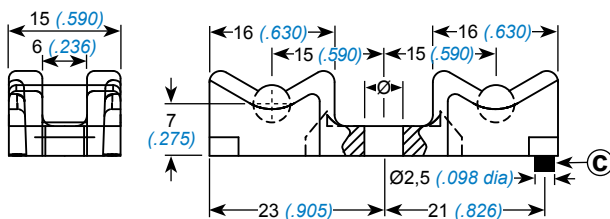

DOUBLE

0.08 to 0.59	2 à 15	(1)	003261 101 59	003261 151 59	5,2	0.2	3,7
		(2)	NSA 935504-03				
		(1)	003261 201 59	003261 251 59	3,3	0.13	
		(3)	NSA 935504-04				

(1) Ref. Amphenol Air LB
(2) Ref. NSA → AIRBUS
(3) Ref. Amphenol Air LB North America

(1) Amphenol Air LB P/N
(2) NSA P/N → AIRBUS
(3) Amphenol Air LB North America P/N

SUPPORTS DROITS STRAIGHT SUPPORTS



SIMPLE



SINGLE

Ø Câblage Ø Wiring	Ref. P/N	Sans butée Without block	Avec butée With block	Ø		Masse Weight
				mm	inch	
Mini-maxi		Ⓢ	Ⓢ			
inch	mm					g



0.08 to 0.59	2 à 15	(1)	003261 114 59		5,2	0.2	2,2
		(1)	003261 113 59	003261 163 59	3,3	0.13	



0.08 to 1.18	2 à 30	(1)		003261 168 59	5,2	0.2	3,2
		(1)		003261 167 59	3,3	0.13	

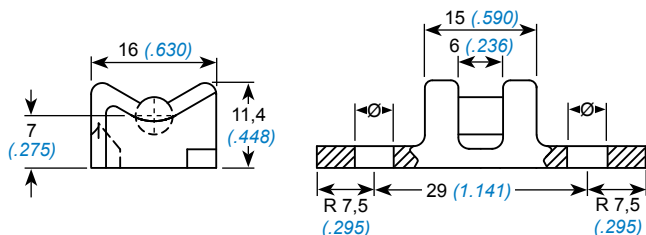

0.08 to 0.59	2 à 15	(1)	003261 173 59		3,3	0.13	3
--------------------	--------------	-----	---------------	--	-----	------	---



0.08 to 1.18	2 à 30	(1)	003261 203 59		3,3	0.13	4,2
--------------------	--------------	-----	---------------	--	-----	------	-----

(1) Ref. Amphenol Air LB

(1) Amphenol Air LB P/N

SUPPORTS COUDES ANGLED SUPPORTS



SIMPLE

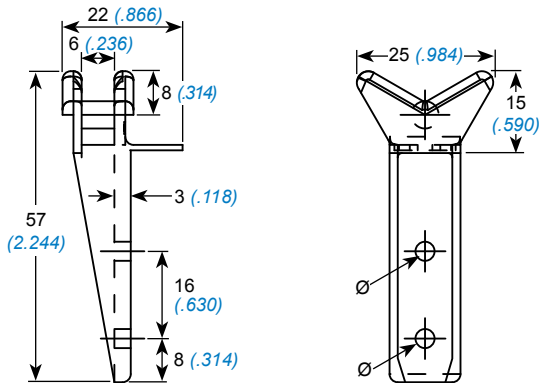

SINGLE

Ø Câblage Ø Wiring	Mini-maxi inch mm	Ref.	Référence Part Number	Ø		Masse Weight g
				mm	inch	
0.08 to 0.59	2 à 30	(1)	003261 501 59	3,2	.125	3,64
		(2)	ASNE 0254-01			
		(1)	003261 511 59	3,5	.137	3,62
		(2)	ASNE 0254-01A			

DOUBLE

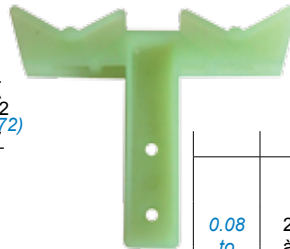
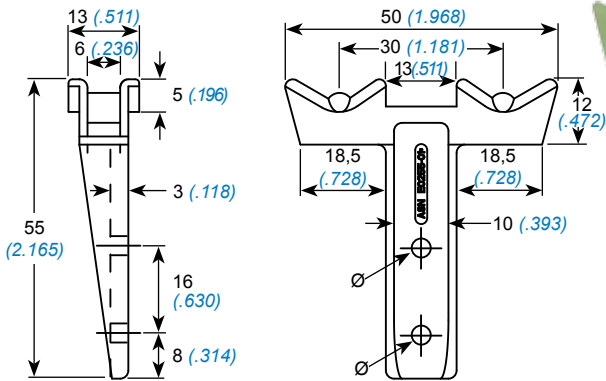

DOUBLE

0.08 to 0.59	2 à 15	(1)	003261 502 59	3,2	.125	4,92
		(2)	ASNE 0255-01			
		(1)	003261 512 59	3,5	.137	4,9
		(2)	ASNE 0255-01A			

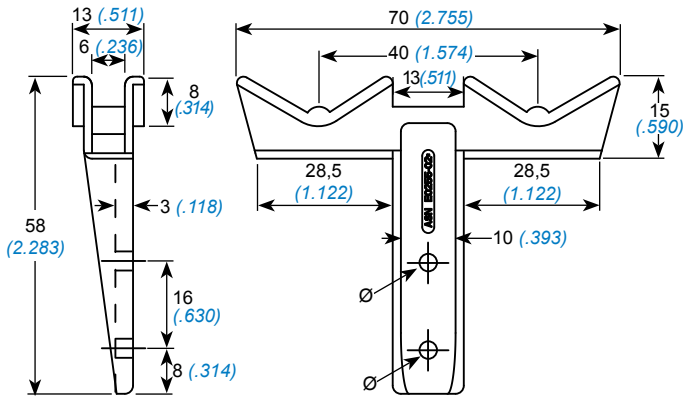

0.08 to 1.18	2 à 30	(1)	003261 503 59	3,2	.125	6,14
		(2)	ASNE 0255-02			
		(1)	003261 513 59	3,5	.137	6,13
		(2)	ASNE 0255-02A			

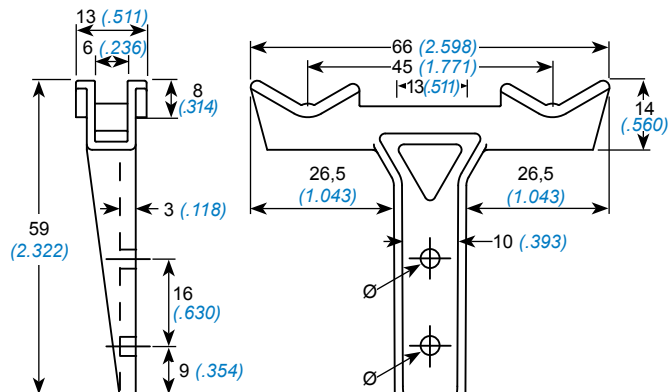

0.08 to 0.787	2 à 20	(1)	003261 515 59	3,5	0.14	6,10
		(2)	ASNE 0255-03A			

(1) Ref. Amphenol Air LB
(2) Ref. NSA → AIRBUS

(1) Amphenol Air LB P/N
(2) NSA P/N → AIRBUS

SUPPORTS COUDES ANGLED SUPPORTS



SIMPLE

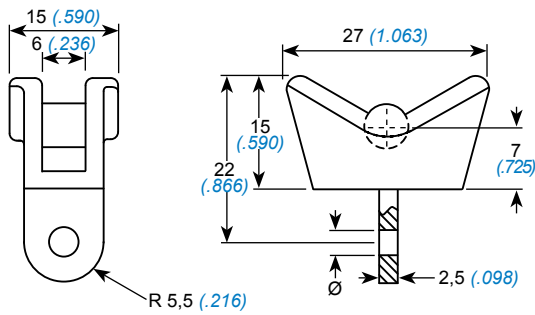
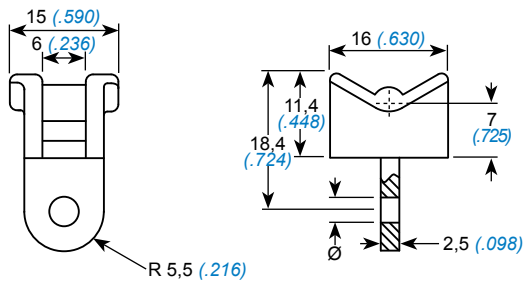

(1) Ref. Amphenol Air LB

SINGLE

Ø Câblage Ø Wiring		Ref.	Référence Part Number	Ø		Masse Weight
Mini-maxi	mm			inch	g	
inch	mm					

0.08 to 0.59	2 à 15	(1)	003261 115 59	3,3	0.13	1,7
--------------------	--------------	-----	---------------	-----	------	-----

0.08 to 1.18	2 à 15	(1)	003261 116 59	3,3	0.13	2,4
--------------------	--------------	-----	---------------	-----	------	-----

(1) Amphenol Air LB P/N

SUPPORTS COUDES ANGLED SUPPORTS



SIMPLE

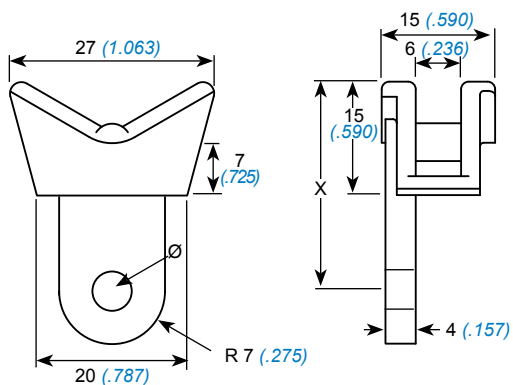
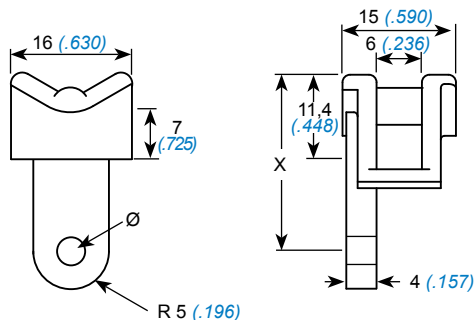

(1) Ref. Amphenol Air LB
(2) Ref. NSA → AIRBUS

SINGLE

Ø Câblage Ø Wiring	Ref.	Référence Part Number	Ø		X		Masse Weight
			mm	inch	mm	inch	g

Ø Câblage Ø Wiring	Ref.	Référence Part Number	Ø	X	Masse Weight		
0.08 to 0.59	2 à 15	(1) 003261 111 59	3,3	.129	19,5	.767	1,8
		(2) ASNE 0675A01			25	.984	2
		(1) 003261 109 59	5,2	.204	19,5	.767	1,8
		(2) ASNE 0675A02			25	.984	2
		(1) 003261 131 59	5,5	.216	19,5	.767	1,8
		(2) ASNE 0675A01A			25	.984	2
		(1) 003261 129 59	5,5	.216	19,5	.767	1,8
		(2) ASNE 0675A02A			25	.984	2
		(1) 003261 121 59	5,5	.216	19,5	.767	1,8
		(1) 003261 119 59			25	.984	2

Ø Câblage Ø Wiring	Ref.	Référence Part Number	Ø	X	Masse Weight		
0.08 to 1.18	2 à 30	(1) 003261 210 59	3,3	.129	22	.866	3
		(2) ASNE 0675 B01			28	1.102	3,3
		(1) 003261 110 59	5,2	.204	22	.866	3
		(2) ASNE 0675 B02			28	1.102	3,3
		(1) 003261 230 59	5,5	.216	22	.866	3
		(2) ASNE 0675B01A			28	1.102	3,3
		(1) 003261 130 59	5,5	.216	22	.866	3
		(2) ASNE 0675B02A			28	1.102	3,3
		(1) 003261 220 59	5,5	.216	22	.866	3
		(1) 003261 120 59			28	1.102	3,3

(1) Amphenol Air LB P/N
(2) NSA P/N → AIRBUS

SUPPORTS POUR APPLICATIONS SPECIFIQUES CABLE SUPPORTS FOR SPECIFIC APPLICATIONS



SUPPORT COUDE

ANGLED SUPPORT



Ø Câblage Ø Wiring	Mini-maxi	Ref.	Référence Part Number	Ø		Masse Weight
				mm	inch	g
0.08 to 0.59	2 à 15	(1)	ALBCBS 307 59	3,277	0.129	3,63

SUPPORT RENFORCE

HEAVY DUTY SUPPORT

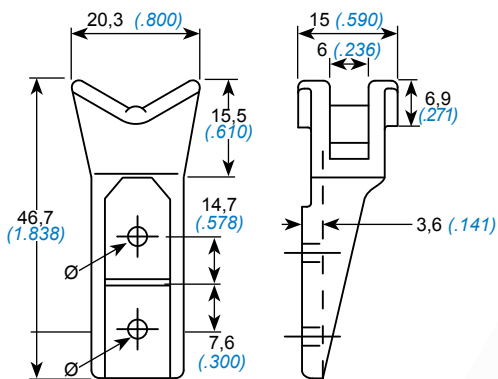

0.08 to 0.59	2 à 15	(1)	ALBCBS 308 59	3,277	0.129	8,17
--------------------	--------------	-----	---------------	-------	-------	------



SUPPORTS A PINCE

Ces supports de câbles à pince sont adaptés à des profilés métalliques.

- ① Support métallique plié
- ② Support métallique profilé

Toutes autres adaptations, consulter **Amphenol Air LB**.

CLAMPING SUPPORTS

These supports have been designed to be mounted onto metallic rails.

- ① Angled support
- ② Straight support

Other application, please consult **Amphenol Air LB**.

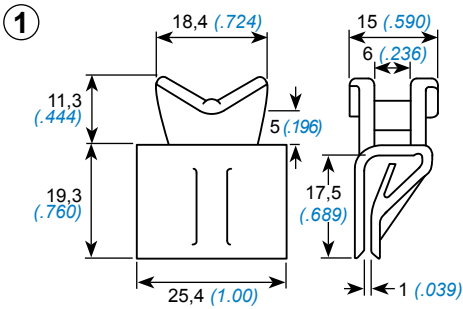
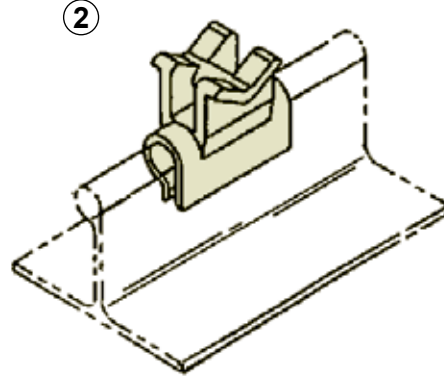
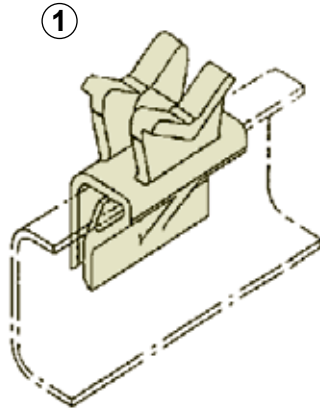

Ø Câblage Ø Wiring		Ref.	Référence Part Number	Masse Weight
Mini-maxi				g
inch	mm			
0.08 to 0.59	2 à 15	(1)	ALBCBS 310 59-01	3,4

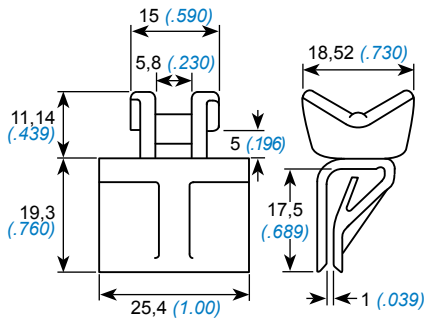

0.08 to 0.59	2 à 15	(1)	ALBCBS 310 59-02	3,4
--------------	--------	-----	------------------	-----

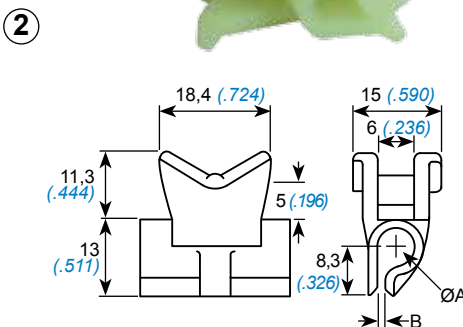

Ø Câblage Ø Wiring		Référence Part Number	Couleur Color	Ø A		B		Masse Weight
Mini-maxi				mm	inch	mm	inch	g
inch	mm							
0.08 to 0.59	2 à 15	ALBCBS 304 59-01	Vert Green	5,08	0.200	5,2	0.2	2,86
		ALBCBS 304 59-02	Blanc White	6,35	0.250	3,3	0.13	2,99
		ALBCBS 304 59-07	Gris Grey	7,11	0.280	3,3	0.13	3,44

SUPPORTS EN LIGNE

HARNESS TIEDOWN STRIP



Référence Part Number	Longueur A Length A		Largeur Width		Poids maxi. Maxi. weight g	Nombre d'attache Fixing points
	inch	mm	mm	inch		
ALBCBS 303 59-1	1.30	33,02	14,605	0.575	1,08	1
ALBCBS 303 59-3	2.30	58,42			1,86	2
ALBCBS 303 59-5	3.30	83,82			2,63	3
ALBCBS 303 59-7	4.30	109,22			3,90	4
ALBCBS 303 59-9	5.30	134,62			4,17	5
ALBCBS 303 59-11	6.30	160,02			4,99	6
ALBCBS 303 59-13	7.30	185,42			5,80	7
ALBCBS 303 59-15	8.30	210,82			6,58	8
ALBCBS 303 59-17	9.30	236,22			7,39	9
ALBCBS 303 59-19	10.30	261,62			8,16	10
ALBCBS 303 59-21	11.30	287,02			8,98	11
ALBCBS 303 59-23	12.30	312,42			9,80	12

SUPPORTS POUR HARNAIS DE CABLES

HARNESS SUPPORTS



SIMPLE

8 - 7 - 6 - 5 - 4 attaches (a)

SINGLE

8 - 7 - 6 - 5 - 4 fixing points (a)

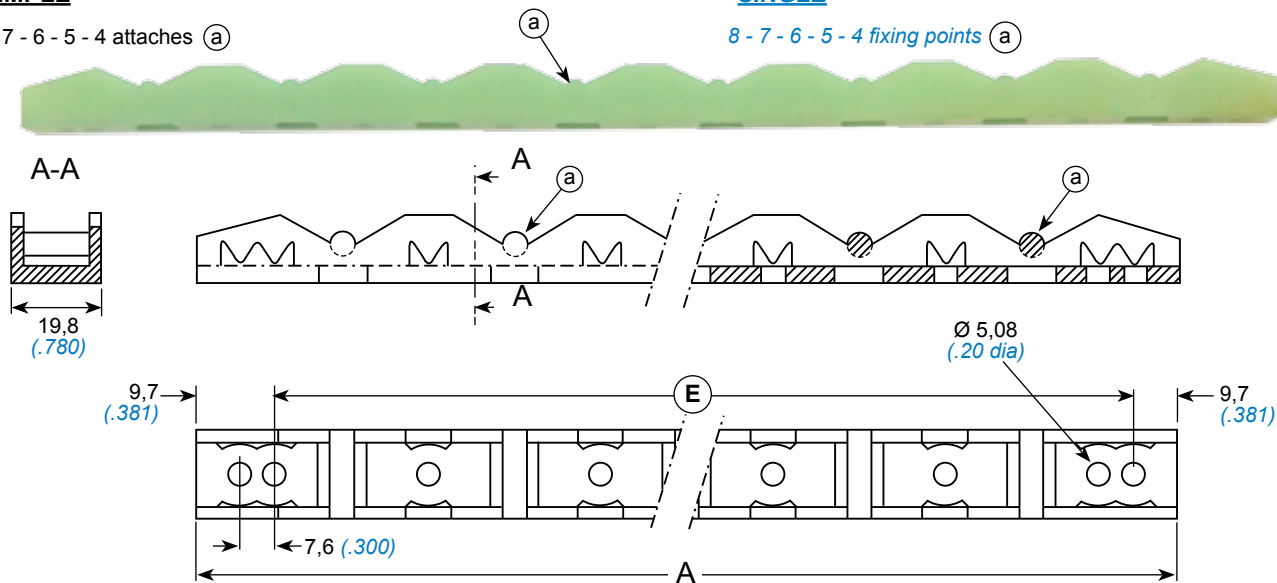

Référence Part Number	Longueur A A Length		Poids maximum Maximum weight	E Fixation Fixing		a Nombre d'attache Fixing points
	mm	inch		mm	inch	
ALBCBS 020 59-11	331,5	13.05	72,6	294,4	11.59	8
ALBCBS 020 59-13	293,4	11.55	63,5	256,3	10.09	7
ALBCBS 020 59-15	255,3	10.05	54,4	218,2	8.59	6
ALBCBS 020 59-17	217,2	8.55	45,4	180,1	7.09	5
ALBCBS 020 59-19	179,1	7.05	36,3	142,0	5.59	4

DOUBLE

15 - 13 - 11 - 9 - 7 attaches (a)

DOUBLE

15 - 13 - 11 - 9 - 7 fixing points (a)

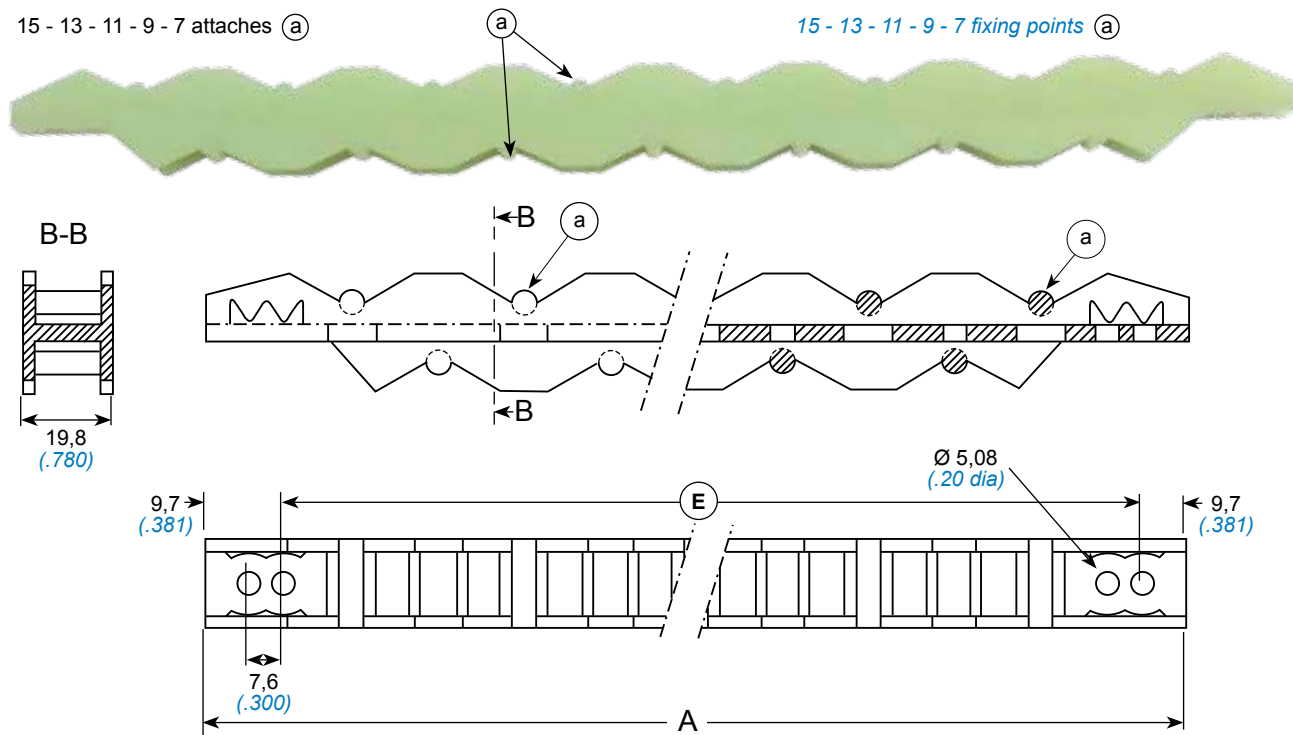

Référence Part Number	Longueur A A Length		Poids maximum Maximum weight	E Fixation Fixing		a Nombre d'attache Fixing points
	mm	inch		mm	inch	
ALBCBS 030 59-21	331,5	13.05	59,0	294,4	11.59	15
ALBCBS 030 59-23	293,4	11.55	49,9	256,3	10.09	13
ALBCBS 030 59-25	255,3	10.05	45,4	218,2	8.59	11
ALBCBS 030 59-27	217,2	8.55	36,3	180,1	7.09	9
ALBCBS 030 59-29	179,1	7.05	27,3	142,0	5.59	7



HAT SUPPORTS POUR HARNAIS DE CABLES

HAT SUPPORTS FOR CABLE ASSEMBLIES

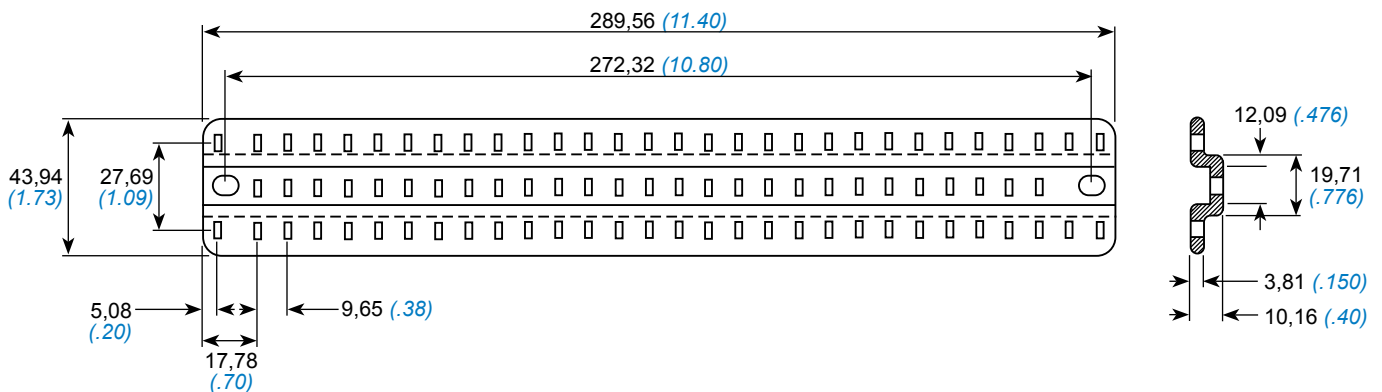

Référence Part Number	Longueur (± 1 mm) Length (± .040 inch)		Masse Weight g
	mm	inch	
ALBCBS 312 59-01	226,1	8.90	45,8
ALBCBS 312 59-02	232,4	9.15	47,1
ALBCBS 312 59-03	251,5	9.90	50,9
ALBCBS 312 59-04	137,2	5.40	27,8
ALBCBS 312 59-05	213,4	8.40	43,2
ALBCBS 312 59-06	242,1	9.53	49,0
ALBCBS 312 59-07	203,2	8.00	41,2
ALBCBS 312 59-08	194,3	7.65	39,4
ALBCBS 312 59-09	175,3	6.90	35,5
ALBCBS 312 59-10	154,9	6.10	31,4
ALBCBS 312 59-11	327,6	12.90	66,4
ALBCBS 312 59-12	205,7	8.10	41,7
ALBCBS 312 59-13	195,6	7.70	39,6

Référence Part Number	Longueur (± 1 mm) Length (± .040 inch)		Masse Weight g
	mm	inch	
ALBCBS 312 59-14	324,6	12.78	65,7
ALBCBS 312 59-15	289,5	11.40	58,6
ALBCBS 312 59-16	175,3	6.90	35,5
ALBCBS 312 59-17	115,3	4.54	23,4
ALBCBS 312 59-18	213,3	8.40	43,2
ALBCBS 312 59-19	182,6	7.19	37,0
ALBCBS 312 59-21	264,2	10.40	53,5
ALBCBS 312 59-23	287,0	11.30	58,1
ALBCBS 312 59-25	187,4	7.38	38,0
ALBCBS 312 59-27	157,5	6.20	31,9
ALBCBS 312 59-29	238,0	9.37	48,2
ALBCBS 312 59-31	205,7	8.10	41,7
ALBCBS 312 59-35	162,5	6.40	32,9



SEPARATEUR - ABS1144

ABS1144 - SEPARATOR



Ils définissent la distance séparant deux torons de câbles parallèles ou croisés, et sont disponibles en 9 versions.

Les séparateurs sont qualifiés suivant la norme Airbus ABS1144.

They maintain clearance between two parallel or crossing cable harnesses, with 9 different versions available.

They are qualified to Airbus standard ABS1144.



Référence Air LB <i>Air LB P/N</i>	Référence Airbus <i>Airbus P/N</i>	Nombre de composants / <i>number of parts</i>					Ø câble acceptable <i>Acceptable cable</i>		L		Masse <i>Weight</i> (+/- 10%)
		Tête 1 / <i>Head 1</i>	Tête 2 / <i>Head 2</i>	Tube 1	Tube 2	Tube 3	mm	<i>inch</i>	mm	<i>inch</i>	g
3308 8301 000	ABS1144A25A	2	-	1	-	-	0 à 16	<i>0 to 0.63</i>	25	<i>0.98</i>	4,65
3308 8302 000	ABS1144A50A	2	-	-	1	-	0 à 16	<i>0 to 0.63</i>	50	<i>1.97</i>	6,33
3308 8303 000	ABS1144A75A	2	-	-	-	1	0 à 16	<i>0 to 0.63</i>	75	<i>2.95</i>	7,81
3308 8304 000	ABS1144B25A	-	2	1	-	-	16 à 45	<i>0.63 to 1.77</i>	25	<i>0.98</i>	6,96
3308 8305 000	ABS1144B50A	-	2	-	1	-	16 à 45	<i>0.63 to 1.77</i>	50	<i>1.97</i>	8,63
3308 8306 000	ABS1144B75A	-	2	-	-	1	16 à 45	<i>0.63 to 1.77</i>	75	<i>2.95</i>	10,11
3308 8307 000	ABS1144C25A	1	1	1	-	-	0 à 16 & 16 à 45	<i>0 to 0.63 & 0.63 to 1.77</i>	25	<i>0.98</i>	5,81
3308 8308 000	ABS1144C50A	1	1	-	1	-	0 à 16 & 16 à 45	<i>0 to 0.63 & 0.63 to 1.77</i>	50	<i>1.97</i>	7,48
3308 8309 000	ABS1144C75A	1	1	-	-	1	0 à 16 & 16 à 45	<i>0 to 0.63 & 0.63 to 1.77</i>	75	<i>2.95</i>	8,96



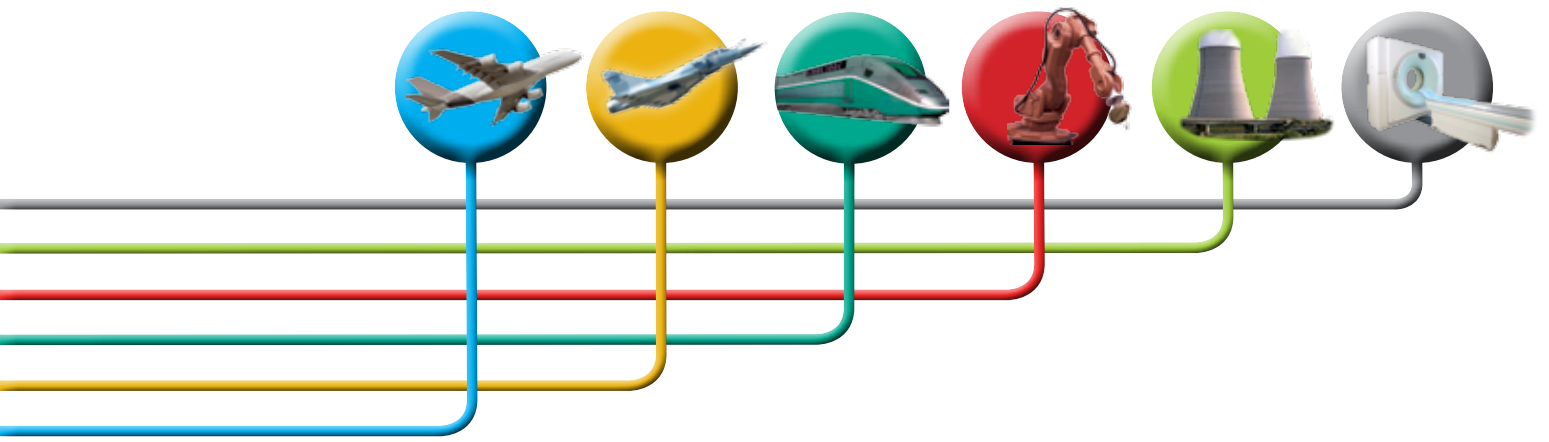

COLLIERS DE CHEMINEMENT série P et OMEGA



CABLE CLAMPS
P and OMEGA series

Edition 01/13

Amphenol Air LB

SYSTEMES DE CONNEXIONS ELECTRIQUES ET ELECTRONIQUES
ELECTRIC AND ELECTRONIC CONNECTION SYSTEMS

PRESENTATION PRESENTATION



AVANTAGES

- Protection des torons de câbles aux vibrations par élastomère surmoulé
- Matériaux utilisés non-corrosifs et non-conducteurs
- Marquage individuel pour reconnaissance facile et rapide

DISPOSITION GENERALE

Verrouillage et fixation sur structure par vis standard 10-32 (non fournie)

Colliers de cheminement disponibles en 17 versions différentes, pour des sections de câbles de 1,52 à 41,91mm de diamètre.

Application pour tous secteurs aéronautiques et industriels.

Fixation sur structure des ABS 1695

LÉGENDE :

- ① Collier de cheminement
- ② Protection élastomère
- ③ Structure



- ① Collier ouvert avec système de maintien en position ouverte
- ② Mise en place du toron de câble ou du tuyau
- ③ Collier fermé avec système de maintien en position fermée
- ④ Verrouillage et fixation sur structure par vis

ADVANTAGES

- Protection of electrical bundle from vibrations by over molded elastomer
- Non-corrosive and non-conductive materials
- Individual marking for easy and fast indentification

GENERAL DESIGN

Locking and fixation of cable clamps by standard 10-32 screws (no supplied).

LDG P-clamps are available in 17 different sizes and compatible with cables between .06 to 1.65 inch diameter.

Application in all industrials and aviation areas.

ABS 1695 panel fixing

CAPTION :

- ① Cable clamp
- ② Elastomer protection
- ③ Panel

- ① A locking feature keeps clamp open
- ② Wire bundle or tubing is inserted
- ③ Second locking feature keeps clamp closed
- ④ Screw inserted to complete installation

Série LDG
LDG series



Série OMEGA
OMEGA series



Série P
P series



COLLIER DE CHEMINEMENT - Série LDG P

LDG P series - CABLE CLAMPS



CARACTERISTIQUES

- Matière : Thermoplastique noir suivant MIL-P-46183
- Protection élastomère : Silicone vert clair

TECHNICAL DATA

- Cable clamp : Black thermoplastic per MIL-P-46183
- Elastomer protection : Light green silicone rubber

PERFORMANCES

- Température d'utilisation : -55°C à +135°C

PERFORMANCES

- Operating temperature : -55°C to +135°C

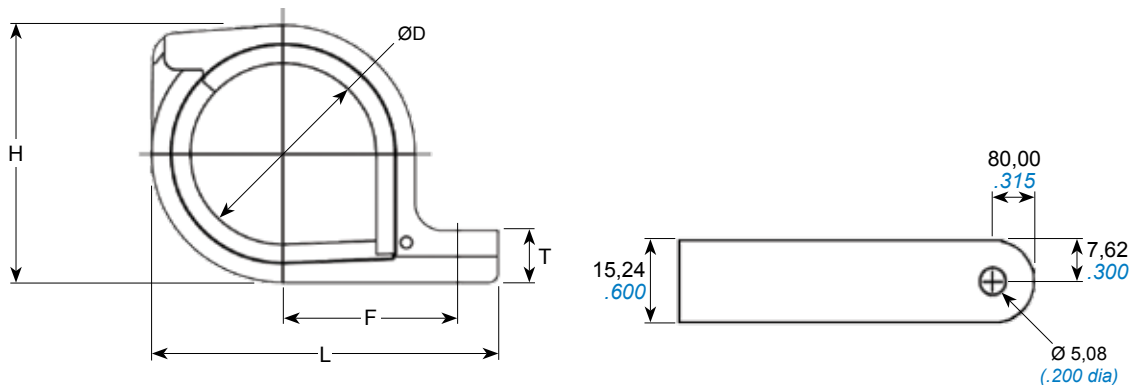

Référence Part Number	N° Taille Size N°	Ø D		L Longueur Lenght		H Hauteur Height		T Epaisseur Thickness		Masse Weight	
		mm	inch	mm	inch	mm	inch	mm	inch	g	10 ⁻³ lbs
PCL400100	100	0,76	.030	29,90	1.18	16,20	.64	4,60	.18	4,30	9.48
PCL400101	101	3,18	.125	29,90	1.18	16,20	.64	4,60	.18	4,08	9
PCL400102	102	5,56	.219	32,20	1.27	18,00	.71	4,60	.18	4,54	10
PCL400103	103	7,95	.313	35,90	1.41	20,60	.81	6,10	.24	6,35	14
PCL400104	104	10,34	.407	38,30	1.51	22,50	.88	6,10	.24	6,80	15
PCL400105	105	12,73	.501	40,70	1.60	24,40	.96	6,10	.24	7,71	17
PCL400106	106	15,09	.594	43,20	1.70	26,80	1.05	6,10	.24	8,16	18
PCL400107	107	17,50	.689	46,70	1.84	30,50	1.20	7,60	.30	10,89	24
PCL400108	108	19,86	.782	49,10	1.93	33,50	1.32	7,60	.30	12,25	27
PCL400109	109	22,25	.876	51,50	2.03	35,30	1.39	7,60	.30	12,70	28
PCL400110	110	24,61	.969	53,80	2.12	37,60	1.48	7,60	.30	13,61	30
PCL400111	111	27,00	1.063	57,50	2.26	41,20	1.62	9,10	.36	16,78	37
PCL400112	112	29,39	1.157	59,90	2.36	44,70	1.76	9,10	.36	18,14	40
PCL400113	113	31,78	1.251	62,30	2.45	46,30	1.82	9,10	.36	19,05	42
PCL400114	114	34,14	1.344	65,50	2.58	49,10	1.93	10,00	.40	21,32	47
PCL400115	115	36,53	1.438	68,30	2.69	52,00	2.05	10,70	.42	24,04	53
PCL400116	116	38,91	1.532	70,60	2.78	54,30	2.14	10,70	.42	26,04	57.4



COLLIERS DE CHEMINEMENT - Série P

P series - CABLE CLAMPS



CARACTERISTIQUES

- Matière : Thermoplastique suivant MIL-P-46183
- Protection élastomère : Silicone suivant ASTM-D-200

TECHNICAL DATA

- Cable clamp : Thermoplastic per MIL-P-46183
- Elastomer protection : Silicone Rubber per ASTM-D-200

PERFORMANCES

- Température d'utilisation : -54°C à +107°C

PERFORMANCES

- Operating temperature : -54°C to +107°C

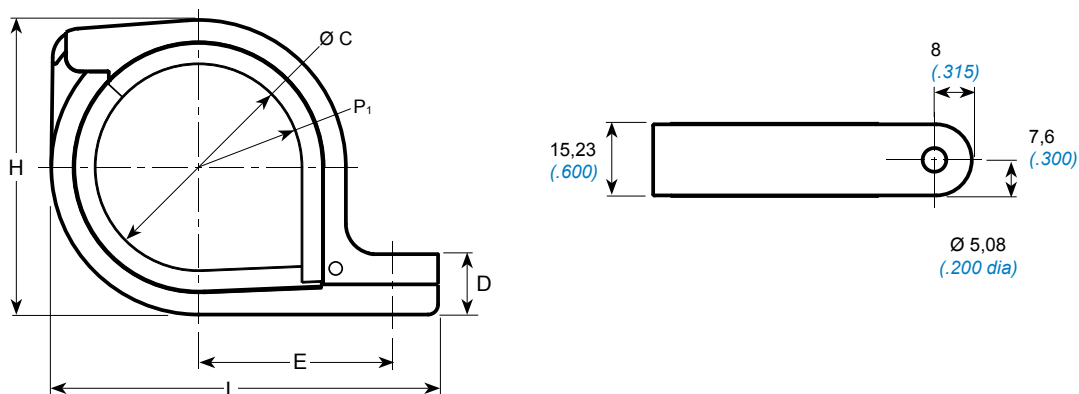

Référence Part Number	Charge du faisceau Wire Bundle Load		Ø C		E Entraxe Centre to centre		L Longueur Lenght		H Hauteur Height		D Epaisseur Thickness		Masse Weight	
	N (P _i)	Pounds Force (P _i)	mm	inch	mm	inch	mm	inch	mm	inch	mm	inch	g	10 ⁻³ lbs
PCL150101	111	25	3,05	0.12	14,98	0.59	29,97	1.18	16,26	0.64	4,57	0.18	4	9
PCL150102	133	30	5,59	0.22	16,26	0.64	32,26	1.27	18,03	0.71	4,57	0.18	4,9	11
PCL150103	155	35	7,87	0.31	18,03	0.71	35,81	1.41	20,83	0.82	6,10	0.24	6,8	15
PCL150104	177	40	10,41	0.41	19,30	0.76	38,35	1.51	22,35	0.88	6,10	0.24	7,7	17
PCL150105	222	50	12,70	0.50	20,57	0.81	40,64	1.60	23,38	0.96	6,10	0.24	8,6	19
PCL150106	244	55	14,98	0.59	21,59	0.85	42,93	1.69	26,67	1.05	6,10	0.24	9,5	21
PCL150107	289	65	17,52	0.69	23,62	0.93	46,74	1.84	30,48	1.20	7,62	0.30	11,8	26
PCL150108	333	75	19,81	0.78	24,64	0.97	49,02	1.93	33,53	1.32	7,62	0.30	13	29
PCL150109	280	63	22,35	0.88	25,91	1.02	51,56	2.03	35,31	1.39	7,62	0.30	14	31
PCL150110	324	73	24,64	0.97	27,18	1.07	53,85	2.12	37,59	1.48	7,62	0.30	15	33
PCL150111	355	80	26,92	1.06	28,96	1.14	57,40	2.26	41,15	1.62	9,14	0.36	18	40
PCL150112	400	90	29,46	1.16	29,97	1.18	59,94	2.36	44,45	1.75	9,14	0.36	20	44
PCL150113	462	104	31,75	1.25	31,24	1.23	62,23	2.45	46,23	1.82	9,14	0.36	21	46
PCL150114	542	118	34,04	1.34	32,77	1.29	65,28	2.57	49,02	1.93	10,16	0.40	23,5	52
PCL150115	556	125	36,58	1.44	34,29	1.35	68,33	2.69	52,07	2.05	10,67	0.42	25,8	57



COLLIER DE CHEMINEMENT - Série OMEGA

OMEGA series - CABLE CLAMPS



CARACTERISTIQUES

- Matière : Thermoplastique
- Protection élastomère : Silicone

TECHNICAL DATA

- Cable clamp : Thermoplastic
- Elastomer protection : Silicone rubber

PERFORMANCES

- Température d'utilisation : -54°C à +107°C

PERFORMANCES

- Operating temperature : -54°C to +107°C

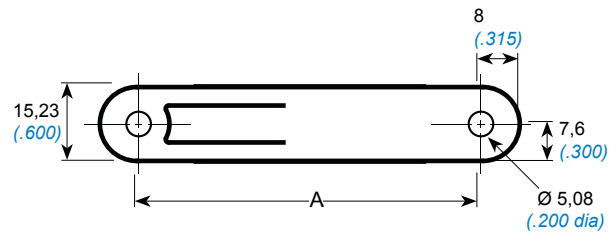
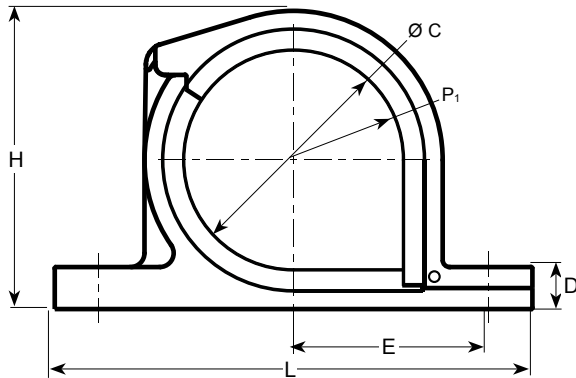

Référence Part Number	Charge du faisceau Wire Bundle Load		Ø C		L Longueur Length		E Entraxe Centre to centre		H Hauteur Height		A Entraxe Centre to centre		D Epaisseur Thickness		Masse Weight	
	N (P ₁)	Pounds Force (P ₁)	mm	inch	mm	inch	mm	Inch	mm	Inch	mm	Inch	mm	Inch	g	10 ⁻³ lbs
PCL250008	195	44	11,43	0.45	55,63	2.19	19,81	0.78	23,11	0.91	39,62	1.56	5,08	0.20	9	20
PCL250009	217	49	12,95	0.51	57,15	2.25	20,57	0.81	24,64	0.97	41,15	1.62	5,08	0.20	9,5	21
PCL250010	355	80	14,48	0.57	58,67	2.31	21,34	0.84	26,16	1.03	42,67	1.68	5,08	0.20	10	22
PCL250011	262	59	16,00	0.63	61,47	2.42	22,61	0.89	28,96	1.14	45,47	1.79	6,35	0.25	13	29
PCL250012	444	100	17,78	0.70	63,25	2.49	23,62	0.93	30,73	1.21	47,24	1.86	6,35	0.25	13,6	30
PCL250013	346	78	19,56	0.77	65,02	2.56	24,38	0.96	32,51	1.28	49,02	1.93	6,35	0.25	14,5	32
PCL250014	262	59	21,08	0.83	66,55	2.62	25,40	1.00	34,04	1.34	50,55	1.99	6,35	0.25	14,9	33
PCL250015	284	64	22,60	0.89	68,07	2.68	26,16	1.03	35,56	1.40	52,07	2.05	6,35	0.25	15,4	34
PCL250016	1112	250	24,13	0.95	70,87	2.79	27,43	1.08	38,35	1.51	54,86	2.16	7,62	0.30	19	42
PCL250017	338	76	25,65	1.01	72,39	2.85	28,19	1.11	39,88	1.57	56,39	2.22	7,62	0.30	20	44
PCL250018	369	83	27,18	1.07	73,91	2.91	28,96	1.14	41,40	1.63	57,91	2.28	7,62	0.30	20,4	45
PCL250019	400	90	28,70	1.13	75,44	2.97	29,72	1.17	42,93	1.69	59,44	2.34	7,62	0.30	21,3	47
PCL250020	1423	320	30,48	1.20	77,98	3.07	30,99	1.22	45,47	1.79	61,98	2.44	8,38	0.33	24	53
PCL250021	462	104	32,00	1.26	78,74	3.10	31,50	1.24	46,23	1.82	62,74	2.47	7,62	0.30	22,6	50
PCL250022	493	111	33,78	1.33	80,52	3.17	32,26	1.27	48,00	1.89	64,52	2.54	7,62	0.30	23,5	52
PCL250023	538	121	35,31	1.39	82,04	3.23	33,02	1.30	49,53	1.95	66,04	2.60	7,62	0.30	24	53
PCL250024	756	170	36,83	1.45	83,57	3.29	33,78	1.33	51,05	2.01	67,56	2.66	7,62	0.30	24,5	54
PCL250025	756	170	38,35	1.51	85,09	3.35	34,54	1.36	52,58	2.07	69,08	2.72	7,62	0.30	25,4	56
PCL250026	756	170	39,88	1.57	86,61	3.41	35,31	1.39	54,10	2.13	70,61	2.78	7,62	0.30	25,8	57
PCL250032	889	200	49,53	1.95	97,03	3.82	40,64	1.60	64,52	2.54	81,03	3.19	8,38	0.33	33,1	73



REFERENTIEL GENERAL

GENERAL PART NUMBERING



Ref / PN AALBF	Ref / PN AIRBUS	Autres Refs / Other PN	Masse / Weight	Page
003251 150 59			2,2	41
003261 100 59	NSA 935504-01		2,2	41
003261 101 59	NSA 935504-03		3,7	41
003261 102 59	NSA 935504-02		2,2	41
003261 109 59		ASNE 0675A02	2	45
003261 110 59		ASNE 0675B02	3,3	45
003261 111 59		ASNE 0675A01	1,8	45
003261 113 59			2,2	42
003261 114 59			2,2	42
003261 115 59			1,7	44
003261 116 59			2,4	44
003261 119 59			2	45
003261 120 59			3,3	45
003261 121 59			1,8	45
003261 127 59			4,5	41
003261 129 59		ASNE 0675A02A	2	45
003261 130 59		ASNE 0675B02A	3,3	45
003261 131 59		ASNE 0675A01A	1,8	45
003261 151 59			3,7	41
003261 152 59			2,2	41
003261 163 59			2,2	42
003261 167 59			3,2	42
003261 168 59			3,2	42
003261 173 59			3	42
003261 200 59			2,2	41
003261 201 59	NSA 935504-04		3,7	41
003261 202 59			2,2	41
003261 203 59			4,2	42
003261 210 59		ASNE 0675B01	3	45
003261 220 59			3	45
003261 227 59			4,5	41
003261 230 59		ASNE 0675B01A	3	45
003261 250 59			2,2	41
003261 251 59			3,7	41
003261 252 59			2,2	41
003261 501 59		ASNE 0254-01	3,64	43
003261 502 59		ASNE 0255-01	4,92	43
003261 503 59		ASNE 0255-02	6,14	43
003261 511 59		ASNE 0254-01A	3,62	43
003261 512 59		ASNE 0255-01A	4,9	43
003261 513 59		ASNE 0255-02A	6,13	43
003261 515 59		ASNE 0255-03A	6,1	43
003262 101 00	ABS 1339 D01		2,1	13
003262 102 00	ABS 1339 D02		2,5	13
003262 103 00	ABS 1339 D03		3,2	13
003262 104 00	ABS 1339 D04		4,2	13
003262 105 00	ABS 1339 D05		5,3	13
003262 106 00	ABS 1339 D06		8,3	13
003262 107 00	ABS 1339 D07		11,5	13
003262 108 00	ABS 1339 D08		14,6	13
003262 111 00	ABS 1339 F01		2,1	13
003262 112 00	ABS 1339 F02		2,5	13
003262 113 00	ABS 1339 F03		3,2	13



Ref / PN AALBF	Ref / PN AIRBUS	Autres Refs / Other PN	Masse / Weight	Page
003262 114 00	ABS 1339 F04		4,0	13
003262 115 00	ABS 1339 F05		5,3	13
003262 116 00	ABS 1339 F06		8,3	13
003262 117 00	ABS 1339 F07		11,5	13
003262 118 00	ABS 1339 F08		14,6	13
3308 8003 000	ABS1144A75A		7,81	51
3308 8004 000	ABS1144B25A		6,96	51
3308 8005 000	ABS1144B50A		8,63	51
3308 8006 000	ABS1144B75A		10,11	51
3308 8007 000	ABS1144C25A		5,81	51
3308 8008 000	ABS1144C50A		7,48	51
3308 8009 000	ABS1144C75A		8,96	51
3308 8301 000	ABS1144A25A		4,65	51
3308 8302 000	ABS1144A50A		6,33	51
3540 0004 356	ABS 1424-5-7		9,2	17
3540 0005 356	ABS 1106 A31		0,49	9
3540 0030 356 SCS	ABS 1106 B40		1	9
3540 0031 313	ABS 1424-4-10		14	17
3540 0032 356	ABS 1694 A300		8,5	27
3540 0033 356	ABS 1694 A325		12	28
3540 0034 356	ABS 1694 A350		13,5	29
3540 0038 356	ABS 1694 A301		9,1	27
3540 0039 356	ABS 1694 A302		12,1	28
3540 0040 356	ABS 1694 A375		25	29
3540 0131 000	ABS 2225 A10-01		11,7	37
3540 0132 000	ABS 2225 A10-02		13,2	37
3540 0133 000	ABS 2225 A10-03		14,7	37
3540 0042 356 SCS	ABS 2225 A12-01		1,5	38
3540 8073 000	ABS 1695 A05-01		30	33
3540 8074 000	ABS 1695 A05-02		29	33
3540 8075 000	ABS 1695 A05-03		23	33
3540 8076 000	ABS 1695 A05-04		22	33
3540 8077 000	ABS 1695 A701		40	34
3540 8078 000	ABS 1688 AB01		119,3	22
3540 8079 000	ABS 1688 AB02		119,5	22
3540 8080 000	ABS 1688 AB03		119,7	22
3540 8081 000	ABS 1688 AC01		126,8	23
3540 8082 000	ABS 1688 AC02		127	23
3540 8083 000	ABS 1688 AC03		127,2	23
3540 8084 000	ABS 1688 AC04		127,4	23
3540 8085 000	ABS 1688 AC05		127,6	23
3540 8086 000	ABS 1688 AC06		127,8	23
3540 8087 000	ABS 1688 AC07		128	23
3540 8088 000	ABS 1688 AB04		119,9	22
3540 8089 000	ABS 1688 AB05		120,1	22
3540 8090 000	ABS 1688 AB06		120,3	22
3540 8091 000	ABS 1688 AD01		59,3	24
3540 8092 000	ABS 1688 AD02		59,4	24
3540 8093 000	ABS 1688 AD03		59,5	24
3540 8094 000	ABS 1688 AD04		59,6	24
3540 8095 000	ABS 1688 AD05		59,7	24
3540 8096 000	ABS 1688 AD06		59,8	24
3540 8097 000	ABS 1688 AD07		59,9	24
3540 8098 000	ABS 1688 AB07		120,5	22
3540 8099 000	ABS 1695 A601		21	33
3540 8100 000	ABS 1694 A400		26,7	30
3540 8101 000	ABS 1694 A401		29,4	30
3540 8201 000	ABS 2225 A09-01		11	38



Ref / PN AALBF	Ref / PN AIRBUS	Autres Refs / Other PN	Masse / Weight	Page
3540 8202 000	ABS 2225 A09-02		17	38
3540 8203 000	ABS 2225 A09-03		23	38
3540 8204 000	ABS 2225 A09-04		29	38
3540 8205 000	ABS 2225 A09-05		34	38
3540 8206 000	ABS 2225 A09-06		39	38
3540 8207 000	ABS 2225 A09-07		46	38
3540 8208 000	ABS 2225 A09-08		52	38
3540 8209 000	ABS 2225 A09-09		58	38
3540 8210 000	ABS 2225 A09-10		63	38
3540 8211 000	ABS 2225 A09-11		69	38
3540 8212 000	ABS 2225 A09-12		75	38
3540 8213 000	ABS 2225 A09-13		81	38
3540 8214 000	ABS 2225 A09-14		87	38
3540 8215 000	ABS 2225 A09-15		93	38
3540 8216 000	ABS 2225 A09-16		98	38
3540 8217 000	ABS 2225 A09-17		104	38
3540 8218 000	ABS 2225 A09-18		110	38
3540 8219 000	ABS 2225 A09-19		116	38
3540 8220 000	ABS 2225 A09-20		122	38
3540 8221 000	ABS 2225 A09-21		127	38
3540 8222 000	ABS 2225 A09-22		133	38
3540 8223 000	ABS 2225 A09-23		140	38
3540 8224 000	ABS 2225 A09-24		145	38
ALBCBS 001 05			3	41
ALBCBS 001 06			4,5	41
ALBCBS 020 59-11			72,6	49
ALBCBS 020 59-13			63,5	49
ALBCBS 020 59-15			54,4	49
ALBCBS 020 59-17			45,4	49
ALBCBS 020 59-19			36,3	49
ALBCBS 030 59-21			59	49
ALBCBS 030 59-23			49,9	49
ALBCBS 030 59-25			45,4	49
ALBCBS 030 59-27			36,3	49
ALBCBS 030 59-29			27,3	49
ALBCBS 303 59-1			1,08	48
ALBCBS 303 59-11			4,99	48
ALBCBS 303 59-13			5,8	48
ALBCBS 303 59-15			6,58	48
ALBCBS 303 59-17			7,39	48
ALBCBS 303 59-19			8,16	48
ALBCBS 303 59-21			8,98	48
ALBCBS 303 59-23			9,8	48
ALBCBS 303 59-3			1,86	48
ALBCBS 303 59-5			2,63	48
ALBCBS 303 59-7			3,9	48
ALBCBS 303 59-9			4,17	48
ALBCBS 304 59-01			2,86	47
ALBCBS 304 59-02			2,99	47
ALBCBS 304 59-07			3,44	47
ALBCBS 307 59			3,63	46
ALBCBS 308 59			8,17	46
ALBCBS 310 59-01			3,4	47
ALBCBS 310 59-02			3,4	47
ALBCBS 312 59-01			45,8	50
ALBCBS 312 59-02			47,1	50
ALBCBS 312 59-03			50,9	50
ALBCBS 312 59-04			27,8	50



Ref / PN AALBF	Ref / PN AIRBUS	Autres Refs / Other PN	Masse / Weight	Page
ALBCBS 312 59-05			43,2	50
ALBCBS 312 59-06			49	50
ALBCBS 312 59-07			41,2	50
ALBCBS 312 59-08			39,4	50
ALBCBS 312 59-09			35,5	50
ALBCBS 312 59-10			31,4	50
ALBCBS 312 59-11			66,4	50
ALBCBS 312 59-12			41,7	50
ALBCBS 312 59-13			39,6	50
ALBCBS 312 59-14			65,7	50
ALBCBS 312 59-15			58,6	50
ALBCBS 312 59-16			35,5	50
ALBCBS 312 59-17			23,4	50
ALBCBS 312 59-18			43,2	50
ALBCBS 312 59-19			37	50
ALBCBS 312 59-21			53,5	50
ALBCBS 312 59-23			58,1	50
ALBCBS 312 59-25			38	50
ALBCBS 312 59-27			31,9	50
ALBCBS 312 59-29			48,2	50
ALBCBS 312 59-31			41,7	50
ALBCBS 312 59-35			32,9	50
PCL150101			4	56
PCL150101			4	56
PCL150102			4,9	56
PCL150102			4,9	56
PCL150103			6,8	56
PCL150103			6,8	56
PCL150104			7,7	56
PCL150104			7,7	56
PCL150105			8,6	56
PCL150105			8,6	56
PCL150106			9,5	56
PCL150106			9,5	56
PCL150107			11,8	56
PCL150107			11,8	56
PCL150108			13	56
PCL150108			13	56
PCL150109			14	56
PCL150109			14	56
PCL150110			15	56
PCL150110			15	56
PCL150111			18	56
PCL150111			18	56
PCL150112			20	56
PCL150112			20	56
PCL150113			21	56
PCL150113			21	56
PCL150114			23,5	56
PCL150114			23,5	56
PCL150115			25,8	56
PCL150115			25,8	56
PCL250008			9	57
PCL250008			9	57
PCL250009			9,5	57
PCL250009			9,5	57
PCL250010			10	57
PCL250010			10	57



Ref / PN AALBF	Ref / PN AIRBUS	Autres Refs / Other PN	Masse / Weight	Page
PCL250011			13	57
PCL250011			13	57
PCL250012			13,6	57
PCL250012			13,6	57
PCL250013			14,5	57
PCL250013			14,5	57
PCL250014			14,9	57
PCL250014			14,9	57
PCL250015			15,4	57
PCL250015			15,4	57
PCL250016			19	57
PCL250016			19	57
PCL250017			20	57
PCL250017			20	57
PCL250018			20,4	57
PCL250018			20,4	57
PCL250019			21,3	57
PCL250019			21,3	57
PCL250020			24	57
PCL250020			24	57
PCL250021			22,6	57
PCL250021			22,6	57
PCL250022			23,5	57
PCL250022			23,5	57
PCL250023			24	57
PCL250023			24	57
PCL250024			24,5	57
PCL250024			24,5	57
PCL250025			25,4	57
PCL250025			25,4	57
PCL250026			25,8	57
PCL250026			25,8	57
PCL250032			33,1	57
PCL250032			33,1	57
PCL400100			4,3	55
PCL400101			4,08	55
PCL400102			4,54	55
PCL400103			6,35	55
PCL400104			6,8	55
PCL400105			7,71	55
PCL400106			8,16	55
PCL400107			10,89	55
PCL400108			12,25	55
PCL400109			12,75	55
PCL400110			13,61	55
PCL400111			16,78	55
PCL400112			18,14	55
PCL400113			19,05	55
PCL400114			21,32	55
PCL400115			24,04	55
PCL400116			26,04	55

Amphenol

Amphenol Air LB

Direction des Ventes / Sales office

Immeuble le Doublon - 11, Avenue Dubonnet
92407 COURBEVOIE Cedex - France

Tél. : (33) 01 49 05 30 00 - Fax : (33) 01 49 05 30 10
dircial@amphenol-airlb.fr

www.amphenol-airlb.fr

Service Commercial / Customer Service	Support Technique / Technical Support
Tél. : (33) 03 24 22 32 66 - Fax : (33) 03 24 22 38 72 service-client@amphenol-airlb.fr	Tél. : (33) 03 24 22 78 63 technical-support@amphenol-airlb.fr

Amphenol Air LB - Siège social, Finances, R&D
Head Office, Finances, R&D



29, Voie d'Yvois
08110 BLAGNY - FRANCE

Amphenol Air LB - Centre de Production
Production Center



10, Rue Champ Raymond
08110 CARIGNAN - FRANCE

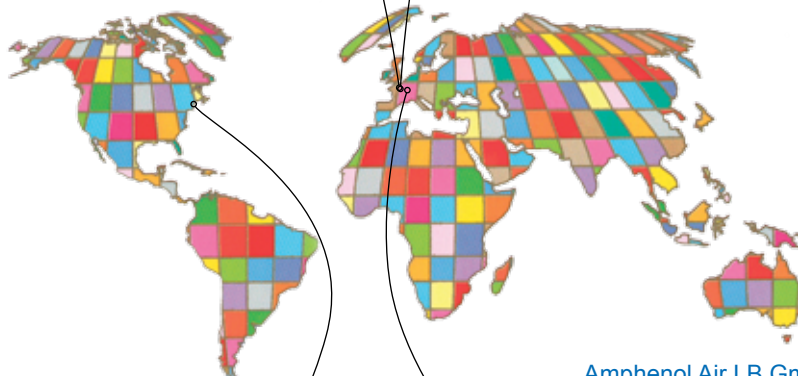

Amphenol Pcd



72 Cherry Hill Drive - Beverly, MA 01915 USA
Tel : (+1) 978 624.3400 - Fax: (+1) 978 927.1513
www.amphenolpcd.com
info@amphenolpcd.com

Amphenol Air LB GmbH



Am Kleinbahnhof 4 - D-66740 SAARLOUIS
Tél. : (49) 68 31 98 10 18 - Fax : (49) 68 31 98 10 30
www.amphenol-airlb.de
info@amphenol-airlb.de

Autres divisions Amphenol

More divisions on
www.amphenol.com

Ce document n'est pas contractuel. Les informations contenues dans ce catalogue sont susceptibles d'évolution.

Amphenol-Air LB se réserve le droit de procéder à des modifications sans préavis. Pour tout renseignement complémentaire, nous consulter.

This document is not a contractual document. The information included in this catalogue is subject to changes.

Amphenol-Air LB reserves the right to proceed with modifications without prior notice. For any additional information, do not hesitate to contact us.

Данный компонент на территории Российской Федерации

Вы можете приобрести в компании MosChip.

Для оперативного оформления запроса Вам необходимо перейти по данной ссылке:

<http://moschip.ru/get-element>

Вы можете разместить у нас заказ для любого Вашего проекта, будь то серийное производство или разработка единичного прибора.

В нашем ассортименте представлены ведущие мировые производители активных и пассивных электронных компонентов.

Нашей специализацией является поставка электронной компонентной базы двойного назначения, продукции таких производителей как XILINX, Intel (ex.ALTERA), Vicor, Microchip, Texas Instruments, Analog Devices, Mini-Circuits, Amphenol, Glenair.

Сотрудничество с глобальными дистрибьюторами электронных компонентов, предоставляет возможность заказывать и получать с международных складов практически любой перечень компонентов в оптимальные для Вас сроки.

На всех этапах разработки и производства наши партнеры могут получить квалифицированную поддержку опытных инженеров.

Система менеджмента качества компании отвечает требованиям в соответствии с ГОСТ Р ИСО 9001, ГОСТ РВ 0015-002 и ЭС РД 009

Офис по работе с юридическими лицами:

105318, г.Москва, ул.Щербаковская д.3, офис 1107, 1118, ДЦ «Щербаковский»

Телефон: +7 495 668-12-70 (многоканальный)

Факс: +7 495 668-12-70 (доб.304)

E-mail: info@moschip.ru

Skype отдела продаж:

moschip.ru

moschip.ru_4

moschip.ru_6

moschip.ru_9