



# Si5330x Data Sheet

---

## Ultra-Low Additive Jitter Fanout Clock Buffers with up to 10 Universal Outputs from Any-Format Input and Wide Frequency Range from 1 MHz to 725 MHz

The Si5330x family of Universal/Any-format fanout buffers is ideal for clock distribution (1 MHz minimum) and redundant clocking applications. These devices feature typical ultra-low jitter characteristics of 50 fs and operate over a wide frequency range. Built-in LDOs deliver high PSRR performance and reduce the need for external components, simplifying low-jitter clock distribution in noisy environments.

The Si5330x family is available in multiple configurations, with some versions offering a selectable input clock using a 2:1 input mux. Other features include independent (synchronous) output enable, glitchless switching, LOS monitor of input clocks, output clock division, and built-in format translation. These buffers can be paired with the Si534x clocks and jitter attenuators, the Si5332 clocks, and the Si5xx oscillators to deliver end-to-end clock tree performance.

### KEY FEATURES

---

- Ultra-low additive jitter: 50 fs rms
- Built-in LDOs for high PSRR performance
- Up to 10 outputs
- Any-format Inputs (LVPECL, Low-power LVPECL, LVDS, CML, HCSSL, LVCMOS)
- Wide frequency range
- Output Enable option
- Multiple configuration options
  - Dual Bank option
  - 2:1 Input Mux operation
- Synchronous output enable
- Loss of signal (LOS) monitors for loss of input clock
- Output clock division: /1, /2, /4
- RoHS compliant, Pb-free
- Temperature range: -40 to +85 °C

## 1. Ordering Guide

Table 1.1. Product Family Overview

Part Number	Description	Input MUX	Input	Output	Glitch-less Switch <sup>1</sup>	LOS Output	OE Option	Synchronous OE <sup>1</sup>	Clk Divider Option
Si53301-B-GM	6 output universal buffer with 2:1 input mux	Yes	2	6 Diff / 12 SE	Yes	Yes	Per Bank	Yes	Per Bank
Si53302-B-GM	10 output universal buffer with 2:1 input mux	Yes	2	10 Diff / 20 SE	Yes	Yes	Per Bank	Yes	Per Bank
Si53303-B-GM	Dual 1:5 universal buffer	No	2	5 Diff / 10 SE	No	No	Per Bank	Yes	Per Bank
Si53304-B-GM	6 output universal buffer with 2:1 input mux	Yes	2	6 Diff / 12 SE	Yes	No	Individual	Yes	No
Si53305-B-GM	10 output universal buffer with 2:1 input mux	Yes	2	10 Diff / 20 SE	Yes	No	Individual	Yes	No
Si53306-B-GM	4 output universal buffer, single input	No	1	4 Diff / 8 SE	No	No	Single	Yes	No
Si53307-B-GM	2 output universal buffer with 2:1 input mux	Yes	2	2 Diff / 4 SE	Yes	No	Single	Yes	No
Si53308-B-GM	Dual 1:3 universal buffer	No	2	3 Diff / 6 SE	No	Yes	Per Bank	Yes	Per Bank

**Note:**

- The synchronous features (Glitch-less switching and Synchronous OE) of the Si533xx family require a minimum input clock frequency of 1 MHz. If the selected input clock stops, pauses, or is gapped such that the 1 MHz minimum is not met for any time interval, then the output clock(s) will be disabled (turned off). Once the paused input clock restarts, the output clock may NOT start up immediately. Output start-up (turning back on) may be delayed for several input clock cycles until the internal synchronizer determines the input clock is once again valid.
- Click on the part number above to see a block diagram for each corresponding part number.

Table 1.2. Si5330x Ordering Guide

Part Number	Package	Pb-Free, ROHS-6	Temperature
Si53301-B-GM <sup>1</sup>	32-QFN	Yes	-40 to 85 °C
Si53302-B-GM <sup>1</sup>	44-QFN	Yes	-40 to 85 °C
Si53303-B-GM <sup>1</sup>	44-QFN	Yes	-40 to 85 °C
Si53304-B-GM <sup>1</sup>	32-QFN	Yes	-40 to 85 °C
Si53305-B-GM <sup>1</sup>	44-QFN	Yes	-40 to 85 °C
Si53306-B-GM <sup>1</sup>	16-QFN	Yes	-40 to 85 °C
Si53307-B-GM <sup>1</sup>	16-QFN	Yes	-40 to 85 °C
Si53308-B-GM <sup>1</sup>	32-QFN	Yes	-40 to 85 °C
Si53301/4-EVB	Evaluation Board	—	—

**Note:**

- Add an "R" at the end of the OPN to denote tape and reel ordering options.

# Table of Contents

<b>1. Ordering Guide</b>	<b>2</b>
<b>2. Functional Description</b>	<b>5</b>
2.1 Universal, Any-Format Input Termination	5
2.2 Internal Input Bias Resistors	8
2.3 Voltage Reference ( $V_{REF}$ )	9
2.4 Universal, Any-Format Output Buffer	9
2.5 Input Mux (Si53301/02/04/05/07 Only)	10
2.6 Glitchless Clock Input Switching	10
2.7 Synchronous Output Enable	10
2.8 Loss of Signal (LOS) Indicator	11
2.9 Flexible Output Divider	11
2.10 Power Supply ( $V_{DD}$ and $V_{DDOX}$ )	11
2.11 Output Clock Termination Options	12
2.12 LVCMOS Output Termination to Support 1.5 V and 1.2 V	14
2.13 AC Timing Waveforms	14
2.14 Typical Phase Noise Performance (Differential Input Clock)	15
2.15 Typical Phase Noise Performance (Single-Ended Input Clock)	17
2.16 Input Mux Noise Isolation	18
2.17 Power Supply Noise Rejection	18
<b>3. Electrical Specifications</b>	<b>19</b>
<b>4. Detailed Block Diagrams</b>	<b>28</b>
<b>5. Pin Descriptions</b>	<b>35</b>
5.1 Si53301 Pin Descriptions	35
5.2 Si53302 Pin Descriptions	38
5.3 Si53303 Pin Descriptions	41
5.4 Si53304 Pin Descriptions	44
5.5 Si53305 Pin Descriptions	47
5.6 Si53306 Pin Descriptions	51
5.7 Si53307 Pin Descriptions	53
5.8 Si53308 Pin Descriptions	55
<b>6. Package Outlines</b>	<b>58</b>
6.1 16-QFN Package Diagram	58
6.2 32-QFN Package Diagram	59
6.3 44-QFN Package Diagram	60
<b>7. Land Patterns</b>	<b>61</b>

- 7.1 16-QFN Land Pattern . . . . .61
- 7.2 32-QFN Land Pattern . . . . .62
- 7.3 44-QFN Land Pattern . . . . .63
- 8. Top Markings . . . . . 64**
- 8.1 Si53301/04/08 Top Markings . . . . .64
- 8.2 Si53302/03/05 Top Markings . . . . .65
- 8.3 Si53306/07 Top Markings . . . . .66
- 9. Revision History . . . . . 67**

## 2. Functional Description

The Si5330x family of low-jitter, low-skew, universal/any-format buffers accepts most common differential or LVCMOS input signals. These devices are available in multiple configurations customized for the end application (refer to [1. Ordering Guide](#) for more details on configurations).

### 2.1 Universal, Any-Format Input Termination

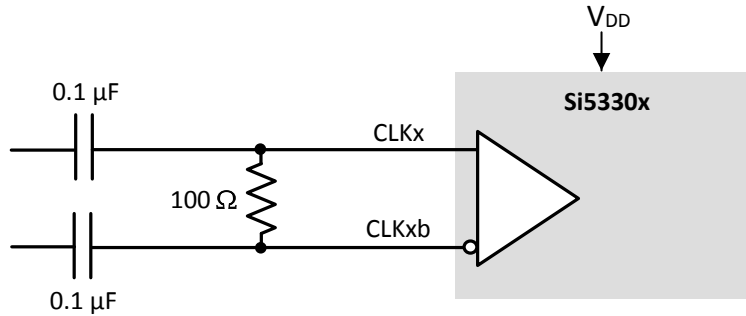
The universal input stage enables simple interfacing to a wide variety of clock formats, including LVPECL, low-power LVPECL, LVCMOS, LVDS, HCSL, and CML. The simplified tables below summarize the various ac- and dc-coupling options supported by the device. For the best high-speed performance, the use of differential formats is recommended. For both single-ended and differential input clocks, the fastest possible slew rate is recommended since low slew rates can increase the noise floor and degrade jitter performance. Though not required, a minimum slew rate of 0.75 V/ns is recommended for differential formats and 1.0 V/ns for single-ended formats. See [AN766: Understanding and Optimizing Clock Buffer's Additive Jitter Performance](#) for more information.

**Table 2.1. AC-Coupled Clock Input Options**

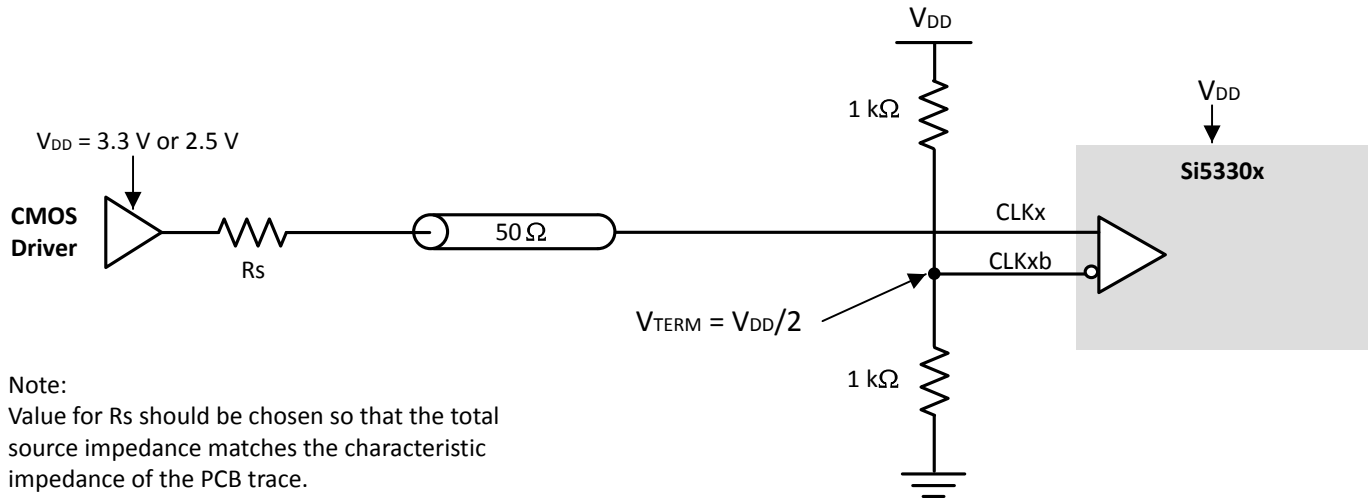
Clock Format	1.8 V	2.5/3.3 V
LVPECL/Low-power LVPECL	N/A	Yes
LVCMOS	No	Yes
LVDS	Yes	Yes
HCSL	No	Yes
CML	Yes	Yes

**Table 2.2. DC-Coupled Clock Input Options**

Clock Format	1.8 V	2.5/3.3 V
LVPECL/Low-power LVPECL	N/A	Yes
LVCMOS	No	Yes
LVDS	No	Yes
HCSL	No	Yes
CML	No	No

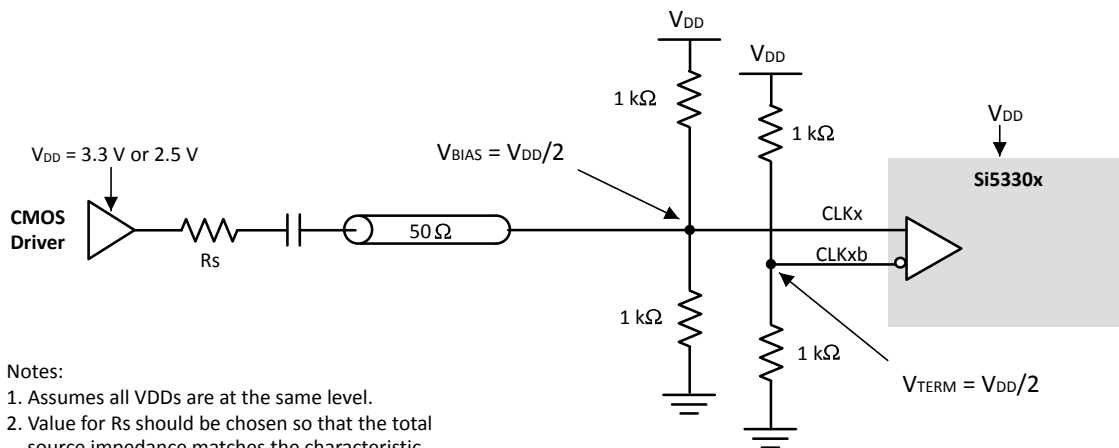


**Figure 2.1. Differential (HCSL, LVPECL, Low-Power LVPECL, LVDS, CML) AC-Coupled Input Termination**



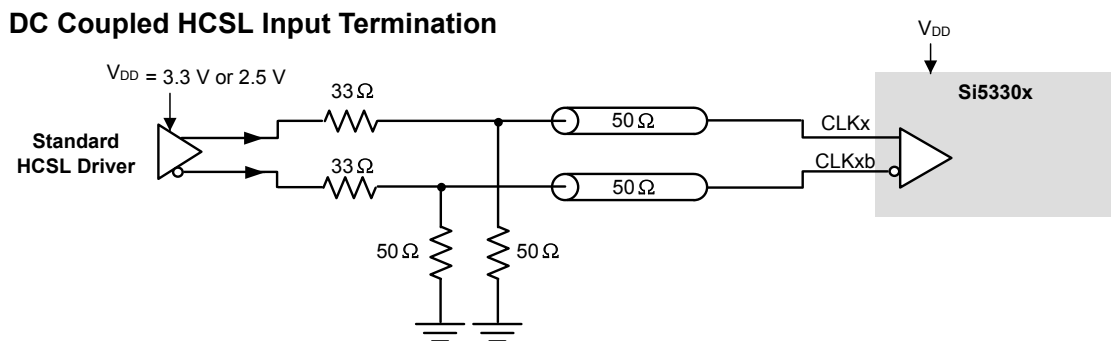
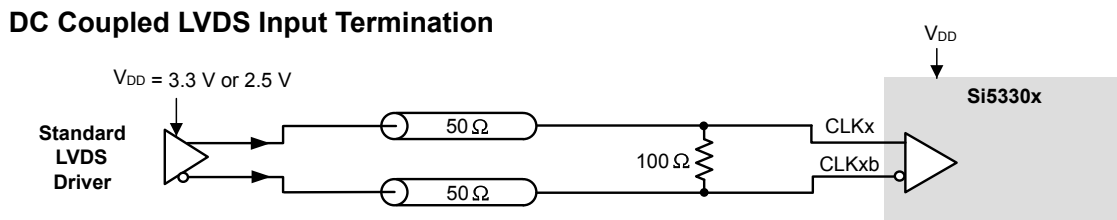
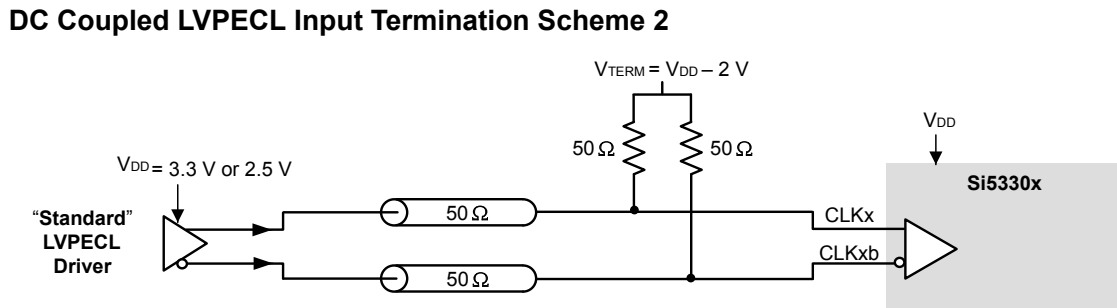
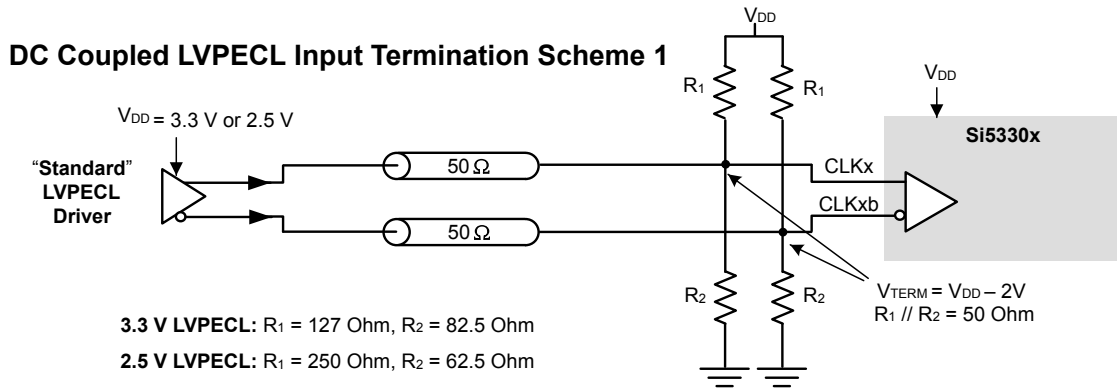
Note:  
 Value for  $R_s$  should be chosen so that the total source impedance matches the characteristic impedance of the PCB trace.

**Figure 2.2. DC-Coupled, Single-Ended (LVCMOS) Input Termination**



Notes:  
 1. Assumes all VDDs are at the same level.  
 2. Value for  $R_s$  should be chosen so that the total source impedance matches the characteristic impedance of the PCB trace.

**Figure 2.3. AC-Coupled, Single-Ended (LVCMOS) Input Termination**



Note: 33 Ohm series termination is optional depending on the location of the receiver.

**Figure 2.4. Differential DC-Coupled Input Terminations**

Table 2.3. AC/DC-Coupled Clock Input Requirements for Glitchless, Non-Continuous Clocks<sup>1, 2, 3</sup>

Clock Input Type	Input Clock Driver Stop State		
	Low	High	High-Z
DC-Coupled	Yes	Yes	No
AC-Coupled	Yes	No	No

**Note:**

1. "Non-continuous clocks" means any clock that can be stopped, disabled, or gapped.
2. "Yes" means this configuration is supported.
3. "No" indicates that the configuration is not supported. Operating under a "No" condition can result in erroneous clock outputs and/or erroneous LOS indications. Operating the device in unsupported configurations is not recommended.

**2.2 Internal Input Bias Resistors**

Internal bias resistors ensure a differential output low condition in the event that the clock inputs are not connected. The clock input should not be actively driven when power is not applied to the device. The non-inverting input is biased with a 18.75 k $\Omega$  pull-down to GND and a 75 k $\Omega$  pull-up to V<sub>DD</sub>. The inverting input is biased with a 75 k $\Omega$  pull-up to V<sub>DD</sub>.

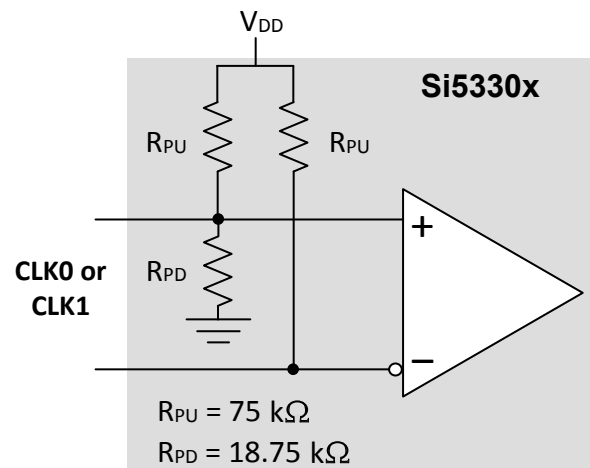


Figure 2.5. Internal Input Bias Resistors



## 2.3 Voltage Reference ( $V_{REF}$ )

The  $V_{REF}$  pin can be used to bias the input receiver, as shown in the figure below, when a single-ended input clock (such as LVCMOS) is used. Note that  $V_{REF} = V_{DD}/2$  and should be compatible with the  $V_{cm}$  rating of the single-ended input clock driving the CLK0 or CLK1 inputs. To optimize jitter and duty cycle performance, use the circuit in [Figure 2.3 AC-Coupled, Single-Ended \(LVCMOS\) Input Termination on page 6](#).  $V_{REF}$  pin should be left floating when differential clocks are used.

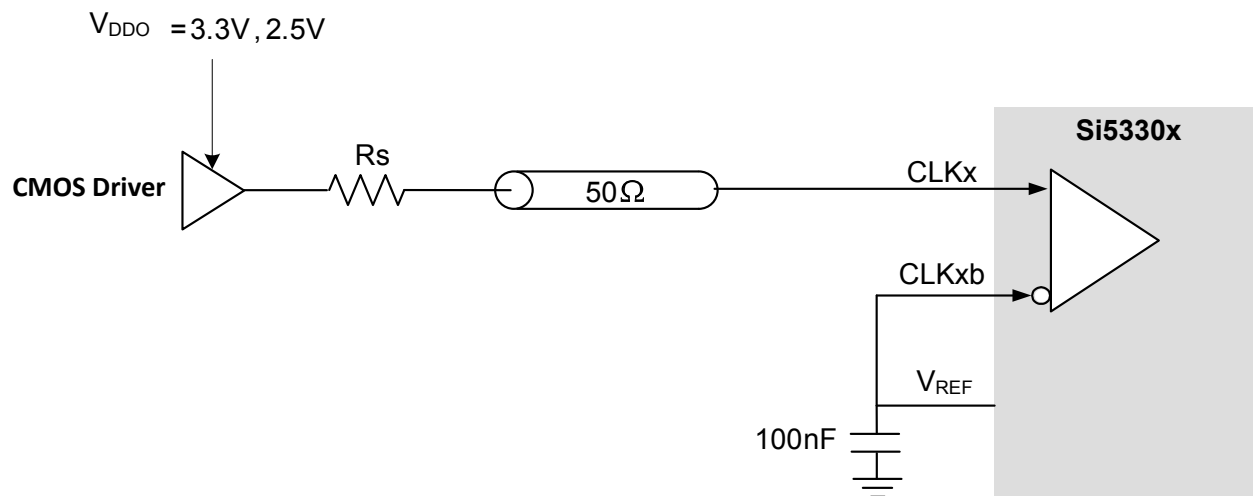


Figure 2.6. Using Voltage Reference with Single-Ended Input Clock

## 2.4 Universal, Any-Format Output Buffer

The highly flexible output drivers support a wide range of clock signal formats, including LVPECL, low power LVPECL, LVDS, CML, HCSL, and LVCMOS. SFOUTx[1] and SFOUTx[0] are 3-level inputs that can be pinstrapped to select the Bank A and Bank B clock signal formats independently. This feature enables the device to be used for format/level translation in addition to clock distribution, minimizing the number of unique buffer part numbers required in a typical application and simplifying design reuse. For EMI reduction applications, four LVCMOS drive strength options are available for each  $V_{DDO}$  setting.

Table 2.4. Output Signal Format Selection

SFOUTx[1]	SFOUTx[0]	VDDOX = 3.3 V	VDDOX = 2.5 V	VDDOX = 1.8 V
Open <sup>1</sup>	Open <sup>1</sup>	LVPECL	LVPECL	N/A
0	0	LVDS	LVDS	LVDS
0	1	LVCMOS, 24 mA drive	LVCMOS, 18 mA drive	LVCMOS, 12 mA drive
1	0	LVCMOS, 18 mA drive	LVCMOS, 12 mA drive	LVCMOS, 9 mA drive
1	1	LVCMOS, 12 mA drive	LVCMOS, 9 mA drive	LVCMOS, 6 mA drive
Open <sup>1</sup>	0	LVCMOS, 6 mA drive	LVCMOS, 4 mA drive	LVCMOS, 2 mA drive
Open <sup>1</sup>	1	LVPECL Low power	LVPECL Low power	N/A
0	Open <sup>1</sup>	CML	CML	CML
1	Open <sup>1</sup>	HCSL	HCSL	N/A

**Note:**

1. SFOUTx[1:0] are 3-level input pins. Tie low for “0” setting. Tie high for “1” setting. When left open, the pin is internally biased to  $V_{DD}/2$ .

## 2.5 Input Mux (Si53301/02/04/05/07 Only)

The Si53301/02/04/05/07 provide two clock inputs for applications that need to select between one of two clock sources. The CLK\_SEL pin selects the active clock input and has an internal pulldown resistor. The following table summarizes the input and output clock based on the input mux pin settings.

**Table 2.5. Input Mux Logic**

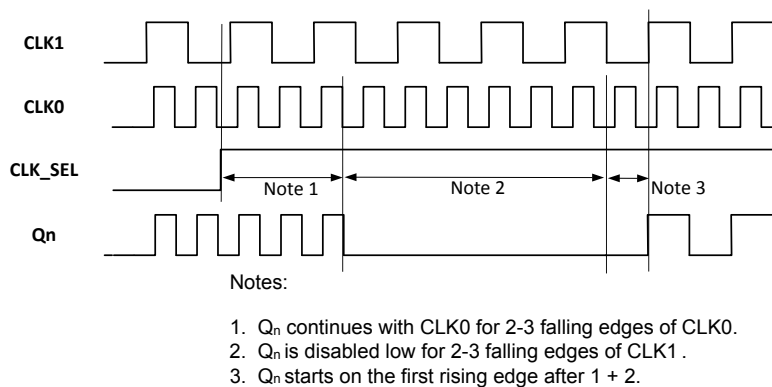
CLK_SEL	CLK0	CLK1	Q <sup>1</sup>	Q <sub>b</sub>
L	L	X	L	H
L	H	X	H	L
H	X	L	L	H
H	X	H	H	L

**Note:**

1. On the next negative transition of CLK0 or CLK1.

## 2.6 Glitchless Clock Input Switching

The Si53301/2/4/5/7 feature glitchless switching between two valid input clocks. The following figure illustrates that switching between input clocks does not generate runt pulses or glitches at the output.



**Figure 2.7. Glitchless Input Clock Switch**

The Si53301/2/4/5/7 support glitchless switching between clock inputs with a frequency variance up to 10x. When a switchover to a new clock is made, the output will disable low after two or three clock cycles of the previously selected input clock. The outputs will remain low for up to three clock cycles of the newly-selected clock, after which the outputs will start from the newly-selected input. If a switchover to an absent clock is made, the output will glitchlessly stop low and wait for edges of the newly-selected clock. A switchover from an absent clock to a live clock will also be glitchless. Note that the CLK\_SEL input should not be toggled faster than 1/250th the frequency of the slower input clock.

## 2.7 Synchronous Output Enable

The Si5330x features a synchronous output enable (disable) feature. The output enable pin is sampled and synchronized to the falling edge of the input clock. This feature prevents runt pulses from being generated when the outputs are enabled or disabled.

When OE is low, Q is held low and Q<sub>b</sub> is held high for differential output formats. For LVCMOS output format options, both Q and Q<sub>b</sub> are held low when OE is set low. The output enable pin has an internal pull-up that enables the outputs when left unconnected. See [Table 3.10 AC Characteristics on page 23](#) for output enable and output disable times.

## 2.8 Loss of Signal (LOS) Indicator

Si53301/2/8 feature a Loss of Signal (LOS) indicator. The LOS0 and LOS1 indicators are used to check for the presence of input clocks CLK0 and CLK1. The LOS0 and LOS1 pins must be checked prior to selecting the clock input or should be polled to check for the presence of the currently selected input clock. In the event that an input clock is not present, the associated LOSx pin will assume a logic high (LOSx = 1) state. When a clock is present at the associated input clock pin, the LOSx pin will assume a logic low (LOSx = 0) state.

## 2.9 Flexible Output Divider

The Si53301/02/03/08 provide optional clock division in addition to clock distribution. The divider setting for each bank of output clocks is selected via 3-level control pins as shown in the table below. Leaving the DIVx pins open will force a divider value of 1, which is the default mode of operation.

**Table 2.6. Divider Selection**

DIVx <sup>1</sup>	Divider Value
Open	÷1 (default)
0	÷2
1	÷4

**Notes:**

1. DIVx are 3-level input pins. Tie low for “0” setting. Tie high for “1” setting. When left open, the pin is internally biased to  $V_{DD}/2$ .

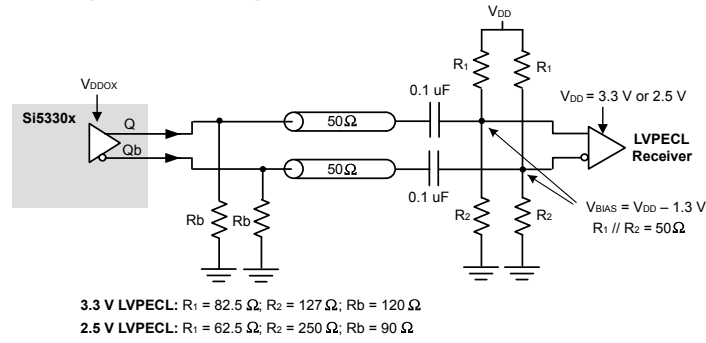
## 2.10 Power Supply ( $V_{DD}$ and $V_{DDOX}$ )

The device includes separate core ( $V_{DD}$ ) and output driver supplies ( $V_{DDOX}$ ). This feature allows the core to operate at a lower voltage than  $V_{DDO}$ , reducing current consumption in mixed supply applications. The core  $V_{DD}$  supports 3.3, 2.5, or 1.8 V. Control signals, such as CLK\_SEL, DIV, and OE, are in the VDD domain. Each output bank has its own  $V_{DDOX}$  supply, supporting 3.3, 2.5, or 1.8 V.

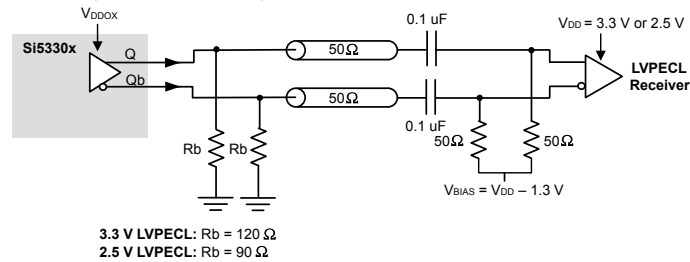
## 2.11 Output Clock Termination Options

The recommended output clock termination options for ac and dc are shown below. Unused outputs should be left unconnected.

### AC-Coupled LVPECL Output Termination Scheme 1

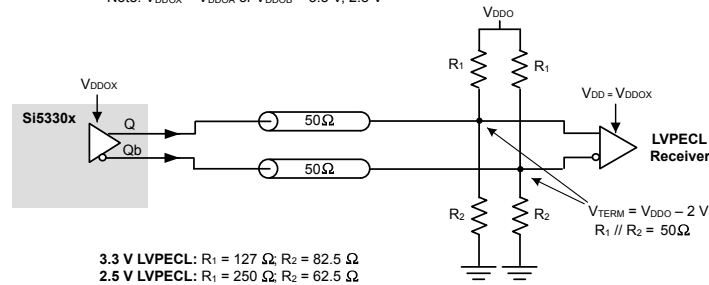


### AC-Coupled LVPECL Output Termination Scheme 2



### DC-Coupled LVPECL Output Termination Scheme 1

Note: V<sub>DD0x</sub> = V<sub>DD0A</sub> or V<sub>DD0B</sub> = 3.3 V, 2.5 V



### DC-Coupled LVPECL Output Termination Scheme 2

Note: V<sub>DD0x</sub> = V<sub>DD0A</sub> or V<sub>DD0B</sub> = 3.3 V, 2.5 V

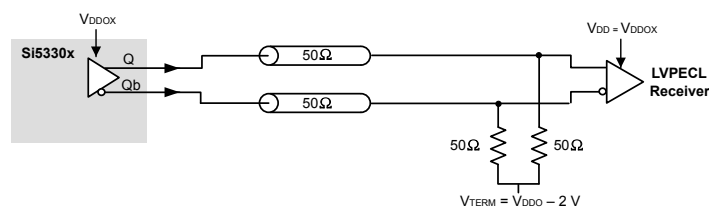


Figure 2.8. LVPECL AC and DC Output Terminations

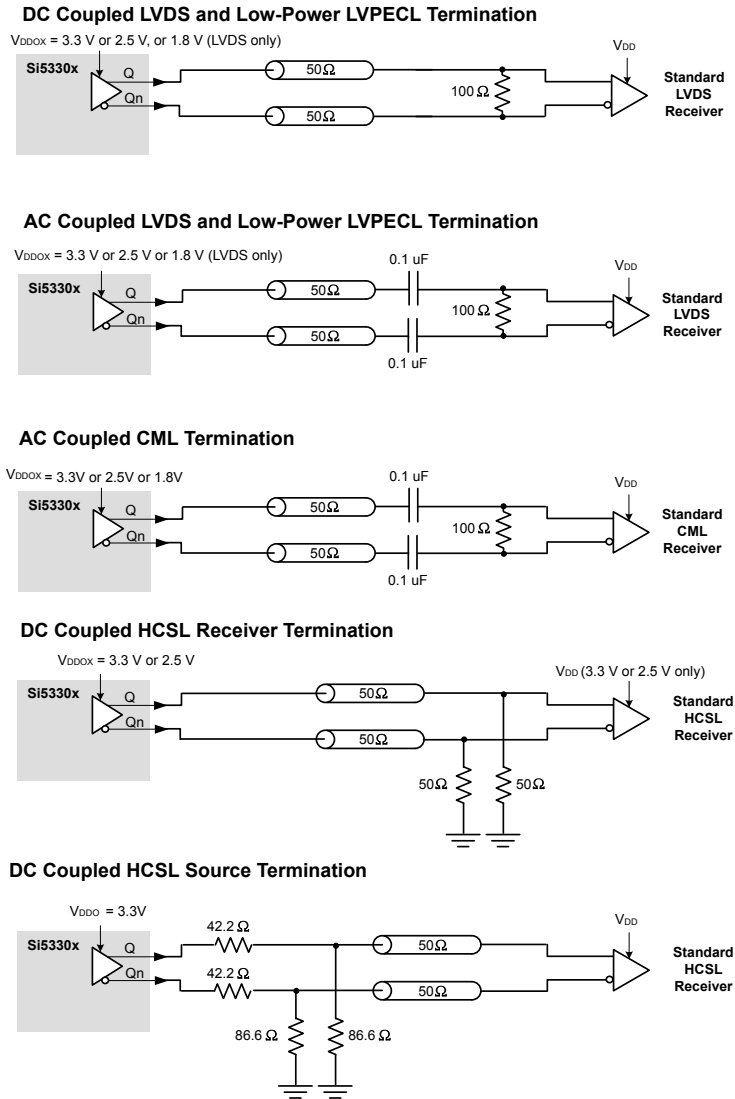


Figure 2.9. LVDS, CML, HCSSL, and Low-Power LVPECL Output Terminations

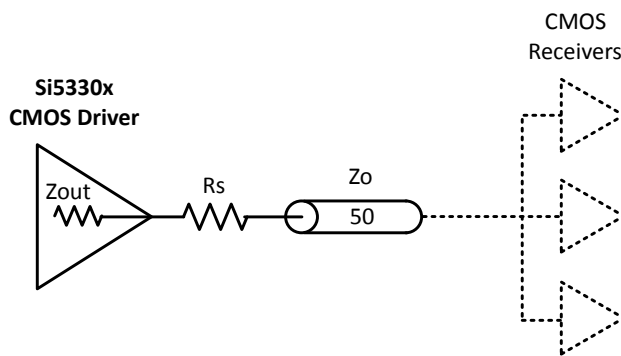


Figure 2.10. LVCMOS Output Termination

Table 2.7. Recommended LVCMOS  $R_S$  Series Termination

SFOUTX[1]	SFOUTX[0]	$R_S$ ( $\Omega$ )		
		3.3 V	2.5 V	1.8 V
0	1	33	33	33

SFOUTX[1]	SFOUTX[0]	$R_S (\Omega)$		
1	0	33	33	33
1	1	33	33	0
Open	0	0	0	0

### 2.12 LVCMOS Output Termination to Support 1.5 V and 1.2 V

LVCMOS clock outputs are natively supported at 1.8, 2.5, and 3.3 V. However, 1.2 V and 1.5 V LVCMOS clock outputs can be supported via a simple resistor divider network that will translate the buffer's 1.8 V output to a lower voltage as shown in the following figure.

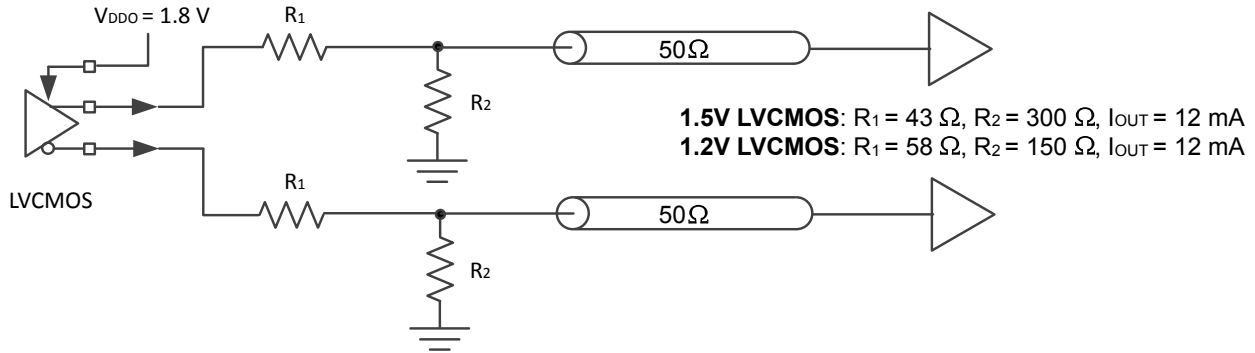


Figure 2.11. 1.5 V and 1.2 V LVCMOS Low-Voltage Output Termination

### 2.13 AC Timing Waveforms

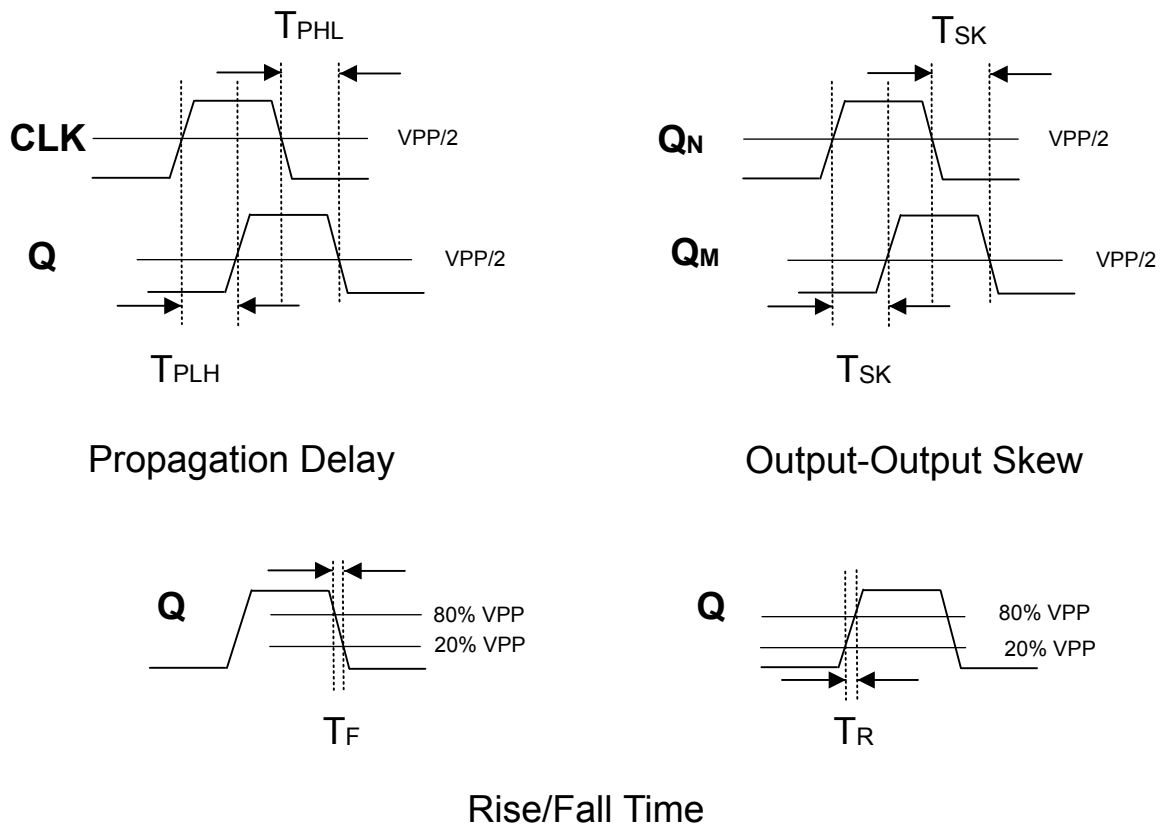


Figure 2.12. AC-Coupled Timing Waveforms

## 2.14 Typical Phase Noise Performance (Differential Input Clock)

Each of the phase noise plots superimposes Source Jitter, Total SE Jitter, and Total Diff Jitter on the same diagram.

- **Source Jitter**—Reference clock phase noise (measured Single-ended to PNA).
- **Total Jitter (SE)**—Combined source and clock buffer phase noise measured as a single-ended output to the phase noise analyzer and integrated from 12 kHz to 20 MHz.
- **Total Jitter (Diff)**—Combined source and clock buffer phase noise measured as a differential output to the phase noise analyzer and integrated from 12 kHz to 20 MHz. The differential measurement as shown in each figure is made using a balun. For more information, see 3. Electrical Specifications.

**Note:** To calculate the total RMS phase jitter when adding a buffer to your clock tree, use the root-sum-square (RSS).

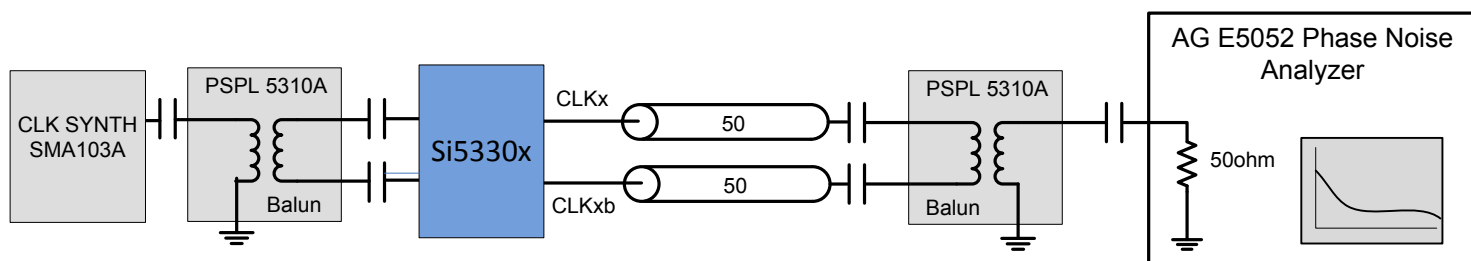
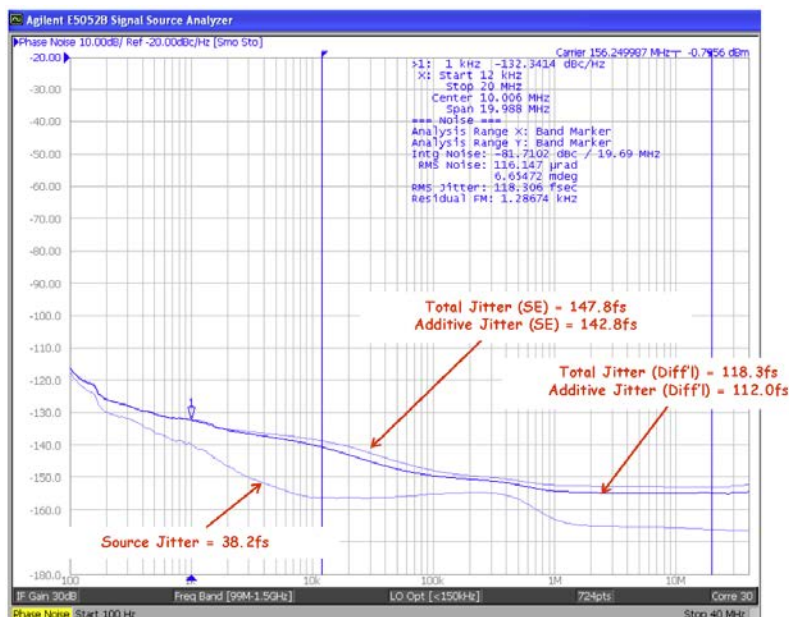
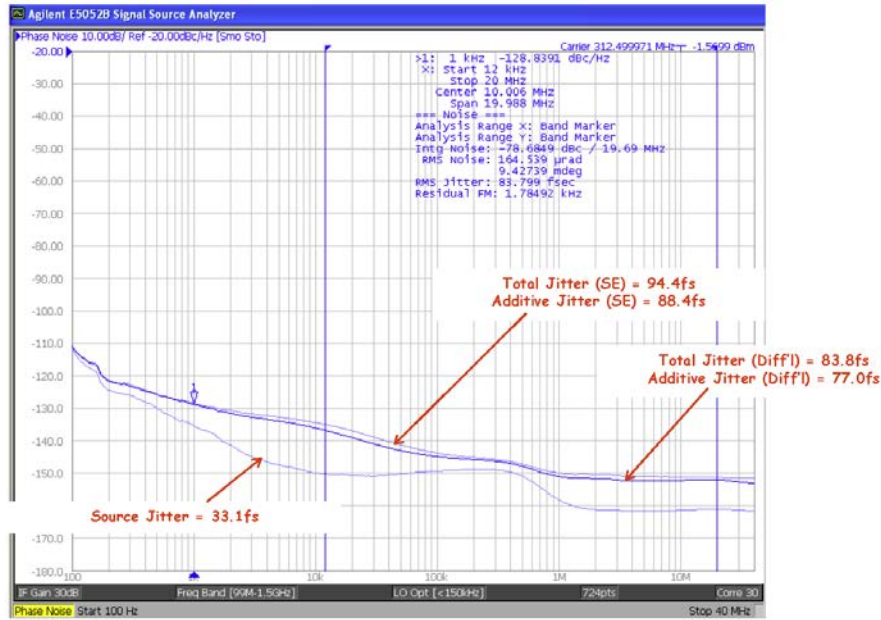


Figure 2.13. Differential Measurement Method Using a Balun



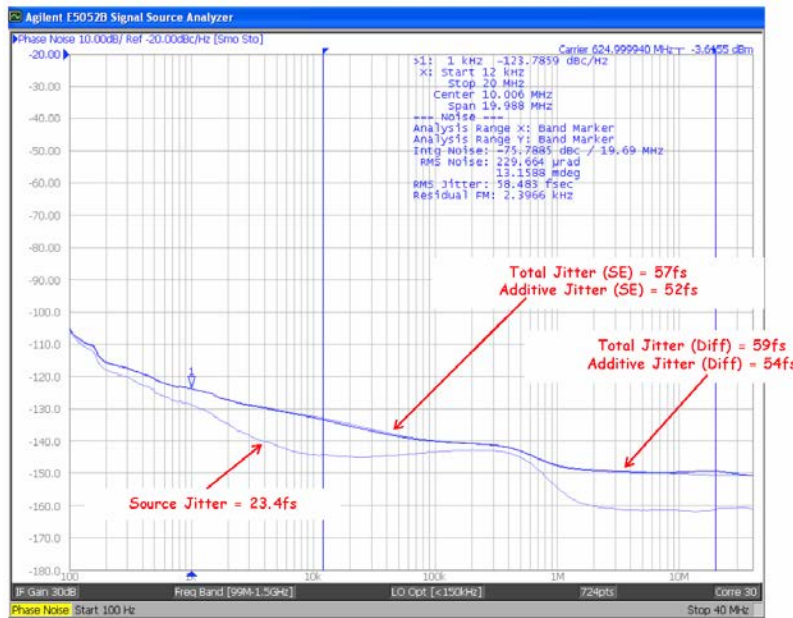
Frequency (MHz)	Differential Input Slew Rate (V/ns)	Source Jitter (fs)	Total Jitter (SE) (fs)	Additive Jitter (SE) (fs)	Total Jitter (Differential) (fs)	Additive Jitter (Differential) (fs)
156.25	1.0	38.2	147.8	142.8	118.3	112.0

Figure 2.14. Total Jitter Differential Input (156.25 MHz)



Frequency (MHz)	Differential Input Slew Rate (V/ns)	Source Jitter (fs)	Total Jitter (SE) (fs)	Additive Jitter (SE) (fs)	Total Jitter (Differential) (fs)	Additive Jitter (Differential) (fs)
312.5	1.0	33.10	94.39	88.39	83.80	76.99

Figure 2.15. Total Jitter Differential Input (312.5 MHz)



Frequency (MHz)	Differential Input Slew Rate (V/ns)	Source Jitter (fs)	Total Jitter (SE) (fs)	Additive Jitter (SE) (fs)	Total Jitter (Differential) (fs)	Additive Jitter (Differential) (fs)
625	1.0	23	57	52	59	54

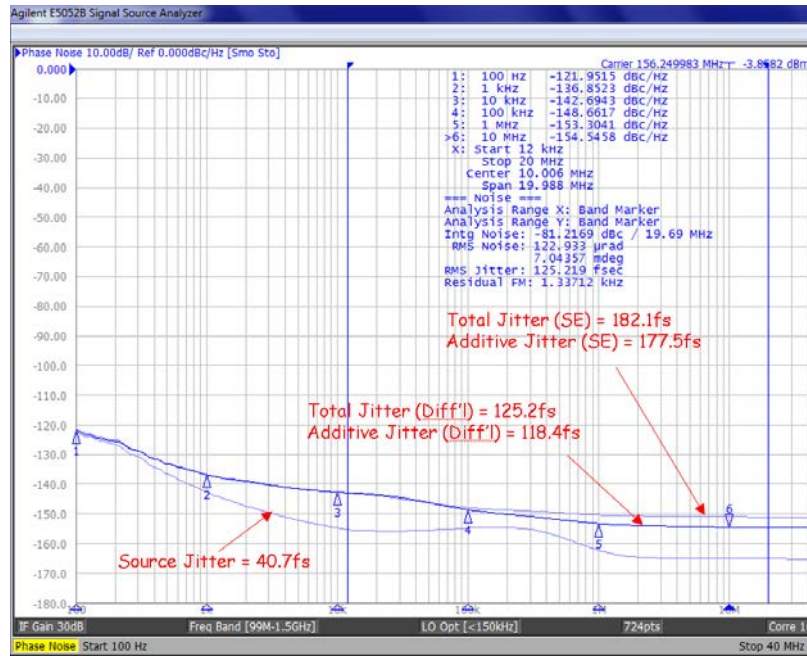
Figure 2.16. Total Jitter Differential Input (625 MHz)



### 2.15 Typical Phase Noise Performance (Single-Ended Input Clock)

For single-ended phase noise measurements, the phase noise analyzer was connected directly without the use of a balun.

The following figure shows three phase noise plots superimposed on the same diagram.



Frequency (MHz)	Single-Ended Input Slew Rate (V/ns)	Source Jitter (fs)	Total Jitter (SE) (fs)	Additive Jitter (SE) (fs)	Total Jitter (Differential) (fs)	Additive Jitter (Differential) (fs)
156.25	1.0	40.74	182.12	177.51	125.22	118.41

Figure 2.17. Total Jitter Single-Ended Input (156.25 MHz)

## 2.16 Input Mux Noise Isolation

The input clock mux is designed to minimize crosstalk between CLK0 and CLK1. This improves phase jitter performance when clocks are present at both the CLK0 and CLK1 inputs. The following figure shows a measurement of the input mux's noise isolation.

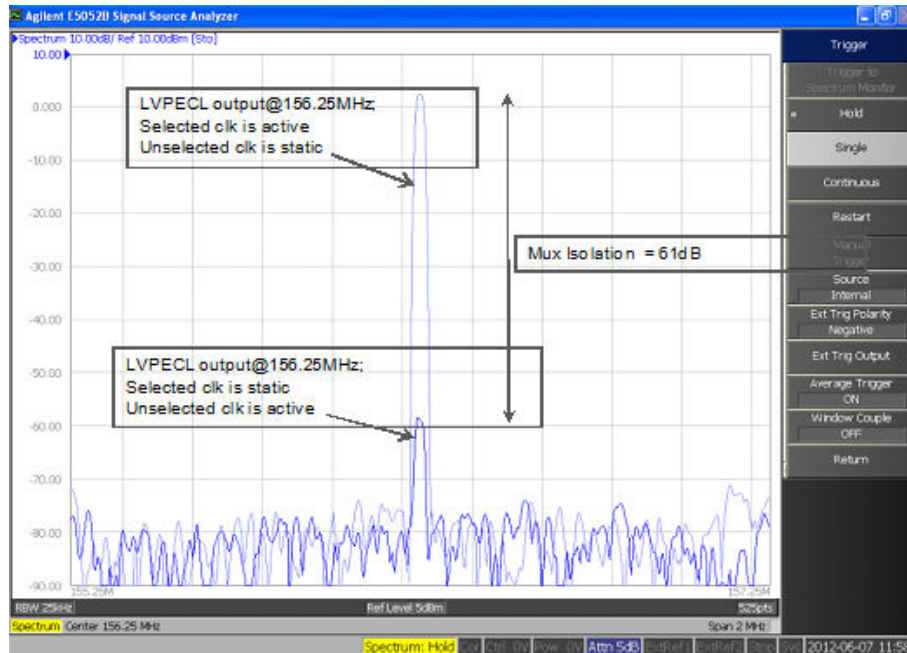


Figure 2.18. Input Mux Noise Isolation (Differential Input Clock, 44-QFN Package)

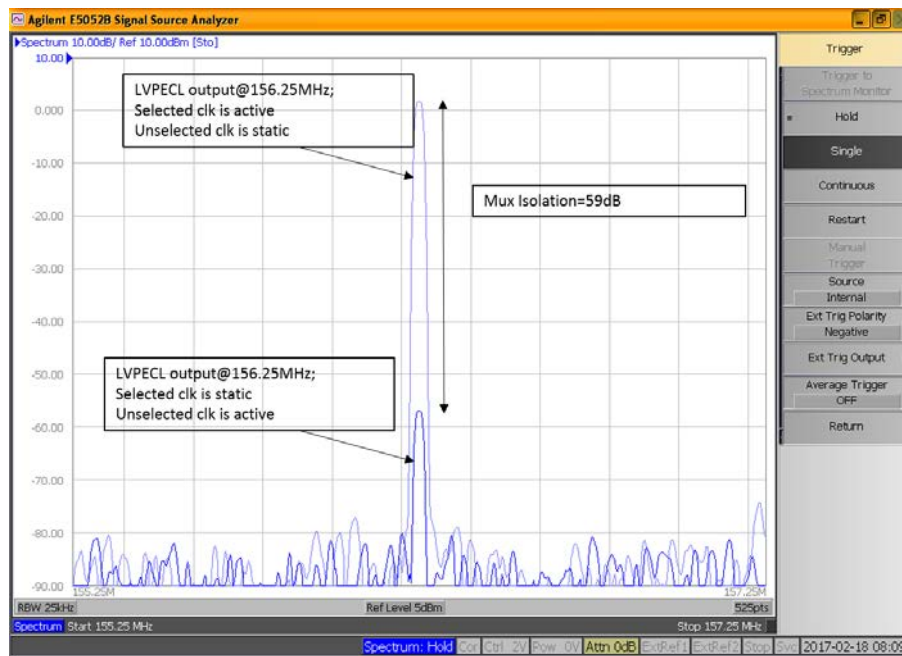


Figure 2.19. Input Mux Noise Isolation (Single-Ended Input Clock, 44-QFN Package)

## 2.17 Power Supply Noise Rejection

The device supports on-chip supply voltage regulation to reject power supply noise and simplify low-jitter operation in real-world environments. This feature enables robust operation alongside FPGAs, ASICs and SoCs and may reduce board-level filtering requirements. See [AN491: Power Supply Rejection for Low-Jitter Clocks](#) for more information.

### 3. Electrical Specifications

**Table 3.1. Recommended Operating Conditions**

Parameter	Symbol	Test Condition	Min	Typ	Max	Unit
Ambient Operating Temperature	$T_A$		-40	—	85	°C
Supply Voltage Range <sup>1</sup>	$V_{DD}$	LVDS, CML	1.71	1.8	1.89	V
			2.38	2.5	2.63	V
			2.97	3.3	3.63	V
		LVPECL, low power LVPECL, LVC MOS	2.38	2.5	2.63	V
			2.97	3.3	3.63	V
		HCSL	2.97	3.3	3.63	V
Output Buffer Supply Voltage <sup>1</sup>	$V_{DDOX}$	LVDS, CML, LVC MOS	1.71	1.8	1.89	V
			2.38	2.5	2.63	V
			2.97	3.3	3.63	V
		LVPECL, low power LVPECL, LVC MOS	2.38	2.5	2.63	V
			2.97	3.3	3.63	V
		HCSL	2.97	3.3	3.63	V

**Note:**

- Core supply  $V_{DD}$  and output buffer supplies  $V_{DDOX}$  are independent. LVC MOS clock input is not supported for  $V_{DD} = 1.8$  V but is supported for LVC MOS clock output for  $V_{DDOX} = 1.8$  V. LVC MOS outputs at 1.5 V and 1.2 V can be supported via a simple resistor divider network.
- See [2.12 LVC MOS Output Termination to Support 1.5 V and 1.2 V](#).

**Table 3.2. Input Clock Specifications**
 $(V_{DD}=1.8\text{ V} \pm 5\%, 2.5\text{ V} \pm 5\%, \text{ or } 3.3\text{ V} \pm 10\%, T_A = -40\text{ to }85\text{ }^\circ\text{C})$ 

Parameter	Symbol	Test Condition	Min	Typ	Max	Unit
Differential Input Common Mode Voltage	$V_{CM}$	$V_{DD} = 2.5\text{ V} \pm 5\%, 3.3\text{ V} \pm 10\%$	0.05	—	—	V
Differential Input Swing (peak-to-peak)	$V_{IN}$		0.2	—	2.2	V
LVC MOS Input High Voltage	$V_{IH}$	$V_{DD} = 2.5\text{ V} \pm 5\%, 3.3\text{ V} \pm 10\%$	$V_{DD} \times 0.7$	—	—	V
LVC MOS Input Low Voltage	$V_{IL}$	$V_{DD} = 2.5\text{ V} \pm 5\%, 3.3\text{ V} \pm 10\%$	—	—	$V_{DD} \times 0.3$	V
Input Capacitance	$C_{IN}$	CLK0 and CLK1 pins with respect to GND	—	5	—	pF

Table 3.3. DC Common Characteristics

 $(V_{DD} = 1.8\text{ V} \pm 5\%, 2.5\text{ V} \pm 5\%, \text{ or } 3.3\text{ V} \pm 10\%, T_A = -40 \text{ to } 85\text{ }^\circ\text{C})$ 

Parameter	Symbol	Test Condition	Min	Typ	Max	Unit
Supply Current	$I_{DD}$		—	65	100	mA
Output Buffer Supply Current (Per Clock Output) @ 100 MHz (differential) @ 200MHz (CMOS)	$I_{DDOX}$	LVPECL (3.3 V) Si53301/2/3/4/5/6/8	—	35	—	mA
		LVPECL (3.3 V) Si53307	—	40	—	mA
		Low Power LVPECL (3.3 V) Si53301/2/4/5/6/7/8	—	35	—	mA
		Low Power LVPECL (3.3 V) Si53303	—	30	—	mA
		LVDS (3.3 V)	—	20	—	mA
		CML (3.3V), Si53301/4/8	—	35	—	mA
		CML (3.3V), Si53302/3/5	—	30	—	mA
		CML (3.3V), Si53306	—	40	—	mA
		CML (3.3V), Si53307	—	60	—	mA
		HCSL, 100 MHz, 2 pF load (3.3 V)	—	35	—	mA
		CMOS (1.8 V, SFOUT = Open/0), per output, $C_L = 5\text{ pF}$ , 200 MHz	—	5	—	mA
		CMOS (2.5 V, SFOUT = Open/0), per output, $C_L = 5\text{ pF}$ , 200 MHz	—	8	—	mA
		CMOS (3.3 V, SFOUT = 0/1), per output, $C_L = 5\text{ pF}$ , 200 MHz Si53306/7	—	20	—	mA
		CMOS (3.3 V, SFOUT = 0/1), per output, $C_L = 5\text{ pF}$ , 200 MHz Si53301/2/3/4/5/8	—	15	—	mA
Voltage Reference	$V_{REF}$	$V_{REF}$ pin, $I_{REF} = \pm 500\text{ }\mu\text{A}$	—	$V_{DD}/2$	—	V
Input High Voltage	$V_{IH}$	SFOUTx, DIVx, CLK_SEL, OEx Si53303	$0.85 \times V_{DD}$	—	—	V
		SFOUTx, DIVx, CLK_SEL, OEx Si53301/2/4/5/6/7/8	$0.8 \times V_{DD}$	—	—	V
Input Mid Voltage	$V_{IM}$	SFOUTx, DIVx 3-level input pins	$0.45 \times V_{DD}$	$0.5 \times V_{DD}$	$0.55 \times V_{DD}$	V
Input Low Voltage	$V_{IL}$	SFOUTx, DIVx, CLK_SEL, OEx Si53301/2/4/5/6/7/8	—	—	$0.2 \times V_{DD}$	V
		SFOUTx, DIVx, CLK_SEL, OEx Si53303	—	—	$0.15 \times V_{DD}$	V
Output Voltage High (LOSx)	$V_{OH}$	$I_{DD} = -1\text{ mA}$	$0.8 \times V_{DD}$	—	—	V
Output Voltage Low (LOSx)	$V_{OL}$	$I_{DD} = 1\text{ mA}$	—	—	$0.2 \times V_{DD}$	V
Internal Pull-down Resistor	$R_{DOWN}$	CLK_SEL, DIVx, SFOUTx,	—	25	—	k $\Omega$

Parameter	Symbol	Test Condition	Min	Typ	Max	Unit
Internal Pull-up Resistor	$R_{UP}$	OEx, DIVx, SFOUTx	—	25	—	k $\Omega$

**Table 3.4. Output Characteristics (LVPECL)** $(V_{DDOX} = 2.5\text{ V} \pm 5\%$ , or  $3.3\text{ V} \pm 10\%$ ,  $T_A = -40$  to  $85\text{ }^\circ\text{C}$ )

Parameter	Symbol	Test Condition	Min	Typ	Max	Unit
Output DC Common Mode Voltage	$V_{COM}$		$V_{DDOX} - 1.595$	—	$V_{DDOX} - 1.245$	V
Single-Ended Output Swing	$V_{SE}$		0.55	0.80	1.050	V

**Note:**

1. Unused outputs can be left floating. Do not short unused outputs to ground.

**Table 3.5. Output Characteristics (Low Power LVPECL)** $(V_{DDOX} = 2.5\text{ V} \pm 5\%$ , or  $3.3\text{ V} \pm 10\%$ ,  $T_A = -40$  to  $85\text{ }^\circ\text{C}$ )

Parameter	Symbol	Test Condition	Min	Typ	Max	Unit
Output DC Common Mode Voltage	$V_{COM}$	$R_L = 100\ \Omega$ across Qn and Qn	$V_{DDOX} - 1.895$		$V_{DDOX} - 1.275$	V
Single-Ended Output Swing	$V_{SE}$	$R_L = 100\ \Omega$ across Qn and Qn	0.25	0.60	0.85	V

**Table 3.6. Output Characteristics (CML)** $(V_{DDOX} = 1.8\text{ V} \pm 5\%$ ,  $2.5\text{ V} \pm 5\%$ , or  $3.3\text{ V} \pm 10\%$ ,  $T_A = -40$  to  $85\text{ }^\circ\text{C}$ )

Parameter	Symbol	Test Condition	Min	Typ	Max	Unit
Single-Ended Output Swing	$V_{SE}$	Terminated as shown in <a href="#">Figure 2.9 LVDS, CML, HCSL, and Low-Power LVPECL Output Terminations</a> on page 13 (CML termination).	300	400	550	mV

**Table 3.7. Output Characteristics (LVDS)** $(V_{DDOX} = 1.8\text{ V} \pm 5\%, 2.5\text{ V} \pm 5\%, \text{ or } 3.3\text{ V} \pm 10\%, T_A = -40 \text{ to } 85\text{ }^\circ\text{C})$ 

Parameter	Symbol	Test Condition	Min	Typ	Max	Unit
Single-Ended Output Swing	$V_{SE}$	$R_L = 100\ \Omega$ across $Q_N$ and $Q_N$ Si53301/2/4/5/6/7/8	247	—	490	mV
		$R_L = 100\ \Omega$ across $Q_N$ and $Q_N$ Si53303	247	—	454	mV
Output Common Mode Voltage ( $V_{DDO} = 2.5\text{ V}$ or $3.3\text{ V}$ )	$V_{COM1}$	$V_{DDOX} = 2.38$ to $2.63\text{ V}$ , $2.97$ to $3.63\text{ V}$ , $R_L = 100\ \Omega$ across $Q_N$ and $Q_N$	1.10	1.25	1.35	V
Output Common Mode Voltage ( $V_{DDO} = 1.8\text{ V}$ )	$V_{COM2}$	$V_{DDOX} = 1.71$ to $1.89\text{ V}$ , $R_L = 100\ \Omega$ across $Q_N$ and $Q_N$ Si53301/2/4/5/6/7/8	0.85	0.97	1.25	V
		$V_{DDOX} = 1.71$ to $1.89\text{ V}$ , $R_L = 100\ \Omega$ across $Q_N$ and $Q_N$ Si53303	0.85	0.97	1.1	V

**Table 3.8. Output Characteristics (LVCMOS)** $(V_{DDOX} = 1.8\text{ V} \pm 5\%, 2.5\text{ V} \pm 5\%, \text{ or } 3.3\text{ V} \pm 10\%, T_A = -40 \text{ to } 85\text{ }^\circ\text{C})$ 

Parameter	Symbol	Test Condition	Min	Typ	Max	Unit
Output Voltage High	$V_{OH}$	Si53301/2/4/5/6/7/8	$0.75 \times V_{DDOX}$	—	—	V
		Si53303	$0.8 \times V_{DDOX}$	—	—	V
Output Voltage Low	$V_{OL}$	Si53301/2/4/5/6/7/8	—	—	$0.25 \times V_{DDOX}$	V
		Si53303	—	—	$0.2 \times V_{DDOX}$	V

**Note:**

- $I_{OH}$  and  $I_{OL}$  per the Output Signal Format Table for specific  $V_{DDOX}$  and SFOUTx settings.

**Table 3.9. Output Characteristics (HCSL)** $(V_{DDOX} = 2.5\text{ V} \pm 5\% \text{ or } 3.3\text{ V} \pm 10\%, T_A = -40 \text{ to } 85\text{ }^\circ\text{C})$ 

Parameter	Symbol	Test Condition	Min	Typ	Max	Unit
Output Voltage High	$V_{OH}$	$R_L = 50\ \Omega$ to GND Si53301/2/3/4/5/6/8	550	700	900	mV
		$R_L = 50\ \Omega$ to GND Si53307	550	700	850	mV
Output Voltage Low	$V_{OL}$	$R_L = 50\ \Omega$ to GND	-150	0	150	mV
Single-Ended Output Swing	$V_{SE}$	$R_L = 50\ \Omega$ to GND	550	700	850	mV
Crossing Voltage	$V_C$	$R_L = 50\ \Omega$ to GND	250	350	550	mV

Table 3.10. AC Characteristics

 $(V_{DD} = V_{DDOX} = 1.8\text{ V} \pm 5\%, 2.5\text{ V} \pm 5\%, \text{ or } 3.3\text{ V} \pm 10\%, T_A = -40\text{ to } 85\text{ }^\circ\text{C})$ 

Parameter	Symbol	Test Condition	Min	Typ	Max	Unit
LOSx Clear Time	$T_{LOSCLR}$	F < 100 MHz	—	$T_{PER} + 15$	—	ns
		F > 100 MHz	—	25	—	ns
LOSx Activation Time	$T_{LOSACT}$		—	15	—	$\mu\text{s}$
Frequency	F	LVPECL, low power LVPECL, LVDS, CML, HCSL <sup>1</sup>	1	—	725	MHz
		LVC MOS	1	—	200	MHz
Duty Cycle <sup>6</sup>	$D_C$	200 MHz, 20/80% $T_R/T_F < 10\%$ of period (LVC MOS) (12 mA drive)	40	50	60	%
		80% $T_R/T_F < 10\%$ of period (Differential)	48	50	52	%
Minimum Input Clock Slew Rate <sup>5</sup>	SR	Required to meet prop delay and additive jitter specifications (20–80%)	0.75	—	—	V/ns
Output Rise/Fall Time	$T_R/T_F$	LVDS, 20/80%	—	—	325	ps
		LVPECL, 20/80%	—	—	350	ps
		HCSL <sup>1</sup> , 20/80%	—	—	280	ps
		CML, 20/80%	—	—	350	ps
		Low-Power LVPECL, 20/80%	—	—	350	ps
		LVC MOS 200 MHz, 20/80%, 2 pF load	—	—	750	ps
Minimum Input Pulse Width	$T_W$		500	—	—	ps
Propagation Delay	$T_{PLH}, T_{PHL}$	LVC MOS (12 mA drive with no load)	1250	2000	2750	ps
		LVPECL Si53301/2/3/4/5/8	600	800	1000	ps
		LVPECL Si53306/7	675	875	1075	ps
		LVDS Si53301/2/3/4/5/8	600	800	1000	ps
		LVDS Si53306/7	675	875	1075	ps
Output Enable Time Si53301/2/4/5/8	$T_{EN}$	F = 1 MHz	—	2500	—	ns
		F = 100 MHz	—	30	—	ns
		F = 725 MHz	—	5	—	ns
Output Enable Time Si53303	$T_{EN}$	F = 1 MHz	—	2000	—	ns
		F = 100 MHz	—	60	—	ns
		F = 725 MHz	—	50	—	ns

Parameter	Symbol	Test Condition	Min	Typ	Max	Unit
Output Enable Time Si53306/7	$T_{EN}$	F = 1 MHz	—	1570	—	ns
		F = 100 MHz	—	20	—	ns
		F = 725 MHz	—	5	—	ns
Output Disable Time Si53301/2/4/5/8	$T_{DIS}$	F = 1 MHz	—	2000	—	ns
		F = 100 MHz	—	30	—	ns
		F = 725 MHz	—	5	—	ns
Output Disable Time Si53303	$T_{DIS}$	F = 1 MHz	—	2000	—	ns
		F = 100 MHz	—	25	—	ns
		F = 725 MHz	—	15	—	ns
Output Disable Time Si53306/7	$T_{DIS}$	F = 1 MHz	—	2000	—	ns
		F = 100 MHz	—	35	—	ns
		F = 725 MHz	—	5	—	ns
Output to Output Skew <sup>2</sup>	$T_{SK}$	LVC MOS (12 mA drive to no load) <sup>7</sup>	—	50	120	ps
		LVPECL	—	35	75	ps
		LVDS	—	35	85	ps
Part to Part Skew <sup>3</sup>	$T_{PS}$	Differential	—	—	150	ps
Power Supply Noise Rejection <sup>4</sup> (Si53305/2)	PSNR	10 kHz sinusoidal noise	—	-63	—	dBc
		100 kHz sinusoidal noise	—	-62	—	dBc
		500 kHz sinusoidal noise	—	-58	—	dBc
		10 MHz sinusoidal noise	—	-55	—	dBc
Power Supply Noise Rejection <sup>4</sup> (Si53308/4/1)	PSNR	10 kHz sinusoidal noise	—	-65	—	dBc
		100 kHz sinusoidal noise	—	-63	—	dBc
		500 kHz sinusoidal noise	—	-60	—	dBc
		10 MHz sinusoidal noise	—	-55	—	dBc
Power Supply Noise Rejection <sup>4</sup> (Si53307/6)	PSNR	10 kHz sinusoidal noise	—	-72	—	dBc
		100 kHz sinusoidal noise	—	-70	—	dBc
		500 kHz sinusoidal noise	—	-67	—	dBc
		10 MHz sinusoidal noise	—	-62	—	dBc
Power Supply Noise Rejection <sup>4</sup> (Si53303)	PSNR	10 kHz sinusoidal noise	—	-90	—	dBc
		100 kHz sinusoidal noise	—	-90	—	dBc
		500 kHz sinusoidal noise	—	-80	—	dBc
		10 MHz sinusoidal noise	—	-70	—	dBc



Parameter	Symbol	Test Condition	Min	Typ	Max	Unit
<b>Notes:</b>						
1. HCSL measurements were made with receiver termination and applies for 2.5 V and 3.3 V only. See <a href="#">Figure 2.9 LVDS, CML, HCSL, and Low-Power LVPECL Output Terminations on page 13</a> .						
2. Output to Output skew specified for outputs with an identical configuration.						
3. Defined as skew between any output on different devices operating at the same supply voltage, temperature, and equal load condition. Using the same type of inputs on each device, the outputs are measured at the differential cross points.						
4. Measured for 156.25 MHz carrier frequency. Sine-wave noise added to $V_{DDOX}$ (3.3 V = 100 mV <sub>PP</sub> ) and noise spur amplitude measured. See "AN491: Power Supply Rejection for Low-Jitter Clocks" for further details.						
5. TBD						
6. 50% input duty cycle.						
7. LVCMOS outputs are in phase.						

**Table 3.11. Additive Jitter, Differential Clock Input**

$V_{DD}$	Input <sup>1,2</sup>	Output	Additive Jitter (fs rms, 12 kHz to 20 MHz) <sup>3</sup>				
	Freq (MHz)	Clock Format	Amplitude $V_{IN}$ (Single-Ended, Peak-to-Peak)	Differential 20%-80% Slew Rate (V/ns)	Clock Format	Typ	Max
3.3	725	Differential	0.15	0.637	LVPECL	45	65
3.3	725	Differential	0.15	0.637	LVDS	50	65
3.3	156.25	Differential	0.5	0.458	LVPECL	160	185
3.3	156.25	Differential	0.5	0.458	LVDS	150	200
2.5	725	Differential	0.15	0.637	LVPECL	45	65
2.5	725	Differential	0.15	0.637	LVDS	50	65
2.5	156.25	Differential	0.5	0.458	LVPECL	145	185
2.5	156.25	Differential	0.5	0.458	LVDS	145	195

**Notes:**

- For best additive jitter results, use the fastest slew rate possible. See "AN766: Understanding and Optimizing Clock Buffer's Additive Jitter Performance" for more information.
- AC-coupled differential inputs.
- Measured differentially using a balun at the phase noise analyzer input. See [Figure 2.13 Differential Measurement Method Using a Balun on page 15](#).

Table 3.12. Additive Jitter, Single-Ended Clock Input

V <sub>DD</sub>	Input <sup>1,2</sup>	Output	Additive Jitter (fs rms, 12 kHz to 20 MHz) <sup>3</sup>				
	Freq (MHz)	Clock Format	Amplitude V <sub>IN</sub> (single-ended, peak to peak)	SE 20%-80% Slew Rate (V/ns)	Clock Format	Typ	Max
3.3	200	Single-ended	1.70	1	LVC MOS <sup>4</sup>	120	160
3.3	156.25	Single-ended	2.18	1	LVPECL	160	185
3.3	156.25	Single-ended	2.18	1	LVDS	150	200
3.3	156.25	Single-ended	2.18	1	LVC MOS <sup>4</sup>	130	180
2.5	200	Single-ended	1.70	1	LVC MOS <sup>5</sup>	120	160
2.5	156.25	Single-ended	2.18	1	LVPECL	145	185
2.5	156.25	Single-ended	2.18	1	LVDS	145	195
2.5	156.25	Single-ended	2.18	1	LVC MOS <sup>5</sup>	140	180

**Notes:**

1. For best additive jitter results, use the fastest slew rate possible. See "AN766: Understanding and Optimizing Clock Buffer's Additive Jitter Performance" for more information.
2. DC-coupled single-ended inputs.
3. Measured single-ended at the phase noise analyzer input. See [Figure 2.17 Total Jitter Single-Ended Input \(156.25 MHz\) on page 17](#).
4. Drive Strength: 12 mA, 3.3 V (SFOUT = 11). LVC MOS jitter is measured single-ended.
5. Drive Strength: 9 mA, 2.5 V (SFOUT = 11). LVC MOS jitter is measured single-ended.

Table 3.13. Thermal Conditions

Package	Parameter	Symbol	Test Condition	Value	Unit
3 x 3 mm QFN <sup>1</sup>	Thermal Resistance, Junction to Ambient	$\theta_{JA}$	Still air	60	°C/W
	Thermal Resistance, Junction to Case	$\theta_{JC}$	Still air	10.8	°C/W
	Thermal Resistance, Junction to Board	$\theta_{JB}$	Still air	34.1	°C/W
5 x 5 mm QFN <sup>2</sup>	Thermal Resistance, Junction to Ambient	$\theta_{JA}$	Still air	50.3	°C/W
	Thermal Resistance, Junction to Case	$\theta_{JC}$	Still air	10.3	°C/W
	Thermal Resistance, Junction to Board	$\theta_{JB}$	Still air	30.9	°C/W
7 x 7 mm QFN <sup>3</sup>	Thermal Resistance, Junction to Ambient	$\theta_{JA}$	Still air	46.2	°C/W
	Thermal Resistance, Junction to Case	$\theta_{JC}$	Still air	27.1	°C/W
	Thermal Resistance, Junction to Board	$\theta_{JB}$	Still air	28	°C/W

**Note:**

1. Based on a 2-layer, PCB with Dimension 3"x4.5". PCB Thickness of 1.6mm. PCB Center Land with 4 Via to backside, 75% Cu coverage.
2. Based on PCB with dimension 3" x 4.5", PCB Thickness of 1.6 mm. PCB Center Land with 4 Via to top plane.
3. Based on 2-layer PCB with dimension 3" x 4.5", PCB Thickness of 1.6 mm. PCB Center Land with 16 Via to back side with 75% Cu coverage.

Table 3.14. Absolute Maximum Ratings

Parameter	Symbol	Test Condition	Min	Typ	Max	Unit
Storage Temperature	$T_S$		-55	—	150	°C
Supply Voltage	$V_{DD}$		-0.5	—	3.8	V
Input Voltage	$V_{IN}$		-0.5	—	$V_{DD} + 0.3$	V
Output Voltage	$V_{OUT}$		—	—	$V_{DD} + 0.3$	V
ESD Sensitivity	HBM	HBM, 100 pF, 1.5 k $\Omega$	—	—	2000	V
ESD Sensitivity	CDM		—	—	500	V
Peak Soldering Reflow Temperature	$T_{PEAK}$	Pb-Free; Solder reflow profile per JEDEC J-STD-020	—	—	260	°C
Maximum Junction Temperature	$T_J$		—	—	125	°C

**Note:**

1. Stresses beyond those listed in this table may cause permanent damage to the device. Functional operation specification compliance is not implied at these conditions. Exposure to maximum rating conditions for extended periods may affect device reliability.

#### 4. Detailed Block Diagrams

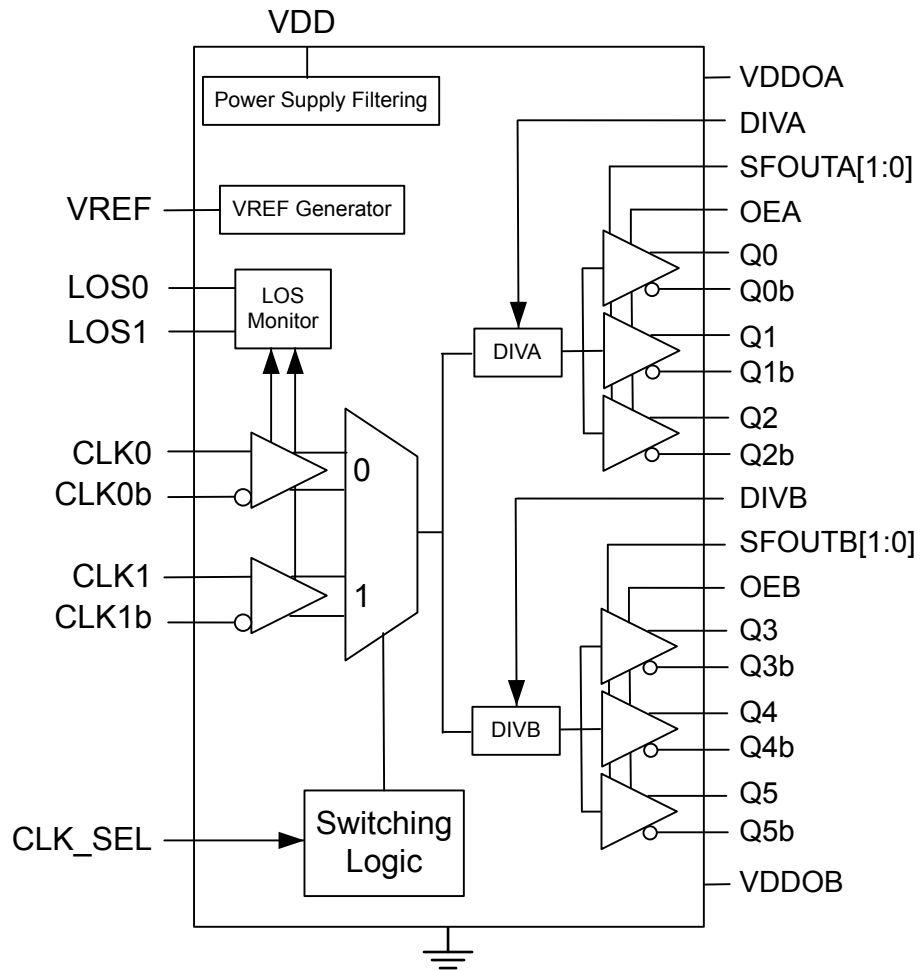


Figure 4.1. Si53301 Block Diagram

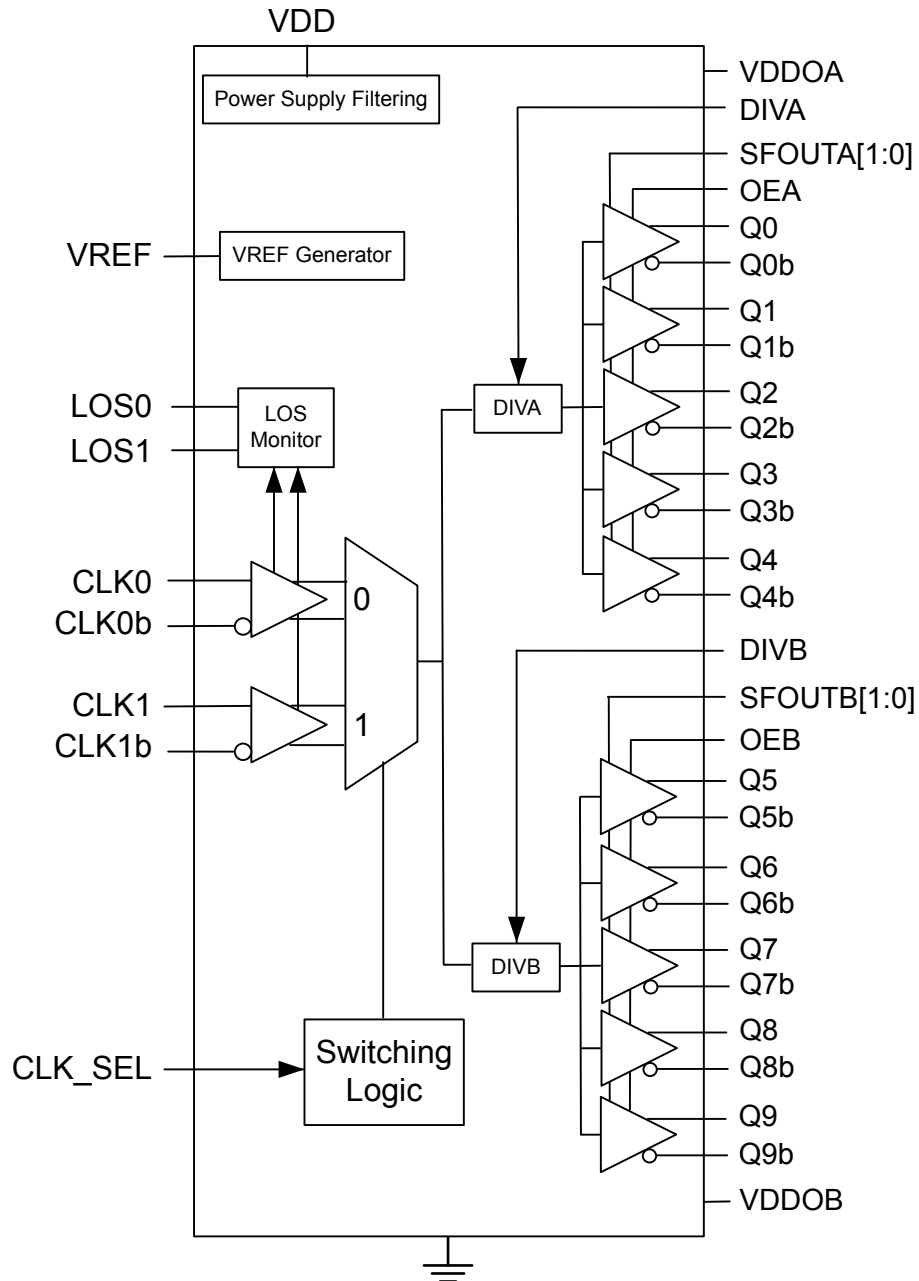


Figure 4.2. Si53302 Block Diagram

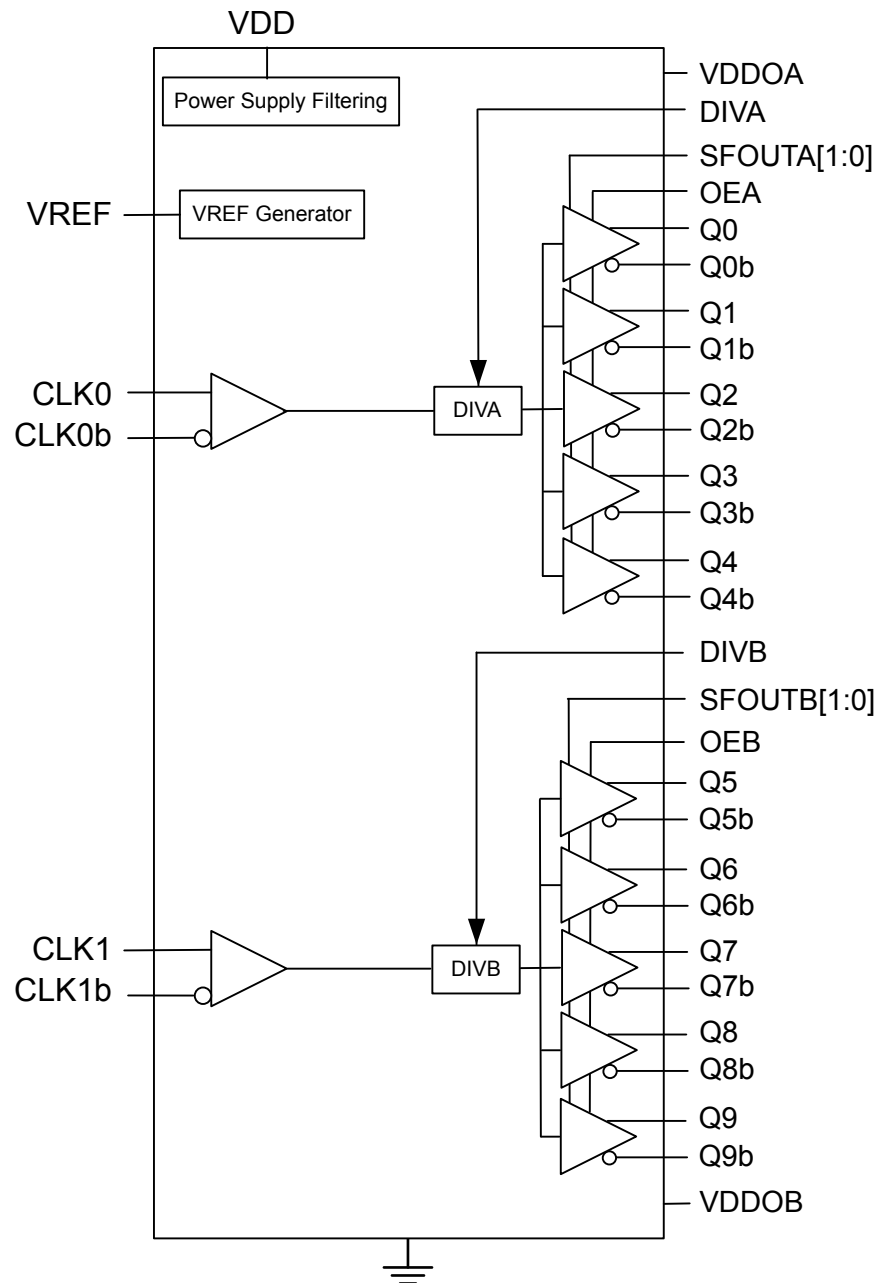


Figure 4.3. Si53303 Block Diagram

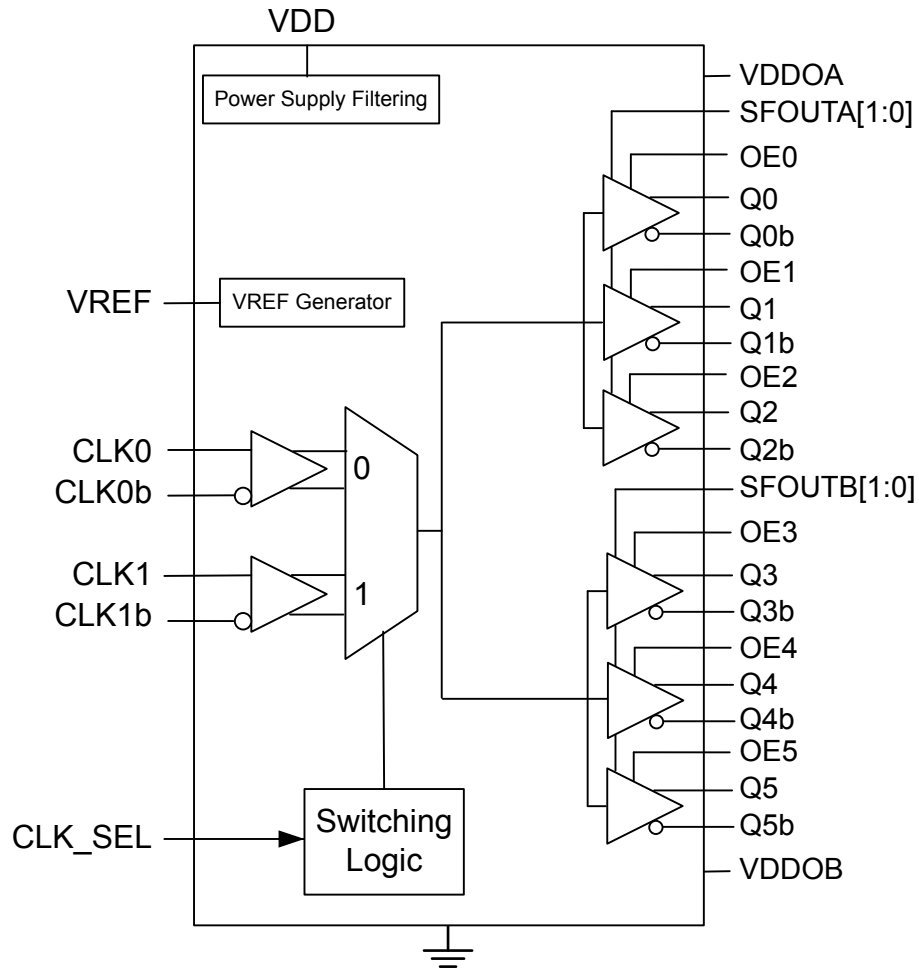


Figure 4.4. Si53304 Block Diagram

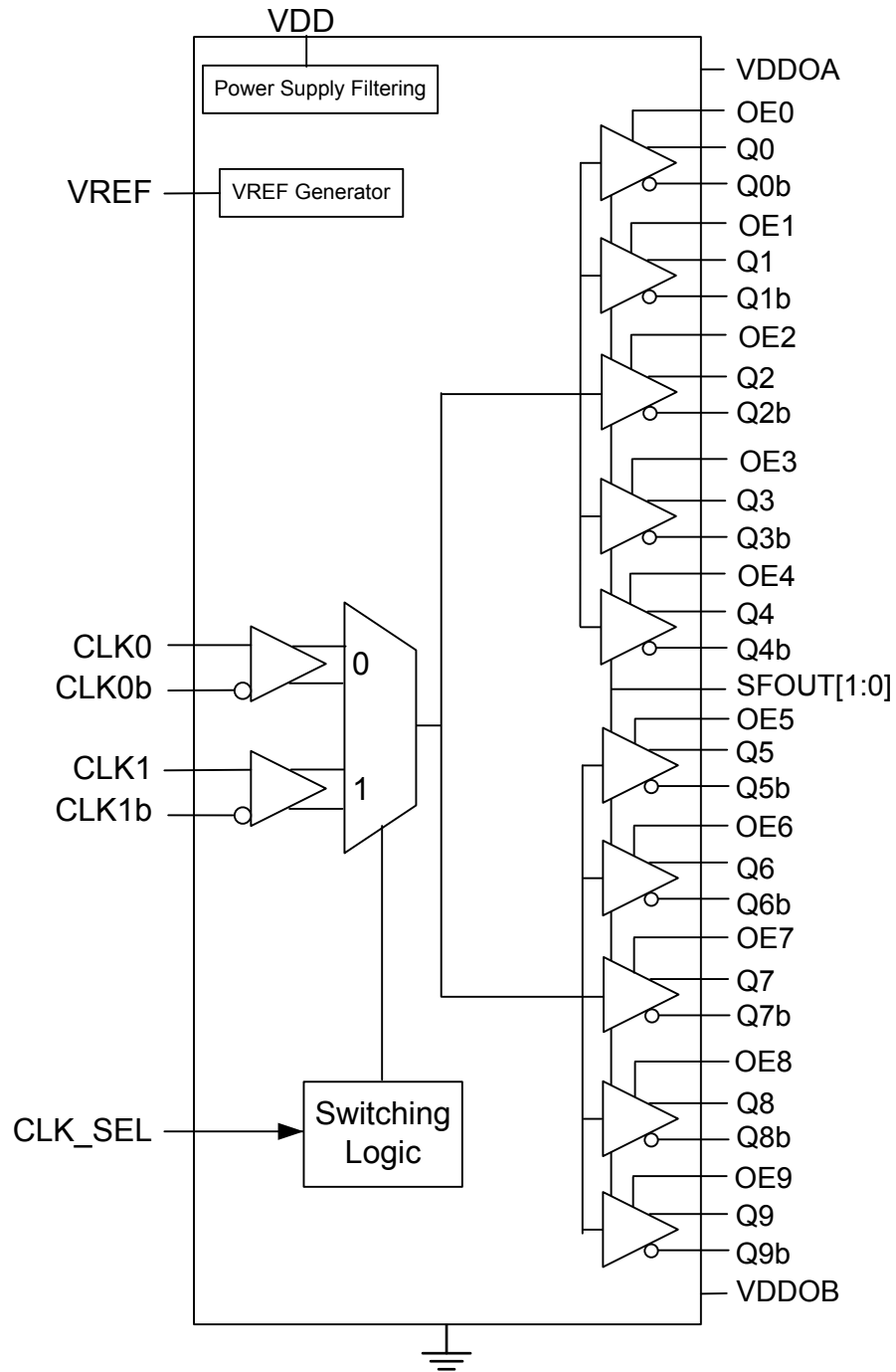


Figure 4.5. Si53305 Block Diagram



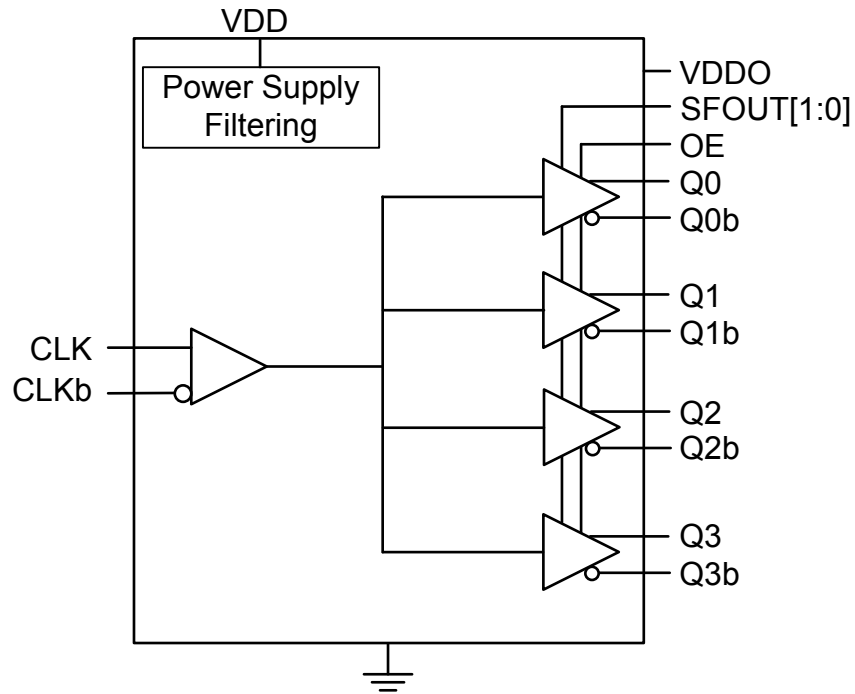


Figure 4.6. Si53306 Block Diagram

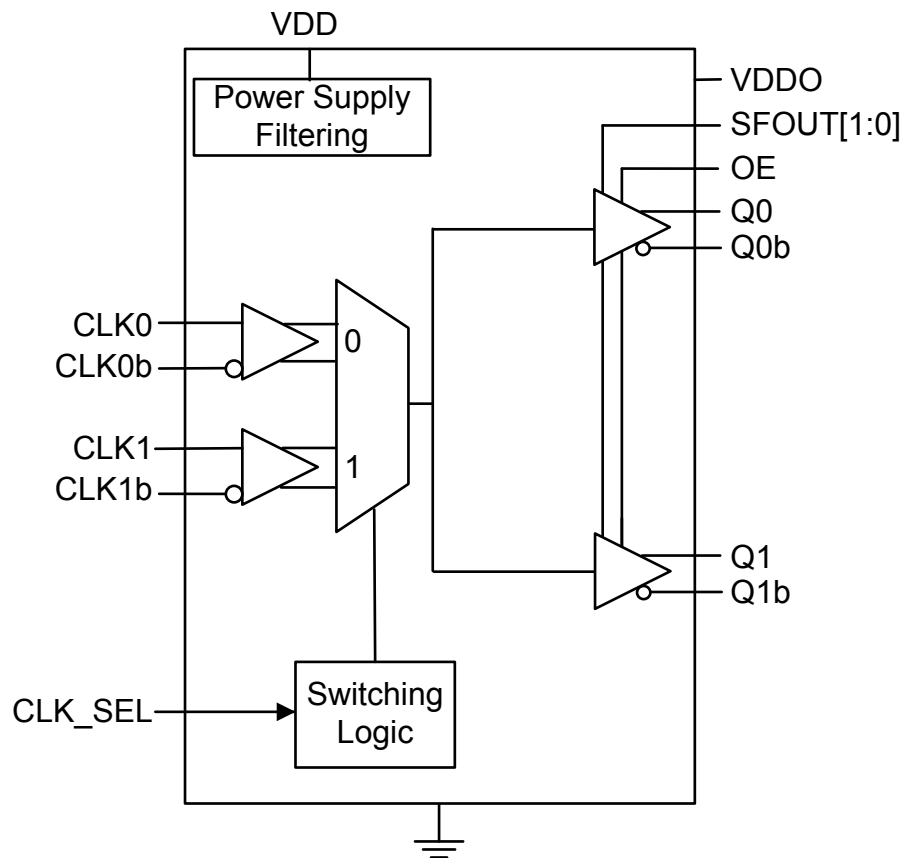


Figure 4.7. Si53307 Block Diagram

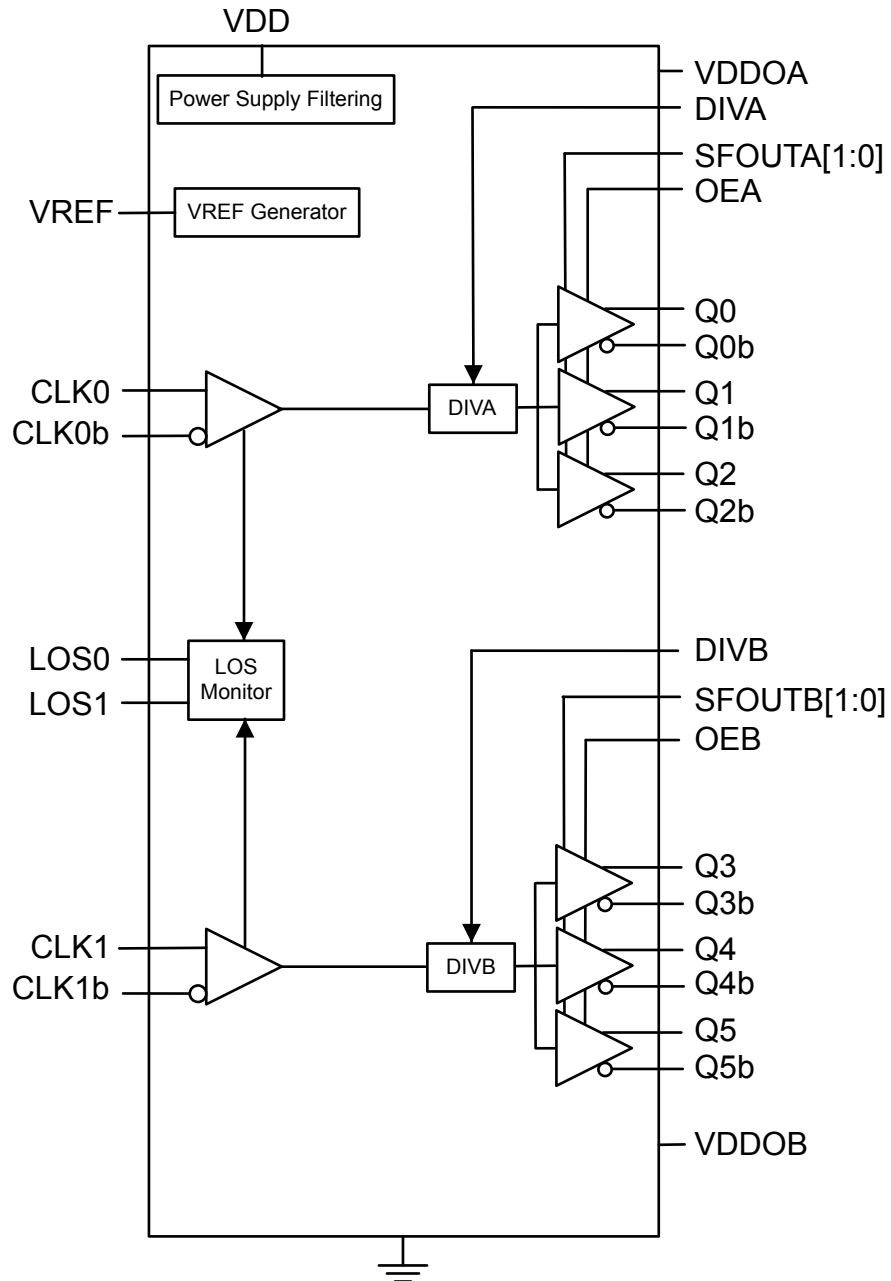
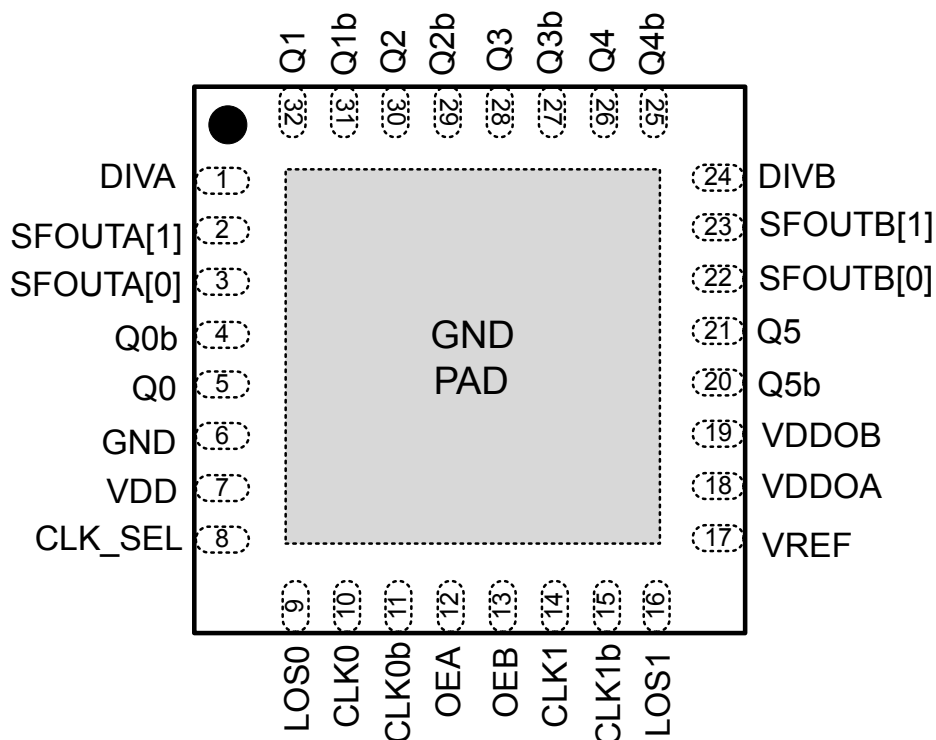


Figure 4.8. Si53308 Block Diagram

## 5. Pin Descriptions

### 5.1 Si53301 Pin Descriptions



**Table 5.1. Si53301 -QFN Pin Descriptions**

Pin	Name	Type <sup>1</sup>	Description
1	DIVA	I	Output divider control pin for Bank A Three-level input control. Internally biased at $V_{DD}/2$ . Can be left floating or tied to ground or $V_{DD}$ .
2	SFOUTA[1]	I	Output signal format control pin for Bank A Three-level input control. Internally biased at $V_{DD}/2$ . Can be left floating or tied to ground or $V_{DD}$ .
3	SFOUTA[0]	I	Output signal format control pin for Bank A Three-level input control. Internally biased at $V_{DD}/2$ . Can be left floating or tied to ground or $V_{DD}$ .
4	Q0b	O	Output clock 0 (complement)
5	Q0	O	Output clock 0
6	GND	GND	Ground
7	VDD	P	Core voltage supply. Bypass with 1.0 $\mu\text{F}$ capacitor placed as close to the VDD pin as possible.

Pin	Name	Type <sup>1</sup>	Description
8	CLK_SEL	I	Mux input select pin Clock inputs are switched without the introduction of glitches. When CLK_SEL is high, CLK1 is selected. When CLK_SEL is low, CLK0 is selected. CLK_SEL contains an internal pull-down resistor.
9	LOS0	O	The LOS0 status pin indicates whether a clock is present at the CLK0 input. CLK0 input clock present LOS0 = 0 CLK0 input clock not present LOS0 = 1
10	CLK0	I	Input clock 0
11	CLK0b	I	Input clock 0 (complement) When the CLK0 is driven by a single-end input, connect CLK0b to $V_{DD}/2$ .
12	OEA	I	Output enable—Bank A (Outputs Q0 to Q2). When OE = high, the Bank A outputs are enabled. When OE = low, Q is held low, and Qb is held high for differential formats. For LVCMOS, both Q and Qb are held low when OE is set low. OEA contains an internal pull-up resistor.
13	OEB	I	Output enable—Bank B (Outputs Q3 to Q5) When OE = high, the Bank B outputs are enabled. When OE = low, Q is held low, and Qb is held high for differential formats. For LVCMOS, both Q and Qb are held low when OE is set low. OEB contains an internal pull-up resistor.
14	CLK1	I	Input clock 1
15	CLK1b	I	Input clock 1 (complement) When the CLK1 is driven by a single-end input, connect CLK1b to $V_{DD}/2$ .
16	LOS1	O	The LOS1 status pin indicates whether a clock is present at the CLK1 input: CLK1 input clock present LOS1 = 0 CLK1 input clock not present LOS1 = 1
17	VREF	O	Reference voltage output.
18	VDDOA	P	Output voltage supply—Bank A (Outputs: Q0 to Q2) Bypass with 1.0 $\mu$ F capacitor and place as close to the VDDOA pin as possible.
19	VDDOB	P	Output voltage supply—Bank B (Outputs: Q3 to Q5) Bypass with 1.0 $\mu$ F capacitor and place as close to the VDDOB pin as possible.
20	Q5b	O	Output clock 5 (complement)
21	Q5	O	Output clock 5
22	SFOUTB[0]	I	Output signal format control pin for Bank B. Three-level input control. Internally biased at $V_{DD}/2$ . Can be left floating or tied to ground or $V_{DD}$ .

Pin	Name	Type <sup>1</sup>	Description
23	SFOUTB[1]	I	Output signal format control pin for Bank B. Three-level input control. Internally biased at $V_{DD}/2$ . Can be left floating or tied to ground or $V_{DD}$ .
24	DIVB	I	Output divider configuration bit for Bank B. Three-level input control. Internally biased at $V_{DD}/2$ . Can be left floating or tied to ground or $V_{DD}$ .
25	Q4b	O	Output clock 4 (complement)
26	Q4	O	Output clock 4
27	Q3b	O	Output clock 3 (complement)
28	Q3	O	Output clock 3
29	Q2b	O	Output clock 2 (complement)
30	Q2	O	Output clock 2
31	Q1b	O	Output clock 1 (complement)
32	Q1	O	Output clock 1
GND Pad	GND	GND	Power supply ground and thermal relief.

**Note:**

1. Pin types are: I = input, O = output, P = power, GND = ground.

## 5.2 Si53302 Pin Descriptions

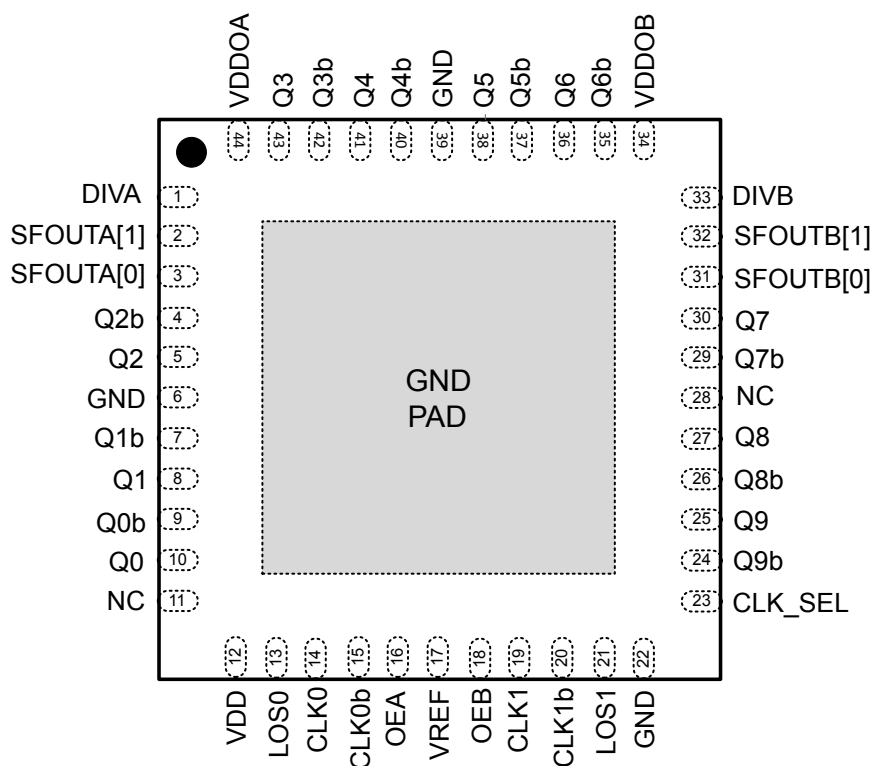


Table 5.2. Si53302 44-QFN Pin Descriptions

Pin #	Name	Type <sup>1</sup>	Description
1	DIVA	I	Output divider control pin for Bank A. Three-level input control. Internally biased at $V_{DD}/2$ . Can be left floating or tied to ground or $V_{DD}$ .
2	SFOUTA[1]	I	Output signal format control pin for Bank A. Three-level input control. Internally biased at $V_{DD}/2$ . Can be left floating or tied to ground or $V_{DD}$ .
3	SFOUTA[0]	I	Output signal format control pin for Bank A. Three-level input control. Internally biased at $V_{DD}/2$ . Can be left floating or tied to ground or $V_{DD}$ .
4	Q2b	O	Output clock 2 (complement).
5	Q2	O	Output clock 2.
6	GND	GND	Ground.
7	Q1b	O	Output clock 1 (complement).
8	Q1	O	Output clock 1.
9	Q0b	O	Output clock 0 (complement).
10	Q0	O	Output clock 0.
11	NC		No connect. Do not connect this pin to anything.

Pin #	Name	Type <sup>1</sup>	Description
12	VDD	P	Core voltage supply. Bypass with a 1.0 $\mu$ F capacitor placed as close to the pin as possible.
13	LOS0	O	The LOS0 status pin indicates whether a clock is present at the CLK0 input: CLK0 input clock present LOS0 = 0 CLK0 input clock not present LOS0 = 1
14	CLK0	I	Input clock 0.
15	CLK0b	I	Input clock 0 (complement). When the CLK0 is driven by a single-end LVCMOS input, connect CLK0b to $V_{DD}/2$ .
16	OEA	I	Output enable—Bank A. When OEA = high, the Bank A outputs are enabled. When OEA = low, Q is held low and Qb is held high for differential formats. For LVCMOS, both Q and Qb are held low when OEA is set low. OEA contains an internal pull-up resistor.
17	VREF	O	Reference voltage output. See section 2.3 Voltage Reference ( $V_{REF}$ ) for details.
18	OEB	I	Output enable—Bank B. When OEB = high, the Bank B outputs are enabled. When OEB = low, Q is held low and Qb is held high for differential formats. For LVCMOS, both Q and Qb are held low when OEB is set low. OEB contains an internal pull-up resistor.
19	CLK1	I	Input clock 1.
20	CLK1b	I	Input clock 1 (complement). When the CLK1 is driven by a single-end LVCMOS input, connect CLK1b to $V_{DD}/2$ .
21	LOS1	O	The LOS1 status pin indicates whether a clock is present at the CLK1 input: CLK1 input clock present LOS1 = 0 CLK1 input clock not present LOS1 = 1
22	GND	GND	Ground.
23	CLK_SEL	I	MUX input select pin (LVCMOS). When CLK_SEL is high, CLK1 is selected. When CLK_SEL is low, CLK0 is selected. CLK_SEL contains an internal pull-down resistor.
24	Q9b	O	Output clock 9 (complement).
25	Q9	O	Output clock 9.
26	Q8b	O	Output clock 8 (complement).
27	Q8	O	Output clock 8.
28	NC		No connect.

Pin #	Name	Type <sup>1</sup>	Description
29	Q7b	O	Output clock 7 (complement).
30	Q7	O	Output clock 7.
31	SFOUTB[0]	I	Output signal format control pin for Bank B. Three-level input control. Internally biased at $V_{DD}/2$ . Can be left floating or tied to ground or $V_{DD}$ .
32	SFOUTB[1]	I	Output signal format control pin for Bank B. Three-level input control. Internally biased at $V_{DD}/2$ . Can be left floating or tied to ground or $V_{DD}$ .
33	DIVB	I	Output divider configuration bit for Bank B. Three-level input control. Internally biased at $V_{DD}/2$ . Can be left floating or tied to ground or $V_{DD}$ .
34	VDDOB	P	Output Clock Voltage Supply—Bank B (Outputs: Q5 to Q9). Bypass with a 1.0 $\mu$ F capacitor placed as close to the pin as possible.
35	Q6b	O	Output clock 6 (complement).
36	Q6	O	Output clock 6.
37	Q5b	O	Output clock 5 (complement).
38	Q5	O	Output clock 5.
39	GND	GND	Ground.
40	Q4b	O	Output clock 4 (complement).
41	Q4	O	Output clock 4.
42	Q3b	O	Output clock 3 (complement).
43	Q3	O	Output clock 3.
44	VDDOA	P	Output Voltage Supply—Bank A (Outputs: Q0 to Q4). Bypass with a 1.0 $\mu$ F capacitor placed as close to the pin as possible.
GND Pad	GND	GND	Ground Pad. Power supply ground and thermal relief.

**Note:**

1. Pin types are: I = input, O = output, P = power, GND = ground.



## 5.3 Si53303 Pin Descriptions

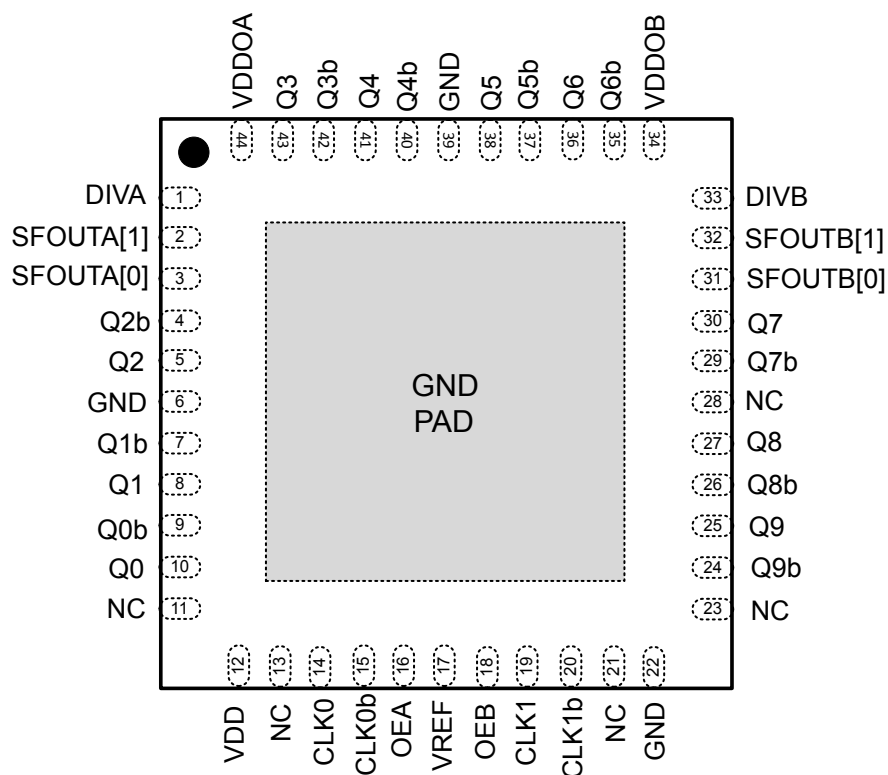


Table 5.3. Si53303 44-QFN Pin Descriptions

Pin #	Name	Type <sup>1</sup>	Description
1	DIVA	I	Output divider control pin for Bank A Three-level input control. Internally biased at VDD/2. Can be left floating or tied to ground or V <sub>DD</sub> .
2	SFOUTA[1]	I	Output signal format control pin for Bank A Three-level input control. Internally biased at VDD/2. Can be left floating or tied to ground or V <sub>DD</sub> .
3	SFOUTA[0]	I	Output signal format control pin for Bank A Three-level input control. Internally biased at VDD/2. Can be left floating or tied to ground or V <sub>DD</sub> .
4	Q2b	O	Output clock 2 (complement)
5	Q2	O	Output clock 2
6	GND	GND	Ground
7	Q1b	O	Output clock 1 (complement)
8	Q1	O	Output clock 1
9	Q0b	O	Output clock 0 (complement)
10	Q0	O	Output clock 0
11	NC		No connect. Do not connect this pin to anything.

Pin #	Name	Type <sup>1</sup>	Description
12	VDD	P	Core voltage supply Bypass with 1.0 $\mu$ F capacitor placed as close to the VDD pin as possible
13	NC		No connect
14	CLK0	I	Input clock 0
15	CLK0b	I	Input clock 0 (complement) When the CLK0 is driven by a single-end LVCMOS input, connect CLK0b to $V_{DD}/2$ .
16	OEA	I	Output enable—Bank A When OE = high, the Bank A outputs are enabled When OE = low, Q is held low and Qb is held high for differential formats For LVCMOS, both Q and Qb are held low when OE is set low OEA contains an internal pull-up resistor
17	VREF	O	Reference voltage output. See section 2.3 Voltage Reference ( $V_{REF}$ ) for details.
18	OEB	I	Output enable—Bank B When OE = high, the Bank B outputs are enabled When OE = low, Q is held low and Qb is held high for differential formats For LVCMOS, both Q and Qb are held low when OE is set low OEB contains an internal pull-up resistor.
19	CLK1	I	Input clock 1
20	CLK1b	I	Input clock 1 (complement) When the CLK1 is driven by a single-end LVCMOS input, connect CLK1b to $V_{DD}/2$ .
21	NC		No connect
22	GND	GND	Ground
23	NC		No connect
24	Q9b	O	Output clock 9 (complement)
25	Q9	O	Output clock 9
26	Q8b	O	Output clock 8 (complement)
27	Q8	O	Output clock 8
28	NC		No connect
29	Q7b	O	Output clock 7 (complement)
30	Q7	O	Output clock 7
31	SFOUTB[0]	I	Output signal format control pin for Bank B Three-level input control. Internally biased at $V_{DD}/2$ . Can be left floating or tied to ground or $V_{DD}$ .
32	SFOUTB[1]	I	Output signal format control pin for Bank B Three-level input control. Internally biased at $V_{DD}/2$ . Can be left floating or tied to ground or $V_{DD}$ .

Pin #	Name	Type <sup>1</sup>	Description
33	DIVB	I	Output divider configuration bit for Bank B Three-level input control. Internally biased at $V_{DD}/2$ . Can be left floating or tied to ground or $V_{DD}$ .
34	VDDOB	P	Output Clock Voltage Supply—Bank B (Outputs: Q5 to Q9) Bypass with 1.0 $\mu$ F capacitor and place close to the VDDOB pin as possible.
35	Q6b	O	Output clock 6 (complement)
36	Q6	O	Output clock 6
37	Q5b	O	Output clock 5 (complement)
38	Q5	O	Output clock 5.
39	GND	GND	Ground.
40	Q4b	O	Output clock 4 (complement)
41	Q4	O	Output clock 4.
42	Q3b	O	Output clock 3 (complement)
43	Q3	O	Output clock 3
44	VDDOA	P	Output Voltage Supply—Bank A (Outputs: Q0 to Q4) Bypass with 1.0 $\mu$ F capacitor and place close to the VDDOA pin as possible.
GND Pad	GND	GND	Ground Pad Power supply ground and thermal relief.

**Note:**

1. Pin types are: I = input, O = output, P = power, GND = ground.

## 5.4 Si53304 Pin Descriptions

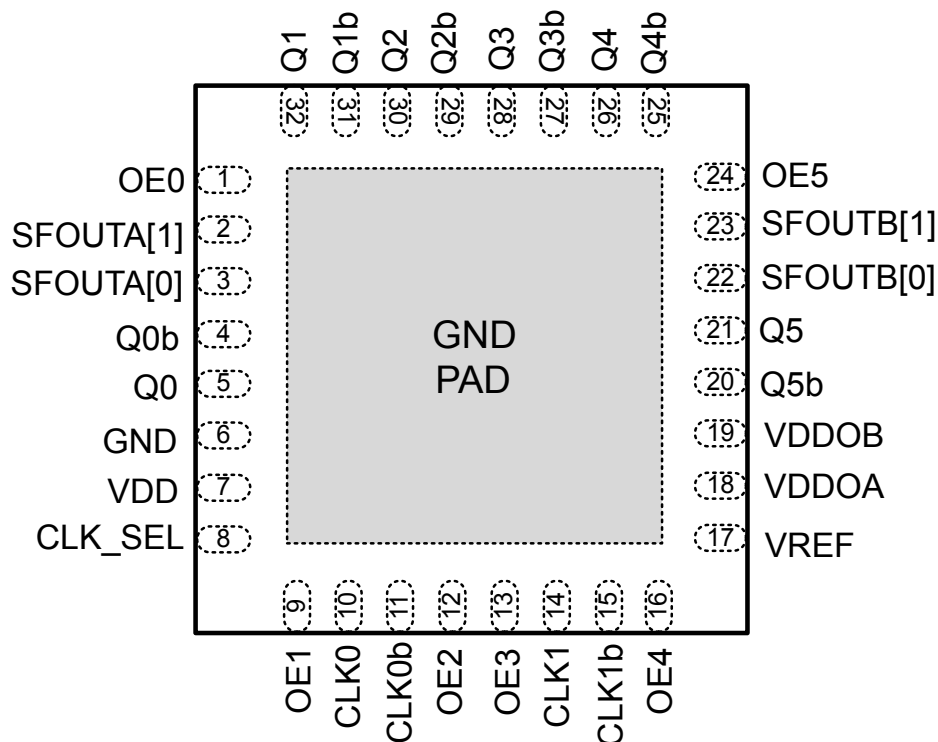


Table 5.4. Si53304 32-QFN Pin Descriptions

Pin	Name	Type <sup>1</sup>	Description
1	OE0	I	Output enable—Output 0 When OE = high, Q0 is enabled. When OE = low, Q is held low and Qb is held high for differential formats. For LVCMOS, both Q and Qb are held low when OE is set low. This pin contains an internal pull-up resistor.
2	SFOUTA[1]	I	Output signal format control pin for Bank A Three level input control. Internally biased at $V_{DD}/2$ . Can be left floating or tied to ground or $V_{DD}$ .
3	SFOUTA[0]	I	Output signal format control pin for Bank A Three level input control. Internally biased at $V_{DD}/2$ . Can be left floating or tied to ground or $V_{DD}$ .
4	Q0b	O	Output clock 0 (complement)
5	Q0	O	Output clock 0
6	GND	GND	Ground
7	VDD	P	Core voltage supply Bypass with 1.0 $\mu$ F capacitor and place as close to the $V_{DD}$ pin as possible.

Pin	Name	Type <sup>1</sup>	Description
8	CLK_SEL	I	Mux input select pin (LVCMOS) When CLK_SEL is high, CLK1 is selected. When CLK_SEL is low, CLK0 is selected. CLK_SEL contains an internal pull-down resistor.
9	OE1	I	Output enable—Output 1 When OE = high, Q1 is enabled. When OE = low, Q is held low and Qb is held high for differential formats. For LVCMOS, both Q and Qb are held low when OE is set low. This pin contains an internal pull-up resistor.
10	CLK0	I	Input clock 0
11	CLK0b	I	Input clock 0 (complement) When the CLK0 is driven by a single-end input, connect CLK0b to $V_{DD}/2$ .
12	OE2	I	Output enable—Output 2 When OE = high, Q2 is enabled. When OE = low, Q is held low and Qb is held high for differential formats. For LVCMOS, both Q and Qb are held low when OE is set low. OE2 contains an internal pull-up resistor.
13	OE3	I	Output enable—Output 3 When OE = high, Q3 is enabled. When OE = low, Q is held low and Qb is held high for differential formats. For LVCMOS, both Q and Qb are held low when OE is set low. OE3 contains an internal pull-up resistor.
14	CLK1	I	Input clock 1
15	CLK1b	I	Input clock 1 (complement) When the CLK1 is driven by a single-end input, connect CLK1b to $V_{DD}/2$ .
16	OE4	I	Output enable—Output 4 When OE = high, Q4 is enabled. When OE = low, Q is held low and Qb is held high for differential formats. For LVCMOS, both Q and Qb are held low when OE is set low. This pin contains an internal pull-up resistor.
17	VREF	O	See <a href="#">2.3 Voltage Reference (<math>V_{REF}</math>)</a> for details.
18	VDDOA	P	Output voltage supply—Bank A (Outputs: Q0 to Q2) Bypass with 1.0 $\mu$ F capacitor and place as close to the VDDOA pin as possible.
19	VDDOB	P	Output voltage supply—Bank B (Outputs: Q3 to Q5) Bypass with 1.0 $\mu$ F capacitor and place as close to the VDDOB pin as possible.
20	Q5b	O	Output clock 5 (complement)

Pin	Name	Type <sup>1</sup>	Description
21	Q5	O	Output clock 5
22	SFOUTB[0]	I	Output signal format control pin for Bank B Three level input control. Internally biased at $V_{DD}/2$ . Can be left floating or tied to ground or $V_{DD}$ .
23	SFOUTB[1]	I	Output signal format control pin for Bank B Three level input control. Internally biased at $V_{DD}/2$ . Can be left floating or tied to ground or $V_{DD}$ .
24	OE5	I	Output enable—Output 5 When OE = high, Q5 is enabled. When OE = low, Q is held low and Qb is held high for differential formats. For LVCMOS, both Q and Qb are held low when OE is set low. This pin contains an internal pull-up resistor.
25	Q4b	O	Output clock 4 (complement)
26	Q4	O	Output clock 4
27	Q3b	O	Output clock 3 (complement)
28	Q3	O	Output clock 3
29	Q2b	O	Output clock 2 (complement)
30	Q2	O	Output clock 2
31	Q1b	O	Output clock 1 (complement)
32	Q1	O	Output clock 1
GND Pad	GND	GND	Ground Pad Power supply ground and thermal relief.

**Note:**

1. Pin types are: I = input, O = output, P = power, GND = ground.

## 5.5 Si53305 Pin Descriptions

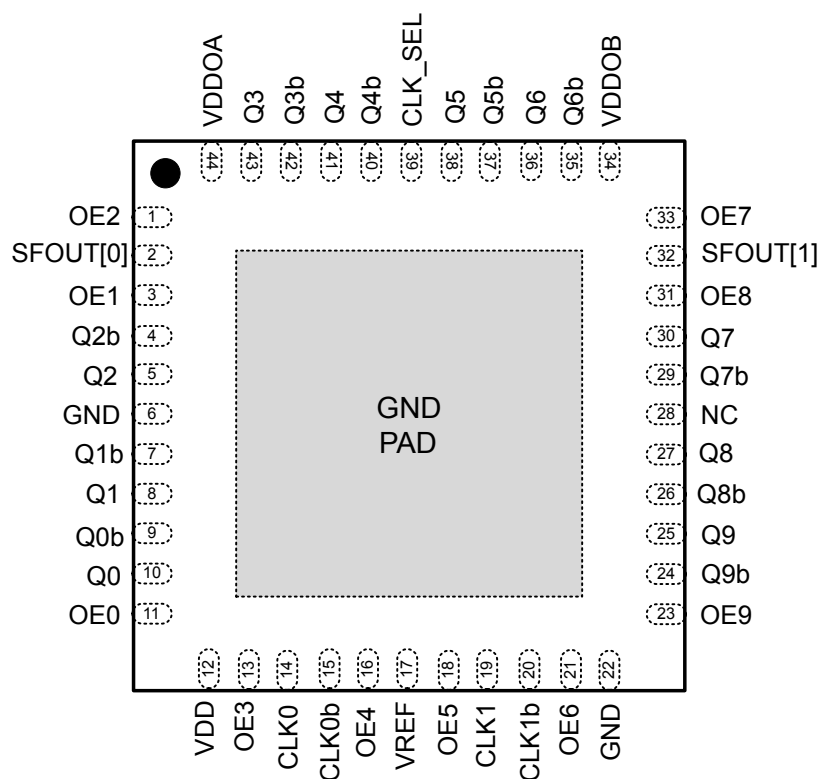


Table 5.5. Si53305 44-QFN Pin Descriptions

Pin #	Name	Type <sup>1</sup>	Description
1	OE2	I	Output enable—Output 2 When OE = high, Q2 is enabled. When OE = low, Q is held low, and Qb is held high for differential formats. For LVCMOS, both Q and Qb are held low when OE is set low. OE2 contains an internal pull-up resistor.
2	SFOUT[0]	I	Output signal format control pin [0] Three-level input control. Internally biased at $V_{DD}/2$ . Can be left floating or tied to ground or $V_{DD}$ .
3	OE1	I	Output enable—Output 1 When OE = high, Q1 is enabled. When OE = low, Q is held low, and Qb is held high for differential formats. For LVCMOS, both Q and Qb are held low when OE is set low. OE1 contains an internal pull-up resistor.
4	Q2b	O	Output clock 2 (complement)
5	Q2	O	Output clock 2
6	GND	GND	Ground
7	Q1b	O	Output clock 1 (complement)

Pin #	Name	Type <sup>1</sup>	Description
8	Q1	O	Output clock 1
9	Q0b	O	Output clock 0 (complement)
10	Q0	O	Output clock 0
11	OE0	I	Output enable—Output 0 When OE = high, Q0 is enabled. When OE = low, Q is held low, and Qb is held high for differential formats. For LVCMOS, both Q and Qb are held low when OE is set low. OE0 contains an internal pull-up resistor.
12	VDD	P	Core voltage supply Bypass with 1.0 $\mu$ F capacitor and place close to the VDD pin as possible
13	OE3	I	Output Enable 3 When OE = high, Q3 is enabled. When OE = low, Q is held low, and Qb is held high for differential formats. For LVCMOS, both Q and Qb are held low when OE is set low. OE3 contains an internal pull-up resistor.
14	CLK0	I	Input clock 0
15	CLK0b	I	Input clock 0 (complement) When CLK0 is driven by a single-ended input, connect CLK0b to $V_{DD}/2$ .
16	OE4	I	Output Enable 4 When OE = high, Q4 is enabled. When OE = low, Q is held low, and Qb is held high for differential formats. For LVCMOS, both Q and Qb are held low when OE is set low. OE4 contains an internal pull-up resistor.
17	VREF	O	Reference voltage output. See <a href="#">2.3 Voltage Reference (<math>V_{REF}</math>)</a> for details.
18	OE5	I	Output Enable 5 When OE = high, Q5 is enabled. When OE = low, Q is held low, and Qb is held high for differential formats. For LVCMOS, both Q and Qb are held low when OE is set low. OE5 contains an internal pull-up resistor.
19	CLK1	I	Input clock 1
20	CLK1b	I	Input clock 1 (complement) When CLK1 is driven by a single-ended input, connect CLK1b to $V_{DD}/2$ .



Pin #	Name	Type <sup>1</sup>	Description
21	OE6	I	Output Enable 6 When OE = high, Q6 is enabled. When OE = low, Q is held low, and Qb is held high for differential formats. For LVCMOS, both Q and Qb are held low when OE is set low. OE6 contains an internal pull-up resistor.
22	GND	GND	Ground
23	OE9	I	Output Enable 9 When OE = high, Q9 is enabled. When OE = low, Q is held low, and Qb is held high for differential formats. For LVCMOS, both Q and Qb are held low when OE is set low. OE9 contains an internal pull-up resistor.
24	Q9b	O	Output clock 9 (complement)
25	Q9	O	Output clock 9
26	Q8b	O	Output clock 8 (complement)
27	Q8	O	Output clock 8
28	NC		No Connect
29	Q7b	O	Output clock 7 (complement)
30	Q7	O	Output clock 7
31	OE8	I	Output Enable 8 When OE = high, Q8 is enabled. When OE = low, Q is held low, and Qb is held high for differential formats. For LVCMOS, both Q and Qb are held low when OE is set low. OE8 contains an internal pull-up resistor.
32	SFOUT[1]	I	Output signal format control pin [1] Three-level input control. Internally biased at $V_{DD}/2$ . Can be left floating or tied to ground or $V_{DD}$ .
33	OE7	I	Output Enable 7 When OE = high, Q7 is enabled. When OE = low, Q is held low, and Qb is held high for differential formats. For LVCMOS, both Q and Qb are held low when OE is set low. OE7 contains an internal pull-up resistor.
34	VDDOB	P	Output voltage supply—Bank B (Outputs Q5 through Q9) Bypass with 1.0 $\mu$ F capacitor and place as close to VDDOB pin as possible.
35	Q6b	O	Output clock 6 (complement)
36	Q6	O	Output clock 6
37	Q5b	O	Output clock 5 (complement)
38	Q5	O	Output clock 5

Pin #	Name	Type <sup>1</sup>	Description
39	CLK_SEL	I	MUX input select pin (LVCMOS) When CLK_SEL is high, CLK1 is selected When CLK_SEL is low, CLK0 is selected CLK_SEL contains an internal pull-down resistor
40	Q4b	O	Output clock 4 (complement)
41	Q4	O	Output clock 4
42	Q3b	O	Output clock 3 (complement)
43	Q3	O	Output clock 3
44	VDDOA	P	Output voltage supply—Bank A (Outputs Q0 to Q4) Bypass with 1.0 $\mu$ F capacitor and place as close to VDDOA pin as possible.
GND Pad	GND	GND	Ground Pad Power supply ground and thermal relief

**Note:**

1. Pin types are: I = input, O = output, P = power, GND = ground.

## 5.6 Si53306 Pin Descriptions

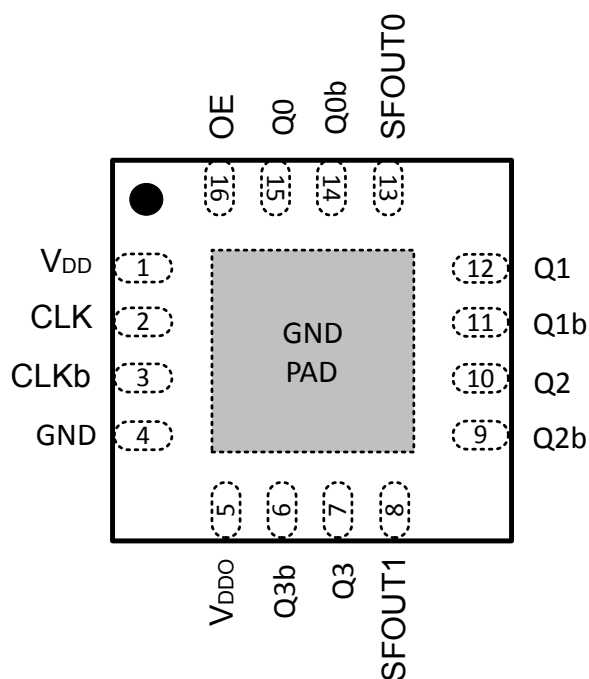


Table 5.6. Si53306 16-QFN Pin Descriptions

Pin	Name	Type <sup>1</sup>	Description
1	VDD	P	Core voltage supply. Bypass with 1.0 $\mu$ F capacitor and place as close to the VDD pin as possible.
2	CLK	I	Input clock.
3	CLKb	I	Input clock (complement). When the CLK is driven by a single-ended input, connect CLKb to VDD/2.
4	GND	GND	Ground.
5	VDDO	P	Output voltage supply— All outputs (Q0 to Q3). Bypass with 1.0 $\mu$ F capacitor and place as close to the VDDO pin as possible.
6	Q3b	O	Output clock 3 (complement).
7	Q3	O	Output clock 3.
8	SFOUT1	I	Output signal format control pin 1. Three-level input control. Internally biased at VDD/2. Can be left floating or tied to ground or VDD.
9	Q2b	O	Output clock 2 (complement).
10	Q2	O	Output clock 2.
11	Q1b	O	Output clock 1 (complement).
12	Q1	O	Output clock 1.

Pin	Name	Type <sup>1</sup>	Description
13	SFOUT0	I	Output signal format control pin 0. Three-level input control. Internally biased at VDD/2. Can be left floating or tied to ground or VDD.
14	Q0b	O	Output clock 0 (complement).
15	Q0	O	Output clock 0.
16	OE	I	Output enable. When OE = high, all outputs are enabled. When OE = low, Q is held low, and Qb is held high for differential formats. For LVCMOS, both Q and Qb are held low when OE is set low. OE contains an internal pull-up resistor.
GND Pad	GND	GND	Ground.

**Note:**

1. Pin types are: I = input, O = output, P = power, GND = ground.

## 5.7 Si53307 Pin Descriptions

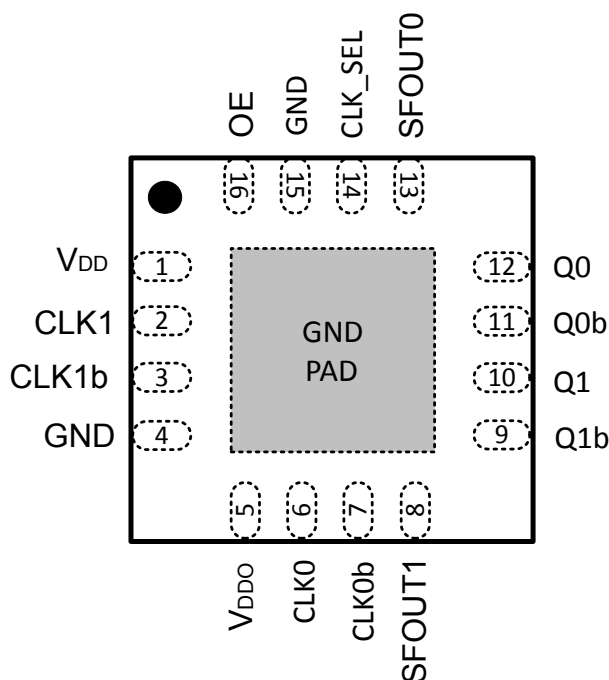


Table 5.7. Si53307 16-QFN Pin Descriptions

Pin	Name	Type <sup>1</sup>	Description
1	VDD	P	Core voltage supply. Bypass with 1.0 $\mu$ F capacitor and place as close to the VDD pin as possible.
2	CLK1	I	Input clock 1.
3	CLK1b	I	Input clock 1 (complement). When CLK1 is driven by a single-ended input, connect CLK1b to VDD/2.
4	GND	GND	Ground.
5	VDDO	P	Output clock supply voltage. Bypass with 1.0 $\mu$ F capacitor and place as close to the VDDO pin as possible.
6	CLK0	I	Input clock 0.
7	CLK0b	I	Input clock 0 (complement). When CLK0 is driven by a single-ended input, connect CLK0b to VDD/2.
8	SFOUT1	I	Output signal format control pin 1. Three-level input control. Internally biased at VDD/2. Can be left floating or tied to ground or VDD.
9	Q1b	O	Output clock 1 (complement).
10	Q1	O	Output clock 1.
11	Q0b	O	Output clock 0 (complement).
12	Q0	O	Output clock 0.

Pin	Name	Type <sup>1</sup>	Description
13	SFOUT0	I	Output signal format control pin 0. Three-level input control. Internally biased at VDD/2. Can be left floating or tied to ground or VDD.
14	CLK_SEL	I	Mux input select pin: When CLK_SEL is high, CLK1 is selected. When CLK_SEL is low, CLK0 is selected. CLK_SEL contains an internal pull-down resistor.
15	GND	GND	Ground.
16	OE	I	Output enable. When OE = high, all outputs are enabled. When OE = low, Q is held low, and Qb is held high for differential formats. For LVCMOS, both Q and Qb are held low when OE is set low. OE contains an internal pull-up resistor.
GND Pad	GND	GND	Ground.

**Note:**

1. Pin types are: I = input, O = output, P = power, GND = ground.

## 5.8 Si53308 Pin Descriptions

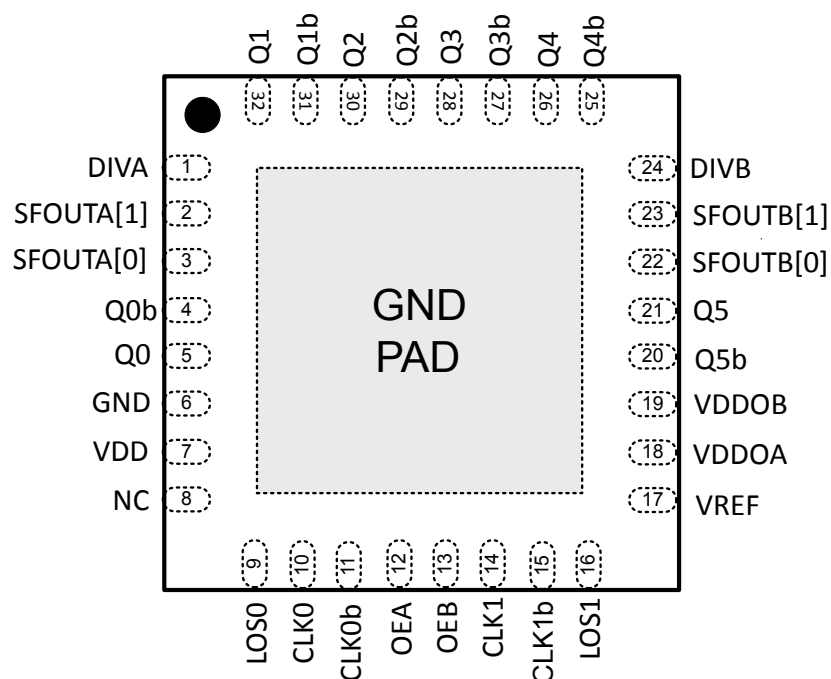


Table 5.8. Si53308 32-QFN Pin Descriptions

Pin	Name	Type <sup>1</sup>	Description
1	DIVA	I	Output divider control pin for Bank A. Three-level input control. Internally biased at VDD/2. Can be left floating or tied to ground or VDD.
2	SFOUTA[1]	I	Output signal format control pin 1 for Bank A. Three-level input control. Internally biased at VDD/2. Can be left floating or tied to ground or VDD.
3	SFOUTA[0]	I	Output signal format control pin 0 for Bank A. Three-level input control. Internally biased at VDD/2. Can be left floating or tied to ground or VDD.
4	Q0b	O	Output clock 0 (complement).
5	Q0	O	Output clock 0.
6	GND	GND	Ground.
7	VDD	P	Core voltage supply. Bypass with 1.0 $\mu$ F capacitor and place close to the VDD pin as possible.
8	NC		No connect.
9	LOS0	O	The LOS0 status pin indicates whether a clock is present (LOS0 = 0) or not present (LOS0 = 1) at the CLK0 input.
10	CLK0	I	Input clock 0.
11	CLK0b	I	Input clock 0 (complement). When CLK0 is driven by a single-ended input, connect CLK0b to VDD/2.

Pin	Name	Type <sup>1</sup>	Description
12	OEA	I	Output enable—Bank A. When OE = high, the Bank A outputs are enabled. When OE = low, Q is held low and Qb is held high for differential formats. For LVCMOS, both Q and Qb are held low when OE is set low. OEA contains an internal pull-up resistor.
13	OEB	I	Output enable—Bank B. When OE = high, the Bank B outputs are enabled. When OE = low, Q is held low and Qb is held high for differential formats. For LVCMOS, both Q and Qb are held low when OE is set low. OEB contains an internal pull-up resistor.
14	CLK1	I	Input clock 1.
15	CLK1b	I	Input clock 1 (complement). When CLK1 is driven by a single-ended input, connect CLK1b to VDD/2.
16	LOS1	O	The LOS1 status pin indicates whether a clock is present (LOS1 = 0) or not present (LOS1 = 1) at the CLK1 input.
17	VREF	O	Reference voltage.
18	VDDOA	P	Output Clock Voltage Supply—Bank A (Outputs: Q0 to Q2). Bypass with 1.0 $\mu$ F capacitor and place as close to the VDDOA pin as possible.
19	VDDOB	P	Output Clock Voltage Supply—Bank B (Outputs: Q3 to Q5). Bypass with 1.0 $\mu$ F capacitor and place as close to the VDDOB pin as possible.
20	Q5b	O	Output clock 5 (complement).
21	Q5	O	Output clock 5.
22	SFOUTB[0]	I	Output signal format control pin 0 for Bank B. Three-level input control. Internally biased at VDD/2. Can be left floating or tied to ground or VDD.
23	SFOUTB[1]	I	Output signal format control pin 1 or Bank B. Three-level input control. Internally biased at VDD/2. Can be left floating or tied to ground or VDD.
24	DIVB	I	Output divider control pin for Bank B. Three-level input control. Internally biased at VDD/2. Can be left floating or tied to ground or VDD.
25	Q4b	O	Output clock 4 (complement).
26	Q4	O	Output clock 4.
27	Q3b	O	Output clock 3 (complement).
28	Q3	O	Output clock 3.
29	Q2b	O	Output clock 2 (complement).



Pin	Name	Type <sup>1</sup>	Description
30	Q2	O	Output clock 2.
31	Q1b	O	Output clock 1 (complement).
32	Q1	O	Output clock 1.
GND Pad	GND	GND	Ground Pad. Power supply ground and thermal relief.

**Note:**

1. Pin types are: I = input, O = output, P = power, GND = ground.

## 6. Package Outlines

### 6.1 16-QFN Package Diagram

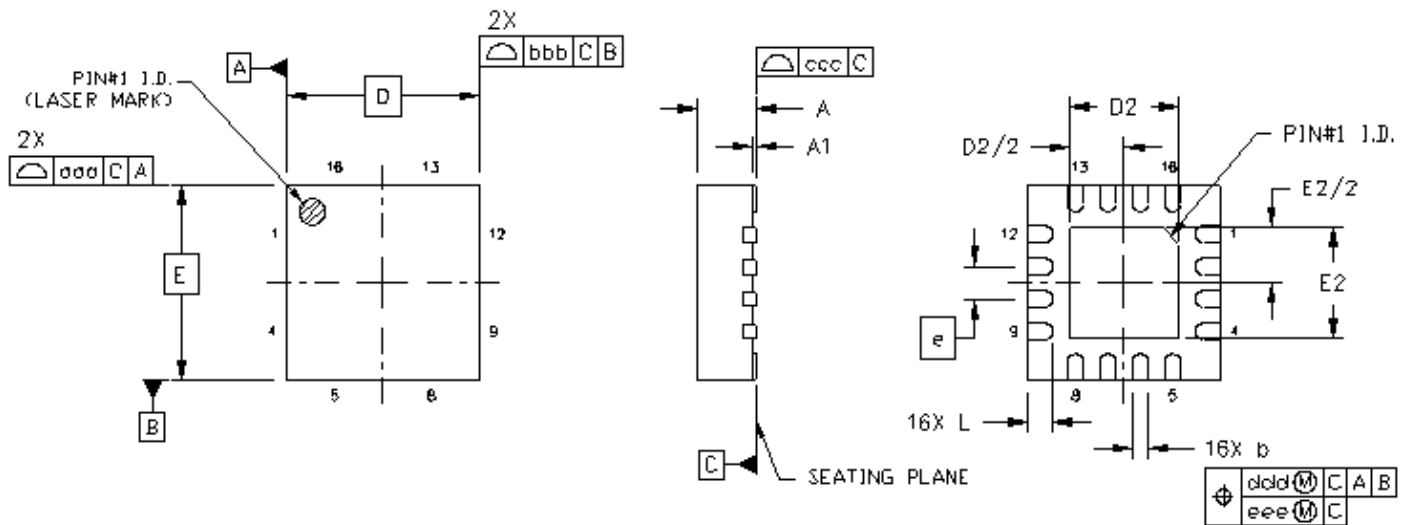


Figure 6.1. 3x3 mm 16-QFN Package Diagram Dimensions

Table 6.1. Package Diagram Dimensions

Dimension	Min	Nom	Max
A	0.80	0.85	0.90
A1	0.00	0.02	0.05
b	0.18	0.25	0.30
D	3.00 BSC		
D2	1.70	1.80	1.90
e	0.50 BSC		
E	3.00 BSC		
E2	1.70	1.80	1.90
L	0.30	0.40	0.50
aaa	—	—	0.10
bbb	—	—	0.10
ccc	—	—	0.08
ddd	—	—	0.10
eee	—	—	0.05

#### Notes:

1. All dimensions shown are in millimeters (mm) unless otherwise noted.
2. Dimensioning and Tolerancing per ANSI Y14.5M-1994.

## 6.2 32-QFN Package Diagram

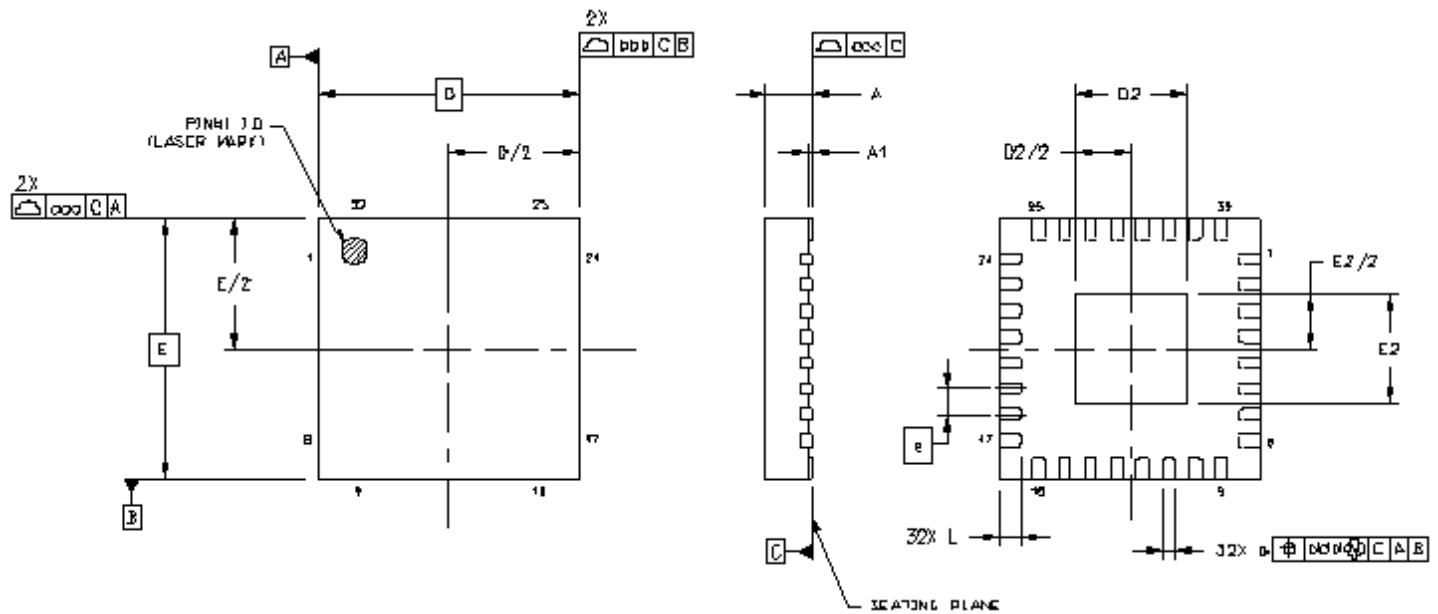


Figure 6.2. 5x5 mm 32-QFN Package Diagram Dimensions

Table 6.2. Package Diagram Dimensions

Dimension	Min	Nom	Max
A	0.80	0.85	1.00
A1	0.00	0.02	0.05
b	0.18	0.25	0.30
c	0.20	0.25	0.30
D	5.00 BSC		
D2	2.00	2.15	2.30
e	0.50 BSC		
E	5.00 BSC		
E2	2.00	2.15	2.30
L	0.30	0.40	0.50
aaa	0.10		
bbb	0.10		
ccc	0.08		
ddd	0.10		

**Notes:**

1. All dimensions shown are in millimeters (mm) unless otherwise noted.
2. Dimensioning and Tolerancing per ANSI Y14.5M-1994.
3. This drawing conforms to the JEDEC Solid State Outline MO-220.

## 6.3 44-QFN Package Diagram

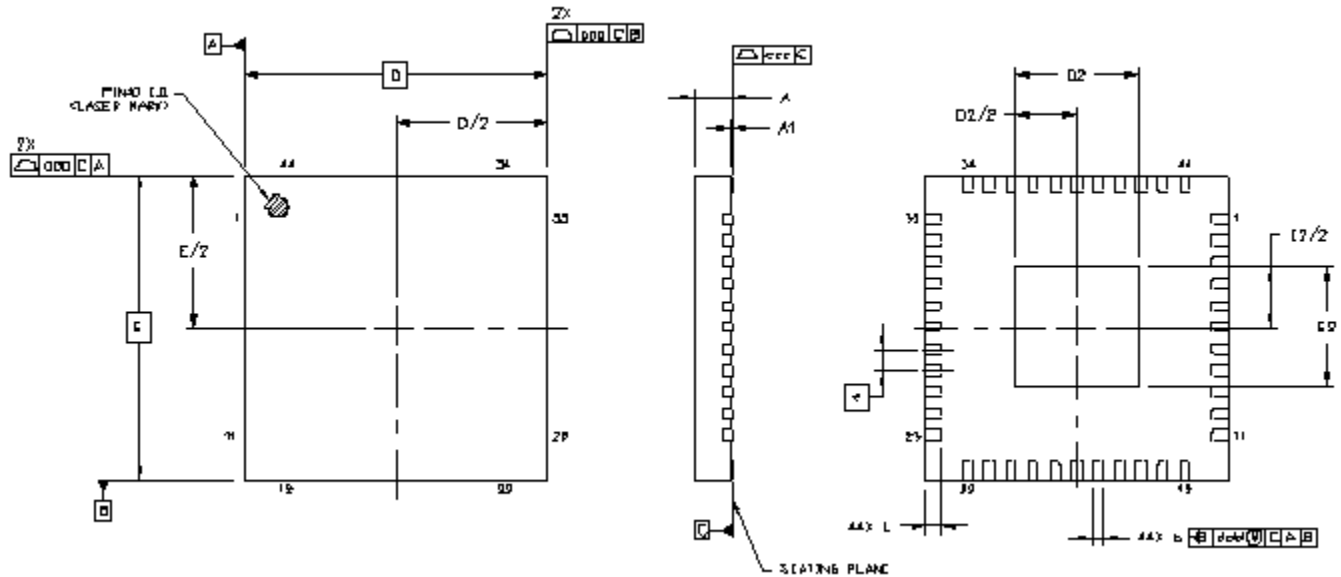


Figure 6.3. 7x7 mm 44-QFN Package Diagram Dimensions

Table 6.3. Package Diagram Dimensions

Dimension	Min	Nom	Max
A	0.80	0.85	0.90
A1	0.00	0.02	0.05
b	0.18	0.25	0.30
D	7.00 BSC		
D2	2.65	2.80	2.95
e	0.50 BSC		
E	7.00 BSC		
E2	2.65	2.80	2.95
L	0.30	0.40	0.50
aaa	—	—	0.10
bbb	—	—	0.10
ccc	—	—	0.08
ddd	—	—	0.10

**Notes:**

1. All dimensions shown are in millimeters (mm) unless otherwise noted.
2. Dimensioning and Tolerancing per ANSI Y14.5M-1994.
3. This drawing conforms to the JEDEC Solid State Outline MO-220.
4. Recommended card reflow profile is per the JEDEC/IPC J-STD-020 specification for Small Body Components.

## 7. Land Patterns

### 7.1 16-QFN Land Pattern

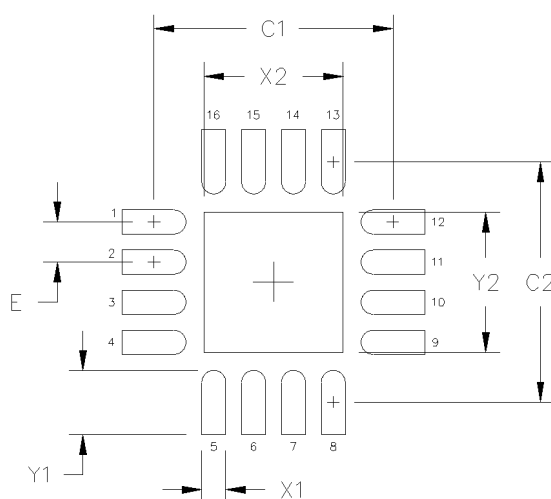


Figure 7.1. 3x3 mm 16-QFN Land Pattern

Table 7.1. PCB Land Pattern

Dimension	mm
C1	3.00
C2	3.00
E	0.50
X1	0.30
Y1	0.80
X2	1.80
Y2	1.80

#### Notes:

##### General

1. All dimensions shown are in millimeters (mm).
2. This Land Pattern Design is based on the IPC-7351 guidelines.
3. All dimensions shown are at Maximum Material Condition (MMC). Least Material Condition (LMC) is calculated based on a Fabrication Allowance of 0.05 mm.

##### Solder Mask Design

1. All metal pads are to be non-solder mask defined (NSMD). Clearance between the solder mask and the metal pad is to be 60µm minimum, all the way around the pad.

##### Stencil Design

1. A stainless steel, laser-cut and electro-polished stencil with trapezoidal walls should be used to assure good solder paste release.
2. The stencil thickness should be 0.125 mm (5 mils).
3. The ratio of stencil aperture to land pad size should be 1:1 for all perimeter pads.
4. A 2 x 2 array of 0.65 mm square openings on a 0.90 mm pitch should be used for the center ground pad.

##### Card Assembly

1. A No-Clean, Type-3 solder paste is recommended.
2. The recommended card reflow profile is per the JEDEC/IPC J-STD-020 specification for Small Body Components.

## 7.2 32-QFN Land Pattern

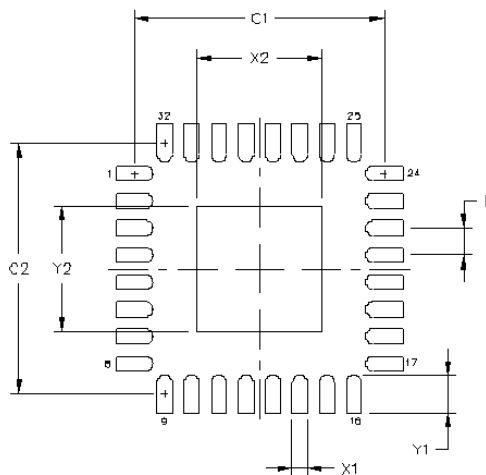


Figure 7.2. 5x5 mm 32-QFN Land Pattern

Table 7.2. PCB Land Pattern

Dimension	Min	Max
C1	4.52	4.62
C2	4.52	4.62
E	0.50 BSC	
X1	0.20	0.30
X2	2.20	2.30
Y1	0.59	0.69
Y2	2.20	2.30

**Notes:****General**

1. All dimensions shown are in millimeters (mm) unless otherwise noted.
2. This Land Pattern Design is based on the IPC-7351 guidelines.

**Solder Mask Design**

1. All metal pads are to be non-solder mask defined (NSMD). Clearance between the solder mask and the metal pad is to be 60  $\mu\text{m}$  minimum, all the way around the pad.

**Stencil Design**

1. A stainless steel, laser-cut and electro-polished stencil with trapezoidal walls should be used to assure good solder paste release.
2. The stencil thickness should be 0.125 mm (5 mils).
3. The ratio of stencil aperture to land pad size should be 1:1 for all perimeter pads.
4. A 2x2 array of 0.75 mm square openings on 1.15 mm pitch should be used for the center ground pad.

**Card Assembly**

1. A No-Clean, Type-3 solder paste is recommended.
2. The recommended card reflow profile is per the JEDEC/IPC J-STD-020 specification for Small Body Components.

## 7.3 44-QFN Land Pattern

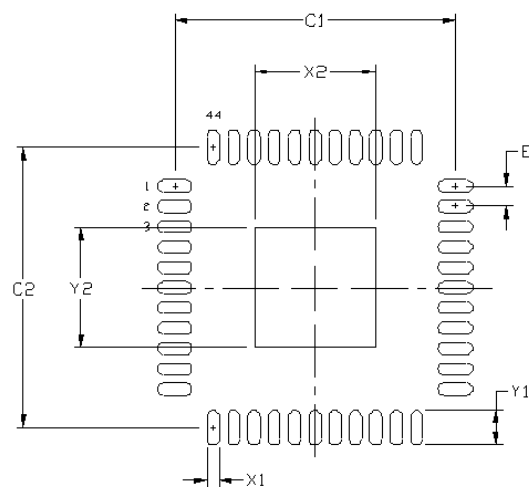


Figure 7.3. 7x7 mm 44-QFN Land Pattern

Table 7.3. PCB Land Pattern

Dimension	Min	Max
C1	6.80	6.90
C2	6.80	6.90
E	0.50 BSC	
X1	0.20	0.30
X2	2.85	2.95
Y1	0.75	0.85
Y2	2.85	2.95

**Notes:****General**

1. All dimensions shown are in millimeters (mm) unless otherwise noted.
2. This Land Pattern Design is based on the IPC-7351 guidelines.

**Solder Mask Design**

1. All metal pads are to be non-solder mask defined (NSMD). Clearance between the solder mask and the metal pad is to be 60  $\mu\text{m}$  minimum, all the way around the pad.

**Stencil Design**

1. A stainless steel, laser-cut and electro-polished stencil with trapezoidal walls should be used to assure good solder paste release.
2. The stencil thickness should be 0.125 mm (5 mils).
3. The ratio of stencil aperture to land pad size should be 1:1 for all perimeter pads.
4. A 2x2 array of 1.0 mm square openings on 1.45 mm pitch should be used for the center ground pad.

**Card Assembly**

1. A No-Clean, Type-3 solder paste is recommended.
2. The recommended card reflow profile is per the JEDEC/IPC J-STD-020 specification for Small Body Components.

## 8. Top Markings

### 8.1 Si53301/04/08 Top Markings

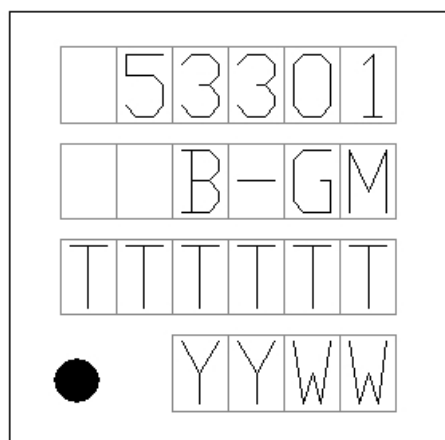


Figure 8.1. Si53301 Top Marking

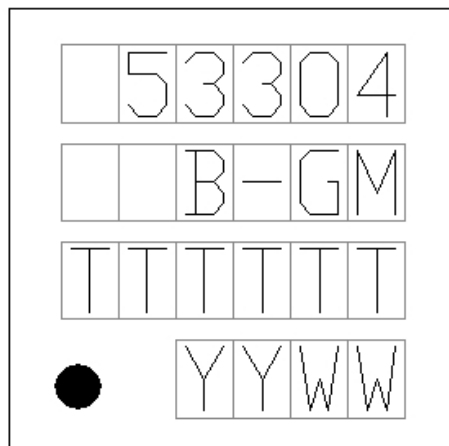


Figure 8.2. Si53304 Top Marking

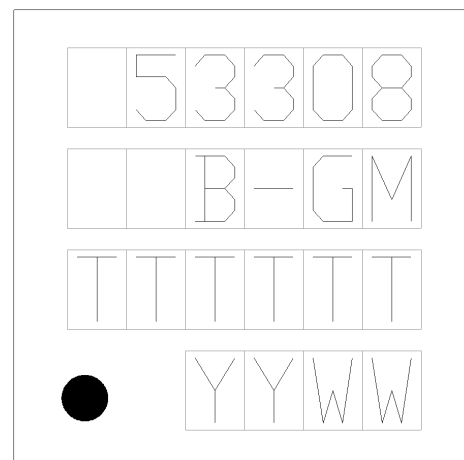


Figure 8.3. Si53308 Top Marking

Table 8.1. Si53301/04/08 32-QFN Top Marking Explanation

<b>Mark Method:</b>	Laser	
<b>Font Size:</b>	2.0 Point (28 mils) Center-Justified	
<b>Line 1 Marking:</b>	Device Part Number	53301 for Si53301-B-GM 53304 for Si53304-B-GM 53308 for Si53308-B-GM
<b>Line 2 Marking:</b>	Device Revision/Type	B-GM
<b>Line 3 Marking:</b>	TTTTTT = Mfg Code	Manufacturing Code
<b>Line 4 Marking</b>	Circle = 0.5 mm Diameter Lower-Left Justified	Pin 1 Identifier
	YY = Year WW = Work Week	Assigned by Assembly Supplier. Corresponds to the year and work week of the mold date.



## 8.2 Si53302/03/05 Top Markings



Figure 8.4. Si53302 Top Marking

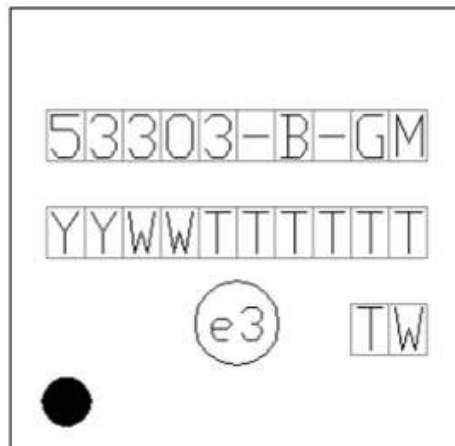


Figure 8.5. Si53303 Top Marking



Figure 8.6. Si53305 Top Marking

Table 8.2. Si53302/03/05 44-QFN Top Marking Explanation

<b>Mark Method:</b>	Laser	
<b>Font Size:</b>	1.9 Point (26 mils) Right-Justified	
<b>Line 1 Marking:</b>	Device Part Number	53302 for Si53302-B-GM 53303 for Si53303-B-GM 53305 for Si53305-B-GM
<b>Line 2 Marking:</b>	YY = Year WW=Work Week	Assigned by Assembly Supplier. Corresponds to the year and work week of the mold date.
	TTTTTT = Mfg Code	Manufacturing Code from the Assembly Purchase Order form.
<b>Line 3 Marking:</b>	Circle=1.3 mm Diameter Center-Justified	"e3" Pb-Free Symbol
	Country of Origin ISO Code Abbreviation	TW
<b>Line 4 Marking</b>	Circle = 0.75 mm Diameter Filled	Pin 1 Identification

## 8.3 Si53306/07 Top Markings

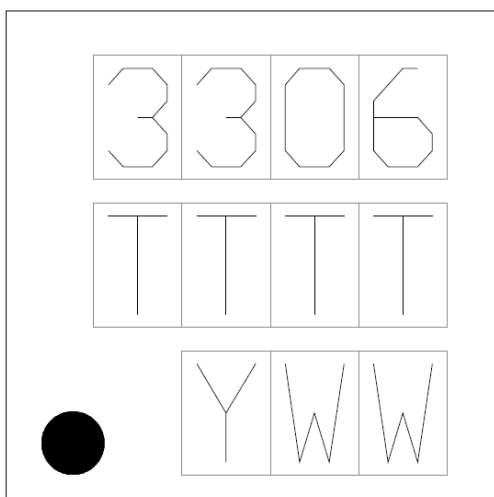


Figure 8.7. Si53306 Top Marking

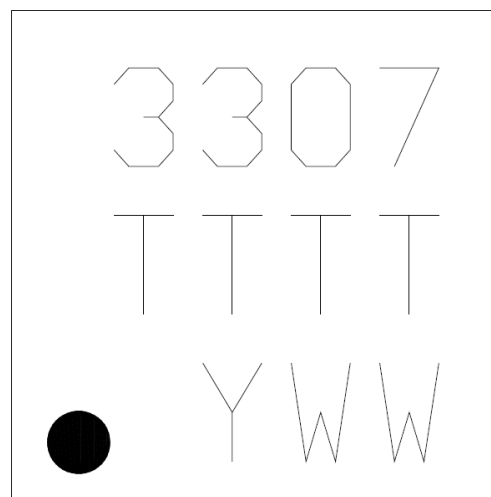


Figure 8.8. Si53307 Top Marking

Table 8.3. Si53306/07 Top Marking Explanation

<b>Mark Method:</b>	Laser	
<b>Font Size:</b>	0.635 mm (25 mils) Right-Justified	
<b>Line 1 Marking:</b>	Device Part Number	3306 for Si53306-B-GM 3307 for Si53307-B-GM
<b>Line 2 Marking:</b>	TTTT = Mfg Code	Manufacturing Code from the Assembly Purchase Order form.
	YY = Year WW=Work Week	Assigned by Assembly Supplier. Corresponds to the year and work week of the mold date.
<b>Line 3 Marking:</b>	Circle=0.5 mm Diameter (Bottom-Left Justified)	Pin 1 Identifier
	YWW = Date Code	Corresponds to the last digit of the current year (Y) and the workweek (WW) of the mold date.

## 9. Revision History

### Revision 1.0

April, 2019

Initial release.



## ClockBuilder Pro

One-click access to Timing tools, documentation, software, source code libraries & more. Available for Windows and iOS (CBGo only).

[www.silabs.com/CBPro](http://www.silabs.com/CBPro)



**Timing Portfolio**  
[www.silabs.com/timing](http://www.silabs.com/timing)



**SW/HW**  
[www.silabs.com/CBPro](http://www.silabs.com/CBPro)



**Quality**  
[www.silabs.com/quality](http://www.silabs.com/quality)



**Support and Community**  
[community.silabs.com](http://community.silabs.com)

### Disclaimer

Silicon Labs intends to provide customers with the latest, accurate, and in-depth documentation of all peripherals and modules available for system and software implementers using or intending to use the Silicon Labs products. Characterization data, available modules and peripherals, memory sizes and memory addresses refer to each specific device, and "Typical" parameters provided can and do vary in different applications. Application examples described herein are for illustrative purposes only. Silicon Labs reserves the right to make changes without further notice to the product information, specifications, and descriptions herein, and does not give warranties as to the accuracy or completeness of the included information. Without prior notification, Silicon Labs may update product firmware during the manufacturing process for security or reliability reasons. Such changes will not alter the specifications or the performance of the product. Silicon Labs shall have no liability for the consequences of use of the information supplied in this document. This document does not imply or expressly grant any license to design or fabricate any integrated circuits. The products are not designed or authorized to be used within any FDA Class III devices, applications for which FDA premarket approval is required or Life Support Systems without the specific written consent of Silicon Labs. A "Life Support System" is any product or system intended to support or sustain life and/or health, which, if it fails, can be reasonably expected to result in significant personal injury or death. Silicon Labs products are not designed or authorized for military applications. Silicon Labs products shall under no circumstances be used in weapons of mass destruction including (but not limited to) nuclear, biological or chemical weapons, or missiles capable of delivering such weapons. Silicon Labs disclaims all express and implied warranties and shall not be responsible or liable for any injuries or damages related to use of a Silicon Labs product in such unauthorized applications.

### Trademark Information

Silicon Laboratories Inc.®, Silicon Laboratories®, Silicon Labs®, SiLabs® and the Silicon Labs logo®, Bluegiga®, Bluegiga Logo®, Clockbuilder®, CMEMS®, DSPLL®, EFM®, EFM32®, EFR®, Ember®, Energy Micro, Energy Micro logo and combinations thereof, "the world's most energy friendly microcontrollers", Ember®, EZLink®, EZRadio®, EZRadioPRO®, Gecko®, Gecko OS, Gecko OS Studio, ISOmodem®, Precision32®, ProSLIC®, Simplicity Studio®, SiPHY®, Telegesis, the Telegesis Logo®, USBXpress®, Zentri, the Zentri logo and Zentri DMS, Z-Wave®, and others are trademarks or registered trademarks of Silicon Labs. ARM, CORTEX, Cortex-M3 and THUMB are trademarks or registered trademarks of ARM Holdings. Keil is a registered trademark of ARM Limited. Wi-Fi is a registered trademark of the Wi-Fi Alliance. All other products or brand names mentioned herein are trademarks of their respective holders.



Silicon Laboratories Inc.  
400 West Cesar Chavez  
Austin, TX 78701  
USA

<http://www.silabs.com>

## Данный компонент на территории Российской Федерации

### Вы можете приобрести в компании MosChip.

Для оперативного оформления запроса Вам необходимо перейти по данной ссылке:

<http://moschip.ru/get-element>

Вы можете разместить у нас заказ для любого Вашего проекта, будь то серийное производство или разработка единичного прибора.

В нашем ассортименте представлены ведущие мировые производители активных и пассивных электронных компонентов.

Нашей специализацией является поставка электронной компонентной базы двойного назначения, продукции таких производителей как XILINX, Intel (ex.ALTERA), Vicor, Microchip, Texas Instruments, Analog Devices, Mini-Circuits, Amphenol, Glenair.

Сотрудничество с глобальными дистрибьюторами электронных компонентов, предоставляет возможность заказывать и получать с международных складов практически любой перечень компонентов в оптимальные для Вас сроки.

На всех этапах разработки и производства наши партнеры могут получить квалифицированную поддержку опытных инженеров.

Система менеджмента качества компании отвечает требованиям в соответствии с ГОСТ Р ИСО 9001, ГОСТ РВ 0015-002 и ЭС РД 009

### Офис по работе с юридическими лицами:

105318, г.Москва, ул.Щербаковская д.3, офис 1107, 1118, ДЦ «Щербаковский»

Телефон: +7 495 668-12-70 (многоканальный)

Факс: +7 495 668-12-70 (доб.304)

E-mail: [info@moschip.ru](mailto:info@moschip.ru)

Skype отдела продаж:

moschip.ru

moschip.ru\_4

moschip.ru\_6

moschip.ru\_9