

PET1600-12-074NA

AC-DC Front-End Power Supply

The PET1600-12-074NA is a 1600 Watt AC to DC, power-factor-corrected (PFC) power supply that converts standard AC power into a main output of +12 VDC for powering intermediate bus architectures (IBA) in high performance and reliability servers, routers, and network switches.

The PET1600-12-074NA utilizes full digital control architecture for greater efficiency, control, and functionality.

This power supply meets international safety standards and displays the CE-Mark for the European Low Voltage Directive (LVD).



Key Features & Benefits

- Best-in-Class, 80 PLUS Certified “Platinum” Efficiency
- Auto-Selected Input Voltage Ranges: 90-140VAC, 180-264 VAC
- AC Input with Power Factor Correction
- 1600 W Continuous and 2100 W Peak Output Power Capability
- Always-On 12 V/3.5 A Standby Output
- Hot-plug Capable
- Parallel Operation with Active Current Sharing
- Full Digital Controls for Improved Performance
- High Density Design: 33.7 W/in³
- Small Form Factor: 265 x 73.5 x 40 mm (10.43 x 2.89 x 1.57 in)
- Power Management Bus Communication Protocol for Control Programming and Monitoring
- Status LED with Fault Signaling

Applications

- Networking Switches
- Servers & Routers
- Telecommunications



bel POWER
SOLUTIONS &
PROTECTION

a bel group

belfuse.com/power-solutions

1. ORDERING INFORMATION

PET	1600	-	12	-	074	N	A
Product Family	Power Level	Dash	V1 Output	Dash	Width	Airflow	Input
PET Front-Ends	1600 W		12 V		74 mm	N: Normal	A: AC

2. OVERVIEW

The PET1600-12-074NA AC/DC power supply is a fully DSP controlled, highly efficient front-end power supply. It incorporates resonance-soft-switching technology to reduce component stresses, providing increased system reliability and very high efficiency. With a wide input operational voltage range the PET1600-12-074NA maximizes power availability in demanding server, network, and other high availability applications. The supply is fan cooled and ideally suited for integration with a matching airflow path. The PFC stage is digitally controlled using a state-of-the-art digital signal processing algorithm to guarantee best efficiency and unity power factor over a wide operating range. The DC/DC stage uses soft switching resonant techniques in conjunction with synchronous rectification. An active OR-ing device on the output ensures no reverse load current and renders the supply suitable for operation in redundant power systems. The always-on standby output provides power to external power distribution and management controllers. It is protected with an active OR-ing device for maximum reliability. Status information is provided with a front-panel LED. In addition, the power supply can be controlled and the fan speed set via the I2C bus. The I2C bus allows full monitoring of the supply, including input and output voltage, current, power, and inside temperatures. Cooling is managed by a fan controlled by the DSP controller. The fan speed is adjusted automatically depending on the actual power demand and supply temperature and can be overridden through the I2C bus.

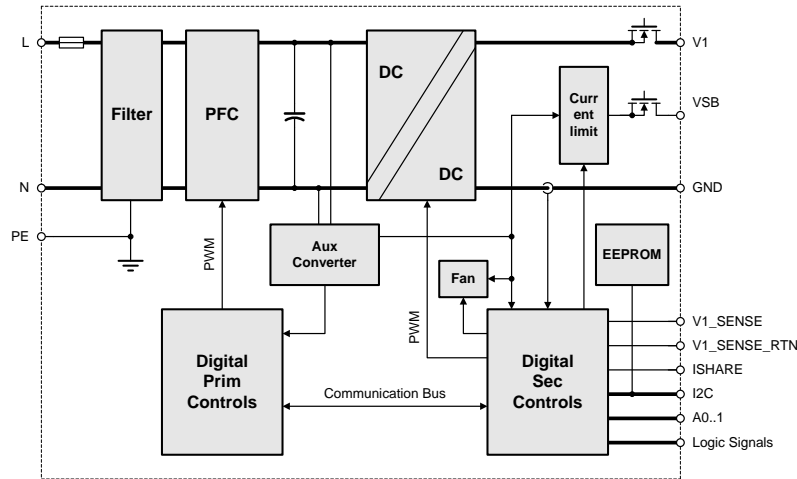

Figure 1. PET1600-12-074NA Block Diagram

3. ABSOLUTE MAXIMUM RATINGS

Stresses in excess of the absolute maximum ratings may cause performance degradation, adversely affect long-term reliability and cause permanent damage to the supply.

PARAMETER	CONDITIONS / DESCRIPTION	MIN	MAX	UNITS
$V_i\ maxc$	Maximum Input		264	VAC

4. INPUT

General Condition: $T_A = 0 \dots 55 \text{ }^\circ\text{C}$, $V_i = 230 \text{ VAC}$ unless otherwise noted.

PARAMETER	DESCRIPTION / CONDITION	MIN	NOM	MAX	UNIT	
$V_{i,nom}$	Nominal Input Voltage	Rated Voltage High Line ($V_{i,nom HL}$)	200	230	240	VAC
		Rated Voltage Low Line ($V_{i,nom LL}$)	100	115	127	VAC
V_i	Input Voltage Ranges	Normal operating ($V_{i,min HL}$ to $V_{i,max HL}$), High Line	180		264	VAC
		Normal operating ($V_{i,min LL}$ to $V_{i,max LL}$), Low Line	90		140	VAC
$I_{i,max}$	Maximum Input Current	$V_{IN} = 100 \text{ VAC}$, 100% load			13	A _{RMS}
$I_{i,inrush}$	Inrush Current Limitation	$V_{i,min}$ to $V_{i,max}$, $T_{NTC} = 25^\circ\text{C}$, 5 ms			10	A _p
f_i	Input Frequency	47	50/60	63	Hz	
PF	Power Factor	10% Load	0.8	0.88		W/VA
		20% Load	0.9	0.95		W/VA
		50% Load	0.9	0.997		W/VA
		100% Load	0.95	0.999		W/VA
THD	Total Harmonic Distortion	TBD			TBD	%
$V_{i,on}$	Turn-on Input Voltage ¹	Ramping up		87	90	VAC
$V_{i,off}$	Turn-off Input Voltage ¹	Ramping down		82	87	VAC
η	Efficiency ²	$V_{IN} = 230 \text{ VAC}$, 10% load	82	90.8		%
		$V_{IN} = 230 \text{ VAC}$, 20% load	90	93.5		%
		$V_{IN} = 230 \text{ VAC}$, 50% load	94	94.4		%
		$V_{IN} = 230 \text{ VAC}$, 100% load	91	93.0		%
$T_{V1 holdup}$	Hold-up Time V_i	$V_{IN} = 230 \text{ VAC}$, 50% load		20		ms
		$V_{IN} = 230 \text{ VAC}$, 75% load		13		ms
		$V_{IN} = 230 \text{ VAC}$, 100% load		9		ms
		$V_{IN} = 110 \text{ VAC}$, 100% load		17		ms
$T_{VSB holdup}$	Hold-up Time V_{SB}	12 V_{SB} , full load		70		ms

4.1 INPUT FUSE

Time-lag 16 A input fuse (5 x 20 mm) in series with the L-line inside the power supply protects against severe defects. The fuse is not accessible from the outside and is therefore not a serviceable part.

4.2 INRUSH CURRENT

The AC-DC power supply exhibits an X capacitance of only 5.9 μF , resulting in a low and short peak current, when the supply is connected to the mains. The internal bulk capacitor will be charged through an NTC which will limit the inrush current.

NOTE:

Do not repeat plug-in / out operations within a short time, or else the internal in-rush current limiting device (NTC) may not sufficiently cool down and excessive inrush current or component failure(s) may result.

¹ The Front-End is provided with a minimum hysteresis of 3 V during turn-on and turn-off within the ranges

² Efficiency measured without fan power per EPA server guidelines



4.3 INPUT UNDER-VOLTAGE

If the sinusoidal input voltage stays below the input under voltage lockout threshold V_i on, the supply will be inhibited. Once the input voltage returns within the normal operating range, the supply will return to normal operation again.

4.4 POWER FACTOR CORRECTION

Power factor correction (PFC) is achieved by controlling the input current waveform synchronously with the input voltage. A fully digital controller is implemented giving outstanding PFC results over a wide input voltage and load ranges. The input current will follow the shape of the input voltage. If for instance the input voltage has a trapezoidal waveform, then the current will also show a trapezoidal waveform.

4.5 EFFICIENCY

High efficiency (see [Figure 2](#)) is achieved by using state-of-the-art silicon power devices in conjunction with soft-transition topologies minimizing switching losses and a full digital control scheme. Synchronous rectifiers on the output reduce the losses in the high current output path. The speed of the fan is digitally controlled to keep all components at an optimal operating temperature regardless of the ambient temperature and load conditions.

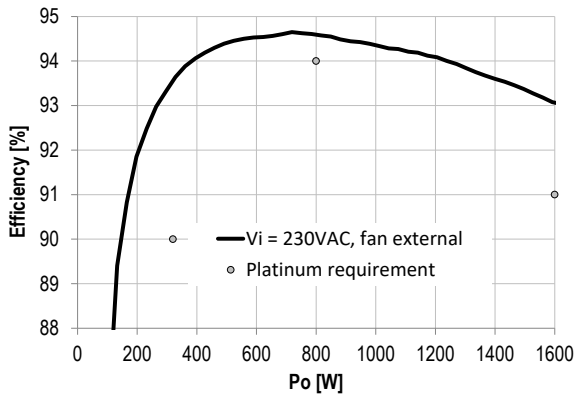

Figure 2. Efficiency vs. Load current (ratio metric loading)

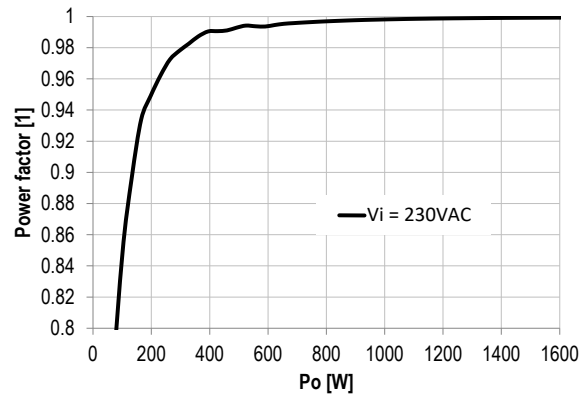

Figure 3. Power factor vs. Load current

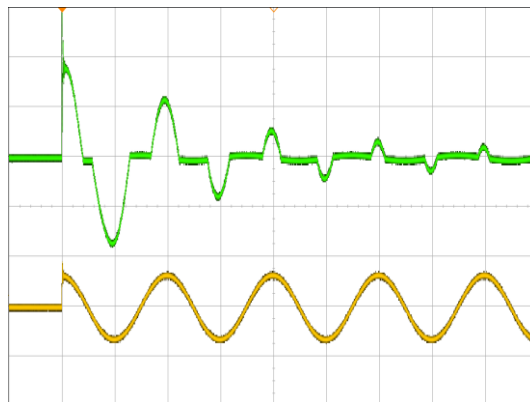

Figure 4. Inrush current, $V_{in} = 230 \text{ Vac}$, 90°
 CH1: V_{in} (500 V/div), CH2: I_{in} (10 A/div)

5. OUTPUT

5.1 MAIN OUTPUT V_1

General Condition: $T_A = 0 \dots 55 \text{ }^\circ\text{C}$, $V_i = 230 \text{ VAC}$ unless otherwise noted.

PARAMETER	DESCRIPTION / CONDITION	MIN	NOM	MAX	UNIT	
$V_{1 \text{ nom}}$	Nominal Output Voltage		12.0		VDC	
$V_{1 \text{ set}}$	Output Setpoint Accuracy	$0.5 I_{1 \text{ nom}}$, $T_A = 25^\circ\text{C}$				
$dV_{1 \text{ tot}}$	Static Regulation	$V_{1 \text{ min}}$ to $V_{1 \text{ max}}$, 0 to 100% $I_{1 \text{ nom}}$	-1	+1	% $V_{1 \text{ nom}}$	
$P_{1 \text{ nom}}$	Nominal Output Power	$V_{1 \text{ min HL}}$ to $V_{1 \text{ max HL}}$		1600	W	
		$V_{1 \text{ min LL}}$ to $V_{1 \text{ max LL}}$		1000	W	
$P_{1 \text{ peak}}$	Peak Output Power ³	$V_{1 \text{ min HL}}$ to $V_{1 \text{ max HL}}$		2100	W	
		$V_{1 \text{ min LL}}$ to $V_{1 \text{ max LL}}$		1320	W	
$I_{1 \text{ nom}}$	Output Current	$V_{1 \text{ min HL}}$ to $V_{1 \text{ max HL}}$	0.0	133	ADC	
$I_{1 \text{ nom red}}$		$V_{1 \text{ min LL}}$ to $V_{1 \text{ max LL}}$	0.0	83	ADC	
$I_{1 \text{ peak}}$	Peak Output Current ³	$V_{1 \text{ min HL}}$ to $V_{1 \text{ max HL}}$	0.0	175	ADC	
$I_{1 \text{ peak red}}$		$V_{1 \text{ min LL}}$ to $V_{1 \text{ max LL}}$	0.0	110	ADC	
$V_{1 \text{ pp}}$	Output Ripple Voltage ⁴	$V_{1 \text{ min}}$ to $V_{1 \text{ max}}$, 0 to 75% $I_{1 \text{ nom}}$, $C_{\text{ext}} = 0 \text{ mF}$		120	mVpp	
		$V_{1 \text{ min}}$ to $V_{1 \text{ max}}$, 75 to 100% $I_{1 \text{ nom}}$, $C_{\text{ext}} = 0 \text{ mF}$		150	mVpp	
		$V_{1 \text{ min LL}}$ to $V_{1 \text{ max HL}}$, 0 to 100% $I_{1 \text{ nom}}$, $C_{\text{ext}} \geq 1 \text{ mF/Low ESR}$		120	mVpp	
$dV_{1 \text{ load}}$	Load Regulation	$V_{1 \text{ nom HL}}$, 0 to 100% $I_{1 \text{ nom}}$	-67	-89	-111	mV
$dV_{1 \text{ line}}$	Line Regulation	$V_{1 \text{ min}}$ to $V_{1 \text{ max}}$, $0.5 \cdot I_{1 \text{ nom}}$	-24	0	24	mV
$dV_{1 \text{ temp}}$	Thermal Drift	$0.5 \cdot I_{1 \text{ nom}}$, $T_A = 0 \dots 55^\circ\text{C}$			TBD	%/ $^\circ\text{C}$
$dI_{1 \text{ share}}$	Current Sharing	Difference between individual I_1 , 0 ... 8 power supplies in parallel	-8		+8	ADC
V_{SHARE}	Current Share Bus Voltage	$I_{1 \text{ peak}}$		9.14		VDC
$dV_{1 \text{ lt}}$	Load Transient Response	$\Delta I_1 = 50\% I_{1 \text{ nom}}$, $I_1 = 5 \dots 100\% I_{1 \text{ nom}}$, $C_{\text{ext}} = 0 \text{ mF}$		0.35	0.6	VDC
$dV_{1 \text{ lt}}$		$\Delta I_1 = 10\% I_{1 \text{ nom}}$, $I_1 = 0 \dots 10\% I_{1 \text{ nom}}$, $C_{\text{ext}} = 0 \text{ mF}$		0.35	0.6	VDC
t_{rec}	Recovery Time	$dI/dt = 1 \text{ A}/\mu\text{s}$, recovery within 1% of $V_{1 \text{ nom}}$		0.5	1	ms
$V_{1 \text{ dyn}}$	Dynamic Load Regulation	$\Delta I_1 = 60\% I_{1 \text{ nom}}$, $I_1 = 5 \dots 133 \text{ A}$, $f = 50 \dots 5000 \text{ Hz}$, Duty cycle = 10 ... 90%, $C_{\text{ext}} = 2 \dots 30 \text{ mF}$	11.4		12.6	V
$t_{V1 \text{ rise}}$	Output Voltage Rise Time	$I_1 = 10 \dots 90\% I_{1 \text{ nom}}$, external capacitance < 10 mF	0.5		30	ms
$t_{V1 \text{ ovr sh}}$	Output Turn-on Overshoot	$V_{1 \text{ nom HL}}$, 0 to 100% $I_{1 \text{ nom}}$			12.6	V
$dV_{1 \text{ sense}}$	Remote Sense	Compensation for cable drop, 0 to 100% $I_{1 \text{ nom}}$			0.25	V
$C_{V1 \text{ load}}$	Capacitive Loading		0		25	mF

³ Peak combined power for all outputs does not exceed 2100 W; maximum of peak power duration is 20 seconds without asserting the SMB Alert signal.

⁴ Measured with a 10 μF low ESR capacitor in parallel with a 0.1 μF ceramic capacitor at the point of measurement.

5.2 STANBY OUTPUT V_{SB}

General Condition: $T_A = 0 \dots 55 \text{ }^\circ\text{C}$, $V_i = 230 \text{ VAC}$ unless otherwise noted.

PARAMETER	DESCRIPTION / CONDITION	MIN	NOM	MAX	UNIT
$V_{SB \text{ nom}}$	Nominal Output Voltage		12.15		VDC
$V_{SB \text{ set}}$	Output Setpoint Accuracy				$\%V_{SB \text{ nom}}$
$dV_{SB \text{ tot}}$	Total Regulation				$\%V_{SB \text{ nom}}$
$P_{SB \text{ nom}}$	Nominal output power		42		W
$P_{SB \text{ peak}}$	Peak Output Power ⁵		48		W
$I_{SB \text{ nom}}$	Output Current			3.5	ADC
$I_{SB \text{ peak}}$	Peak Output Current ⁵			4	ADC
$V_{SB \text{ pp}}$	Output Ripple Voltage ⁴			120	mVpp
$dV_{SB \text{ load}}$	Load Regulation				mV
$dV_{SB \text{ line}}$	Line Regulation				mV
$dV_{SB \text{ temp}}$	Thermal Drift				$\% / ^\circ\text{C}$
$dI_{SB \text{ share}}$	Current Sharing				ADC
$dV_{SB \text{ dyn}}$	Load Transient Response				VDC
t_{rec}	Recovery Time				ms
$V_{SB \text{ dyn}}$	Dynamic Load Regulation				V
$t_{V_{SB} \text{ rise}}$	Output Voltage Rise Time				ms
$t_{V_{SB} \text{ ovr sh}}$	Output Turn-on Overshoot				V
$C_{V_{SB} \text{ load}}$	Capacitive Loading				μF

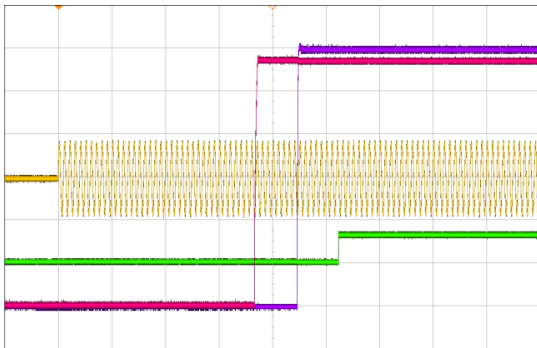

Figure 5. Turn-On AC Line 230 VAC, full load (200 ms/div)
 CH1: V_{in} (400 V/div) CH2: PWOK_H (5 V/div)
 CH3: V_i (2 V/div) CH4: V_{SB} (2 V/div)

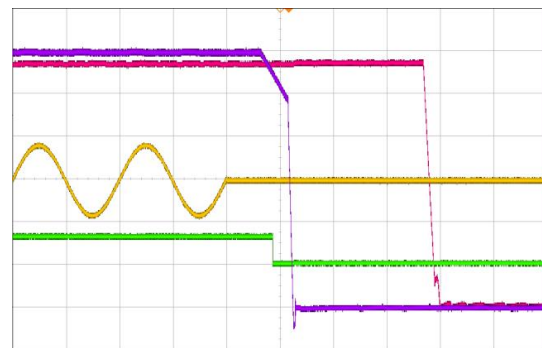

Figure 6 - Turn-Off AC Line 230 VAC, full load (10 ms/div)
 CH1: V_{in} (400 V/div) CH2: PWOK_H (5 V/div)
 CH3: V_i (2 V/div) CH4: V_{SB} (2 V/div)

⁵ In single power supply configuration.

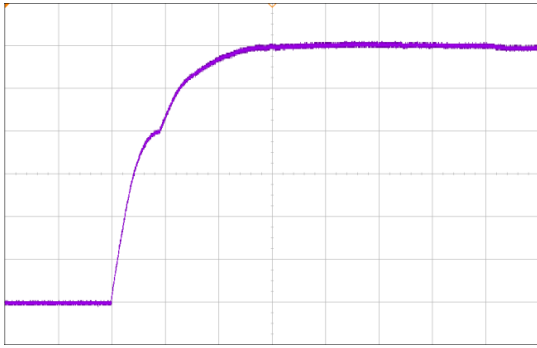

Figure 7. Turn-On AC Line 230 VAC, full load (2 ms/div)
CH3: V_1 (2 V/div)

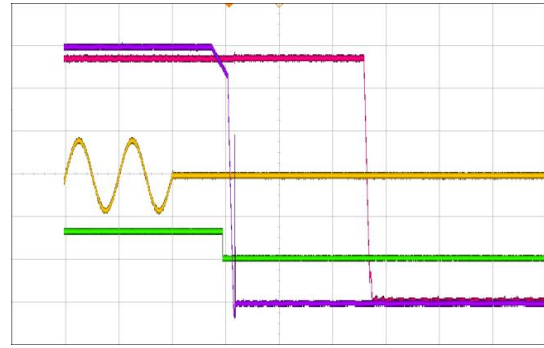

Figure 8. Turn-Off AC Line 230 VAC, half load (20 ms/div)
CH1: V_{in} (400 V/div) CH2: PWOK_H (5 V/div)
CH3: V_1 (2 V/div) CH4: V_{SB} (2 V/div)

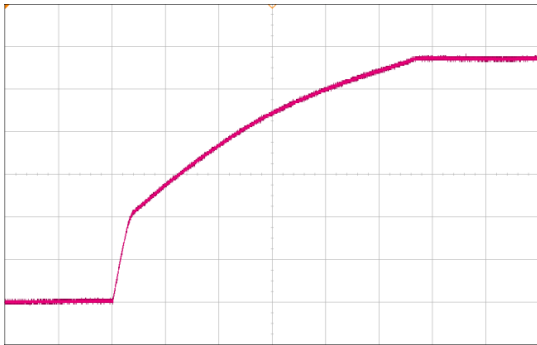

Figure 9. Turn-On AC Line 230 VAC, full load (2 ms/div)
CH4: V_{SB} (2 V/div)

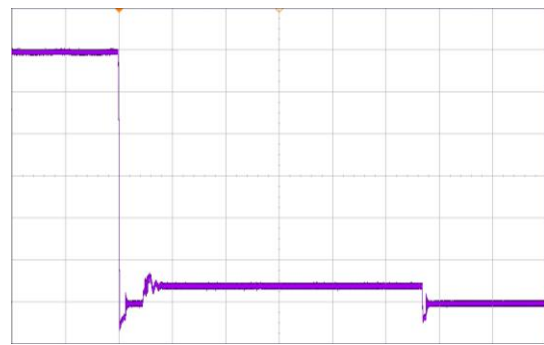

Figure 10. Short circuit on V_1 (10 ms/Div)
CH3: V_1 (2 V/div)

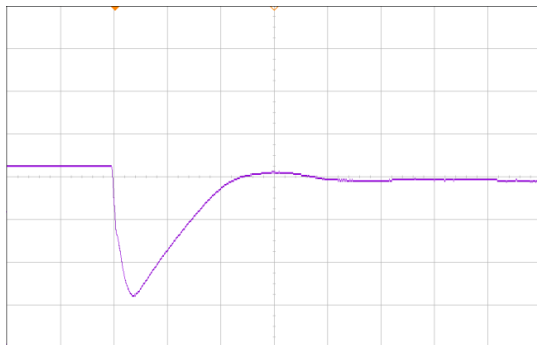

Figure 11. Load transient V_1 , 133A to 67A (1 ms/div)
CH3: V_1 (2 V/div) CH4: V_{SB} (2 V/div)

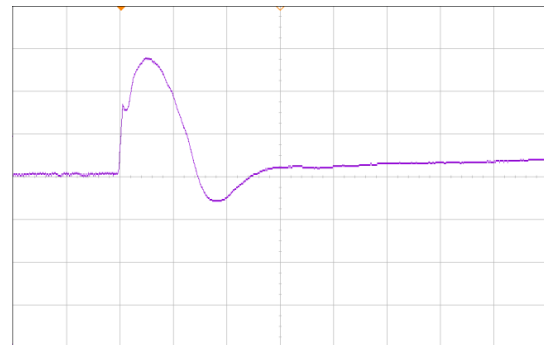

Figure 12. Load transient V_1 , 67A to 133 A (1 ms/div)
CH3: V_1 (200 mV/div)

5.3 OUTPUT GROUND / CHASSIS CONNECTION

The output return path serves as power and signal ground. All output voltages and signals are referenced to these pins. To prevent a shift in signal and voltage levels due to ground wiring voltage drop a low impedance ground plane should be used as shown in [Figure 13](#). Alternatively, separated ground signals can be used as shown in [Figure 14](#). In this case the two ground planes should be connected together at the power supplies ground pins.



Asia-Pacific	Europe, Middle East	North America
+86 755 298 85888	+353 61 225 977	+1 408 785 5200

NOTE:

Within the power supply the output GND pins are connected to the Chassis, which in turn is connected to the Protective Earth terminal on the AC inlet. Therefore, it is not possible to set the potential of the output return (GND) to any other than Protective Earth potential.

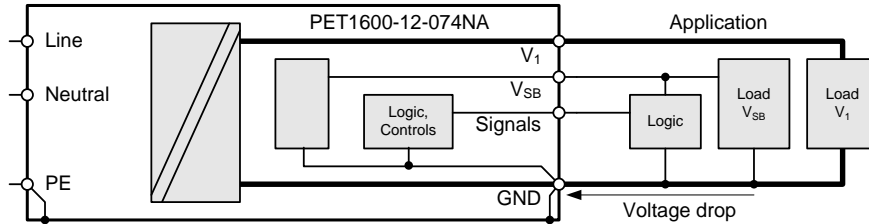

Figure 13. Common low impedance ground plane

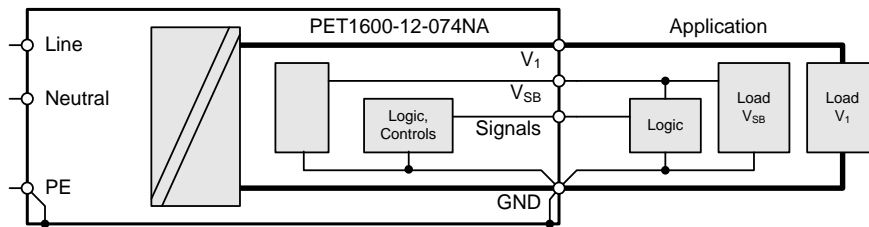

Figure 14. Separated power and signal ground

6. PROTECTION

PARAMETER	DESCRIPTION / CONDITION	MIN	NOM	MAX	UNIT	
F	Input fuse (L)	Not use accessible, time-lag (T)			16	A
$V_{1 OV}$	OV Threshold V_1	13.3	13.9	14.5	VDC	
$t_{V1 OV}$	OV Trip Time V_1	Over Voltage V_1 Protection, Latch-off Type			1	ms
$V_{VSB OV}$	OV Threshold V_{SB}	13.3	13.9	14.5	VDC	
$t_{VSB OV}$	OV Trip Time V_{SB}	Over Voltage V_1 Protection, Automatic retry each 1s			1	ms
$I_{V1 OC Slow}$	OC Limit V_1	Over Current Limitation, Latch-off, $V_{1 min HL}$ to $V_{1 max HL}$			135	ADC
		Over Current Limitation, Latch-off, $V_{1 min LL}$ to $V_{1 max LL}$			85	ADC
$t_{V1 OC Slow}$	OC Trip time V_1	Over Current Limitation, Latch-off time			20	s
$I_{V1 OC Fast}$	Fast OC Limit V_1	Fast Over Current Limit., Latch-off, $V_{1 min HL}$ to $V_{1 max HL}$			175	ADC
		Fast Over Current Limit., Latch-off, $V_{1 min LL}$ to $V_{1 max LL}$			110	ADC
$t_{V1 OC Fast}$	Fast OC Trip time V_1	Fast Over Current Limitation, Latch-off time			50	ms
$I_{V1 SC}$	Max Short Circuit Current V_1	$V_1 < 3 V$			180	A
$t_{V1 SC}$	Short Circuit Regulation Time	$V_1 < 3 V$, time until I_{V1} is limited to $< I_{V1 SC}$			2	ms
$I_{VSB OC}$	OC Limit V_{SB}	4.1	4.5	4.9	A	
$t_{VSB OC}$	OC Trip time V_{SB}	Over Current Limit., time until I_{VSB} is limited to $I_{VSB OC}$			10	ms
T_{SD}	Over Temperature On Heat Sinks	See chapter 10.2				°C

6.1 OVERVOLTAGE PROTECTION

The PET1600-12-074NA front-end provides a fixed threshold overvoltage (OV) protection implemented with a HW comparator for both the main and the standby output. Once an OV condition has been triggered on the main output, the supply will shut down and latch the fault condition. The latch can be unlocked by disconnecting the supply from the AC mains or by toggling the PSON_L input. The standby output will continuously try to restart with a 1 s interval after OV condition has occurred.

6.2 UNDERVOLTAGE DETECTION

Both main and standby outputs are monitored. LED and PWOK_H pin signal if the output voltage exceeds $\pm 5\%$ of its nominal voltage.

The main output will latch off if the main output voltage V_1 falls below 10 V (typically in an overload condition) for more than 55 ms. The latch can be unlocked by disconnecting the supply from the AC mains or by toggling the PSON_L input.

If the standby output leaves its regulation bandwidth for more than 2 ms then the main output is disabled to protect the system.

6.3 CURRENT LIMITATION

MAIN OUTPUT

The main output exhibits a substantially rectangular output characteristic controlled by a software feedback loop. If output current exceeds $I_{V1 OC Fast}$ it will reduce output voltage in order to keep output current at $I_{V1 OC Fast}$. If the output voltage drops below ~ 10.0 VDC for more than 55 ms, the output will latch off (standby remains on), see also [Undervoltage Detection](#).

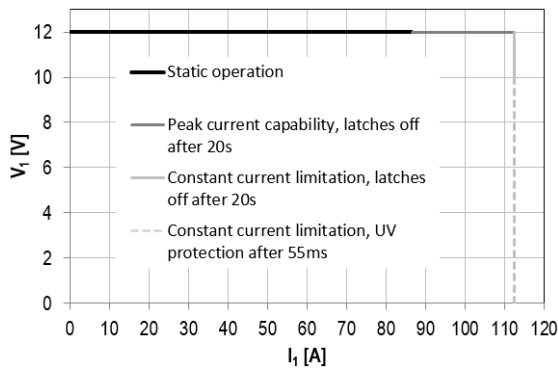

Figure 15. Current Limitation on V_1 at $V_i = 90 \dots 140$ VAC

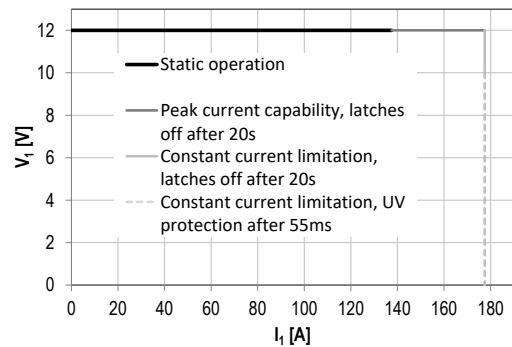

Figure 16. Current Limitation on V_1 at $V_i = 180 \dots 264$ VAC

A second SW controlled current limit will latch off the main output if the power supply is operated for long duration in its peak current capability region. This protection trips as soon as the output current exceeds $I_{V1 OC Slow}$ for duration of more than 20 s. The third current limitation implemented as a fast hardware circuit will immediately switch off the main output if the output current increases beyond the peak current trip point, occurring mainly if a short circuit is applied to the output voltage. The supply will re-start 4 ms later with a soft start, if the short circuit persists ($V_1 < 10.0$ V for >55 ms) the output will latch off; otherwise it continues to operate.

The latch can be unlocked by disconnecting the supply from the AC mains or by toggling the PSON_L input.

The main output current limitation thresholds for $I_{V1 OC Slow}$ and $I_{V1 OC Fast}$ depend on the actual input voltage range applied to the power supply. In addition, the threshold for $I_{V1 OC Slow}$ is reduced when ambient temperature exceeds 55°C , see Error! Reference source not found..

STANDBY OUTPUT

The standby output exhibits a substantially rectangular output characteristic down to 0 V (no hiccup mode / latch off). The current limitation of the standby output is independent of the AC input voltage.

Running in current limitation causes the output voltage to fall, this will trigger under voltage protection and disables the main output, see also [Undervoltage Detection](#).

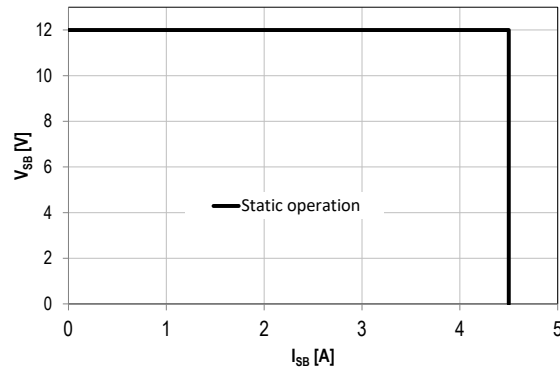

Figure 17. Current Limitation on V_{SB}

7. MONITORING

The power supply operating parameters can be accessed through I²C interface. For more details refer to chapter *I²C / POWER MANAGEMENT BUS COMMUNICATION* and document URP.00234 (PET2000-12-074NA Power Management Bus Communication Manual).

PARAMETER	DESCRIPTION / CONDITION	MIN	NOM	MAX	UNIT
$V_{i\ mon}$	Input RMS Voltage $V_{i\ min\ LL} \leq V_i \leq V_{i\ max\ HL}$	-2		+2	VAC
$I_{i\ mon}$	Input RMS Current $I_i > 6.7\ Arms$	-3		+3	%
	$I_i \leq 6.7\ Arms$	-0.2		+0.2	A_{rms}
$P_{i\ mon}$	True Input Power $P_i > 250\ W$	-4		+4	%
	$P_i < 250\ W$	-10		+10	W
$V_{I\ mon}$	V_I Voltage	-0.1		+0.1	VDC
$I_{I\ mon}$	V_I Current $I_I > 25\ A$	-1		+1	%
	$I_I \leq 25\ A$	-0.25		+0.25	ADC
$P_{I\ nom}$	V_I Output Power $P_I > 250\ W$	-2		+2	%
	$P_I < 250\ W$	-5		+5	W
$V_{SB\ mon}$	V_{SB} Voltage	-0.1		+0.1	VDC
$I_{SB\ mon}$	V_{SB} Current	-0.1		+0.1	ADC
$T_{A\ mon}$	Inlet Temperature $T_{A\ min} \leq T_A \leq T_{A\ max}$	-2		+2	°C

8. SIGNALING AND CONTROL

8.1 ELECTRICAL CHARACTERISTICS

PARAMETER	DESCRIPTION / CONDITION		MIN	NOM	MAX	UNIT
PSON_H / HOTSTANDBYEN_L						
V_{IL}	Input Low Level Voltage	PSON_L: Main output enabled HOTSTANDBYEN_H: Hot Standby mode not allowed	-0.2		0.8	V
V_{IH}	Input High Level Voltage	PSON_L: Main output disabled HOTSTANDBYEN_H: Hot Standby mode allowed	2		3.5	V
$I_{L,H}$	Maximum Input Sink or Source Current	$V_I = -0.2\text{ V to }+3.5\text{ V}$	-1		1	mA
$R_{pull\ up}$	Internal Pull up Resistor to internal 3.3V			10		kΩ
R_{LOW}	Maximum external Pull down Resistance to GND to obtain Low Level				1	kΩ
R_{HIGH}	Minimum external Pull down Resistance to GND to obtain High Level		50			kΩ
PWOK_H						
V_{OL}	Output Low Level Voltage	$V_I < V_{i\ min\ LL}, V_{s\ sink} < 4\text{ mA}$	0		0.4	V
V_{OH}	Output High Level Voltage	$V_I > V_{i\ min\ LL}, I_{source} < 0.5\text{ mA}$	2.4		3.5	V
$R_{pull\ up}$	Internal Pull up Resistor to internal 3.3V			1		kΩ
I_{OL}	Maximum Sink Current	$V_O < 0.4\text{ V}$			4	mA

8.2 SENSE INPUTS

The main output has sense lines implemented to compensate for voltage drop on load wires in both positive and negative path. The maximum allowed voltage drop is 200 mV on the positive rail and 50 mV on the GND rail. With open sense inputs the main output voltage will rise by 270 mV. Therefore if not used, these inputs should be connected to the power output and GND at the power supply connector. The sense inputs are protected against short circuit. In this case the power supply will shut down.

8.3 CURRENT SHARE

The PET front-ends have an active current share scheme implemented for V1. All ISHARE pins need to be interconnected in order to activate the current sharing functionality. If a supply has an internal fault or is not turned on, it will disconnect its ISHARE pin from the share bus. This will prevent dragging the output down (or up) in such cases. The current share function uses an analog bus to transmit and receive current share information. The controller implements a Master/Slave current share function. The power supply providing the largest current among the group is automatically the Master. The other supplies will operate as Slaves and increase their output current to a value close to the Master by slightly increasing their output voltage. The voltage increase is limited to +250 mV. The standby output uses a passive current share method (droop output voltage characteristic).

8.4 PSON_L INPUT

The PSON_L is an internally pulled-up (3.3 V) input signal to enable/disable the main output V1 of the front-end. With low level input the main output is enabled. Toggling this active-low pin is also used to clear any latched fault condition. The PSON_L can either be controlled by an open collector device or by a voltage source.



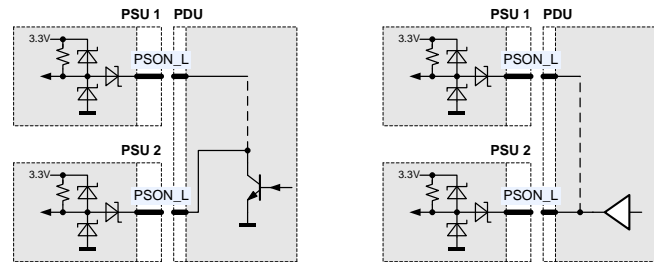

Figure 18. PS_ON_H connection

8.5 PWOK_H OUTPUT

The PWOK_H is an open drain output with an internal pull-up to 3.3 V indicating whether both VSB and V1 outputs are within regulation. This pin is active-low.

An external pull down resistor ensures low level when there is no power supply seated. When combining PWOK_H outputs of several power supplies, circuits as shown in [Figure 19](#) should be used.

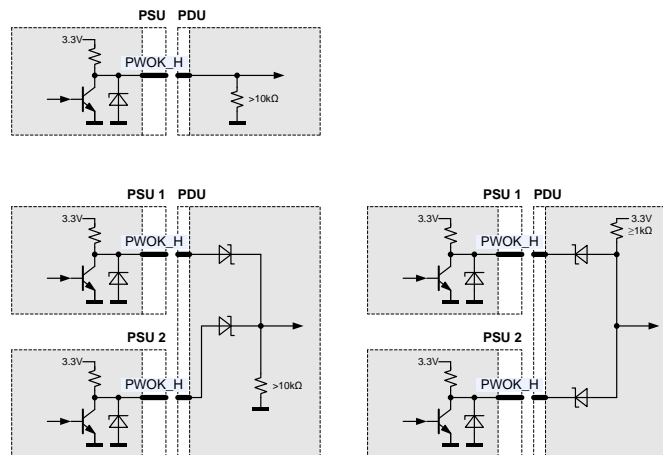

Figure 19. PWOK_H connection

8.6 HOT-STANDBY IN-/OUTPUT

The hot-standby operation is an operating mode allowing to further increase efficiency at light load conditions in a redundant power supply system. Under specific conditions one of the power supplies is allowed to disable its DC/DC stage. This will save the power losses associated with this power supply and at the same time the other power supply will operate in a load range having a better efficiency. In order to enable the hot standby operation, the HOTSTANDBYEN_H and the ISHARE pins need to be interconnected between the power supplies. A power supply will only be allowed to enter the hot-standby mode, when the HOTSTANDBYEN_H pin is high, the load current is low (see [Figure 20](#)) and the supply was allowed to enter the hot-standby mode by the system controller via the appropriate I²C command (by default disabled). The system controller needs to ensure that only one of the power supplies is allowed to enter the hot-standby mode.

If a power supply is in a fault condition, it will pull low its active-high HOTSTANDBYEN_H pin which indicates to the other power supply that it is not allowed to enter the hot-standby mode or that it needs to return to normal operation should it already have been in the hot-standby mode.

NOTE:

The system controller needs to ensure that only one of the power supplies is allowed to enter the hot-standby mode.

[Figure 21](#) shows the achievable power loss savings when using the hot-standby mode operation. A total power loss reduction of approx. 10W is achievable.

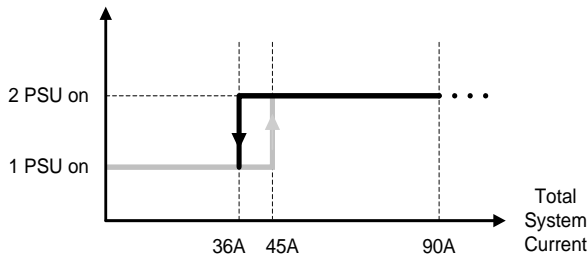

Figure 20. Hot-standby enable/disable current thresholds

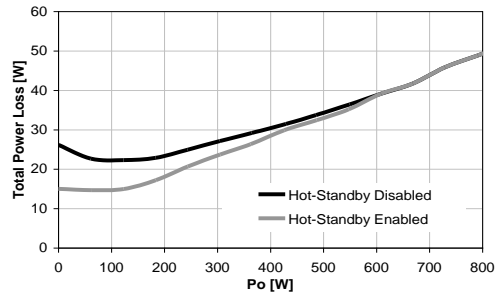

Figure 21. PSU power losses with/without hot-standby mode

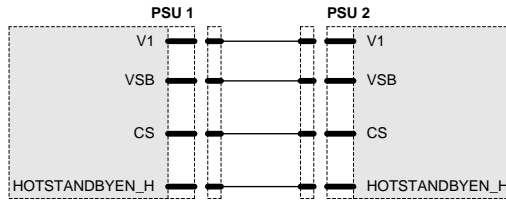

Figure 22. Recommended hot-standby configuration

8.7 PRESENT_L OUTPUT - AVAILABLE ONLY ON VERSION PET1600-12-074NAS311

The PRESENT_L pin is wired through a 100 Ohms resistor to internal GND within the power supply. This pin indicates that there is a power supply present in this system slot. An external pull-up resistor has to be added within the application. Current into the PRESENT_L pin should not exceed 5 mA to guarantee a low level voltage if power supply is seated.

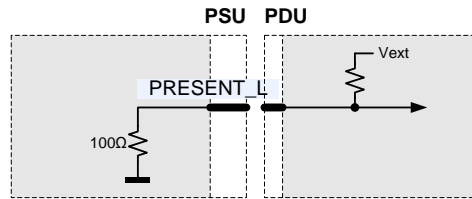

Figure 23. PRESENT_L connection

8.8 SIGNAL TIMING

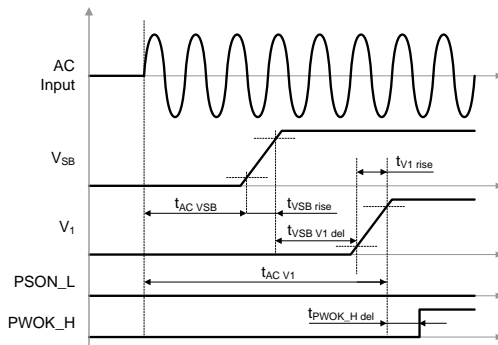

Figure 24. AC turn-on timing

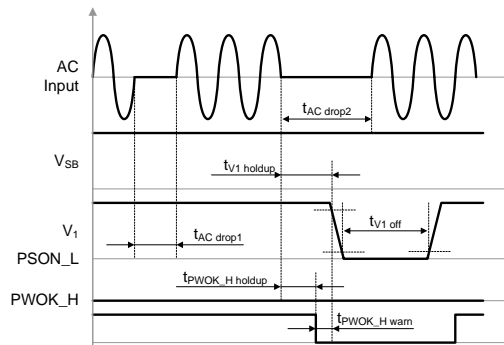

Figure 25. AC short dips

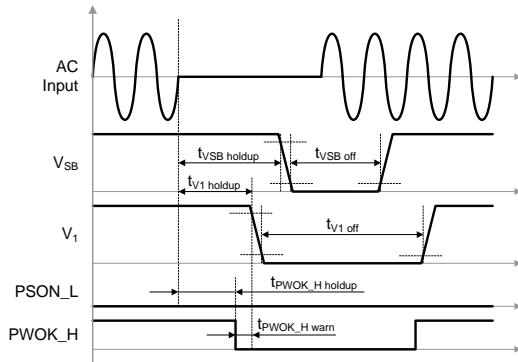

Figure 26. AC long dips

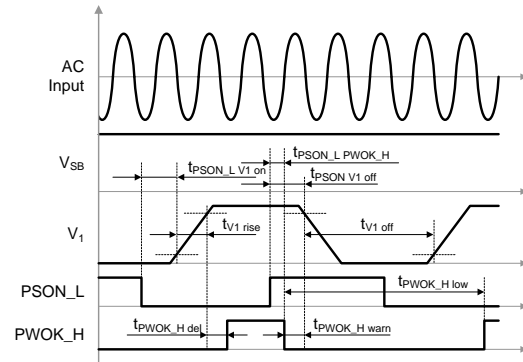

Figure 27. PSON_L turn-on/off timing

PARAMETER	DESCRIPTION / CONDITION	MIN	NOM	MAX	UNIT
$t_{AC\ VSB}$	AC Line to 90% V_{SB}			3.5 ⁶	s
$t_{AC\ V1}$	AC Line to 90% V_1			4 ⁶	s
$t_{VSB\ V1\ del}$	V_{SB} to V_1 delay	50	250	1000	ms
$t_{V1\ rise}$	V_1 rise time				See chapter Output
$t_{VSB\ rise}$	V_{SB} rise time				See chapter Output
$t_{AC\ drop1}$	AC drop without V_1 leaving regulation			10	ms
$t_{AC\ drop2}$	AC drop without V_{SB} leaving regulation			70	ms
$t_{V1\ holdup}$	Loss of AC to V_1 leaving regulation				See chapter Input
$t_{VSB\ holdup}$	Loss of AC to V_1 leaving regulation				See chapter Input
$t_{PWOK_H\ del}$	Outputs in regulation to PWOK_H asserted	100	250	200	ms
$t_{PWOK_H\ warn}$	Warning time from de-assertion of PWOK_H to V_1 leaving regulation	0.15			ms
$t_{PWOK_H\ holdup}$	Loss of AC to PWOK_H de-asserted				$V_{1\ nom\ HL}, I_{1\ nom}, I_{SB\ nom}$ ms
$t_{PWOK_H\ low}$	Time PWOK_H is kept low after being de-asserted	100			ms
$t_{PSON_L\ V1\ on}$	Delay PSON_L active to V_1 in regulation	5	10	20	ms
$t_{PSON_L\ V1\ off}$	Delay PSON_L de-asserted to V_1 disabled	2	3	4	ms
$t_{PSON_L\ PWOK_H}$	Delay PSON_L de-asserted to PWOK_H de-asserted		1	2	ms
$t_{V1\ off}$	Time V_1 is kept off after leaving regulation		1		s
$t_{VSB\ off}$	Time V_{SB} is kept off after leaving regulation		1		s

⁶ At repeated ON-OFF cycles the start-up time can be increased by 1s

8.9 LED INDICATOR

The front-end has one front LED showing the status of the supply. The LED is bi-colored: green and amber, and indicates AC and DC power presence and warning or fault conditions. *Table 1* lists the different LED status.

OPERATING CONDITION *	LED SIGNALING
No AC or AC Line in UV condition, V_{SB} not present from paralleled power supplies	Off
PSO _N _L High Hot-Standby Mode	Blinking Green 1Hz
No AC or AC Line in UV condition, V_{SB} present from paralleled power supplies V_I or V_{SB} out of regulation Over temperature shutdown Output over voltage shutdown (V_I or V_{SB}) Output over current shutdown (V_I or V_{SB}) Fan error (>15%)	Solid Amber
Over temperature warning Minor fan regulation error (>5%, <15%)	Blinking Amber 1Hz
Firmware boot loading in process	Blinking Green 2Hz
Outputs V_I and V_{SB} in regulation	Solid Green

* The order of the criteria in the table corresponds to the testing precedence in the controller.

Table 1. LED Status

9. I²C / POWER MANAGEMENT BUS COMMUNICATION

The PET front-end is a communication Slave device only; it never initiates messages on the I²C/SMBus by itself. The communication bus voltage and timing is defined in *Table 2* and further characterized through:

- The SDA/SCL IOs use 3.3 V logic levels
- External pull-up resistors on SDA/SCL required for correct signal edges
- Full SMBus clock speed of 100 kbps
- Clock stretching limited to 1 ms
- SCL low time-out of >25 with recovery within 10 ms
- Recognizes any time Start/Stop bus conditions

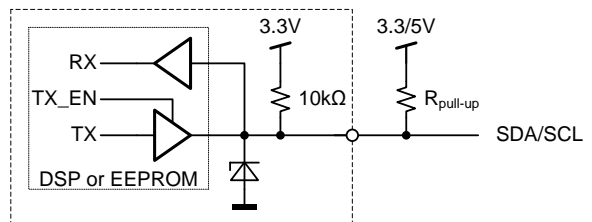

Figure 28. Physical layer of communication interface

Communication to the DSP or the EEPROM will be possible as long as the input AC voltage is provided. If no AC is present, communication to the unit is possible as long as it is connected to a life V_{SB} output (provided e.g. by a redundant unit). If only V_I is provided, communication is not possible.

PARAMETER	DESCRIPTION	CONDITION	MIN	MAX	UNIT
SCL / SDA					
V_{IL}	Input low voltage		-0.5	1.0	V
V_{IH}	Input high voltage		2.3	3.5	V
V_{Hys}	Input hysteresis		0.15		V
V_{OL}	Output low voltage	3 mA sink current	0	0.4	V
t_r	Rise time for SDA and SCL		$20+0.1C_b^1$	300	ns
t_{of}	Output fall time $V_{IHmin} \rightarrow V_{ILmax}$	$10 \text{ pF} < C_b^1 < 400 \text{ pF}$	$20+0.1C_b^1$	250	ns
I_i	Input current SCL/SDA	$0.1 \text{ VDD} < V_i < 0.9 \text{ VDD}$	-10	10	μA
C_i	Internal Capacitance for each SCL/SDA			50	pF
f_{SCL}	SCL clock frequency		0	100	kHz
$R_{pull-up}$	External pull-up resistor	$f_{SCL} \leq 100 \text{ kHz}$		$1000 \text{ ns} / C_b^1$	Ω
t_{HDSTA}	Hold time (repeated) START	$f_{SCL} \leq 100 \text{ kHz}$	4.0		μs
t_{LOW}	Low period of the SCL clock	$f_{SCL} \leq 100 \text{ kHz}$	4.7		μs
t_{HIGH}	High period of the SCL clock	$f_{SCL} \leq 100 \text{ kHz}$	4.0		μs
t_{SUSTA}	Setup time for a repeated START	$f_{SCL} \leq 100 \text{ kHz}$	4.7		μs
t_{HDDAT}	Data hold time	$f_{SCL} \leq 100 \text{ kHz}$	0	3.45	μs
t_{SUDAT}	Data setup time	$f_{SCL} \leq 100 \text{ kHz}$	250		ns
t_{SUSTO}	Setup time for STOP condition	$f_{SCL} \leq 100 \text{ kHz}$	4.0		μs
t_{BUF}	Bus free time between STOP and START	$f_{SCL} \leq 100 \text{ kHz}$	5		ms

¹ C_b = Capacitance of bus line in pF, typically in the range of 10...400 pF

Table 2. I^2C / SMBus Specification

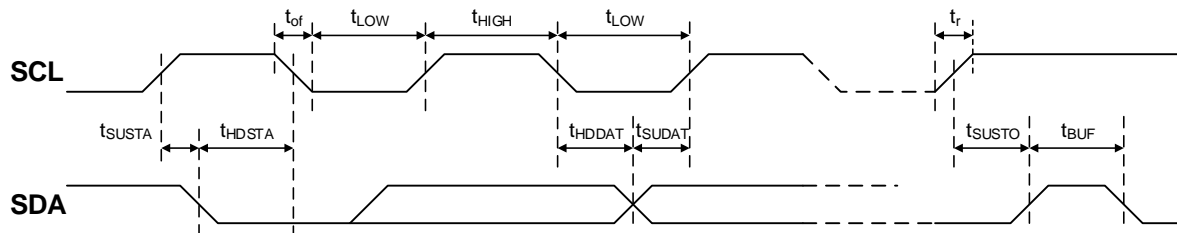

Figure 29. I^2C / SMBus Timing

ADDRESS SELECTION

The address for I^2C communication can be configured by pulling address input pins A1 and A0 either to GND (logic low) or leave them open (logic high). An internal pull up resistor will cause the A1 / A0 pin to be in high level if left open. A fixed addressing offset exists between the Controller and the EEPROM.

A2 ²⁾	A1	A0	I2C Address ¹⁾	
			Controller	EEPROM
0	0	0	0xB0	0xA0
0	0	1	0xB2	0xA2
0	1	0	0xB4	0xA4
0	1	1	0xB6	0xA6
1	0	0	0xB8	0xA8
1	0	1	0xBA	0xAA
1	1	0	0xBC	0xAC
1	1	1	0xBE	0xAE

¹⁾ The LSB of the address byte is the R/W bit.

²⁾ A2 is available only on model PET1600-12-074NAS311. If it is not available, A2 = 0.

Table 3. Address and protocol encoding

9.1 SMBALERT_L OUTPUT

The SMBALERT_L signal indicates that the power supply is experiencing a problem that the system agent should investigate. This is a logical OR of the Shutdown and Warning events. It is asserted (pulled Low) at Shutdown or Warning events such as reaching temperature warning/shutdown threshold of critical component, general failure, over-current, over-voltage, under-voltage or low-speed of a failed fan. This signal may also indicate the power supply is operating in an environment exceeding the specified limits.

The SMBAlert signal is asserted simultaneously with the LED turning to solid amber or blinking amber.

PARAMETER	DESCRIPTION / CONDITION	MIN	NOM	MAX	UNIT
SMB_ALERT_L					
V_{ext}	Maximum External Pull up Voltage			12	V
I_{OH}	Maximum High Level Leakage Current	No Failure or Warning condition, $V_O = 12\text{ V}$		10	μA
V_{OL}	Output Low Level Voltage	Failure or Warning condition, $I_{sink} < 4\text{ mA}$		0.4	V
$R_{pull\ up}$	Internal Pull up Resistor to internal 3.3 V		None		
I_{OL}	Maximum Sink Current	$V_O < 0.4\text{ V}$		4	mA

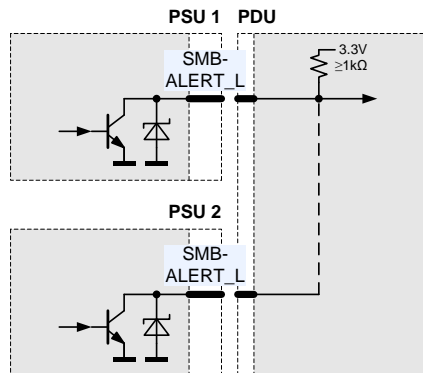

Figure 30. SMBALERT_L connection

9.2 CONTROLLER AND EEPROM ACCESS

The controller and the EEPROM in the power supply share the same I²C bus physical layer (see *Figure 31*) and can be accessed under different addresses, see ADDRESS SELECTION.

The SDA/SCL lines are connected directly to the controller and EEPROM which are supplied by internal 3.3 V.

The EEPROM provides 256 bytes of user memory. None of the bytes are used for the operation of the power supply.

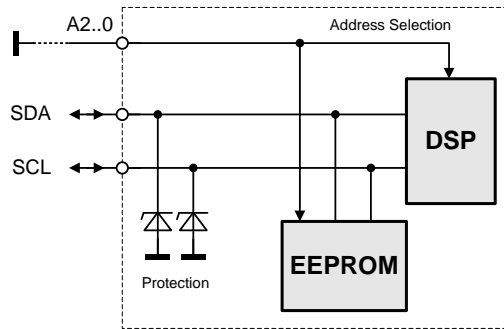

Figure 31. I²C Bus to DSP and EEPROM

9.3 EEPROM PROTOCOL

The EEPROM follows the industry communication protocols used for this type of device. Even though page write / read commands are defined, it is recommended to use the single byte write / read commands.

WRITE

The write command follows the SMBus 1.1 Write Byte protocol. After the device address with the write bit cleared a first byte with the data address to write to is sent followed by the data byte and the STOP condition. A new START condition on the bus should only occur after 5ms of the last STOP condition to allow the EEPROM to write the data into its memory.



READ

The read command follows the SMBus 1.1 Read Byte protocol. After the device address with the write bit cleared the data address byte is sent followed by a repeated start, the device address and the read bit set. The EEPROM will respond with the data byte at the specified location.

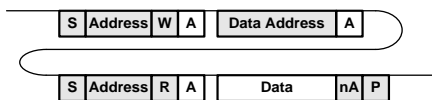

9.4 POWER MANAGEMENT BUS PROTOCOL

The Power Management Bus is an open standard protocol that defines means of communicating with power conversion and other devices. For more information, please see the System Management Interface Forum web site at www.powerSIG.org.

Power Management Bus command codes are not register addresses. They describe a specific command to be executed. The PET1600-12-074NA supply supports the following basic command structures:

- Clock stretching limited to 1 ms
- SCL low time-out of >25 ms with recovery within 10 ms
- Recognized any time Start/Stop bus conditions

WRITE

The write protocol is the SMBus 1.1 Write Byte/Word protocol. Note that the write protocol may end after the command byte or after the first data byte (Byte command) or then after sending 2 data bytes (Word command).

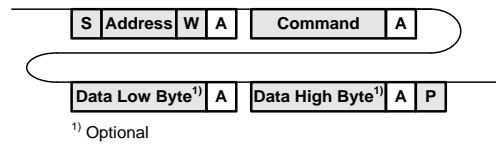

In addition, Block write commands are supported with a total maximum length of 255 bytes. See PET2000-12-074NA Power Management Bus Communication Manual URP.00234 for further information.

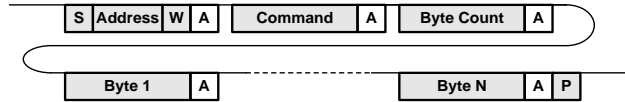

READ

The read protocol is the SMBus 1.1 Read Byte/Word protocol. Note that the read protocol may request a single byte or word.

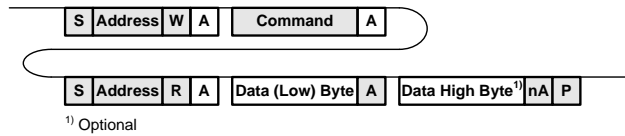

In addition, Block read commands are supported with a total maximum length of 255 bytes. See PET2000-12-074NA Power Management Bus Communication Manual URP.00234 for further information.

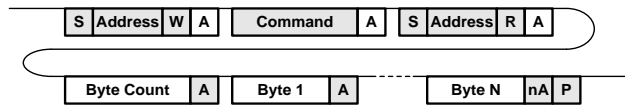

9.5 GRAPHICAL USER INTERFACE

Bel Power Solutions provides with its “I²C Utility” a Windows® XP/Vista/Win7 compatible graphical user interface allowing the programming and monitoring of the PET1600-12-074NA Front-End.

The utility can be downloaded from: belfuse.com/power-solutions and supports both the PSMI and Power Management Bus protocols.

The GUI allows automatic discovery of the units connected to the communication bus and will show them in the navigation tree. In the monitoring view the power supply can be controlled and monitored.

If the GUI is used in conjunction with the YTM.00045 Evaluation Board it is also possible to control the PSON_L pin(s) of the power supply.

NOTE:

The user of the GUI needs to ensure that only one of the power supplies have the hot-standby mode enabled.

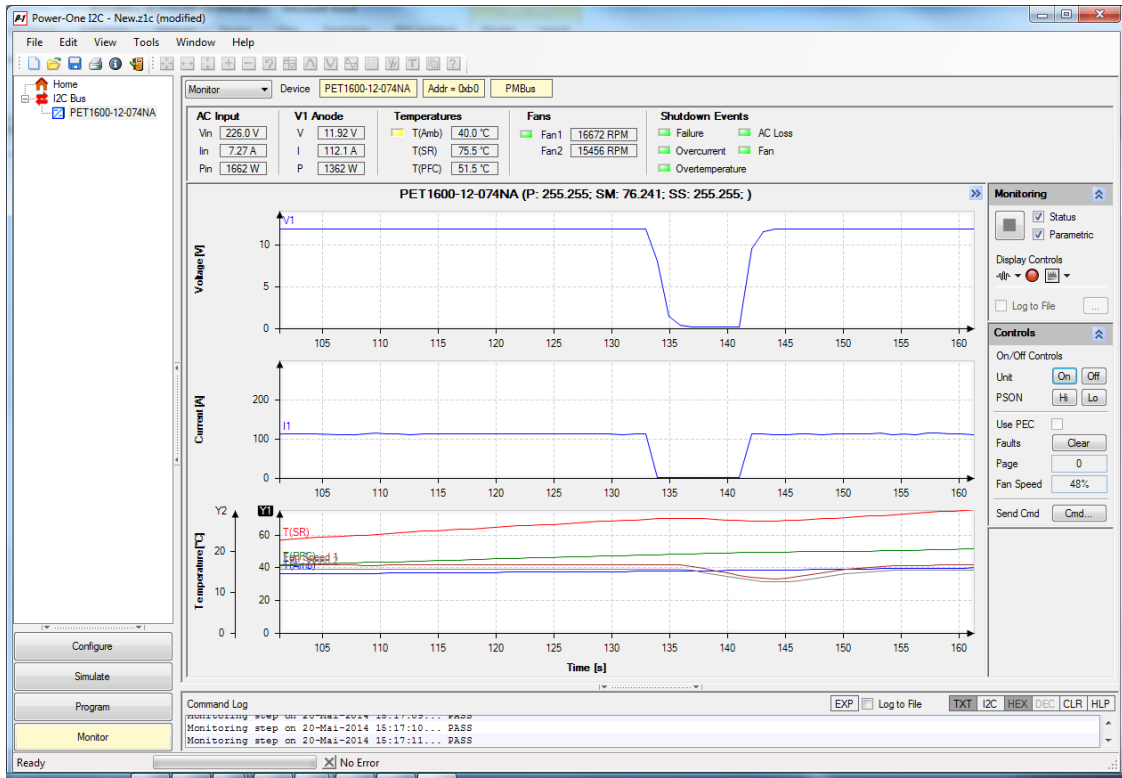

Figure 32. Monitoring dialog of the PC Utility

10. TEMPERATURE AND FAN CONTROL

10.1 FAN CONTROL

To achieve best cooling results sufficient airflow through the supply must be ensured. Do not block or obstruct the air-flow at the rear of the supply by placing large objects directly at the output connector. The PET1600-12-074NA is provided with a rear to front airflow, which means the air enters through the DC-output of the supply and leaves at the AC-inlet. The PET1600-12-074NA supply has been designed for horizontal operation.



Figure 33. Airflow direction

The fan inside the supply is controlled by a microprocessor. The rpm of the fan is adjusted to ensure optimal supply cooling and is a function of output power. Three different curves are selected based on input voltage and inlet temperature. With standby output loaded the fan speed minimum is limited to ensure enough cooling of circuits providing standby power. Figure 34 illustrates the programmed fan curves.

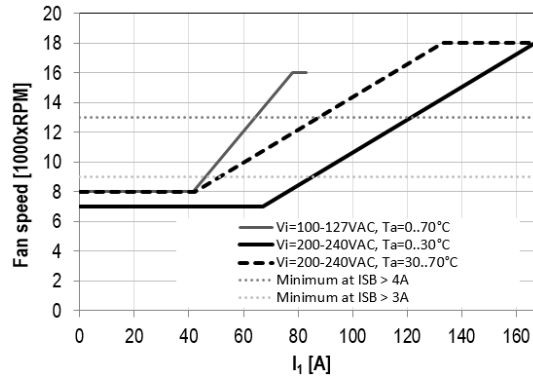

Figure 34. Fan speed vs. main output load

10.2 TEMPERATURE MONITOR AND OVER TEMPERATURE PROTECTION

The PET1600-12-074NA provides access via I²C to the measured temperatures of in total 6 sensors within the power supply, see [Table 4](#). The microprocessor is monitoring these temperatures and if warning threshold of one of these sensors is reached it will set fan to maximum speed. If temperatures continue to rise above shutdown threshold the main output V_I (or V_{SB} if auxiliary converter is affected) will be disabled. At the same time the warning or fault condition is signaled accordingly through LED, PWOK_H and SMBALERT_L.

TEMPERATURE SENSOR	DESCRIPTION / CONDITION	POWER MANAGEMENT BUS REGISTER	WARNING THRESHOLD	SHUTDOWN THRESHOLD
Inlet air temperature	Sensor located on control board close to DC end of power supply	8Dh	73°C	78°C
Synchronous rectifier	Sensor located on secondary side of DC/DC stage	8Eh	95°C	100°C
Primary heat sink	Sensor located on primary heat sink	8Fh	87°C	92°C
Output ORing element	Sensor located close to output	D2h	100°C	105°C
Auxiliary converter	Sensor located on secondary side on auxiliary rectifier	D3h	80°C	85°C
Bridge rectifier	Sensor located on heat sink for AC rectifier	D4h	86°C	91°C

Table 4 – Temperature sensor location and thresholds

11. ELECTROMAGNETIC COMPATIBILITY

11.1 IMMUNITY

PARAMETER	DESCRIPTION / CONDITION	CRITERION
ESD Contact Discharge	IEC / EN 61000-4-2, ±8 kV, 25+25 discharges per test point (metallic case, LED, connector body)	A
ESD Air Discharge	IEC / EN 61000-4-2, ±15 kV, 25+25 discharges per test point (non-metallic user accessible surfaces)	A
Radiated Electromagnetics Filled	IEC / EN 61000-4-3, 10 V/m, 1 kHz/80% Amplitude Modulation, 1µs Pulse Modulation, 10 kHz ... 2 GHz	A
Burst	IEC / EN 61000-4-4, Level 3 AC port ±2 kV, 1 minute	A
Surge	IEC / EN 61000-4-5, Level 3 Line to Earth: ±2 kV Line to Line: ±1 kV	A
RF Conducted Immunity	IEC / EN 61000-4-6, Level 3, 10 Vrms, CW, 0.1 ... 80 MHz	A
Voltage Dips and Interruptions	IEC / EN 61000-4-11 1. V_I 230VAC, 70% load, Phase 0°, Dip 100% , duration 10.6 ms 2. V_I 230VAC, 70% load, Phase 0°, Dip 100% , duration 70 ms 3. V_I 230VAC, 70% load, Phase 0°, Dip 100% , duration 100 ms	V_I : A, V_{SB} : A V_I : B, V_{SB} : A V_I : B, V_{SB} : B



a bel group

Asia-Pacific Europe, Middle East North America
+86 755 298 85888 +353 61 225 977 +1 408 785 5200

11.2 EMISSION

PARAMETER	DESCRIPTION / CONDITION	CRITERION
Conducted Emission	EN 55022 / CISPR 22: 0.15 ... 30 MHz, QP and AVG, single power supply	Class A 6 dB margin
	EN 55022 / CISPR 22: 0.15 ... 30 MHz, QP and AVG, 2 power supplies in a system	Class A
Radiated Emission	EN 55022 / CISPR 22: 30 MHz ... 1 GHz, QP, single power supply	Class A 6 dB margin
	EN 55022 / CISPR 22: 30 MHz ... 1 GHz, QP, 2 power supplies in a system	Class A
Harmonic Emissions	IEC 61000-3-2, $V_i = 115 \text{ VAC} / 60 \text{ Hz} \ \& \ 230 \text{ VAC} / 50 \text{ Hz}$, 100% Load	Class A
AC Flicker	IEC 61000-3-3, $V_i = 230 \text{ VAC} / 50 \text{ Hz}$, 100% Load	Pass
Acoustical Noise	Distance 1 meter, 25°C, 50% Load	65 dBA

12. SAFETY / APPROVALS

Maximum electric strength testing is performed in the factory according to IEC/EN 60950, and UL 60950. Input-to-output electric strength tests should not be repeated in the field. Bel Power Solutions will not honor any warranty claims resulting from electric strength field tests.

PARAMETER	DESCRIPTION / CONDITION	NOTES
Agency Approvals	Approved to latest edition of the following standards: UL/CSA60950-1, IEC60950-1 and EN60950-1, NEMKO NO86275, EAC NO 0230738, BSMI CNS14336-1 and CNS13438	
Isolation Strength	Input (L/N) to chassis (PE)	Basic
	Input (L/N) to output	Reinforced
	Output to chassis	None (Direct connection)
Creepage / Clearance	Primary (L/N) to chassis (PE)	
	Primary to secondary	
Electrical Strength Test	Input to chassis	Min. 2121 VDC
	Input to output (tested by manufacturer only)	4242 VDC

13. ENVIRONMENTAL

PARAMETER	DESCRIPTION / CONDITION	MIN	NOM	MAX	UNIT
T_A Ambient Temperature	Up to 1'000m ASL	0		+55	°C
	Linear derating from 1'000 to 3'048m ASL			+45	°C/
T_{Aext} Extended Temp. Range				TBD	°C
T_S Storage Temperature	Non-operational	-20		+70	°C
Altitude	Operational, above Sea Level	-		3'048	m
	Non-operational, above Sea Level	-		10'600	m
Shock, operational	Half sine, 11ms, 10 shocks per direction, 6 directions			1	g peak
Shock, non-operational				30	g peak
Vibration, sinusoidal, operational	IEC/EN 60068-2-6, sweep 5 to 500 to 5 Hz, 1 octave/min, 5 sweep per axis			1	g peak
Vibration, sinusoidal, non-operational				4	g peak
Vibration, random, non-operational		IEC/EN 60068-2-64, 5 to 500 Hz, 1 hour per axis			0.025

14. RELIABILITY

PARAMETER	DESCRIPTION / CONDITION	MIN	NOM	MAX	UNIT
MTBF	Mean time to failure	$T_A = 25^\circ\text{C}$, according Telcordia SR-332, issue 3, GB, confidence level = 90%		860	kh

15. MECHANICAL

PARAMETER	DESCRIPTION / CONDITION	MIN	NOM	MAX	UNIT
Dimensions	Width		73.5		mm
	Height		40.0		mm
	Depth		265.0		mm
m	Weight		1.1		kg

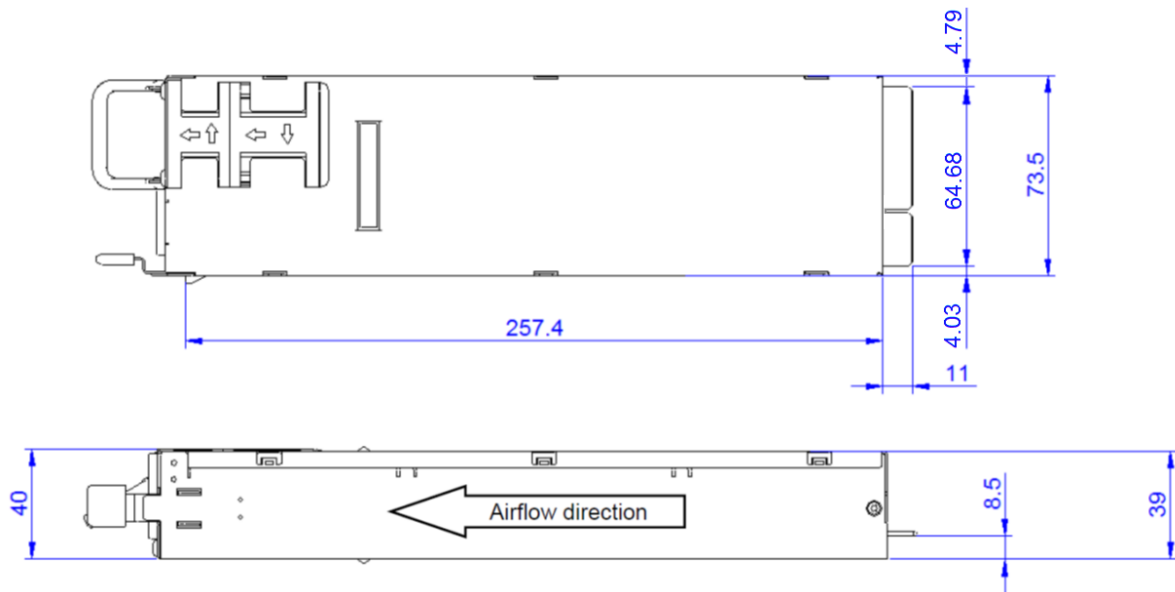

Figure 35. Top and side view

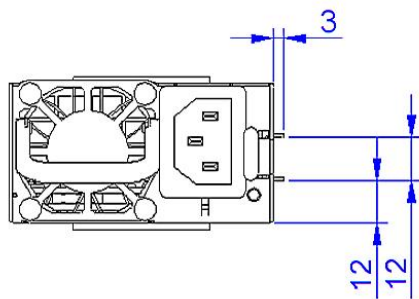

Figure 36. Front view

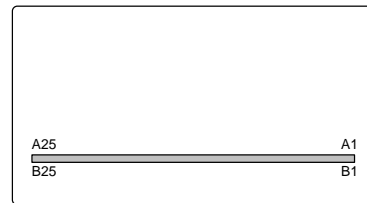

Figure 37. Rear view

16. CONNECTORS

PARAMETER	DESCRIPTION / CONDITION	MIN	NOM	MAX	UNIT
AC inlet	IEC 60320 C14				
AC cord requirement	Wire size		16		AWG
Output connector	25-Pin PCB card edge				
Mating output connector	FCI 10035388-106 or equivalent				

PIN	SIGNAL NAME	DESCRIPTION
A1 ~ A9	GND	Power and signal ground (return)
B1 ~ B9	GND	
A10 ~ A18	V1	+12 VDC main output
B10 ~ B18	V1	
A19	SDA	I ² C data signal line
A20	SCL	I ² C clock signal line
A21	PSON_L	Power supply on input, active-low
A22	SMB_ALERT_L	SMB Alert signal output, active-low
A23	V1_SENSE_R	Main output negative sense
A24	V1_SENSE	Main output positive sense
A25	PWOK_H	Power OK signal output, active-high
B19	A0	I ² C address selection input
B20	A1	
B21	VSB	+12 V Standby positive output
B22	HOTSTANDBYEN_L	Hot standby enable signal, active-high
B23	ISHARE	Analog current share bus
B24	PRESENT_L ⁷⁾	Power supply seated, active-low
B25	A2 ⁷⁾	I ² C address selection input

Table 5. Output connector pin assignment

⁷⁾ Available only on model PET1600-12-074NAS311, open circuit on standard model PET1600-12-074NA

17. ACCESSORIES

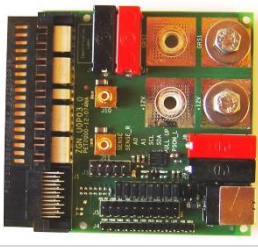
ITEM	DESCRIPTION	ORDERING PART NUMBER	SOURCE
	<p>I²C Utility Windows XP/Vista/7 compatible GUI to program, control and monitor PET1600-12-074NA Front-Ends (and other I²C units)</p>	ZS-00130	belfuse.com/power-solutions
	<p>Evaluation Board Connector board to operate PET1600-12-074NA. Includes an on-board USB to I²C converter (use I²C Utility as desktop software).</p>	YTM.00045	belfuse.com/power-solutions

For more information on these products consult: tech.support@psbel.com

NUCLEAR AND MEDICAL APPLICATIONS - Products are not designed or intended for use as critical components in life support systems, equipment used in hazardous environments, or nuclear control systems.

TECHNICAL REVISIONS - The appearance of products, including safety agency certifications pictured on labels, may change depending on the date manufactured. Specifications are subject to change without notice.



Asia-Pacific	Europe, Middle East	North America
+86 755 298 85888	+353 61 225 977	+1 408 785 5200

Данный компонент на территории Российской Федерации

Вы можете приобрести в компании MosChip.

Для оперативного оформления запроса Вам необходимо перейти по данной ссылке:

<http://moschip.ru/get-element>

Вы можете разместить у нас заказ для любого Вашего проекта, будь то серийное производство или разработка единичного прибора.

В нашем ассортименте представлены ведущие мировые производители активных и пассивных электронных компонентов.

Нашей специализацией является поставка электронной компонентной базы двойного назначения, продукции таких производителей как XILINX, Intel (ex.ALTERA), Vicor, Microchip, Texas Instruments, Analog Devices, Mini-Circuits, Amphenol, Glenair.

Сотрудничество с глобальными дистрибьюторами электронных компонентов, предоставляет возможность заказывать и получать с международных складов практически любой перечень компонентов в оптимальные для Вас сроки.

На всех этапах разработки и производства наши партнеры могут получить квалифицированную поддержку опытных инженеров.

Система менеджмента качества компании отвечает требованиям в соответствии с ГОСТ Р ИСО 9001, ГОСТ РВ 0015-002 и ЭС РД 009

Офис по работе с юридическими лицами:

105318, г.Москва, ул.Щербаковская д.3, офис 1107, 1118, ДЦ «Щербаковский»

Телефон: +7 495 668-12-70 (многоканальный)

Факс: +7 495 668-12-70 (доб.304)

E-mail: info@moschip.ru

Skype отдела продаж:

moschip.ru

moschip.ru_4

moschip.ru_6

moschip.ru_9