



PCF8577C

LCD direct/duplex driver with I²C-bus interface

Rev. 5 — 10 October 2014

Product data sheet

1. General description

The PCF8577C is an LCD driver which drives up to 32 segments directly, or 64 segments in a duplex configuration.

The two-line I²C-bus interface substantially reduces wiring overheads in remote display applications. I²C-bus traffic is minimized in multiple IC applications by automatic address incrementing, hardware subaddressing and display memory switching (direct drive mode). To allow partial V_{DD} shutdown, the ESD protection system of the SCL and SDA pins does not use a diode connected to V_{DD}.

For a selection of NXP LCD segment drivers, see [Table 13 on page 25](#).

2. Features and benefits

- Direct/duplex drive modes with up to 32/64 LCD-segment drive capability per device
- Operating supply voltage: 2.5 V to 6 V
- Low power consumption
- I²C-bus interface
- Optimized pinning for single plane wiring
- Single-pin built-in oscillator
- Auto-incremented loading across device subaddress boundaries
- Display memory switching in direct drive mode
- May be used as I²C-bus output expander
- System expansion up to 256 segments
- Power-on reset blanks display
- I²C-bus address: 0111 0100.

3. Ordering information

Table 1. Ordering information

Type number	Package		
	Name	Description	Version
PCF8577CT	VSO40	plastic very small outline package; 40 leads	SOT158-1



3.1 Ordering options

Table 2. Ordering options

Product type number	Orderable part number	Sales item (12NC)	Delivery form	IC revision
PCF8577CT/3	PCF8577CT/3,112	935278866112	tube	3
PCF8577CT/3	PCF8577CT/3,118	935278866118	tape and reel, 13 inch	3

4. Marking

Table 3. Marking codes

Type number	Marking code
PCF8577CT/3	PCF8577CT

5. Block diagram

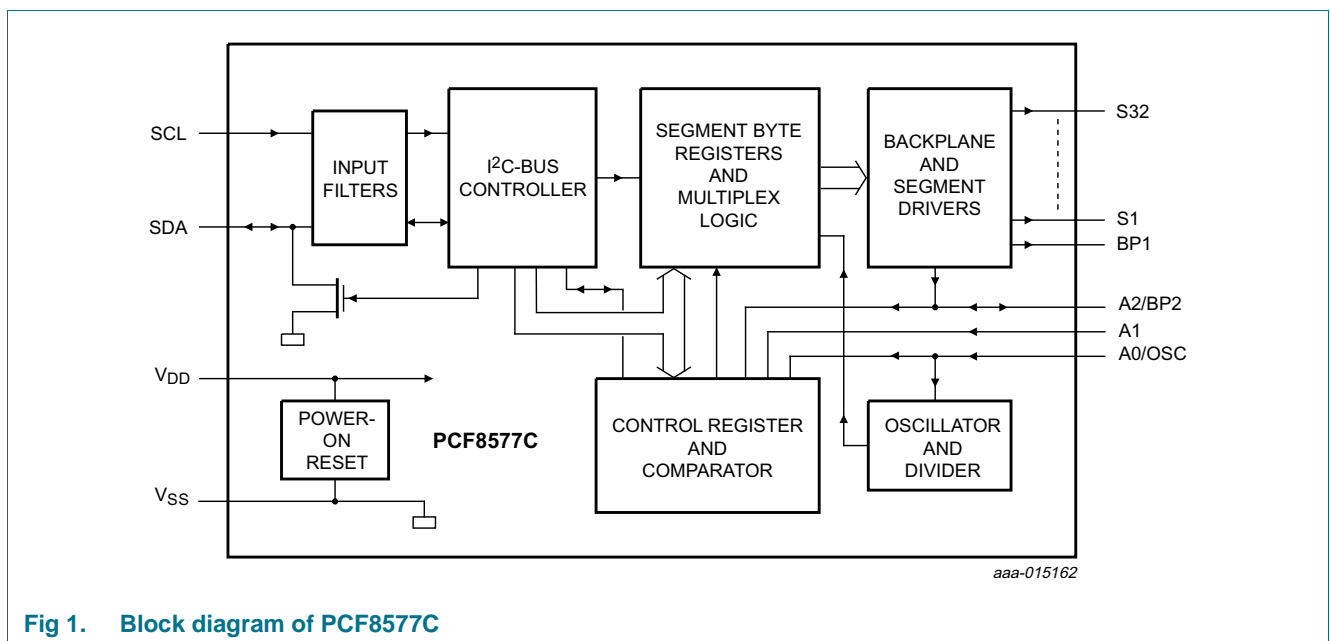

Fig 1. Block diagram of PCF8577C

6. Pinning information

6.1 Pinning

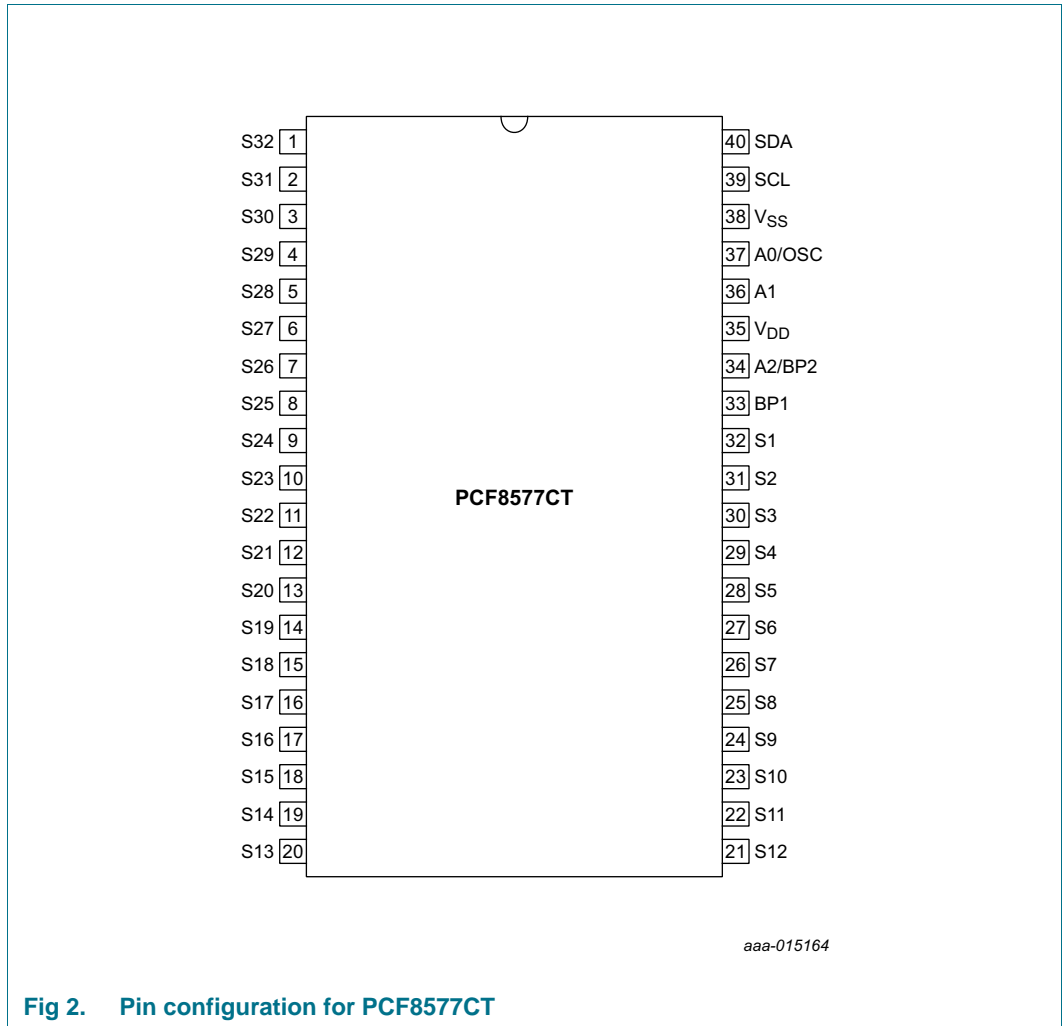

Fig 2. Pin configuration for PCF8577CT

6.2 Pin description

Table 4. Pin description

Symbol	Pin	Type	Description
S32 to S1	1 to 32	outputs	segment outputs
BP1	33	input/output	cascaded sync input/backplane output
A2/BP2	34	input/output	hardware address line and cascade sync input/backplane output
V _{DD}	35	supply	supply voltage
A1	36	input	hardware address line input
A0/OSC	37	input	hardware address line and oscillator pin input
V _{SS}	38	supply	ground supply
SCL	39	input	I ² C-bus clock line input
SDA	40	input/output	I ² C-bus data line input/output

7. Functional description

7.1 Hardware subaddress lines A0, A1, and A2

The hardware subaddress lines A0, A1, and A2 are used to program the device subaddress for each PCF8577C connected to the I²C-bus. Lines A0 and A2 are shared with OSC and BP2 respectively to reduce pinout requirements.

1. Line A0 is defined as LOW (logic 0) when this pin is used for the local oscillator or when connected to V_{SS}. Line A0 is defined as HIGH (logic 1) when connected to V_{DD}.
2. Line A1 must be defined as LOW (logic 0) or as HIGH (logic 1) by connection to V_{SS} or V_{DD} respectively.
3. In the direct drive mode, the second backplane signal BP2 is not used and the A2/BP2 pin is exclusively the A2 input. Line A2 is defined as LOW (logic 0) when connected to V_{SS} or, if this is not possible, by leaving it unconnected (internal pull-down). Line A2 is defined as HIGH (logic 1) when connected to V_{DD}.
4. In the duplex drive mode, the second backplane signal BP2 is required and the A2 signal is undefined. In this mode, device selection is made exclusively from lines A0 and A1.

7.2 Oscillator A0/OSC

The PCF8577C has a single-pin built-in oscillator which provides the modulation for the LCD segment driver outputs. One external resistor and one external capacitor are connected to the A0/OSC pin to form the oscillator (see [Figure 13](#) and [Figure 14](#)). For correct start-up of the oscillator after power-on, the resistor and capacitor must be connected to the same V_{SS}/V_{DD} as the chip. In an expanded system containing more than one PCF8577C the backplane signals are usually common to all devices and only one oscillator is required. The devices which are not used for the oscillator are put into the cascade mode by connecting the A0/OSC pin to either V_{DD} or V_{SS} depending on the required state for A0. In the cascade mode, each PCF8577C is synchronized from the backplane signals.

7.3 User-accessible registers

There are nine user-accessible 1-byte registers. The first is a control register which is used to control the loading of data into the segment byte registers and to select display options. The other eight are segment byte registers, split into two banks of storage, which store the segment data. The set of even-numbered segment byte registers is called BANK A. Odd-numbered segment byte registers are called BANK B.

There is one slave address for the PCF8577C (see Table 7). All addressed devices load the second byte into the control register and each device maintains an identical copy of the control byte in the control register always (see I²C-bus protocol, Figure 10), i.e. all addressed devices respond to control commands sent on the I²C-bus.

The control register is shown in more detail in Figure 3. The least-significant bits select which device and which segment byte register is loaded next. This part of the register is therefore called the Segment Byte Vector (SBV).

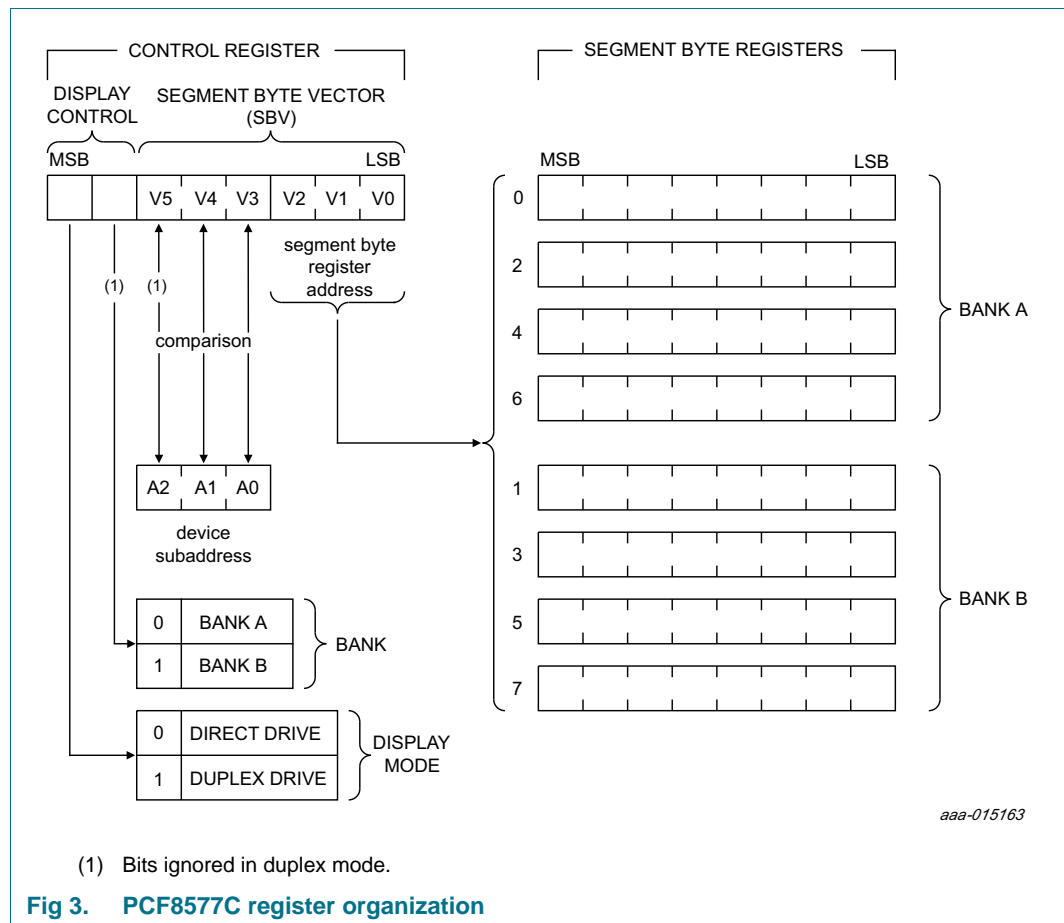

Fig 3. PCF8577C register organization

The upper three bits of the SBV (V5 to V3) are compared with the hardware subaddress input signals A2, A1 and A0. If they are the same, then the device is enabled for loading, if not the device ignores incoming data but remains active.

The three least-significant bits of the SBV (V2 to V0) address one of the segment byte registers within the enabled chip for loading segment data.

The control register also has two display control bits. These bits are named MODE and BANK. The MODE bit selects whether the display outputs are configured for direct or duplex drive displays. The BANK bit allows the user to display BANK A or BANK B.

7.4 Auto-incremented loading

After each segment byte is loaded, the SBV is incremented automatically. Thus auto-incremented loading occurs if more than one segment byte is received in a data transfer.

Since the SBV addresses both device and segment registers in all addressed chips, auto-incremented loading may proceed across device boundaries if the hardware subaddresses are arranged contiguously.

7.5 Direct drive mode

The PCF8577C is set to the direct drive mode by loading the MODE control bit with logic 0. In this mode, only four bytes are required to store the data for the 32 segment drivers. Setting the BANK bit to logic 0 selects even bytes (BANK A), setting the BANK bit to logic 1 selects odd bytes (BANK B).

In the direct drive mode, the SBV is auto-incremented by two after the loading of each segment byte register. This means, that auto-incremented loading of BANK A or BANK B is possible. Either bank may be completely or partially loaded irrespective of which bank is being displayed. Direct drive output waveforms are shown in [Figure 4](#).

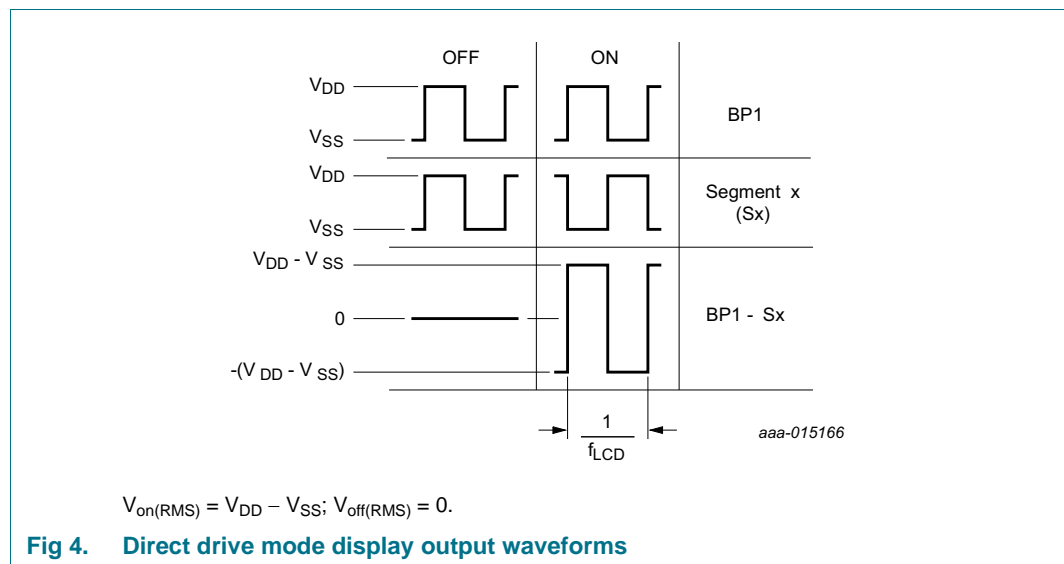

7.6 Duplex mode

The PCF8577C is set to the duplex mode by loading the MODE bit with logic 1. In this mode, a second backplane signal (BP2) is needed and pin A2/BP2 is used for this; therefore A2 and its equivalent SBV bit V5 are undefined. The SBV auto-increments by one between loaded bytes.

All of the segment bytes are required to store data for the 32 segment drivers and the BANK bit is ignored.

Duplex mode output waveforms are shown in [Figure 5](#).

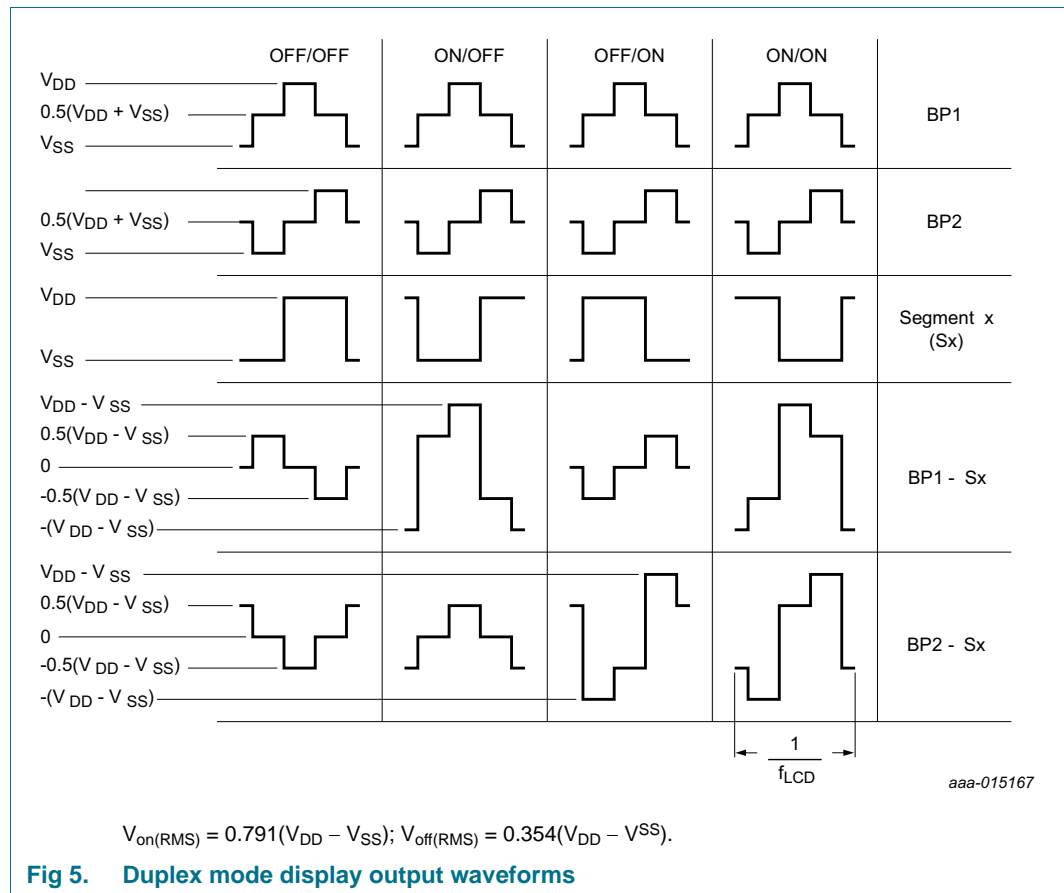

7.7 Display memory mapping

The mapping between the eight segment registers and the segment outputs S1 to S32 is given in [Table 5](#) and [Table 6](#).

Since only one register bit per segment is needed in the direct drive mode, the BANK bit allows swapping of display information. If BANK is set to logic 0, even bytes (BANK A) are displayed; if BANK is set to logic 1 odd bytes (BANK B) are displayed. BP1 is always used for the backplane output in the direct drive mode. In duplex mode, even bytes (BANK A) correspond to backplane 1 (BP1) and odd bytes (BANK B) correspond to backplane 2 (BP2).

Table 5. Segment byte-segment driver mapping in direct drive mode

Mode	Bank	V2	V1	V0	Segment/ Bit/ Register	7 MSB	6	5	4	3	2	1	0 LSB	Backplane
0	0	0	0	0	0	S8	S7	S6	S5	S4	S3	S2	S1	BP1
0	1	0	0	1	1	S8	S7	S6	S5	S4	S3	S2	S1	BP1
0	0	0	1	0	2	S16	S15	S14	S13	S12	S11	S10	S9	BP1
0	1	0	1	1	3	S16	S15	S14	S13	S12	S11	S10	S9	BP1
0	0	1	0	0	4	S24	S23	S22	S21	S20	S19	S18	S17	BP1
0	1	1	0	1	5	S24	S23	S22	S21	S20	S19	S18	S17	BP1
0	0	1	1	0	6	S32	S31	S30	S29	S28	S27	S26	S25	BP1
0	1	1	1	1	7	S32	S31	S30	S29	S28	S27	S26	S25	BP1

Mapping example: bit 0 of register 7 controls the LCD segment S25 if BANK bit is a logic 1.

Table 6. Segment byte-segment driver mapping in duplex mode

Mode	Bank	V2	V1	V0	Segment/ Bit/ Register	7 MSB	6	5	4	3	2	1	0 LSB	Backplane
1	X ^[1]	0	0	0	0	S8	S7	S6	S5	S4	S3	S2	S1	BP1
1	X ^[1]	0	0	1	1	S8	S7	S6	S5	S4	S3	S2	S1	BP2
1	X ^[1]	0	1	0	2	S16	S15	S14	S13	S12	S11	S10	S9	BP1
1	X ^[1]	0	1	1	3	S16	S15	S14	S13	S12	S11	S10	S9	BP2
1	X ^[1]	1	0	0	4	S24	S23	S22	S21	S20	S19	S18	S17	BP1
1	X ^[1]	1	0	1	5	S24	S23	S22	S21	S20	S19	S18	S17	BP2
1	X ^[1]	1	1	0	6	S32	S31	S30	S29	S28	S27	S26	S25	BP1
1	X ^[1]	1	1	1	7	S32	S31	S30	S29	S28	S27	S26	S25	BP2

[1] Don't care.

Mapping example: bit 7 of register 5 controls the LCD segment S24/BP2.

7.8 Power-on reset

At power-on reset the PCF8577C resets to a defined starting condition as follows:

1. Both backplane outputs are set to V_{SS} in master mode; to 3-state in cascade mode
2. All segment outputs are set to V_{SS}
3. The segment byte registers and control register are cleared
4. The I²C-bus interface is initialized.

8. I²C-bus interface

8.1 Characteristics of the I²C-Bus

The I²C-bus is for 2-way, 2-line communication between different ICs or modules. The two lines are a Serial DATA line (SDA) and a Serial CLOCK line (SCL). Both lines must be connected to a positive supply via a pull-up resistor when connected to the output stages of a device. Data transfer may be initiated only when the I²C-bus is not busy.

8.1.1 Bit transfer

One data bit is transferred during each clock pulse. The data on the SDA line must remain stable during the HIGH period of the clock pulse as changes in the data line at this time are interpreted as control signals.

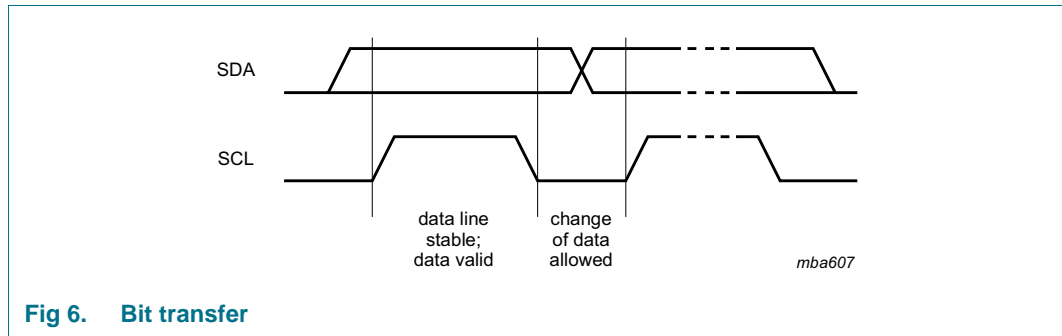

Fig 6. Bit transfer

8.1.2 START and STOP conditions

Both data and clock lines remain HIGH when the I²C-bus is not busy. A HIGH-to-LOW transition of the data line, while the clock is HIGH is defined as the START condition (S). A LOW-to-HIGH transition of the data line while the clock is HIGH is defined as the STOP condition (P).

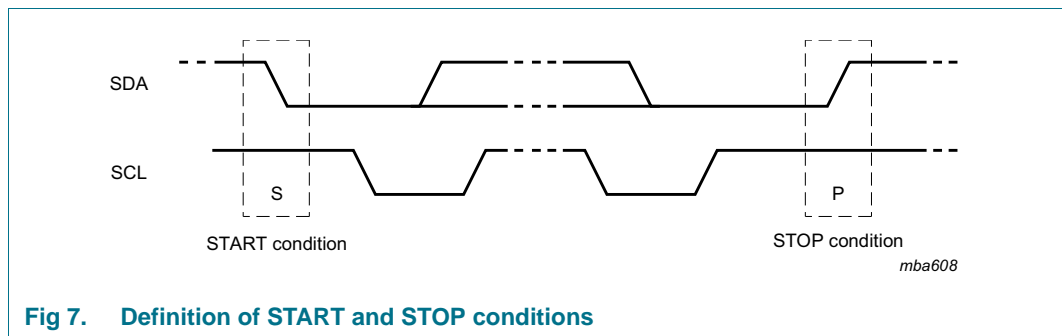

Fig 7. Definition of START and STOP conditions

8.1.3 System configuration

A device generating a message is a 'transmitter', a device receiving a message is the 'receiver'. The device that controls the message is the 'master' and the devices which are controlled by the master are the 'slaves'.

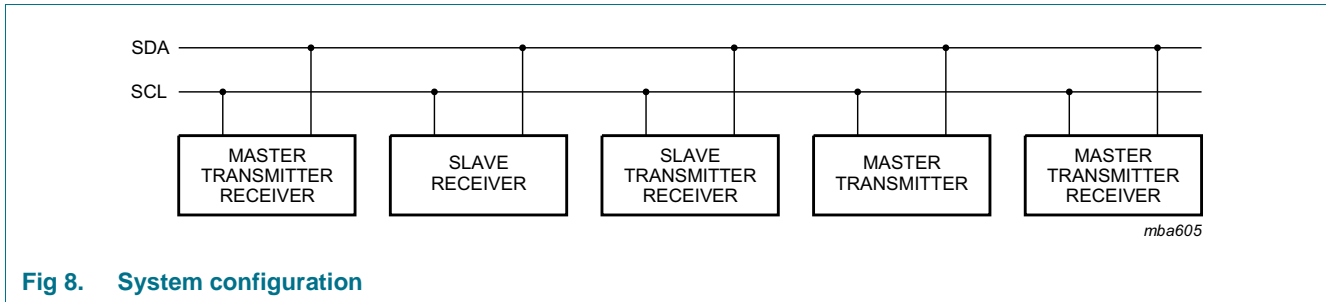

Fig 8. System configuration

8.1.4 Acknowledge

The number of data bytes transferred between the START and STOP conditions from transmitter to receiver is not limited. Each byte is followed by one acknowledge bit. The acknowledge bit is a HIGH level put on the I²C-bus by the transmitter whereas the master generates an extra acknowledge related clock pulse. A slave receiver which is addressed must generate an acknowledge after the reception of each byte. Also a master must generate an acknowledge after the reception of each byte that has been clocked out of the slave transmitter. The device that acknowledges has to pull down the SDA line during the acknowledge clock pulse, set-up and hold times must be taken into account. A master receiver must signal an end of data to the transmitter by not generating an acknowledge on the last byte that has been clocked out of the slave. In this event, the transmitter must leave the data line HIGH to enable the master to generate a STOP condition.

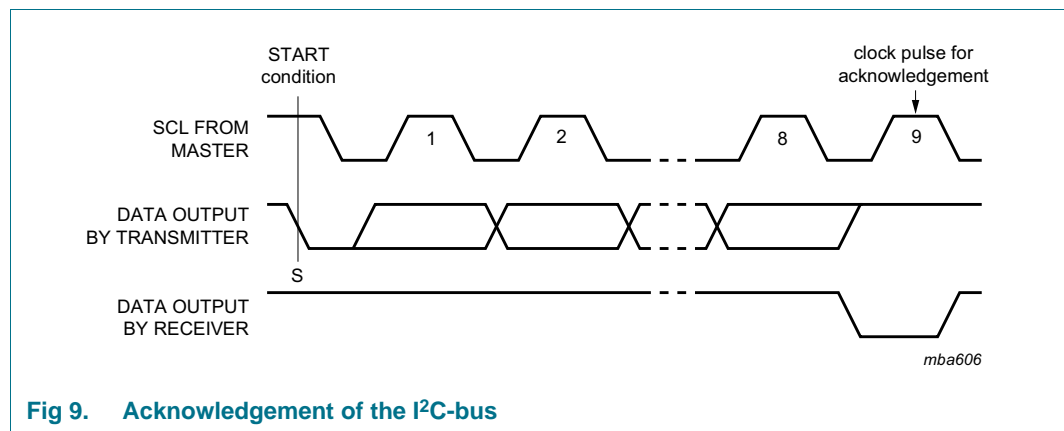

Fig 9. Acknowledgement of the I²C-bus

8.2 Slave address

The PCF8577C slave address is shown in [Table 7](#).

Table 7. I²C slave address byte

Bit	Slave address							R/W
	7 MSB	6	5	4	3	2	1	0 LSB
	0	1	1	1	0	1	0	0

Before any data is transmitted on the I²C-bus, the device which should respond is addressed first. The addressing is always done with the first byte transmitted after the start procedure.

8.3 I²C-bus protocol

The PCF8577C I²C-bus protocol is shown in [Figure 10](#).

The PCF8577C is a slave receiver and has a fixed slave address (see [Table 7](#)). All PCF8577Cs with the same slave address acknowledge the slave address in parallel.

The second byte is always the control byte and is loaded into the control register of each PCF8577C connected to the I²C-bus. All addressed devices acknowledge the control byte. Subsequent data bytes are loaded into the segment registers of the selected device. Any number of data bytes may be loaded in one transfer and in an expanded system rollover of the SBV from 111 111 to 000 000 is allowed. If a STOP (P) condition is given after the control byte acknowledge, the segment data remains unchanged. This allows the BANK bit to be toggled without changing the segment register contents. During loading of segment data, only the selected PCF8577C gives an acknowledge. Loading is terminated by generating a STOP (P) condition.

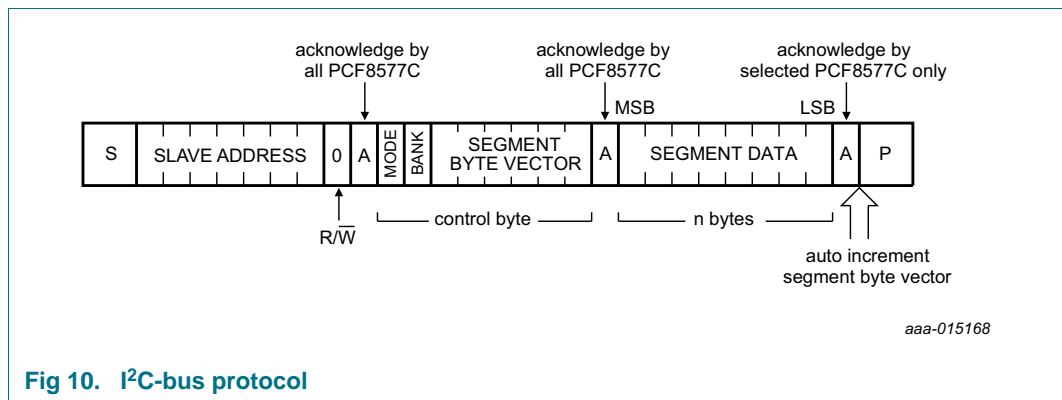

Fig 10. I²C-bus protocol

9. Safety notes

CAUTION



This device is sensitive to ElectroStatic Discharge (ESD). Observe precautions for handling electrostatic sensitive devices.

Such precautions are described in the *ANSI/ESD S20.20*, *IEC/ST 61340-5*, *JESD625-A* or equivalent standards.

CAUTION



Static voltages across the liquid crystal display can build up when the LCD supply voltage (V_{LCD}) is on while the IC supply voltage (V_{DD}) is off, or vice versa. This may cause unwanted display artifacts. To avoid such artifacts, V_{LCD} and V_{DD} must be applied or removed together.

CAUTION



Semiconductors are light sensitive. Exposure to light sources can cause the IC to malfunction. The IC must be protected against light. The protection must be applied to all sides of the IC.

10. Limiting values

Table 8. Limiting values

In accordance with the Absolute Maximum Rating System (IEC 60134).

Symbol	Parameter	Conditions	Min	Max	Unit
V _{DD}	supply voltage		-0.5	+8.0	V
V _{LCD}	LCD supply voltage		[1] V _{DD} - 8.0	V _{DD}	V
V _I	input voltage		-0.5	V _{DD} + 0.5	V
V _O	output voltage	on each of the pins S1 to S32 and BP1 and BP2	[1] -0.5	+8.0	V
I _I	input current		-20	+20	mA
I _O	output current		-25	+25	mA
I _{DD}	supply current		-50	+50	mA
I _{SS}	ground supply current		-50	+50	mA
I _{DD(LCD)}	LCD supply current		-50	+50	mA
P _{tot}	total power dissipation		-	500	mW
P _o	output power		-	100	mW
V _{ESD}	electrostatic discharge voltage	HBM	[2] -	±2000	V
		MM	[3] -	±200	V
I _{Iu}	latch-up current		[4] -	100	mA
T _{stg}	storage temperature		[5] -65	+150	°C
T _{amb}	ambient temperature	operating device	-40	+85	°C

[1] Values with respect to V_{DD}.

[2] Pass level; Human Body Model (HBM), according to [Ref. 6 "JESD22-A114"](#).

[3] Pass level; Machine Model (MM), according to [Ref. 7 "JESD22-A115"](#).

[4] Pass level; latch-up testing according to [Ref. 8 "JESD78"](#) at maximum ambient temperature (T_{amb(max)}).

[5] According to the store and transport requirements (see [Ref. 12 "UM10569"](#)) the devices have to be stored at a temperature of +8 °C to +45 °C and a humidity of 25 % to 75 %.

11. Static characteristics

Table 9. Static characteristics
 $V_{DD} = 2.5\text{ V to }6\text{ V}; V_{SS} = 0\text{ V}; T_{amb} = -40\text{ }^{\circ}\text{C to }85\text{ }^{\circ}\text{C};$ unless otherwise specified.

Symbol	Parameter	Conditions	Min	Typ	Max	Unit		
Supplies								
V_{DD}	supply voltage		2.5	-	6	V		
I_{DD}	supply current	no load; $R_{OSC} = 1\text{ M}\Omega$; $C_{OSC} = 680\text{ pF}$	[1]					
		$f_{SCL} = 100\text{ kHz}$	[1]	-	50	125	μA	
		$f_{SCL} = 0\text{ Hz}$	[1]	-	25	75	μA	
		$V_{DD} = 5\text{ V};$ $T_{amb} = 25\text{ }^{\circ}\text{C}$	[1]	-	25	40	μA	
I_{DD}	supply current	no load; $f_{SCL} = 0\text{ Hz};$ $A0/OSC = V_{DD};$ $V_{DD} = 5\text{ V};$ $T_{amb} = 25\text{ }^{\circ}\text{C}$	[1]	-	10	20	μA	
			[2]	-	1.1	2.0	V	
		Logic						
		V_{IL}	LOW-level input voltage	on pin A0	0	-	0.05	V
on pins A1, SCL, SDA	0			-	$0.3V_{DD}$	V		
on pin A2	0			-	0.1	V		
V_{IH}	HIGH-level input voltage	on pin A0	$V_{DD} - 0.05$	-	V_{DD}	V		
		on pin A1	$0.7V_{DD}$	-	V_{DD}	V		
		on pin A2	$V_{DD} - 0.1$	-	V_{DD}	V		
		on pins SCL, SDA	$0.7V_{DD}$	-	6	V		
C_i	input capacitance		[3]	-	7	pF		
I_{OL}	LOW-level output current	output sink current; on pin SDA; $V_{OL} = 0.4\text{ V};$ $V_{DD} = 5\text{ V};$	3	-	-	mA		
I_L	leakage current	$V_I = V_{DD}$ or V_{SS}						
		on pins A1, SCL, SDA	-1	-	+1	μA		
		on pins A2/BP2, BP1	-5	-	+5	μA		
		$V_I = V_{DD};$ on pin A0/OSC	-1	-	-	μA		
I_{pd}	pull-down current	$V_I = V_{DD};$ on pin A2/BP2	-5	-1.5	-	μA		
$I_{startup}$	startup current	oscillator; $V_I = V_{SS}$	-	1.2	5	μA		

Table 9. Static characteristics ...continued $V_{DD} = 2.5\text{ V to }6\text{ V}$; $V_{SS} = 0\text{ V}$; $T_{amb} = -40\text{ }^{\circ}\text{C to }85\text{ }^{\circ}\text{C}$; unless otherwise specified.

Symbol	Parameter	Conditions	Min	Typ	Max	Unit
LCD outputs						
V_{DC}	DC component of LCD driver		-	± 20	-	mV
I_{OL}	LOW-level output current	on pins S1 to S32; $V_{DD} = 5\text{ V}$; $V_{OL} = 0.8\text{ V}$	[4] 0.3	-	-	mA
I_{OH}	HIGH-level output current	on pins S1 to S32; $V_{DD} = 5\text{ V}$; $V_{OH} = V_{DD} - 0.8\text{ V}$	[4] -	-	-0.3	mA
R_o	output resistance	on pins BP1, BP2; $V_o = V_{SS}$ or V_{DD} or $\frac{1}{2}(V_{SS} + V_{DD})$	[5] -	0.4	5	k Ω

[1] Inputs at V_{SS} or V_{DD} .[2] Resets all logic when $V_{DD} < V_{POR}$.

[3] Periodically sampled, not 100 % tested.

[4] Outputs measured one at a time.

[5] Outputs measured one at a time; $V_{DD} = 5\text{ V}$; $I_{load} = 100\text{ }\mu\text{A}$.

12. Dynamic characteristics

Table 10. Dynamic characteristics

$V_{DD} = 2.5\text{ V to }6\text{ V}$; $V_{SS} = 0\text{ V}$; $T_{amb} = -40\text{ °C to }85\text{ °C}$; unless otherwise specified. All the timing values are valid within the operating supply voltage and ambient temperature range and refer to V_{IL} and V_{IH} with an input voltage swing of V_{SS} to V_{DD} .

Symbol	Parameter	Conditions	Min	Typ ^[1]	Max	Unit
f _{LCD}	display frequency	R _{OSC} = 1 MΩ; C _{OSC} = 680 pF	65	90	120	Hz
t _{BS}	driver delays with test loads	V _{DD} = 5 V [2]	-	20	100	μs
I²C-bus						
f _{SCL}	SCL clock frequency		-	-	100	kHz
t _{SW}	tolerable spike width on I ² C-bus	T _{amb} = 25 °C	-	-	100	ns
t _{BUF}	bus free time between a STOP and START condition		4.7	-	-	μs
t _{SU;STA}	set-up time for a repeated START condition		4.0	-	-	μs
t _{HD;STA}	hold time (repeated) START condition		4.0	-	-	μs
t _{LOW}	LOW period of the SCL clock		4.7	-	-	μs
t _{HIGH}	HIGH period of the SCL clock		4.0	-	-	μs
t _r	rise time of both SDA and SCL signals		-	-	1.0	μs
t _f	fall time of both SDA and SCL signals		-	-	0.3	μs
t _{SU;DAT}	data set-up time		250	-	-	ns
t _{HD;DAT}	data hold time		0	-	-	ns
t _{SU;STO}	set-up time for STOP condition		4.0	-	-	μs

[1] Typical conditions: $V_{DD} = 5\text{ V}$; $T_{amb} = 25\text{ °C}$.

[2] Test loads:.

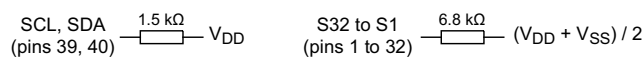

aaa-015184

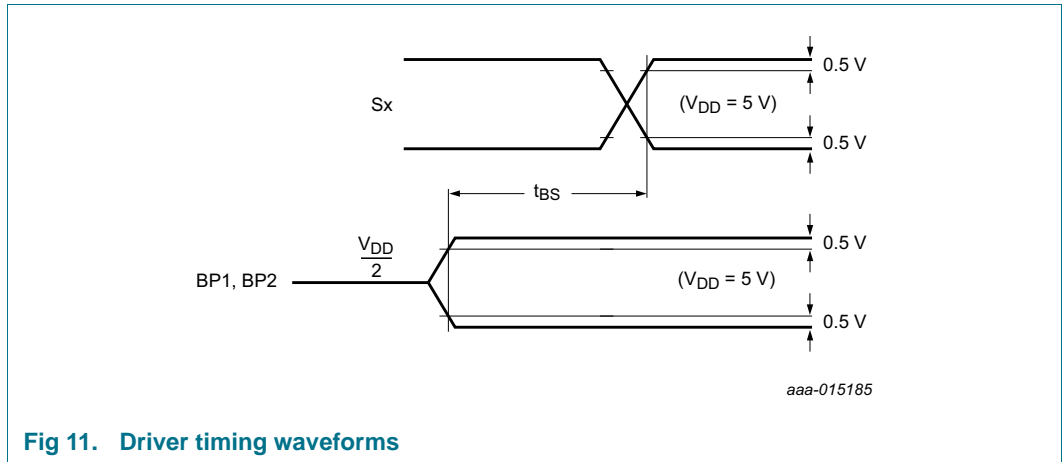

Fig 11. Driver timing waveforms

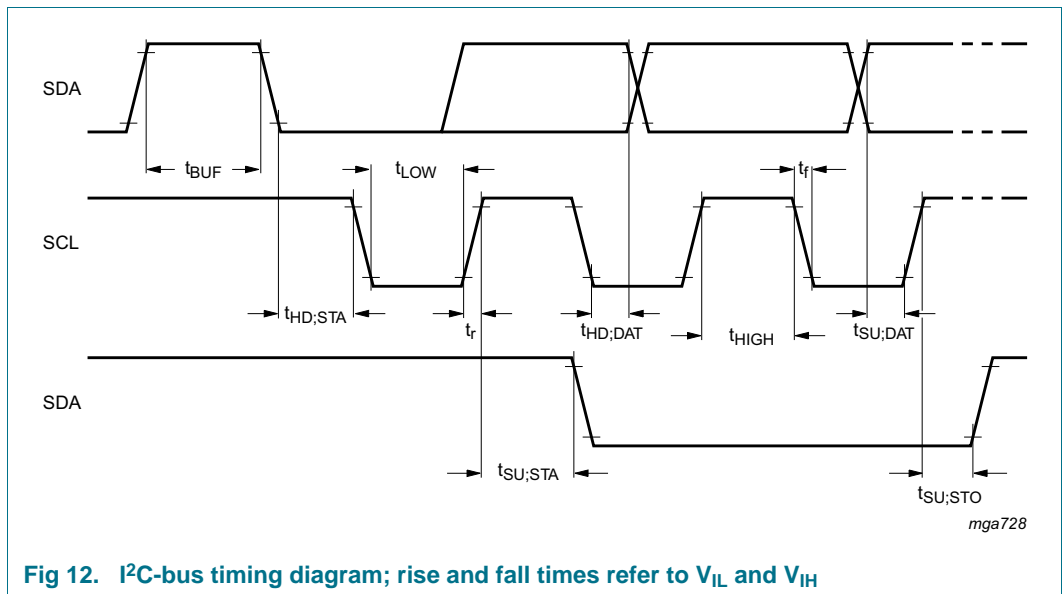
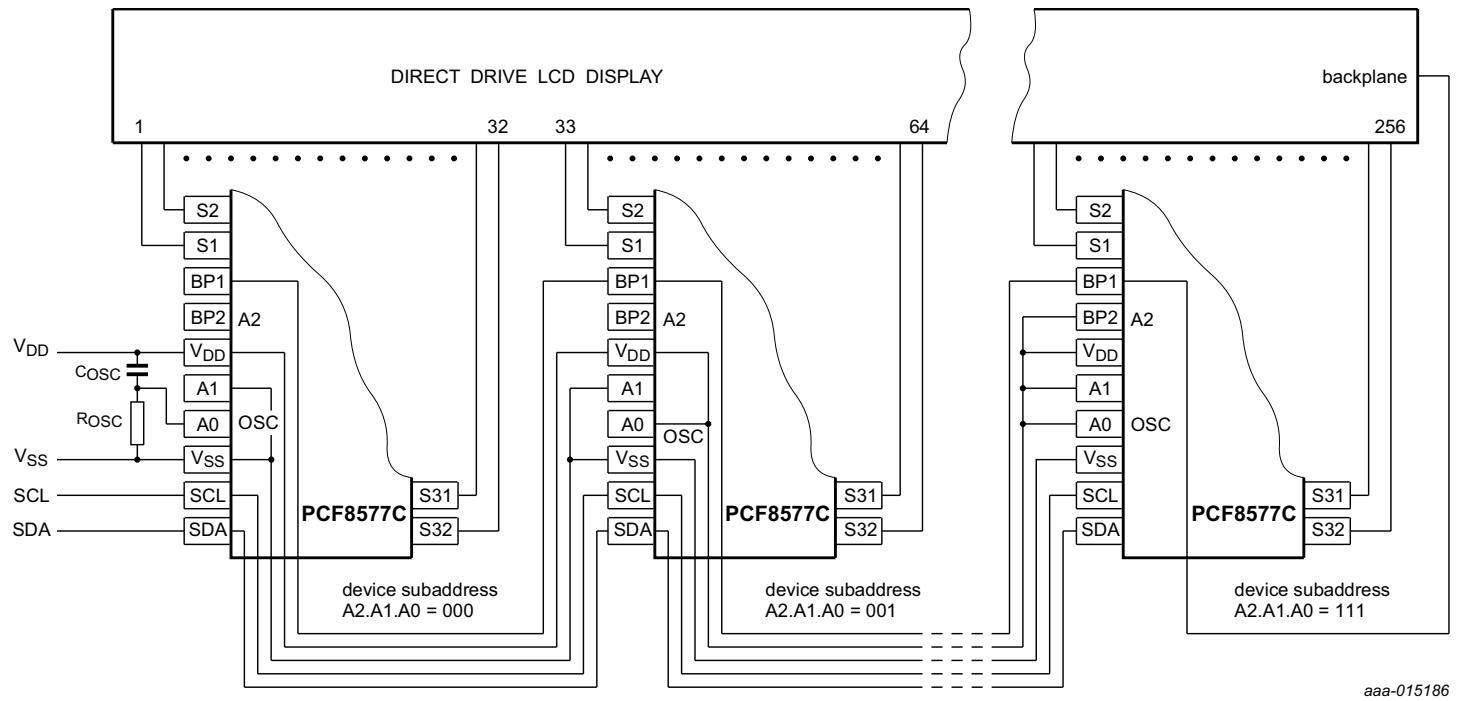

Fig 12. I²C-bus timing diagram; rise and fall times refer to V_{IL} and V_{IH}



aaa-015186

13. Application information

Fig 13. Direct display driver; expansion to 256 segments using eight PCF8577Cs

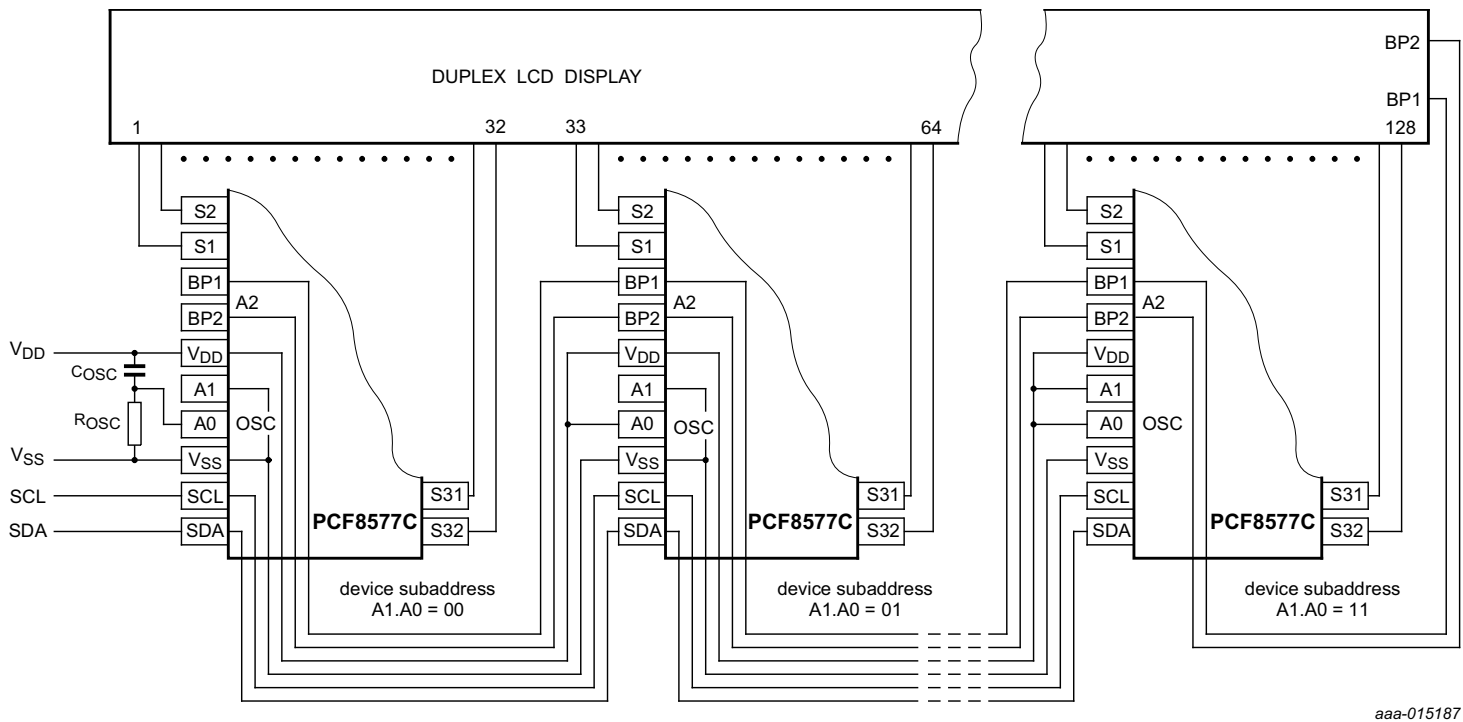

aaa-015187

Fig 14. Duplex display; expansion to 2 × 128 segments using four PCF8577Cs

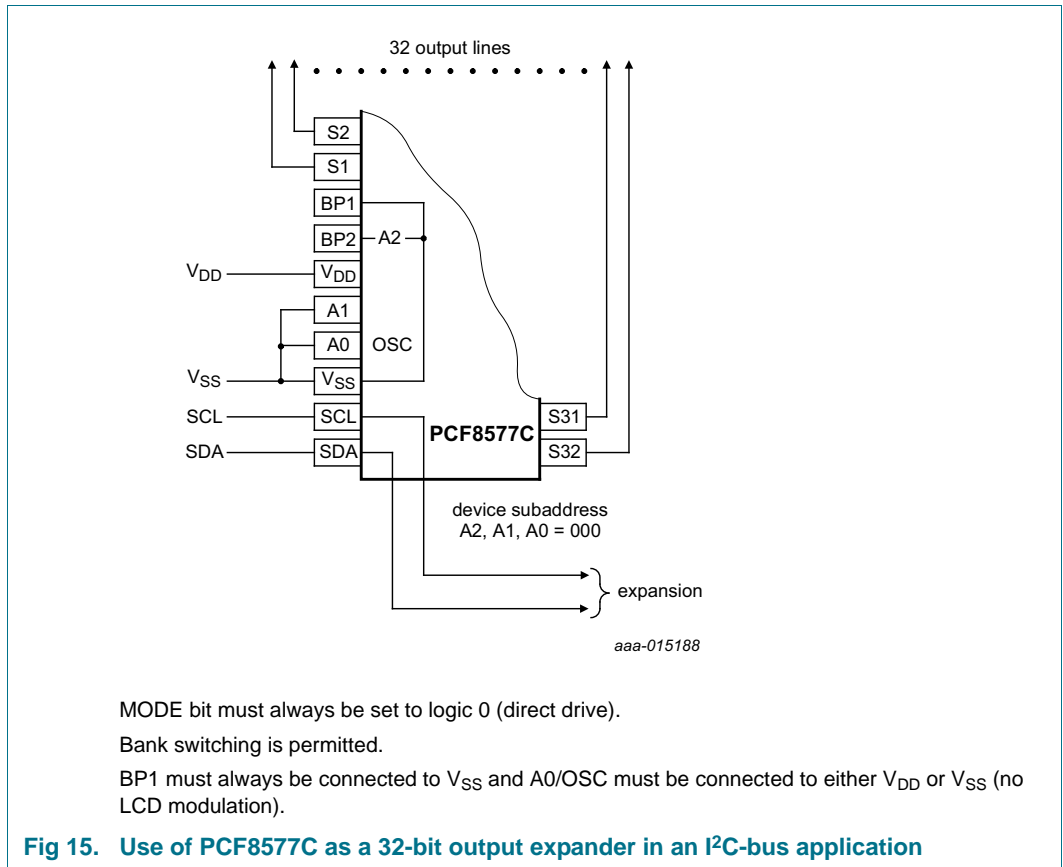

14. Package outline

VSO40: plastic very small outline package; 40 leads

SOT158-1

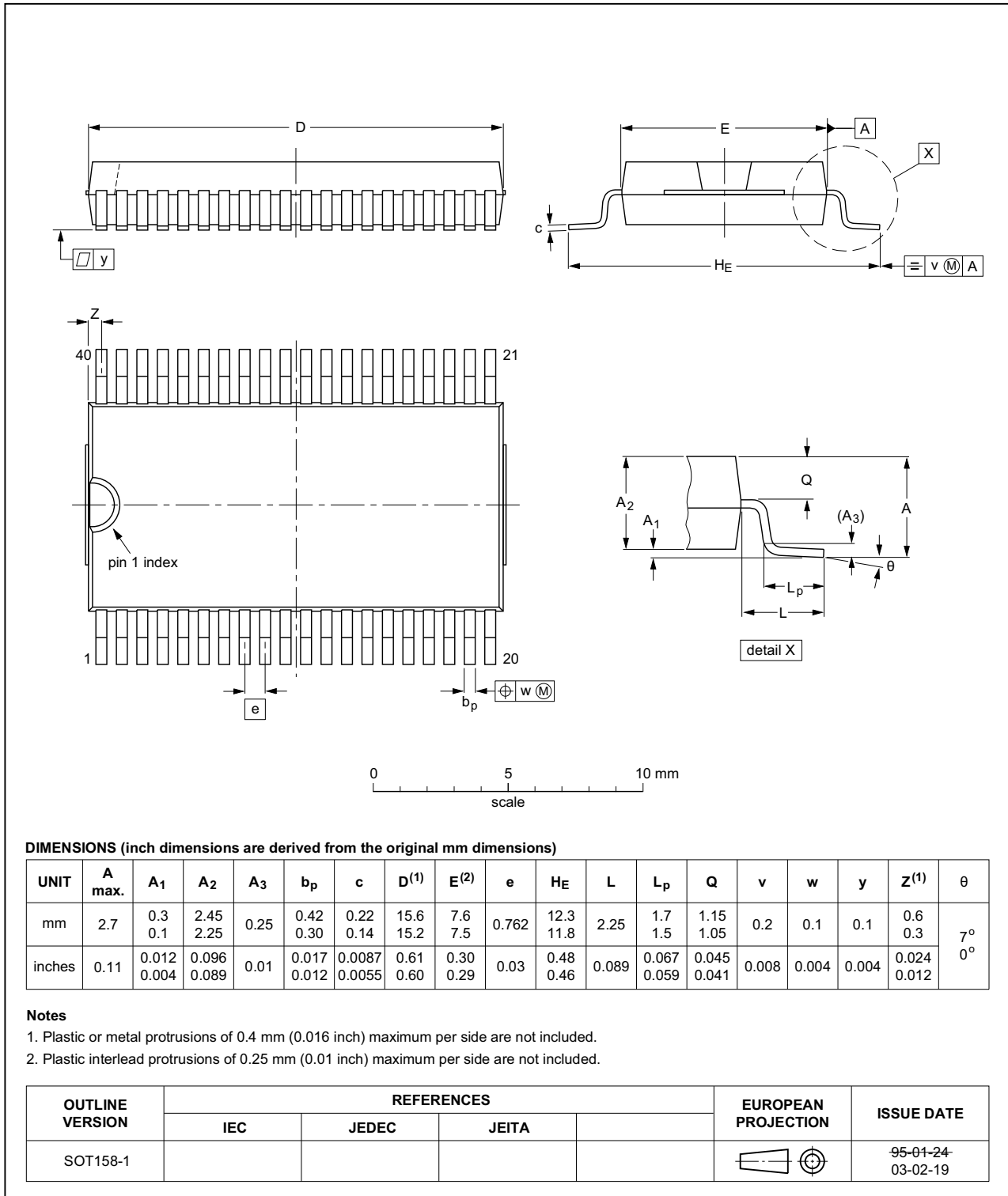

Fig 16. Package outline SOT158-1 (VSO40) of PCF8577CT

15. Packing information

15.1 Tape and reel information

For tape and reel packing information, see [Ref. 10 "SOT158-1_118" on page 27](#).

16. Soldering of SMD packages

This text provides a very brief insight into a complex technology. A more in-depth account of soldering ICs can be found in Application Note *AN10365 "Surface mount reflow soldering description"*.

16.1 Introduction to soldering

Soldering is one of the most common methods through which packages are attached to Printed Circuit Boards (PCBs), to form electrical circuits. The soldered joint provides both the mechanical and the electrical connection. There is no single soldering method that is ideal for all IC packages. Wave soldering is often preferred when through-hole and Surface Mount Devices (SMDs) are mixed on one printed wiring board; however, it is not suitable for fine pitch SMDs. Reflow soldering is ideal for the small pitches and high densities that come with increased miniaturization.

16.2 Wave and reflow soldering

Wave soldering is a joining technology in which the joints are made by solder coming from a standing wave of liquid solder. The wave soldering process is suitable for the following:

- Through-hole components
- Leaded or leadless SMDs, which are glued to the surface of the printed circuit board

Not all SMDs can be wave soldered. Packages with solder balls, and some leadless packages which have solder lands underneath the body, cannot be wave soldered. Also, leaded SMDs with leads having a pitch smaller than ~0.6 mm cannot be wave soldered, due to an increased probability of bridging.

The reflow soldering process involves applying solder paste to a board, followed by component placement and exposure to a temperature profile. Leaded packages, packages with solder balls, and leadless packages are all reflow solderable.

Key characteristics in both wave and reflow soldering are:

- Board specifications, including the board finish, solder masks and vias
- Package footprints, including solder thieves and orientation
- The moisture sensitivity level of the packages
- Package placement
- Inspection and repair
- Lead-free soldering versus SnPb soldering

16.3 Wave soldering

Key characteristics in wave soldering are:

- Process issues, such as application of adhesive and flux, clinching of leads, board transport, the solder wave parameters, and the time during which components are exposed to the wave
- Solder bath specifications, including temperature and impurities

16.4 Reflow soldering

Key characteristics in reflow soldering are:

- Lead-free versus SnPb soldering; note that a lead-free reflow process usually leads to higher minimum peak temperatures (see [Figure 17](#)) than a SnPb process, thus reducing the process window
- Solder paste printing issues including smearing, release, and adjusting the process window for a mix of large and small components on one board
- Reflow temperature profile; this profile includes preheat, reflow (in which the board is heated to the peak temperature) and cooling down. It is imperative that the peak temperature is high enough for the solder to make reliable solder joints (a solder paste characteristic). In addition, the peak temperature must be low enough that the packages and/or boards are not damaged. The peak temperature of the package depends on package thickness and volume and is classified in accordance with [Table 11](#) and [12](#)

Table 11. SnPb eutectic process (from J-STD-020D)

Package thickness (mm)	Package reflow temperature (°C)	
	Volume (mm ³)	
	< 350	≥ 350
< 2.5	235	220
≥ 2.5	220	220

Table 12. Lead-free process (from J-STD-020D)

Package thickness (mm)	Package reflow temperature (°C)		
	Volume (mm ³)		
	< 350	350 to 2000	> 2000
< 1.6	260	260	260
1.6 to 2.5	260	250	245
> 2.5	250	245	245

Moisture sensitivity precautions, as indicated on the packing, must be respected at all times.

Studies have shown that small packages reach higher temperatures during reflow soldering, see [Figure 17](#).

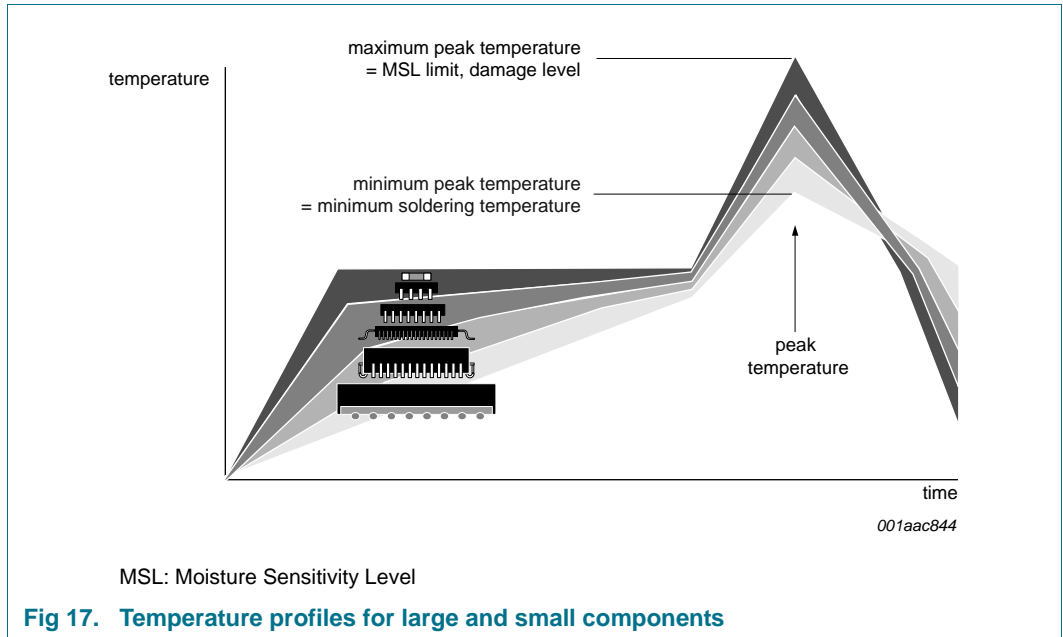

For further information on temperature profiles, refer to Application Note AN10365 “Surface mount reflow soldering description”.

17. Footprint information

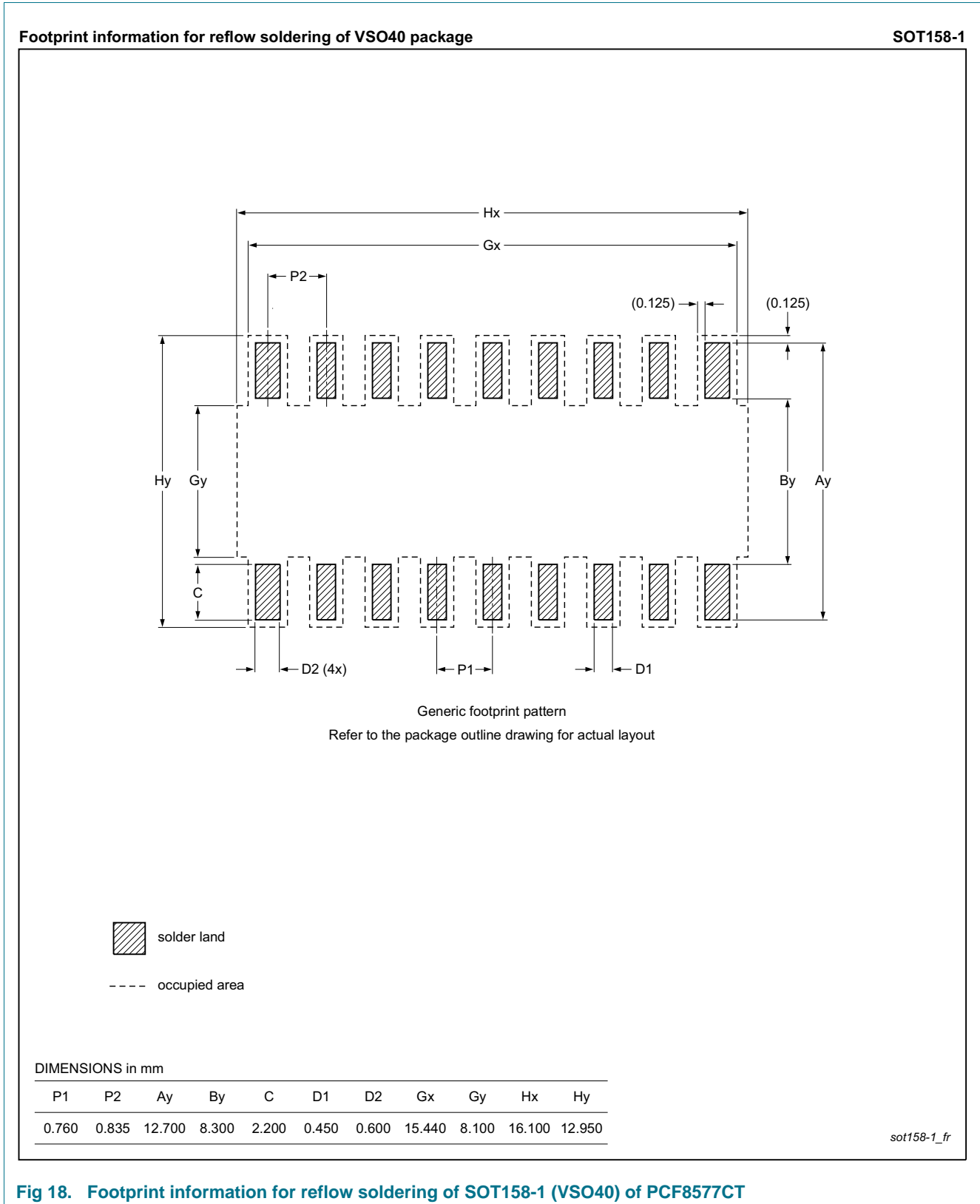

Fig 18. Footprint information for reflow soldering of SOT158-1 (VSO40) of PCF8577C

18. Appendix

18.1 LCD segment driver selection

Table 13. Selection of LCD segment drivers

Type name	Number of elements at MUX							V _{DD} (V)	V _{LCD} (V)	f _{fr} (Hz)	V _{LCD} (V) charge pump	V _{LCD} (V) temperature compensat.	T _{amb} (°C)	Interface	Package	AEC- Q100
	1:1	1:2	1:3	1:4	1:6	1:8	1:9									
PCA8553DTT	40	80	120	160	-	-	-	1.8 to 5.5	1.8 to 5.5	32 to 256 ^[1]	N	N	-40 to 105	I ² C / SPI	TSSOP56	Y
PCA8546ATT	-	-	-	176	-	-	-	1.8 to 5.5	2.5 to 9	60 to 300 ^[1]	N	N	-40 to 95	I ² C	TSSOP56	Y
PCA8546BTT	-	-	-	176	-	-	-	1.8 to 5.5	2.5 to 9	60 to 300 ^[1]	N	N	-40 to 95	SPI	TSSOP56	Y
PCA8547AHT	44	88	-	176	-	-	-	1.8 to 5.5	2.5 to 9	60 to 300 ^[1]	Y	Y	-40 to 95	I ² C	TQFP64	Y
PCA8547BHT	44	88	-	176	-	-	-	1.8 to 5.5	2.5 to 9	60 to 300 ^[1]	Y	Y	-40 to 95	SPI	TQFP64	Y
PCF85134HL	60	120	180	240	-	-	-	1.8 to 5.5	2.5 to 6.5	82	N	N	-40 to 85	I ² C	LQFP80	N
PCA85134H	60	120	180	240	-	-	-	1.8 to 5.5	2.5 to 8	82	N	N	-40 to 95	I ² C	LQFP80	Y
PCA8543AHL	60	120	-	240	-	-	-	2.5 to 5.5	2.5 to 9	60 to 300 ^[1]	Y	Y	-40 to 105	I ² C	LQFP80	Y
PCF8545ATT	-	-	-	176	252	320	-	1.8 to 5.5	2.5 to 5.5	60 to 300 ^[1]	N	N	-40 to 85	I ² C	TSSOP56	N
PCF8545BTT	-	-	-	176	252	320	-	1.8 to 5.5	2.5 to 5.5	60 to 300 ^[1]	N	N	-40 to 85	SPI	TSSOP56	N
PCF8536AT	-	-	-	176	252	320	-	1.8 to 5.5	2.5 to 9	60 to 300 ^[1]	N	N	-40 to 85	I ² C	TSSOP56	N
PCF8536BT	-	-	-	176	252	320	-	1.8 to 5.5	2.5 to 9	60 to 300 ^[1]	N	N	-40 to 85	SPI	TSSOP56	N
PCA8536AT	-	-	-	176	252	320	-	1.8 to 5.5	2.5 to 9	60 to 300 ^[1]	N	N	-40 to 95	I ² C	TSSOP56	Y
PCA8536BT	-	-	-	176	252	320	-	1.8 to 5.5	2.5 to 9	60 to 300 ^[1]	N	N	-40 to 95	SPI	TSSOP56	Y
PCF8537AH	44	88	-	176	276	352	-	1.8 to 5.5	2.5 to 9	60 to 300 ^[1]	Y	Y	-40 to 85	I ² C	TQFP64	N
PCF8537BH	44	88	-	176	276	352	-	1.8 to 5.5	2.5 to 9	60 to 300 ^[1]	Y	Y	-40 to 85	SPI	TQFP64	N
PCA8537AH	44	88	-	176	276	352	-	1.8 to 5.5	2.5 to 9	60 to 300 ^[1]	Y	Y	-40 to 95	I ² C	TQFP64	Y
PCA8537BH	44	88	-	176	276	352	-	1.8 to 5.5	2.5 to 9	60 to 300 ^[1]	Y	Y	-40 to 95	SPI	TQFP64	Y
PCA9620H	60	120	-	240	320	480	-	2.5 to 5.5	2.5 to 9	60 to 300 ^[1]	Y	Y	-40 to 105	I ² C	LQFP80	Y
PCA9620U	60	120	-	240	320	480	-	2.5 to 5.5	2.5 to 9	60 to 300 ^[1]	Y	Y	-40 to 105	I ² C	Bare die	Y
PCF8576DU	40	80	120	160	-	-	-	1.8 to 5.5	2.5 to 6.5	77	N	N	-40 to 85	I ² C	Bare die	N
PCF8576EUG	40	80	120	160	-	-	-	1.8 to 5.5	2.5 to 6.5	77	N	N	-40 to 85	I ² C	Bare die	N
PCA8576FUG	40	80	120	160	-	-	-	1.8 to 5.5	2.5 to 8	200	N	N	-40 to 105	I ² C	Bare die	Y
PCF85133U	80	160	240	320	-	-	-	1.8 to 5.5	2.5 to 6.5	82, 110 ^[2]	N	N	-40 to 85	I ² C	Bare die	N
PCA85133U	80	160	240	320	-	-	-	1.8 to 5.5	2.5 to 8	82, 110 ^[2]	N	N	-40 to 95	I ² C	Bare die	Y

Table 13. Selection of LCD segment drivers ...continued

Type name	Number of elements at MUX							V _{DD} (V)	V _{LCD} (V)	f _{fr} (Hz)	V _{LCD} (V) charge pump	V _{LCD} (V) temperature compensat.	T _{amb} (°C)	Interface	Package	AEC- Q100
	1:1	1:2	1:3	1:4	1:6	1:8	1:9									
PCA85233UG	80	160	240	320	-	-	-	1.8 to 5.5	2.5 to 8	150, 220 ^[2]	N	N	-40 to 105	I ² C	Bare die	Y
PCF85132U	160	320	480	640	-	-	-	1.8 to 5.5	1.8 to 8	60 to 90 ^[1]	N	N	-40 to 85	I ² C	Bare die	N
PCA8530DUG	102	204	-	408	-	-	-	2.5 to 5.5	4 to 12	45 to 300 ^[1]	Y	Y	-40 to 105	I ² C / SPI	Bare die	Y
PCA85132U	160	320	480	640	-	-	-	1.8 to 5.5	1.8 to 8	60 to 90 ^[1]	N	N	-40 to 95	I ² C	Bare die	Y
PCA85232U	160	320	480	640	-	-	-	1.8 to 5.5	1.8 to 8	117 to 176 ^[1]	N	N	-40 to 95	I ² C	Bare die	Y
PCF8538UG	102	204	-	408	612	816	918	2.5 to 5.5	4 to 12	45 to 300 ^[1]	Y	Y	-40 to 85	I ² C / SPI	Bare die	N
PCA8538UG	102	204	-	408	612	816	918	2.5 to 5.5	4 to 12	45 to 300 ^[1]	Y	Y	-40 to 105	I ² C / SPI	Bare die	Y

[1] Software programmable.

[2] Hardware selectable.

19. References

- [1] **AN10365** — Surface mount reflow soldering description
- [2] **AN10853** — ESD and EMC sensitivity of IC
- [3] **AN11267** — EMC and system level ESD design guidelines for LCD drivers
- [4] **IEC 61340-5** — Protection of electronic devices from electrostatic phenomena
- [5] **IPC/JEDEC J-STD-020D** — Moisture/Reflow Sensitivity Classification for Nonhermetic Solid State Surface Mount Devices
- [6] **JESD22-A114** — Electrostatic Discharge (ESD) Sensitivity Testing Human Body Model (HBM)
- [7] **JESD22-A115** — Electrostatic Discharge (ESD) Sensitivity Testing Machine Model (MM)
- [8] **JESD78** — IC Latch-Up Test
- [9] **JESD625-A** — Requirements for Handling Electrostatic-Discharge-Sensitive (ESDS) Devices
- [10] **SOT158-1_118** — VSO40; Reel pack; SMD, 13", packing information
- [11] **UM10204** — I²C-bus specification and user manual
- [12] **UM10569** — Store and transport requirements

20. Revision history

Table 14. Revision history

Document ID	Release date	Data sheet status	Change notice	Supersedes
PCF8577C v.5	20141010	Product data sheet	-	PCF8577C v.4
Modifications:	<ul style="list-style-type: none">• The format of this data sheet has been redesigned to comply with the new identity guidelines of NXP Semiconductors.• Legal texts have been adapted to the new company name where appropriate.• Removed obsolete product types.			
PCF8577C v.4	19980730	Product data sheet	-	PCF8577C v.3
PCF8577C v.3	19970328	Product data sheet	-	PCF8577C v.2
PCF8577C v.2	19950608	Product data sheet	-	PCF8577C v.1

21. Legal information

21.1 Data sheet status

Document status ^{[1][2]}	Product status ^[3]	Definition
Objective [short] data sheet	Development	This document contains data from the objective specification for product development.
Preliminary [short] data sheet	Qualification	This document contains data from the preliminary specification.
Product [short] data sheet	Production	This document contains the product specification.

[1] Please consult the most recently issued document before initiating or completing a design.

[2] The term 'short data sheet' is explained in section "Definitions".

[3] The product status of device(s) described in this document may have changed since this document was published and may differ in case of multiple devices. The latest product status information is available on the Internet at URL <http://www.nxp.com>.

21.2 Definitions

Draft — The document is a draft version only. The content is still under internal review and subject to formal approval, which may result in modifications or additions. NXP Semiconductors does not give any representations or warranties as to the accuracy or completeness of information included herein and shall have no liability for the consequences of use of such information.

Short data sheet — A short data sheet is an extract from a full data sheet with the same product type number(s) and title. A short data sheet is intended for quick reference only and should not be relied upon to contain detailed and full information. For detailed and full information see the relevant full data sheet, which is available on request via the local NXP Semiconductors sales office. In case of any inconsistency or conflict with the short data sheet, the full data sheet shall prevail.

Product specification — The information and data provided in a Product data sheet shall define the specification of the product as agreed between NXP Semiconductors and its customer, unless NXP Semiconductors and customer have explicitly agreed otherwise in writing. In no event however, shall an agreement be valid in which the NXP Semiconductors product is deemed to offer functions and qualities beyond those described in the Product data sheet.

21.3 Disclaimers

Limited warranty and liability — Information in this document is believed to be accurate and reliable. However, NXP Semiconductors does not give any representations or warranties, expressed or implied, as to the accuracy or completeness of such information and shall have no liability for the consequences of use of such information. NXP Semiconductors takes no responsibility for the content in this document if provided by an information source outside of NXP Semiconductors.

In no event shall NXP Semiconductors be liable for any indirect, incidental, punitive, special or consequential damages (including - without limitation - lost profits, lost savings, business interruption, costs related to the removal or replacement of any products or rework charges) whether or not such damages are based on tort (including negligence), warranty, breach of contract or any other legal theory.

Notwithstanding any damages that customer might incur for any reason whatsoever, NXP Semiconductors' aggregate and cumulative liability towards customer for the products described herein shall be limited in accordance with the *Terms and conditions of commercial sale* of NXP Semiconductors.

Right to make changes — NXP Semiconductors reserves the right to make changes to information published in this document, including without limitation specifications and product descriptions, at any time and without notice. This document supersedes and replaces all information supplied prior to the publication hereof.

Suitability for use — NXP Semiconductors products are not designed, authorized or warranted to be suitable for use in life support, life-critical or safety-critical systems or equipment, nor in applications where failure or malfunction of an NXP Semiconductors product can reasonably be expected to result in personal injury, death or severe property or environmental damage. NXP Semiconductors and its suppliers accept no liability for inclusion and/or use of NXP Semiconductors products in such equipment or applications and therefore such inclusion and/or use is at the customer's own risk.

Applications — Applications that are described herein for any of these products are for illustrative purposes only. NXP Semiconductors makes no representation or warranty that such applications will be suitable for the specified use without further testing or modification.

Customers are responsible for the design and operation of their applications and products using NXP Semiconductors products, and NXP Semiconductors accepts no liability for any assistance with applications or customer product design. It is customer's sole responsibility to determine whether the NXP Semiconductors product is suitable and fit for the customer's applications and products planned, as well as for the planned application and use of customer's third party customer(s). Customers should provide appropriate design and operating safeguards to minimize the risks associated with their applications and products.

NXP Semiconductors does not accept any liability related to any default, damage, costs or problem which is based on any weakness or default in the customer's applications or products, or the application or use by customer's third party customer(s). Customer is responsible for doing all necessary testing for the customer's applications and products using NXP Semiconductors products in order to avoid a default of the applications and the products or of the application or use by customer's third party customer(s). NXP does not accept any liability in this respect.

Limiting values — Stress above one or more limiting values (as defined in the Absolute Maximum Ratings System of IEC 60134) will cause permanent damage to the device. Limiting values are stress ratings only and (proper) operation of the device at these or any other conditions above those given in the Recommended operating conditions section (if present) or the Characteristics sections of this document is not warranted. Constant or repeated exposure to limiting values will permanently and irreversibly affect the quality and reliability of the device.

Terms and conditions of commercial sale — NXP Semiconductors products are sold subject to the general terms and conditions of commercial sale, as published at <http://www.nxp.com/profile/terms>, unless otherwise agreed in a valid written individual agreement. In case an individual agreement is concluded only the terms and conditions of the respective agreement shall apply. NXP Semiconductors hereby expressly objects to applying the customer's general terms and conditions with regard to the purchase of NXP Semiconductors products by customer.

No offer to sell or license — Nothing in this document may be interpreted or construed as an offer to sell products that is open for acceptance or the grant, conveyance or implication of any license under any copyrights, patents or other industrial or intellectual property rights.

Export control — This document as well as the item(s) described herein may be subject to export control regulations. Export might require a prior authorization from competent authorities.

Quick reference data — The Quick reference data is an extract of the product data given in the Limiting values and Characteristics sections of this document, and as such is not complete, exhaustive or legally binding.

Non-automotive qualified products — Unless this data sheet expressly states that this specific NXP Semiconductors product is automotive qualified, the product is not suitable for automotive use. It is neither qualified nor tested in accordance with automotive testing or application requirements. NXP Semiconductors accepts no liability for inclusion and/or use of non-automotive qualified products in automotive equipment or applications.

In the event that customer uses the product for design-in and use in automotive applications to automotive specifications and standards, customer (a) shall use the product without NXP Semiconductors' warranty of the product for such automotive applications, use and specifications, and (b)

whenever customer uses the product for automotive applications beyond NXP Semiconductors' specifications such use shall be solely at customer's own risk, and (c) customer fully indemnifies NXP Semiconductors for any liability, damages or failed product claims resulting from customer design and use of the product for automotive applications beyond NXP Semiconductors' standard warranty and NXP Semiconductors' product specifications.

Translations — A non-English (translated) version of a document is for reference only. The English version shall prevail in case of any discrepancy between the translated and English versions.

21.4 Trademarks

Notice: All referenced brands, product names, service names and trademarks are the property of their respective owners.

I²C-bus — logo is a trademark of NXP Semiconductors N.V.

22. Contact information

For more information, please visit: <http://www.nxp.com>

For sales office addresses, please send an email to: salesaddresses@nxp.com

23. Tables

Table 1.	Ordering information	1
Table 2.	Ordering options	2
Table 3.	Marking codes	2
Table 4.	Pin description	4
Table 5.	Segment byte-segment driver mapping in direct drive mode	8
Table 6.	Segment byte-segment driver mapping in duplex mode	8
Table 7.	I ² C slave address byte	10
Table 8.	Limiting values	12
Table 9.	Static characteristics	13
Table 10.	Dynamic characteristics	15
Table 11.	SnPb eutectic process (from J-STD-020D)	22
Table 12.	Lead-free process (from J-STD-020D)	22
Table 13.	Selection of LCD segment drivers	25
Table 14.	Revision history	28

24. Figures

Fig 1.	Block diagram of PCF8577C	2
Fig 2.	Pin configuration for PCF8577CT	3
Fig 3.	PCF8577C register organization	5
Fig 4.	Direct drive mode display output waveforms	6
Fig 5.	Duplex mode display output waveforms	7
Fig 6.	Bit transfer	9
Fig 7.	Definition of START and STOP conditions	9
Fig 8.	System configuration	10
Fig 9.	Acknowledgement of the I ² C-bus	10
Fig 10.	I ² C-bus protocol	11
Fig 11.	Driver timing waveforms	16
Fig 12.	I ² C-bus timing diagram; rise and fall times refer to V _{IL} and V _{IH}	16
Fig 13.	Direct display driver; expansion to 256 segments using eight PCF8577Cs	17
Fig 14.	Duplex display; expansion to 2 × 128 segments using four PCF8577Cs	18
Fig 15.	Use of PCF8577C as a 32-bit output expander in an I ² C-bus application	19
Fig 16.	Package outline SOT158-1 (VSO40) of PCF8577CT	20
Fig 17.	Temperature profiles for large and small components	23
Fig 18.	Footprint information for reflow soldering of SOT158-1 (VSO40) of PCF8577CT	24

25. Contents

1	General description	1	21	Legal information	29
2	Features and benefits	1	21.1	Data sheet status	29
3	Ordering information	1	21.2	Definitions	29
3.1	Ordering options	2	21.3	Disclaimers	29
4	Marking	2	21.4	Trademarks	30
5	Block diagram	2	22	Contact information	30
6	Pinning information	3	23	Tables	31
6.1	Pinning	3	24	Figures	32
6.2	Pin description	4	25	Contents	33
7	Functional description	4			
7.1	Hardware subaddress lines A0, A1, and A2 ...	4			
7.2	Oscillator A0/OSC	4			
7.3	User-accessible registers	5			
7.4	Auto-incremented loading	6			
7.5	Direct drive mode	6			
7.6	Duplex mode	6			
7.7	Display memory mapping	7			
7.8	Power-on reset	8			
8	I²C-bus interface	9			
8.1	Characteristics of the I ² C-Bus	9			
8.1.1	Bit transfer	9			
8.1.2	START and STOP conditions	9			
8.1.3	System configuration	9			
8.1.4	Acknowledge	10			
8.2	Slave address	10			
8.3	I ² C-bus protocol	11			
9	Safety notes	11			
10	Limiting values	12			
11	Static characteristics	13			
12	Dynamic characteristics	15			
13	Application information	17			
14	Package outline	20			
15	Packing information	21			
15.1	Tape and reel information	21			
16	Soldering of SMD packages	21			
16.1	Introduction to soldering	21			
16.2	Wave and reflow soldering	21			
16.3	Wave soldering	21			
16.4	Reflow soldering	22			
17	Footprint information	23			
18	Appendix	25			
18.1	LCD segment driver selection	25			
19	References	27			
20	Revision history	28			

Please be aware that important notices concerning this document and the product(s) described herein, have been included in section 'Legal information'.

© NXP Semiconductors N.V. 2014.

All rights reserved.

For more information, please visit: <http://www.nxp.com>

For sales office addresses, please send an email to: salesaddresses@nxp.com

Date of release: 10 October 2014

Document identifier: PCF8577C

Данный компонент на территории Российской Федерации

Вы можете приобрести в компании MosChip.

Для оперативного оформления запроса Вам необходимо перейти по данной ссылке:

<http://moschip.ru/get-element>

Вы можете разместить у нас заказ для любого Вашего проекта, будь то серийное производство или разработка единичного прибора.

В нашем ассортименте представлены ведущие мировые производители активных и пассивных электронных компонентов.

Нашей специализацией является поставка электронной компонентной базы двойного назначения, продукции таких производителей как XILINX, Intel (ex.ALTERA), Vicor, Microchip, Texas Instruments, Analog Devices, Mini-Circuits, Amphenol, Glenair.

Сотрудничество с глобальными дистрибьюторами электронных компонентов, предоставляет возможность заказывать и получать с международных складов практически любой перечень компонентов в оптимальные для Вас сроки.

На всех этапах разработки и производства наши партнеры могут получить квалифицированную поддержку опытных инженеров.

Система менеджмента качества компании отвечает требованиям в соответствии с ГОСТ Р ИСО 9001, ГОСТ РВ 0015-002 и ЭС РД 009

Офис по работе с юридическими лицами:

105318, г.Москва, ул.Щербаковская д.3, офис 1107, 1118, ДЦ «Щербаковский»

Телефон: +7 495 668-12-70 (многоканальный)

Факс: +7 495 668-12-70 (доб.304)

E-mail: info@moschip.ru

Skype отдела продаж:

moschip.ru

moschip.ru_4

moschip.ru_6

moschip.ru_9