

MINI MCR-SL-UI-I-LP-NC

2-way isolation amplifier



Data sheet
105263_en_02

© PHOENIX CONTACT 2013-12-13

1 Description

The configurable 2-way isolation amplifiers are used to electrically isolate, convert and filter standard signals.

You can configure analog voltage or current signal areas on the input side using the DIP switch.

The isolation amplifier supplied by the output loop enables connection of an active analog input module of a controller. Supply takes place via the active 4...20 mA loop of the controller.

Features

- Configurable 2-way isolation amplifier
- Approval for Ex-zone 2 (nA)
- Screw or spring-cage connection can be provided

**NOTE: Correct usage in potentially explosive areas**

The module is a category 3 item of electrical equipment. It is absolutely vital to follow the instructions provided here during installation and observe the information in the "Safety regulations and installation notes".



Make sure you always use the latest documentation.
It can be downloaded from the product at phoenixcontact.net/products.



This data sheet is valid for all products listed on the following page:

2	Table of contents	
1	Description	1
2	Table of contents	2
3	Ordering data	3
4	Technical data	4
5	Safety regulations and installation notes.....	7
	5.1 Installation notes	7
	5.2 Installation in the Ex area (zone 2).....	7
6	Installation	8
	6.1 Connection notes	8
	6.2 Structure	8
	6.3 Block diagram.....	8
	6.4 Power supply.....	8
	6.5 Assembly.....	9
	6.6 Connection of the cables	9
7	Configuration	10
	7.1 Configuration table.....	11
8	Adjustment	12
	8.1 Easy adjustment.....	12
	8.2 Output with adjustment point calculation.....	12

3 Ordering data

Description	Type	Order No.	Pcs. / Pkt.
2-way loop-powered isolating amplifier (supplied on the output side), can be configured via DIP switches, with screw connection technology and standard configuration.	MINI MCR-SL-UI-I-LP-NC	2902829	1
2-way loop-powered isolating amplifier (supplied on the output side), can be configured via DIP switches, with spring-cage connection technology and standard configuration.	MINI MCR-SL-UI-I-LP-SP-NC	2902830	1
Accessories	Type	Order No.	Pcs. / Pkt.
Eight MINI analog signal converters with screw connection method can be connected to a control system using a system adapter and system cabling with a minimum of wiring and very low error risk.	MINI MCR-SL-V8-FLK 16-A	2811268	1
Fold up transparent cover for MINI MCR modules with additional labeling option using insert strips and flat Zack marker strip 6.2 mm	MINI MCR DKL	2308111	10
Label for extended marking of MINI MCR modules in connection with the MINI MCR-DKL	MINI MCR-DKL-LABEL	2810272	10

4 Technical data

Input

Voltage input signal	0 mV ... 1000 mV 0 mV ... 750 mV 0 mV ... 500 mV 0 mV ... 300 mV 0 mV ... 250 mV 0 mV ... 200 mV 0 mV ... 150 mV 0 mV ... 125 mV 0 mV ... 120 mV 0 mV ... 100 mV 0 mV ... 75 mV 0 mV ... 60 mV 0 mV ... 50 mV 0 V ... 10 V 0 V ... 7.5 V 0 V ... 5 V 0 V ... 3 V 0 V ... 2.5 V 0 V ... 2 V 0 V ... 1.5 V 0 V ... 1.25 V 0 V ... 1.2 V 0 V ... 30 V 0 V ... 25 V 0 V ... 20 V 0 V ... 12.5 V 0 V ... 12 V 0 V ... 15 V -1000 mV ... 1000 mV -750 mV ... 750 mV -500 mV ... 500 mV -300 mV ... 300 mV -250 mV ... 250 mV -200 mV ... 200 mV -125 mV ... 125 mV -120 mV ... 120 mV -150 mV ... 150 mV -100 mV ... 100 mV -75 mV ... 75 mV -60 mV ... 60 mV -50 mV ... 50 mV -10 V ... 10 V -7.5 V ... 7.5 V -5 V ... 5 V -3 V ... 3 V -2.5 V ... 2.5 V -2 V ... 2 V -1.25 V ... 1.25 V -1.2 V ... 1.2 V -1.5 V ... 1.5 V -30 V ... 30 V -25 V ... 25 V -20 V ... 20 V -12.5 V ... 12.5 V -12 V ... 12 V -15 V ... 15 V 1 V ... 5 V
Max. voltage input signal	< 40 V

Input [...]

Current input signal	0 mA ... 40 mA 0 mA ... 30 mA 0 mA ... 20 mA 0 mA ... 12 mA 0 mA ... 10 mA 0 mA ... 8 mA 0 mA ... 7.5 mA 0 mA ... 5 mA 0 mA ... 6 mA 0 mA ... 4 mA 0 mA ... 3 mA 0 mA ... 2.5 mA 0 mA ... 2 mA 4 mA ... 20 mA 2 mA ... 10 mA 1 mA ... 5 mA
Max. current input signal	< 50 mA (Dielectric strength up to 30 V)
Input resistance of voltage input	approx. 100 kΩ (At ≤ 1 V, otherwise approximately 1 MΩ)
Input resistance current input	≤ 50 Ω

Output

Current output signal	4 mA ... 20 mA
Max. current output signal	35 mA (output limit)
Configurable/programmable	Yes, preconfigured
Ripple	< 20 mV _{PP} (at 500 Ω)
Load/output load current output	((U _B - 8 V) / 22 mA)

Supply

Supply voltage range	8 V DC ... 30 V DC
Power consumption	28 mW (without signal)

General data

Limit frequency (3 dB)	approx. 30 Hz
Maximum transmission error	< 0.1 % (of final value) < 0.2 % (Without adjustment)
Temperature coefficient, typical	0.005 %/K
Maximum temperature coefficient	0.01 %/K
Alignment zero	± 2 %
Alignment span	± 2 %
Step response (10-90%)	approx. 16 ms
Electrical isolation	Basic insulation according to EN 61010
Surge voltage category	II
Mounting position	any
Degree of protection	IP20
Pollution degree	2
Rated insulation voltage	50 V AC/DC
Dimensions W / H / D	6.2 mm / 93.1 mm / 102.5 mm
Type of housing	PBT green

Connection data

Screw connection

Spring-cage conn.

Conductor cross section, solid	0.2 mm ² ... 2.5 mm ²	0.2 mm ² ... 2.5 mm ²
Conductor cross section, stranded	0.2 mm ² ... 2.5 mm ²	0.2 mm ² ... 2.5 mm ²
Stripping length	12 mm	8 mm

Ambient conditions

Ambient temperature (operation)	-25 °C ... 70 °C
Ambient temperature (storage/transport)	-40 °C ... 85 °C

Conformance with EMC Directive 2004/108/EC

Noise immunity according to EN 61000-6-2
 When being exposed to interference, there may be minimal deviations.
 Noise emission according to EN 61000-6-4

Conformance / approvals

Conformance	CE-compliant
ATEX	Ex II 3 G Ex nA IIC T4 Gc X
UL, USA / Canada	UL 508 Listed
UL, USA / Canada	Class I, Div. 2, Groups A, B, C, D T5
UL, USA / Canada	Class I, Zone 2, Group IIC

5 Safety regulations and installation notes

5.1 Installation notes

- The category 3 device is suitable for installation in the zone 2 potentially explosive area. It fulfills the requirements of EN 60079-0:2009 and EN 60079-15:2010.
- Installation, operation, and maintenance may only be carried out by qualified electricians. Follow the installation instructions described. When installing and operating the device, the applicable regulations and safety directives (including national safety directives), as well as general technical regulations, must be observed. The technical data is provided in this package slip and on the certificates (conformity assessment, additional approvals where applicable).
- It is not permissible to open or modify the device. Do not repair the device yourself but replace it with an equivalent device. Repairs may only be carried out by the manufacturer. The manufacturer is not liable for damage resulting from violation.
- The IP20 degree of protection (IEC 60529/EN 60529) of the device is intended for use in a clean and dry environment. Do not subject the device to any load that exceeds the described limits.
- The device is not designed for use in atmospheres with a danger of dust explosions.

5.2 Installation in the Ex area (zone 2)

- Observe the specified conditions for use in potentially explosive areas.
- The device must be installed in a housing (control or distributor box) which meets the requirements of EN 60079-15 and provides at least IP54 (EN 60529) degree of protection.
- During installation and when connecting the supply and signal circuits, observe the requirements of EN 60079-14. Devices may only be connected to circuits in zone 2 if they are suitable for operation in Ex zone 2 and for the prevailing conditions at the place of use.
- In potentially explosive areas, terminals may only be snapped onto or off the DIN rail connector and wires may only be connected or disconnected when the power is switched off.
- The device must be stopped and immediately removed from the Ex area if it is damaged, has been subjected to an impermissible load, has been stored incorrectly, or if it malfunctions.
- You can download the latest documents for these devices from phoenixcontact.net/products.

6 Installation

6.1 Connection notes



NOTE: electrostatic discharge!

The device contains components that can be damaged or destroyed by electrostatic discharge. When handling the device, observe the necessary safety precautions against electrostatic discharge (ESD) according to EN 61340-5-1 and EN 61340-5-1.

6.2 Structure

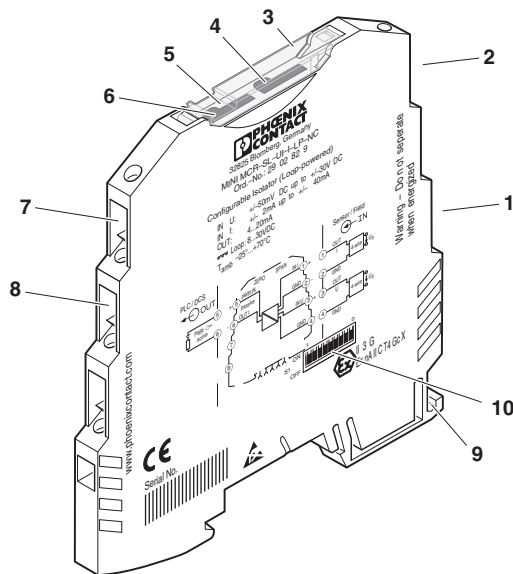

Figure 1 Structure

1. Input: voltage signals
2. Input: current signals
3. Cover
4. ZERO potentiometer for adjustment
5. Groove for ZBF 6 zack marker strip
6. SPAN potentiometer for adjustment
7. Input supply voltage
8. Output 4 ... 20 mA
9. Universal snap-on foot for EN DIN rails
10. DIP switch S1

6.3 Block diagram

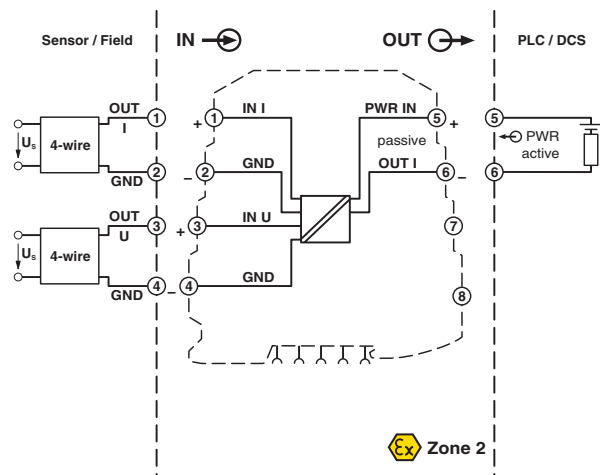

Figure 2 Block diagram

6.4 Power supply

An ME 6,2 TBUS-2 DIN rail connector (Order No.: 2869728) is used to supply active devices. A DIN rail connector is not necessary for operation of this loop-powered device.

This device can be snapped onto a DIN rail connector – an electrically conductive connection is not established. This means that you do not need to disconnect an existing DIN rail connector element connection.

6.5 Assembly

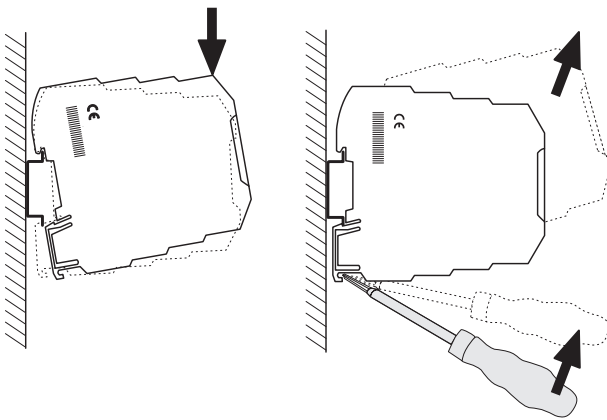

Figure 3 Mounting and removing

- Mount the module on a 35 mm DIN rail according to EN 60715.

6.6 Connection of the cables

The MINI MCR-SL-UI-I-LP... is available in two connection versions:

- Screw terminal blocks (MINI MCR-SL-UI-I-LP-NC)
- Spring-cage terminal blocks (MINI MCR-SL-UI-I-LP-SP-NC)

Screw connection:

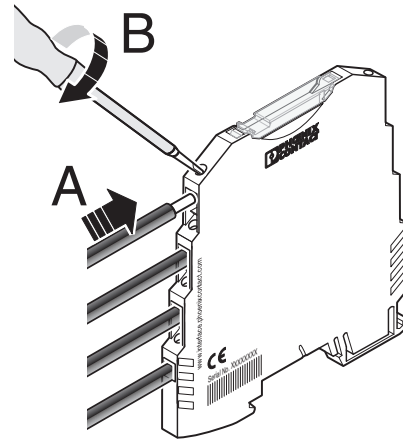

Figure 4 Screw connection

- Insert the wire into the corresponding connection terminal block.
- Use a screwdriver to tighten the screw in the opening above the connection terminal block.

Spring-cage connection:

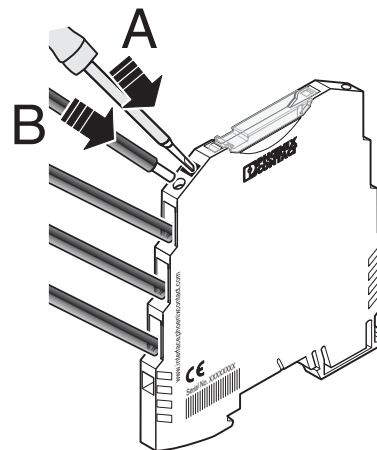

Figure 5 Spring-cage connection

- Insert a screwdriver into the opening above the connection terminal block.
- Insert the wire into the corresponding connection terminal block.

7 Configuration

DIP switch S1 is used to specify the combination of input and output standard signal ranges (see "Configuration table").

Standard Configuration

If it is an "NC version", the device has the standard configuration:

- Input 2...10 V
- Output 4...20 mA

(All DIP switches are set to the "off" position, transmission error < 0.1%.)

7.1 Configuration table

DIP switch S1 is used to specify the combination of input and output standard signal ranges (see "Configuration table").

IN	• ≙ ON			DIP S1										Terminal		
	Unipolar	Bipolar	Live Zero	1	2	3	4	5	6	7	8	9	0			
0 ... 40 mA															(1)	(2)
0 ... 30 mA													•		(1)	(2)
0 ... 20 mA			4 ... 20 mA											•	(1)	(2)
0 ... 12 mA													•	•	(1)	(2)
0 ... 10 mA			2 ... 10 mA										•	•	(1)	(2)
0 ... 8 mA													•		(1)	(2)
0 ... 7.5 mA													•	•	(1)	(2)
0 ... 5 mA			1 ... 5 mA										•	•	(1)	(2)
0 ... 6 mA													•		(1)	(2)
0 ... 4 mA													•	•	(1)	(2)
0 ... 3 mA													•	•	(1)	(2)
0 ... 2.5 mA													•	•	(1)	(2)
0 ... 2 mA													•	•	(1)	(2)
0 ... 1000 mV	±1000 mV			•											(3)	(4)
0 ... 750 mV	±750 mV			•										•	(3)	(4)
0 ... 500 mV	±500 mV			•										•	(3)	(4)
0 ... 300 mV	±300 mV			•										•	(3)	(4)
0 ... 250 mV	±250 mV			•										•	(3)	(4)
0 ... 200 mV	±200 mV			•										•	(3)	(4)
0 ... 125 mV	±125 mV			•										•	(3)	(4)
0 ... 120 mV	±120 mV			•										•	(3)	(4)
0 ... 150 mV	±150 mV			•										•	(3)	(4)
0 ... 100 mV	±100 mV			•										•	(3)	(4)
0 ... 75 mV	±75 mV			•										•	(3)	(4)
0 ... 60 mV	±60 mV			•										•	(3)	(4)
0 ... 50 mV	±50 mV			•										•	(3)	(4)
0 ... 10 V	±10 V	2 ... 10 V													(3)	(4)
0 ... 7.5 V	±7.5 V														(3)	(4)
0 ... 5 V	±5 V	1 ... 5 V													(3)	(4)
0 ... 3 V	±3 V														(3)	(4)
0 ... 2.5 V	±2.5 V														(3)	(4)
0 ... 2 V	±2 V														(3)	(4)
0 ... 1.25 V	±1.25 V														(3)	(4)
0 ... 1.2 V	±1.2 V														(3)	(4)
0 ... 1.5 V	±1.5 V														(3)	(4)
0 ... 30 V	±30 V														(3)	(4)
0 ... 25 V	±25 V														(3)	(4)
0 ... 20 V	±20 V														(3)	(4)
0 ... 12.5 V	±12.5 V														(3)	(4)
0 ... 12 V	±12 V														(3)	(4)
0 ... 15 V	±15 V														(3)	(4)
Signal conversion	IN bipolar /	OUT Live zero (4 ... 20 mA)														•
	IN unipolar /	OUT Live zero (4 ... 20 mA)														•
	IN Live zero /	OUT Live zero (4 ... 20 mA)														



Additional signal combinations that are not listed in the table are available on request.

8 Adjustment

Two potentiometers are located under the cover. These are used for fine adjustment of the analog signals after the configuration of the DIP switches has been changed.

The transmission error without adjustment is < 0.2 %. The transmission error without adjustment is < 0.1%.



You require measuring equipment with the corresponding accuracy for exact adjustment!

8.1 Easy adjustment

Adjustment of the module via two potentiometers.

- ZERO potentiometer: zero point adjustment
- SPAN potentiometer: final value adjustment

8.2 Output with adjustment point calculation

- Specify the final value of the input signal with a calibration source initial and final value.
- Note the respective measured output value.

Output signal: 4...20 mA

Specification (input)	Measured value (output)
Initial value	MV 1 [mA]
Final value	MV 2 [mA]

Calculate the FS adjustment point A

- Specify the initial value of the input signal with a calibration source.
- SPAN potentiometer: FS adjustment point $A \pm 1 \mu\text{A}$
- ZERO potentiometer: $20 \text{ mA} \pm 1 \mu\text{A}$

$$A = \frac{\text{MV } 2 \times 16 \text{ mA}}{\text{MV } 2 - \text{MV } 1}$$

Данный компонент на территории Российской Федерации

Вы можете приобрести в компании MosChip.

Для оперативного оформления запроса Вам необходимо перейти по данной ссылке:

<http://moschip.ru/get-element>

Вы можете разместить у нас заказ для любого Вашего проекта, будь то серийное производство или разработка единичного прибора.

В нашем ассортименте представлены ведущие мировые производители активных и пассивных электронных компонентов.

Нашей специализацией является поставка электронной компонентной базы двойного назначения, продукции таких производителей как XILINX, Intel (ex.ALTERA), Vicor, Microchip, Texas Instruments, Analog Devices, Mini-Circuits, Amphenol, Glenair.

Сотрудничество с глобальными дистрибьюторами электронных компонентов, предоставляет возможность заказывать и получать с международных складов практически любой перечень компонентов в оптимальные для Вас сроки.

На всех этапах разработки и производства наши партнеры могут получить квалифицированную поддержку опытных инженеров.

Система менеджмента качества компании отвечает требованиям в соответствии с ГОСТ Р ИСО 9001, ГОСТ РВ 0015-002 и ЭС РД 009

Офис по работе с юридическими лицами:

105318, г.Москва, ул.Щербаковская д.3, офис 1107, 1118, ДЦ «Щербаковский»

Телефон: +7 495 668-12-70 (многоканальный)

Факс: +7 495 668-12-70 (доб.304)

E-mail: info@moschip.ru

Skype отдела продаж:

moschip.ru

moschip.ru_4

moschip.ru_6

moschip.ru_9