

To Our Customers

CEL continues to offer industry leading semiconductor products from Japan. We are pleased to add new communication products from THine Electronics to our product portfolio.



THCV218

V-by-One® HS High-speed video data receiver

General Description

THCV218 is designed to support video data transmission between the host and display. One high-speed lane can carry up to 32bit data and 3 bits of synchronizing signals at a pixel clock frequency from 20MHz to 85MHz. This chip, which has two high-speed data lanes, can receive video data up to 1080p/10b/60Hz. The maximum serial data rate is 3.4Gbps/lane.

Width	Link	CMOS IO Frequency
24bit and 32bit	Si/So	20MHz to 85MHz
	Di/Do	
	Di/So	40MHz to 170MHz

Features

- Color depth selectable: 24(8*3)/32(10*3)bit
- Single-in/Single-out, Dual-in/Single-out, and Dual-in/Dual-out selectable.
- AC coupling for high-speed lines
- CORE 1.8v, CMOS IO 3.3v
- Package: TFBGA105
- Wide frequency range
- CDR requires no external frequency reference
- 3.3V logic compatible output interface.

Si/So: Single-in/Single-out,
Di/So: Dual-in/Single-out, Di/Do: Dual-in/Single-out

Block Diagram

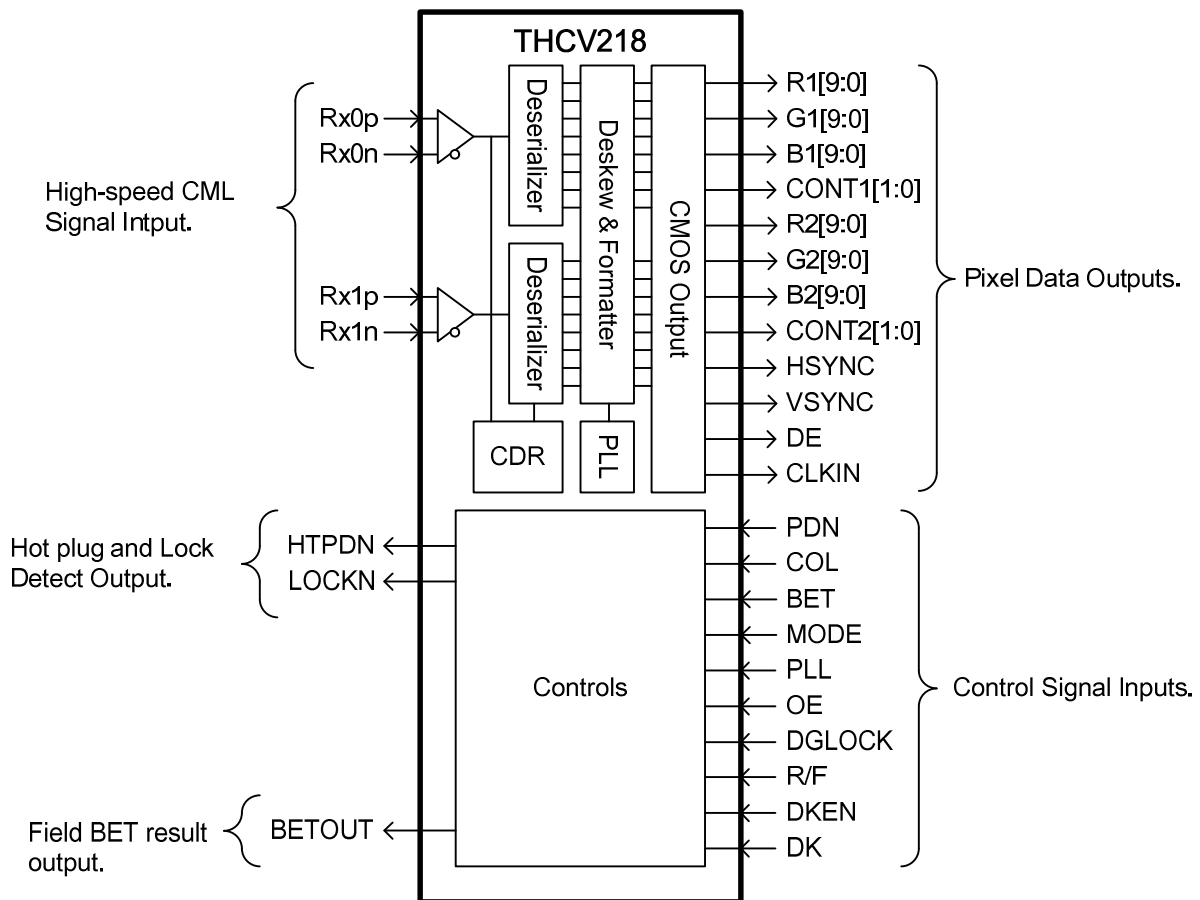

Example System Diagram

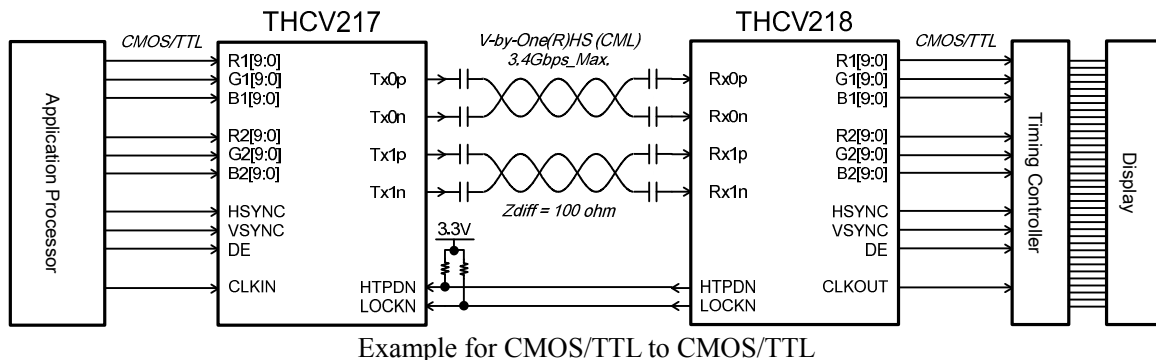

Example for CMOS/TTL to CMOS/TTL

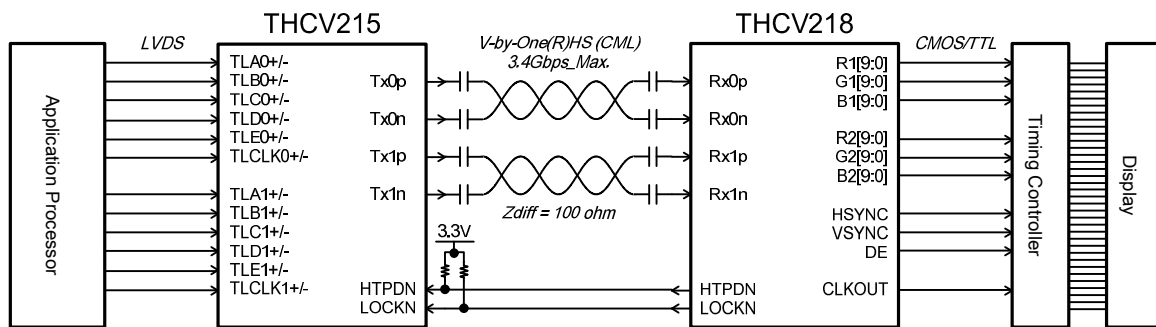

Example for LVDS to CMOS/TTL

Notices and Requests

1. The product specifications described in this material are subject to change without prior notice.
2. The circuit diagrams described in this material are examples of the application which may not always apply to the customer's design. We are not responsible for possible errors and omissions in this material. Please note if errors or omissions should be found in this material, we may not be able to correct them immediately.
3. This material contains our copy right, know-how or other proprietary. Copying or disclosing to third parties the contents of this material without our prior permission is prohibited.
4. Note that if infringement of any third party's industrial ownership should occur by using this product, we will be exempted from the responsibility unless it directly relates to the production process or functions of the product.
5. This product is presumed to be used for general electric equipment, not for the applications which require very high reliability (including medical equipment directly concerning people's life, aerospace equipment, or nuclear control equipment). Also, when using this product for the equipment concerned with the control and safety of the transportation means, the traffic signal equipment, or various Types of safety equipment, please do it after applying appropriate measures to the product.
6. Despite our utmost efforts to improve the quality and reliability of the product, faults will occur with a certain small probability, which is inevitable to a semi-conductor product. Therefore, you are encouraged to have sufficiently redundant or error preventive design applied to the use of the product so as not to have our product cause any social or public damage.
7. Please note that this product is not designed to be radiation-proof.
8. Customers are asked, if required, to judge by themselves if this product falls under the category of strategic goods under the Foreign Exchange and Foreign Trade Control Law.

THine Electronics, Inc.
 sales@thine.co.jp

Данный компонент на территории Российской Федерации

Вы можете приобрести в компании MosChip.

Для оперативного оформления запроса Вам необходимо перейти по данной ссылке:

<http://moschip.ru/get-element>

Вы можете разместить у нас заказ для любого Вашего проекта, будь то серийное производство или разработка единичного прибора.

В нашем ассортименте представлены ведущие мировые производители активных и пассивных электронных компонентов.

Нашей специализацией является поставка электронной компонентной базы двойного назначения, продукции таких производителей как XILINX, Intel (ex.ALTERA), Vicor, Microchip, Texas Instruments, Analog Devices, Mini-Circuits, Amphenol, Glenair.

Сотрудничество с глобальными дистрибьюторами электронных компонентов, предоставляет возможность заказывать и получать с международных складов практически любой перечень компонентов в оптимальные для Вас сроки.

На всех этапах разработки и производства наши партнеры могут получить квалифицированную поддержку опытных инженеров.

Система менеджмента качества компании отвечает требованиям в соответствии с ГОСТ Р ИСО 9001, ГОСТ РВ 0015-002 и ЭС РД 009

Офис по работе с юридическими лицами:

105318, г.Москва, ул.Щербаковская д.3, офис 1107, 1118, ДЦ «Щербаковский»

Телефон: +7 495 668-12-70 (многоканальный)

Факс: +7 495 668-12-70 (доб.304)

E-mail: info@moschip.ru

Skype отдела продаж:

moschip.ru

moschip.ru_4

moschip.ru_6

moschip.ru_9