

# TCS3772

## Color Light-to-Digital Converter with Proximity Sensing

### General Description

The TCS3772 device family provides red, green, blue, and clear (RGBC) light sensing and, when coupled with an external IR LED, proximity detection. These devices detect light intensity under a variety of lighting conditions and through a variety of attenuation materials, including dark glass. The proximity detection feature allows a large dynamic range of operation for accurate short distance detection, such as in a cell phone, for detecting when the user positions the phone close to their ear. An internal state machine provides the ability to put the device into a low power state in between proximity and RGBC measurements providing very low average power consumption.

The color sensing feature is useful in applications such as LED RGB backlight control, solid state lighting, reflected LED color sampler, or fluorescent light color temperature detection. With the addition of an IR blocking filter, the device is an excellent ambient light sensor, color temperature monitor, and general purpose color sensor.

*Ordering Information and Content Guide appear at end of datasheet.*

### Key Benefits & Features

The benefits and features of this device are listed below:

**Figure 1:**  
Added Value of Using TCS3772

Benefits	Features
<ul style="list-style-type: none"> <li>• Single Device Reduces Board Space</li> </ul>	<ul style="list-style-type: none"> <li>• Integrated RGB and Clear Color Sensing and Proximity Detection</li> </ul>
<ul style="list-style-type: none"> <li>• Enables Flexible Operation for Wide Range of Applications</li> </ul>	<ul style="list-style-type: none"> <li>• Programmable Color Sensing and Proximity Detection</li> </ul>
<ul style="list-style-type: none"> <li>• Enables Accurate Color and Ambient Light Sensing Under Varying Lighting Conditions</li> </ul>	<ul style="list-style-type: none"> <li>• Integrated IR Blocking Filter</li> </ul>
<ul style="list-style-type: none"> <li>• Enables Operation within Wide Range of Lighting Conditions</li> </ul>	<ul style="list-style-type: none"> <li>• 3.8M:1 Dynamic Range</li> </ul>

- Color Light Sensing with IR-Blocking Filter
  - Programmable Analog Gain and Integration Time
  - 3 800 000:1 Dynamic Range
  - Very High Sensitivity – Ideally Suited for Operation Behind Dark Glass
- Proximity Detection
  - Ambient Light Rejection
  - Programmable Integration Time
  - Current Sink Driver for External IR LED
- Maskable Light and Proximity Interrupt
  - Programmable Upper and Lower Thresholds with Persistence Filter
- Power Management
  - Low Power – 2.5- $\mu$ A Sleep State
  - 65- $\mu$ A Wait State with Programmable Wait State Time from 2.4 ms to > 7 Seconds
- I<sup>2</sup>C Fast Mode Compatible Interface
  - Data Rates up to 400 kbit/s
  - Input Voltage Levels Compatible with V<sub>DD</sub> or 1.8 V Bus
- Register Set and Pin Compatible with the TCS3x71 Series
- Small 2 mm × 2.4 mm Dual Flat No-Lead (FN) Package

## Applications

The applications of TCS3772 include:

- RGB LED Backlight Control
- Ambient Light Color Temperature Sensing
- Cell Phone Touch Screen Disable
- Mechanical Switch Replacement
- Industrial Process Control
- Medical Diagnostics

## End Products and Market Segments

- HDTVs, Mobile Handsets, Tablets, and Portable Media Payers
- Medical and Commercial Instrumentation
- Toys
- Solid State and General Lighting

### Block Diagram

The functional blocks of this device are shown below:

**Figure 2:**  
Functional Block Diagram of TCS3772

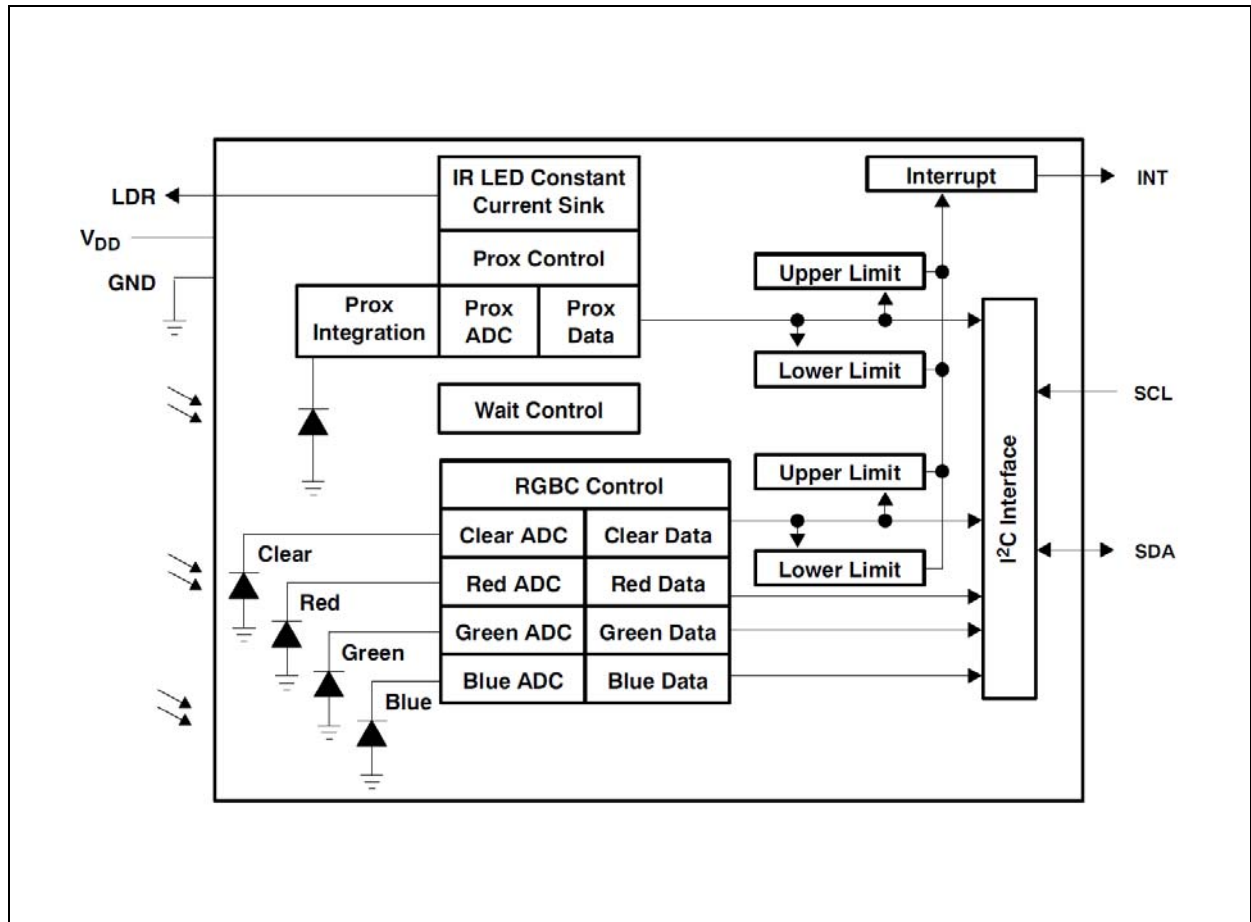

## Pin Assignment

The TCS3772 pin assignments are described below.

**Figure 3:**  
Pin Diagram

**Package FN Dual Flat No-Lead (Top View):**

Package drawing is not to scale.

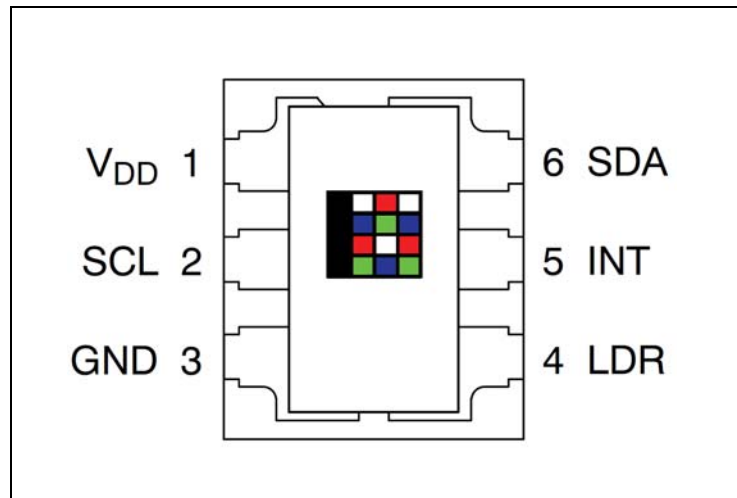

**Figure 4:**  
Pin Description

Pin Number	Pin Name	Pin Type	Description
1	V <sub>DD</sub>		Supply voltage
2	SCL	Input	I <sup>2</sup> C serial clock input terminal – clock signal for I <sup>2</sup> C serial data.
3	GND		Power supply ground. All voltages are referenced to GND.
4	LDR	Output	LED driver for proximity emitter – open drain.
5	INT	Output	Interrupt – open drain (active low).
6	SDA	Input/Output	I <sup>2</sup> C serial data I/O terminal — serial data I/O for I <sup>2</sup> C.

## Absolute Maximum Ratings

Stresses beyond those listed under [Absolute Maximum Ratings](#) may cause permanent damage to the device. These are stress ratings only. Functional operation of the device at these or any other conditions beyond those indicated under [Recommended Operating Conditions](#) is not implied. Exposure to absolute maximum rated conditions for extended periods may affect device reliability.

**Figure 5:**  
Absolute Maximum Ratings over Operating Free-Air Temperature Range (unless otherwise noted)

Parameter	Min	Max	Units	Comments
Supply voltage, $V_{DD}$		3.8	V	All voltages are with respect to GND
Input terminal voltage	-0.5	3.8	V	
Output terminal voltage (except LDR)	-0.5	3.8	V	
Output terminal voltage (LDR)	-0.5	3.8	V	
Output terminal current (except LDR)	-1	20	mA	
Storage temperature range, $T_{STRG}$	-40	85	°C	
ESD tolerance, human body model	±2000		V	

## Electrical Characteristics

All limits are guaranteed. The parameters with min and max values are guaranteed with production tests or SQC (Statistical Quality Control) methods.

**Figure 6:**  
Recommended Operating Conditions

Symbol	Parameter	Conditions	Min	Typ	Max	Units
$V_{DD}$	Supply voltage	TCS37725 ( $I^2C$ $V_{BUS} = V_{DD}$ )	2.7	3	3.6	V
		TCS37727 ( $I^2C$ $V_{BUS} = 1.8$ V)	2.7	3	3.3	
$T_A$	Operating free-air temperature		-30		70	°C

**Figure 7:**  
Operating Characteristics,  $V_{DD} = 3$  V,  $T_A = 25^\circ\text{C}$  (unless otherwise noted)

Symbol	Parameter	Conditions	Min	Typ	Max	Units
$I_{DD}$	Supply current	Active – LDR pulses off		235	330	$\mu\text{A}$
		Wait state		65		
		Sleep state - no $I^2C$ activity		2.5	10	
$V_{OL}$	INT SDA output low voltage	3 mA sink current	0		0.4	V
		6 mA sink current	0		0.6	
$I_{LEAK}$	Leakage current, SDA, SCL, INT pins		-5		5	$\mu\text{A}$
	Leakage current, LDR pin		-5		5	
$V_{IH}$	SCL SDA input high voltage	TCS37725	$0.7 V_{DD}$			V
		TCS37727	1.25			
$V_{IL}$	SCL SDA input low voltage	TCS37725			$0.3 V_{DD}$	V
		TCS37727			0.54	

**Figure 8:**  
Optical Characteristics,  $V_{DD} = 3\text{ V}$ ,  $T_A = 25^\circ\text{C}$ ,  $AGAIN = 16\times$ ,  $ATIME = 0xF6$  (unless otherwise noted)<sup>(1)</sup>

Parameter	Test Conditions	Red Channel		Green Channel		Blue Channel		Clear Channel			Unit
		Min	Max	Min	Max	Min	Max	Min	Typ	Max	
R <sub>e</sub> Irradiance responsivity	$\lambda_D = 465\text{ nm}$ <sup>(2)</sup>	0%	15%	10%	42%	65%	88%	11.0	13.8	16.6	counts / $\mu\text{W}$ / $\text{cm}^2$
	$\lambda_D = 525\text{ nm}$ <sup>(3)</sup>	4%	25%	60%	85%	10%	45%	13.2	16.6	20.0	
	$\lambda_D = 615\text{ nm}$ <sup>(4)</sup>	80%	110%	0%	14%	5%	24%	15.6	19.5	23.4	

**Note(s):**

- The percentage shown represents the ratio of the respective red, green, or blue channel value to the clear channel value.
- The 465 nm input irradiance is supplied by an InGaN light-emitting diode with the following characteristics: dominant wavelength  $\lambda_D = 465\text{ nm}$ , spectral halfwidth  $\Delta\lambda_{1/2} = 22\text{ nm}$ .
- The 525 nm input irradiance is supplied by an InGaN light-emitting diode with the following characteristics: dominant wavelength  $\lambda_D = 525\text{ nm}$ , spectral halfwidth  $\Delta\lambda_{1/2} = 35\text{ nm}$ .
- The 615 nm input irradiance is supplied by a AlInGaP light-emitting diode with the following characteristics: dominant wavelength  $\lambda_D = 615\text{ nm}$ , spectral halfwidth  $\Delta\lambda_{1/2} = 15\text{ nm}$ .

**Figure 9:**  
RGBC Characteristics,  $V_{DD} = 3\text{ V}$ ,  $T_A = 25^\circ\text{C}$ ,  $AGAIN = 16\times$ ,  $AEN = 1$  (unless otherwise noted)

Parameter	Conditions	Min	Typ	Max	Units
Dark ADC count value	$E_e = 0$ , $AGAIN = 60\times$ , $ATIME = 0xD6$ (100 ms)	0	1	5	counts
ADC integration time step size	$ATIME = 0xFF$	2.27	2.4	2.56	ms
ADC number of integration steps <sup>(1)</sup>		1		256	steps
ADC counts per step <sup>(1)</sup>		0		1024	counts
ADC count value <sup>(1)</sup>	$ATIME = 0xC0$ (153.6 ms)	0		65535	counts
Gain scaling, relative to 1× gain setting	4×	3.8	4	4.2	×
	16×	15	16	16.8	
	60×	58	60	63	

**Note(s):**

- Parameter ensured by design and is not tested.

**Figure 10:**  
 Proximity Characteristics,  $V_{DD} = 3\text{ V}$ ,  $T_A = 25^\circ\text{C}$ ,  $PEN = 1$  (unless otherwise noted)

Parameter	Conditions	Min	Typ	Max	Units	
$I_{DD}$ Supply current	LDR pulse on		3		mA	
ADC conversion time step size	PTIME = 0xFF	2.27	2.4	2.56	ms	
ADC number of integration steps <sup>(1)</sup>		1		256	steps	
ADC counts per step <sup>(1)</sup>	PTIME = 0xFF	0		1023	counts	
ADC count value	$\lambda_p = 850\text{ nm}$ , $E_e = 770.1\ \mu\text{W}/\text{cm}^2$ , PTIME = 0xFB, PPULSE = 1 <sup>(3)</sup>	1350		1900	counts	
ADC output responsivity	$\lambda_p = 850\text{ nm}$ , PTIME = 0xFF, PPULSE = 1 <sup>(3)</sup>	0.175	0.211	0.247	counts/ $\mu\text{W}/\text{cm}^2$	
Noise <sup>(1) (2) (3)</sup>	$E_e = 0$ , PTIME = 0xFF, PPULSE = 8 <sup>(6)</sup>		2		% FS	
LED pulse count <sup>(1)</sup>		0		255	pulses	
LED pulse period			14.0		$\mu\text{s}$	
LED pulse width – LED on time			6.3		$\mu\text{s}$	
LED drive current	$I_{SINK}$ sink current @ 1.6 V, LDR pin	PDRIVE = 0	80	106	132	mA
		PDRIVE = 1		50		
		PDRIVE = 2		25		
		PDRIVE = 3		12.5		
Maximum operating distance <sup>(1) (4) (5)</sup>	PDRIVE = 0 (100 mA), PPULSE = 64 <b>Emitter:</b> $\lambda_p = 850\text{ nm}$ , $20^\circ$ half angle, and $60\text{ mW}/\text{sr}$ <b>Object:</b> $16 \times 20$ -inch, 90% reflective Kodak Gray Card (white surface) <b>Optics:</b> Open view (no glass, no optical attenuation)		30		inches	

**Note(s):**

- Parameter is ensured by design or characterization and is not tested.
- Proximity noise is defined as one standard deviation of 600 samples.
- Proximity noise typically increases as  $\sqrt{PPULSE}$
- Greater operating distances are achievable with appropriate optical system design considerations. See available **ams** application notes for additional information.
- Maximum operating distance is dependent upon emitter and the reflective properties of the object's surface.
- Proximity noise test was done using the Figure 11, "Proximity Noise Test Circuit," on page 9.



**Figure 11:**  
Proximity Noise Test Circuit

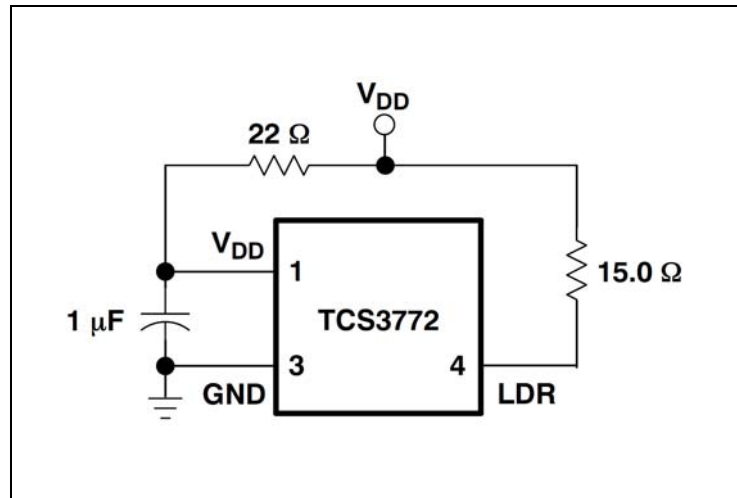

**Figure 12:**  
Wait Characteristics,  $V_{DD} = 3\text{ V}$ ,  $T_A = 25^\circ\text{C}$ ,  $WEN = 1$  (unless otherwise noted)

Parameter	Conditions	Channel	Min	Typ	Max	Units
Wait step size	WTIME = 0xFF		2.27	2.4	2.56	ms
Wait number of steps <sup>(1)</sup>			1		256	steps

**Note(s):**

1. Parameter ensured by design and is not tested.

## Timing Characteristics

The timing characteristics of TCS3772 are given below.

**Figure 13:**  
AC Electrical Characteristics,  $V_{DD} = 3\text{ V}$ ,  $T_A = 25^\circ\text{C}$  (unless otherwise noted)

Parameter <sup>(1)</sup>	Description	Min	Max	Units
$f_{(SCL)}$	Clock frequency (I <sup>2</sup> C only)	0	400	kHz
$t_{(BUF)}$	Bus free time between start and stop condition	1.3		$\mu\text{s}$
$t_{(HDSTA)}$	Hold time after (repeated) start condition. After this period, the first clock is generated.	0.6		$\mu\text{s}$
$t_{(SUSTA)}$	Repeated start condition setup time	0.6		$\mu\text{s}$
$t_{(SUSTO)}$	Stop condition setup time	0.6		$\mu\text{s}$
$t_{(HDDAT)}$	Data hold time	0		$\mu\text{s}$
$t_{(SUDAT)}$	Data setup time	100		ns
$t_{(LOW)}$	SCL clock low period	1.3		$\mu\text{s}$
$t_{(HIGH)}$	SCL clock high period	0.6		$\mu\text{s}$
$t_F$	Clock/data fall time		300	ns
$t_R$	Clock/data rise time		300	ns
$C_i$	Input pin capacitance		10	pF

**Note(s):**

1. Specified by design and characterization; not production tested.

## Timing Diagrams

**Figure 14:**  
Parameter Measurement Information

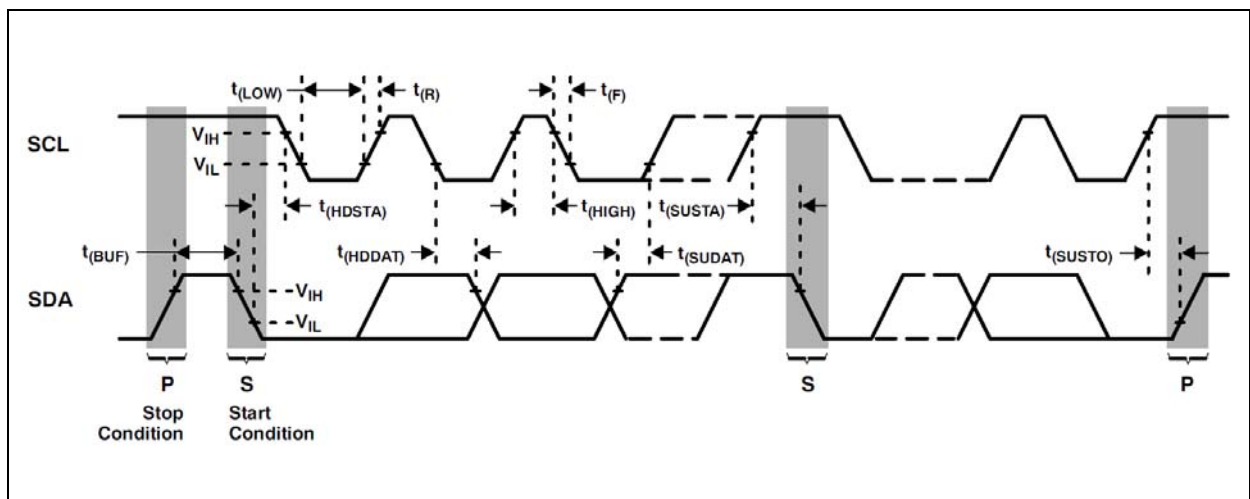

## Typical Operating Characteristics

Figure 15:  
Photodiode Spectral Responsivity RGBC

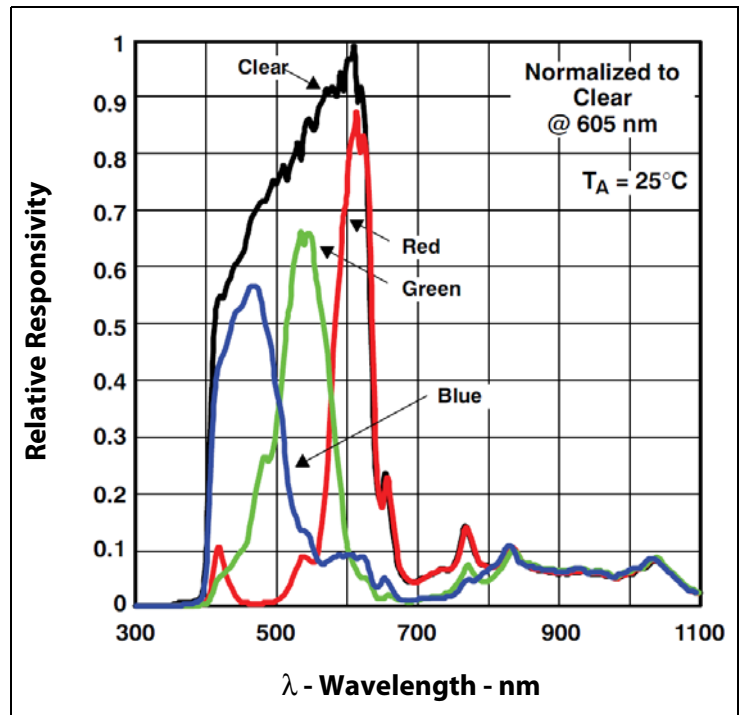

Figure 16:  
Photodiode Spectral Responsivity Proximity

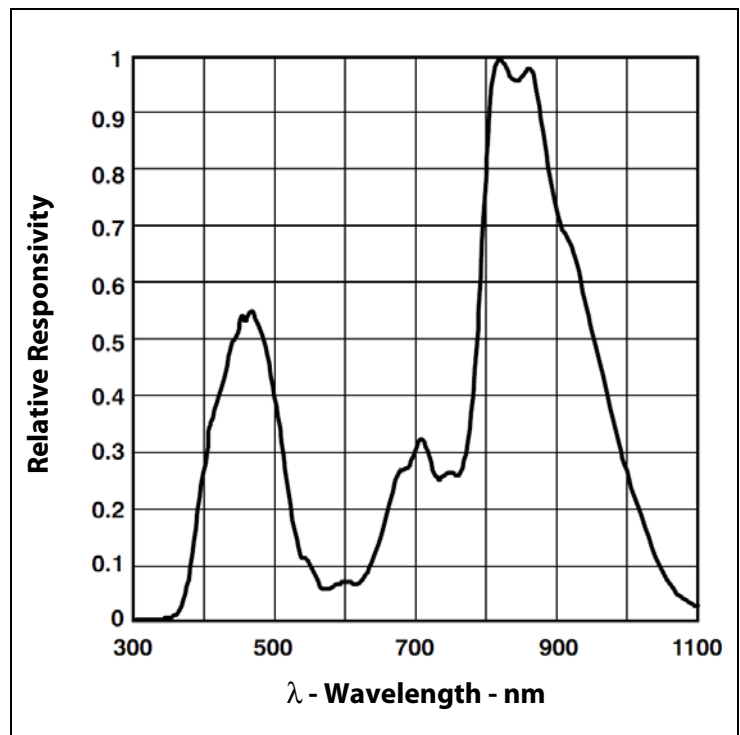

Figure 17:  
Normalized Responsivity vs. Angular Displacement

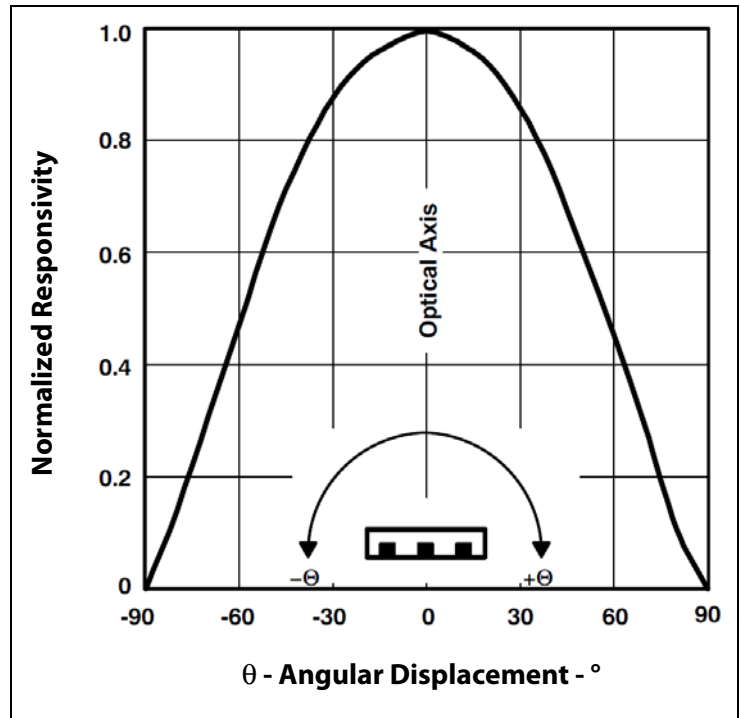
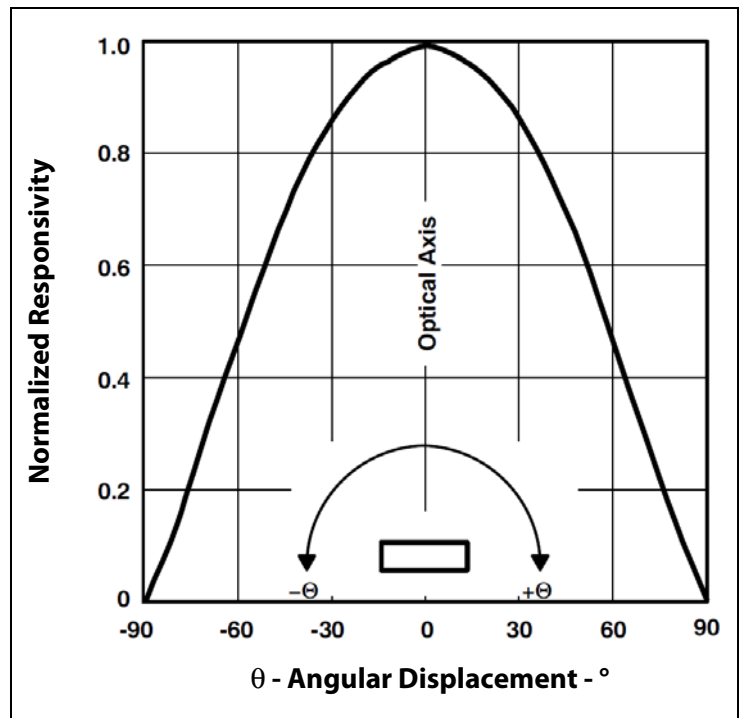
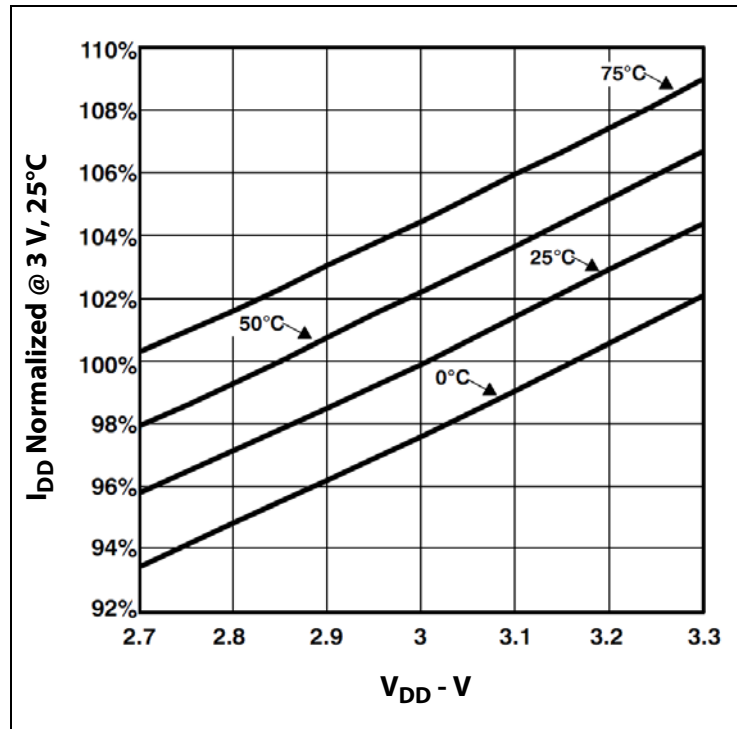

Figure 18:  
Normalized Responsivity vs. Angular Displacement



**Figure 19:**  
Normalized  $I_{DD}$  vs.  $V_{DD}$  and Temperature



**Figure 20:**  
Typical LDR Current vs. Voltage

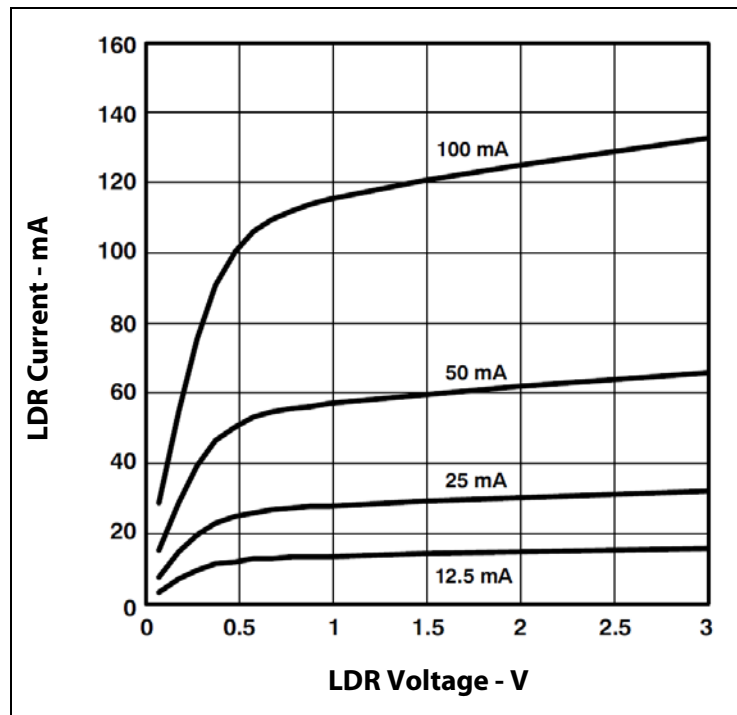
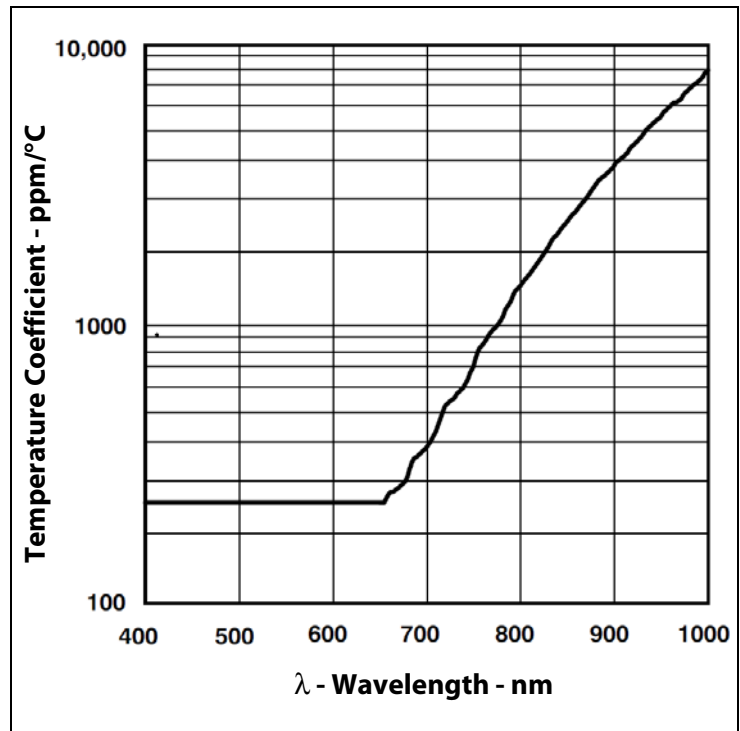

Figure 21:  
Responsivity Temperature Coefficient



## Detailed Description

The TCS3772 is a next-generation digital color light sensor device containing four integrating analog-to-digital converters (ADCs) that integrate currents from photodiodes. The device contains a  $3 \times 4$  photodiode array used for color measurements and a  $1 \times 4$  photodiode array used for proximity measurements. Integration of all color sensing channels occurs simultaneously. Upon completion of the conversion cycle, the conversion result is transferred to the corresponding data registers. The transfers are double-buffered to ensure that the integrity of the data is maintained. Communication with the device is accomplished through a fast (up to 400 kHz), two-wire I<sup>2</sup>C serial bus for easy connection to a microcontroller or embedded controller.

The device provides a separate pin for level-style interrupts. The interrupt feature simplifies and improves system efficiency by eliminating the need to poll a sensor for a light intensity value. When interrupts are enabled, an interrupt is generated when the value of a clear channel or proximity conversion is greater than an upper threshold or less than a lower threshold. Once the interrupt is asserted, it remains asserted until cleared by the controlling firmware. In addition, a programmable interrupt persistence filter allows the user to set the number of consecutive clear channel or proximity conversions outside of the threshold region that are necessary to trigger an interrupt. Interrupt thresholds and persistence filter settings are configured independently for both clear and proximity.

Proximity detection requires only a single external IR LED. An internal LED driver can be configured to provide a constant current sink of 12.5 mA, 25 mA, 50 mA, or 100 mA of current. No external current limiting resistor is required. The number of proximity LED pulses can be programmed from 1 to 255 pulses. Each pulse has a 14- $\mu$ s period.

## Principles of Operation

### System State Machine

The TCS3772 provides control of RGBC, proximity detection, and power management functionality through an internal state machine (Figure 22). After a power-on-reset, the device is in the sleep mode. As soon as the PON bit is set, the device will move to the start state. It will then continue through the Prox, Wait, and RGBC states. If these states are enabled, the device will execute each function. If the PON bit is set to 0, the state machine will continue until all conversions are completed and then go into a low power sleep mode.

**Figure 22:**  
Simplified State Diagram

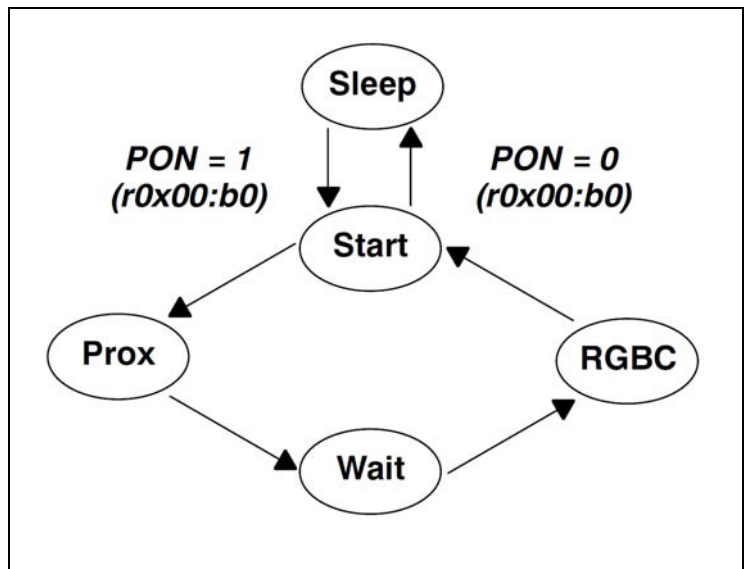

**Note(s):** In this document, the nomenclature uses the bit field name in italics followed by the register number and bit number to allow the user to easily identify the register and bit that controls the function. For example, the power on (PON) is in register 0, bit 0. This is represented as PON (r0x00:b0).



## RGBC Operation

The RGBC engine contains RGBC gain control (AGAIN) and four integrating analog-to-digital converters (ADC) for the RGBC photodiodes. The RGBC integration time (ATIME) impacts both the resolution and the sensitivity of the RGBC reading. Integration of all four channels occurs simultaneously and upon completion of the conversion cycle, the results are transferred to the color data registers. This data is also referred to as channel count. The transfers are double-buffered to ensure that invalid data is not read during the transfer. After the transfer, the device automatically moves to the next state in accordance with the configured state machine.

**Figure 23:**  
RGBC Operation

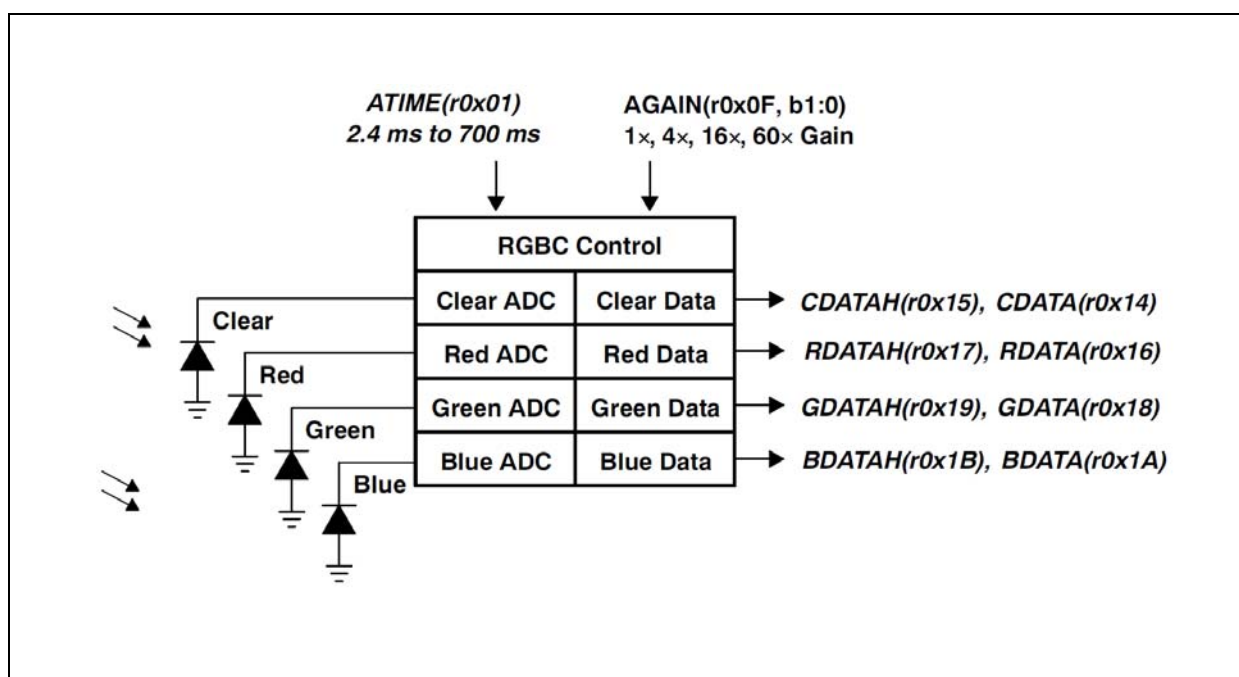

The registers for programming the integration and wait times are a 2's complement values. The actual time can be calculated as follows:

$$ATIME = 256 - \text{Integration Time} / 2.4 \text{ ms}$$

Inversely, the time can be calculated from the register value as follows:

$$\text{Integration Time} = 2.4 \text{ ms} \times (256 - ATIME)$$

For example, if a 100-ms integration time is needed, the device needs to be programmed to:

$$256 - (100 / 2.4) = 256 - 42 = 214 = 0xD6$$

Conversely, the programmed value of 0xC0 would correspond to:

$$(256 - 0xC0) \times 2.4 = 64 \times 2.4 = 154 \text{ ms}$$

## Proximity Detection

Proximity detection is accomplished by measuring the amount of light energy, generally from an IR LED, reflected off an object to determine its distance. The proximity light source, which is external to the TCS3772 device, is driven by the integrated proximity LED current driver.

**Figure 24:**  
Proximity Detection

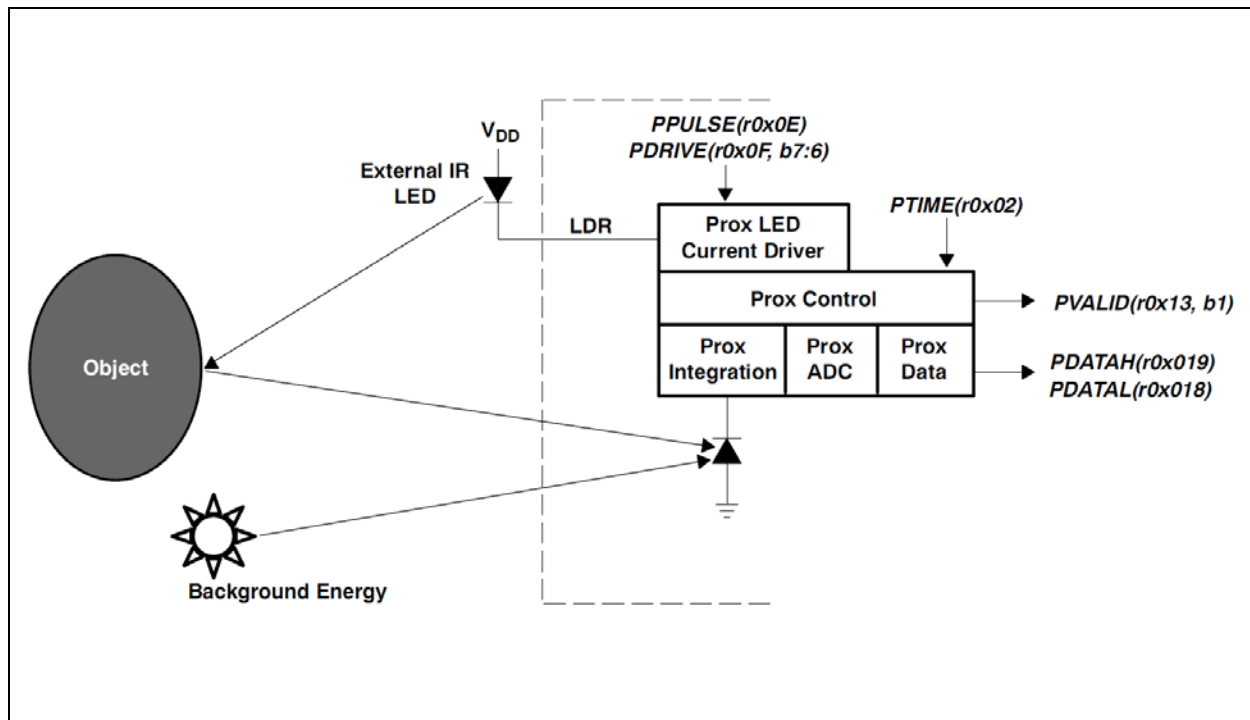

The LED current driver, output on the LDR terminal, provides a regulated current sink that eliminates the need for an external current limiting resistor. PDRIVE sets the drive current to 100 mA, 50 mA, 25 mA. To drive an external light source with more than 100 mA or to minimize on-chip ground bounce, LDR can be used to drive an external p-type transistor, which, in turn, drives the light source.

Referring to the Detailed State Machine figure, the LED current driver pulses the external IR LED as shown in Figure 25 during the Prox Accum state. Figure 25 also illustrates that the LED On pulse has a fixed width of 6.3  $\mu$ s and period of 14.0  $\mu$ s. So, in addition to setting the proximity drive current, 1 to 255 proximity pulses (PPULSE) can be programmed. When deciding on the number of proximity pulses, keep in mind that the signal increases proportionally to PPULSE, while noise increases by the square root of PPULSE.

**Figure 25:**  
Proximity LED Current Driver Waveform

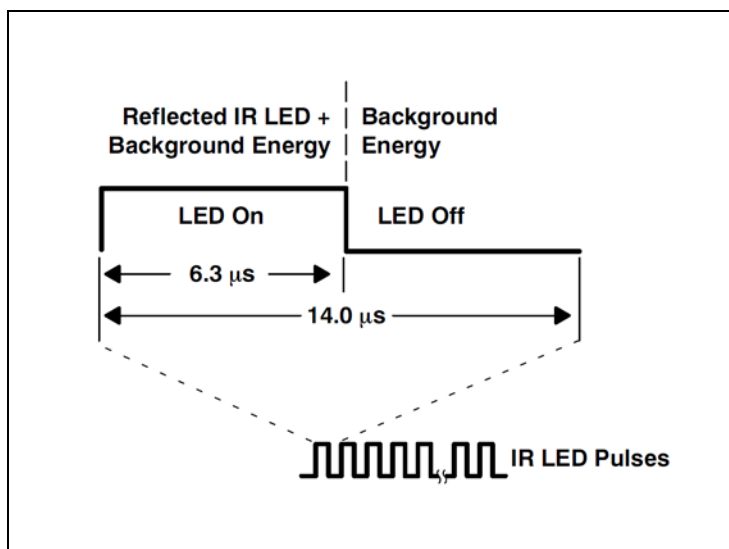

Figure 24 illustrates light rays emitting from an external IR LED, reflecting off an object, and being absorbed by the proximity photodiode.

Referring again to Figure 25, the reflected IR LED and the background energy is integrated during the LED On time, then during the LED Off time, the integrated background energy is subtracted from the LED On time energy, leaving the external IR LED energy to accumulate from pulse to pulse.

After the programmed number of proximity pulses have been generated, the proximity ADC converts and scales the proximity measurement to a 16-bit value, then stores the result in two 8-bit proximity data (PDATAx) registers. ADC scaling is controlled by the proximity ADC conversion time (PTIME) which is programmable from 1 to 256 2.4-ms time units. However, depending on the application, scaling the proximity data will equally scale any accumulated noise. Therefore, in general, it is recommended to leave PTIME at the default value of one 2.4-ms ADC conversion time (0xFF).

Once the first proximity cycle has completed, the proximity valid (PVALID) bit in the Status register will be set and remain set until the proximity detection function is disabled (PEN).

For additional information on using the proximity detection function behind glass and for optical system design guidance, please see available **ams** application notes.

### Interrupts

The interrupt feature simplifies and improves system efficiency by eliminating the need to poll the sensor for light intensity or proximity values outside of a user-defined range. While the interrupt function is always enabled and its status is available in the status register (0x13), the output of the interrupt state can be enabled using the proximity interrupt enable (PIEN) or Clear interrupt enable (AIEN) fields in the enable register (0x00).

Four 16-bit interrupt threshold registers allow the user to set limits below and above a desired light level and proximity range. An interrupt can be generated when the Clear data (CDATA) is less than the Clear interrupt low threshold registers (AILTx) or greater than the Clear interrupt high threshold registers (AIHTx). Likewise, an out-of-range proximity interrupt can be generated when the proximity data (PDATA) falls below the proximity interrupt low threshold (PILTx) or exceeds the proximity interrupt high threshold (PIHTx).

It is important to note that the thresholds are evaluated in sequence, first the low threshold, then the high threshold. As a result, if the low threshold is set above the high threshold, the high threshold is ignored and only the low threshold is evaluated.

To further control when an interrupt occurs, the device provides a persistence filter. The persistence filter allows the user to specify the number of consecutive out-of-range Clear or proximity occurrences before an interrupt is generated. The persistence register (0x0C) allows the user to set the Clear persistence (APERS) and the proximity persistence (PPERS) values. See the persistence register for details on the persistence filter values. Once the persistence filter generates an interrupt, it will continue until a special function interrupt clear command is received (see command register).

Figure 26: Programmable Interrupt

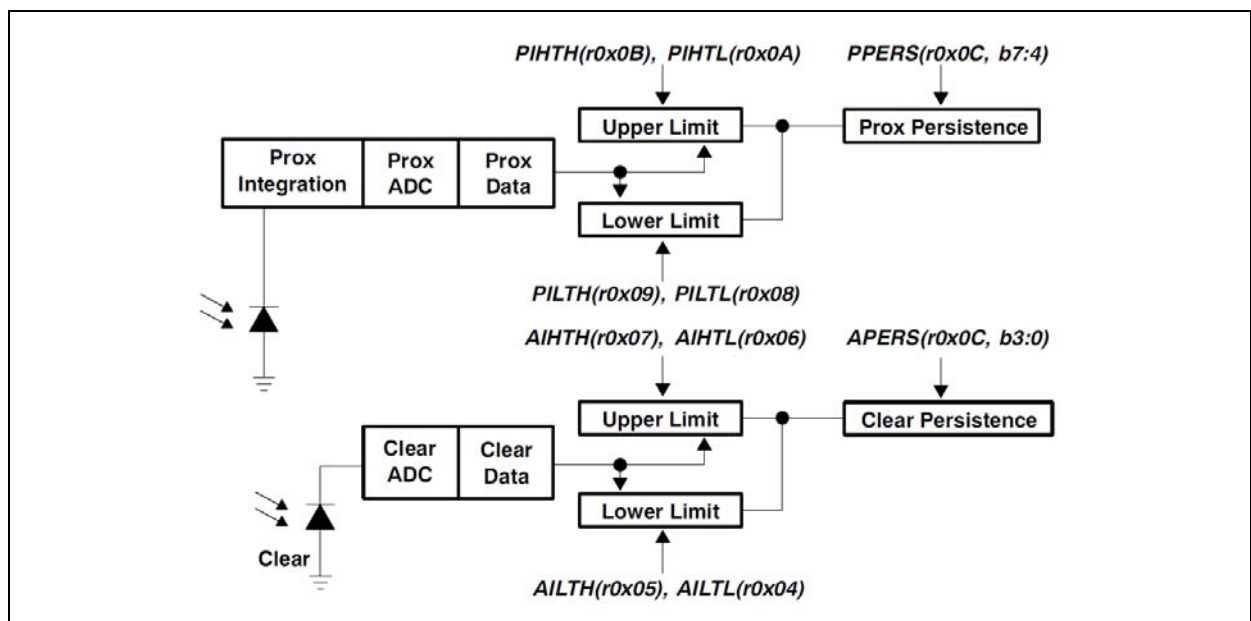

## System Timing

The system state machine shown in [Figure 22](#) provides an overview of the states and state transitions that provide system control of the device. This section highlights the programmable features, which affect the state machine cycle time, and provides details to determine system level timing.

When the proximity detection feature is enabled (PEN), the state machine transitions through the Prox Accum, Prox Wait, and Prox ADC states. The Prox Wait time is a fixed 2.4ms, whereas the Prox Accum time is determined by the number of proximity LED pulses (PPULSE) and the Prox ADC time is determined by the integration time (PTIME). The formulas to determine the Prox Accum and Prox ADC times are given in the associated boxes in [Figure 27](#). If an interrupt is generated as a result of the proximity cycle, it will be asserted at the end of the Prox ADC state.

When the power management feature is enabled (WEN), the state machine will transition in turn to the Wait state. The wait time is determined by WLONG, which extends normal operation by 12× when asserted, and WTIME. The formula to determine the wait time is given in the box associated with the Wait state in [Figure 27](#).

When the RGBC feature is enabled (AEN), the state machine will transition through the RGBC Init and RGBC ADC states. The RGBC Init state takes 2.4 ms, while the RGBC ADC time is dependent on the integration time (ATIME). The formula to determine RGBC ADC time is given in the associated box in [Figure 27](#). If an interrupt is generated as a result of the RGBC cycle, it will be asserted at the end of the RGBC ADC.

**Figure 27:**  
Detailed State Diagram

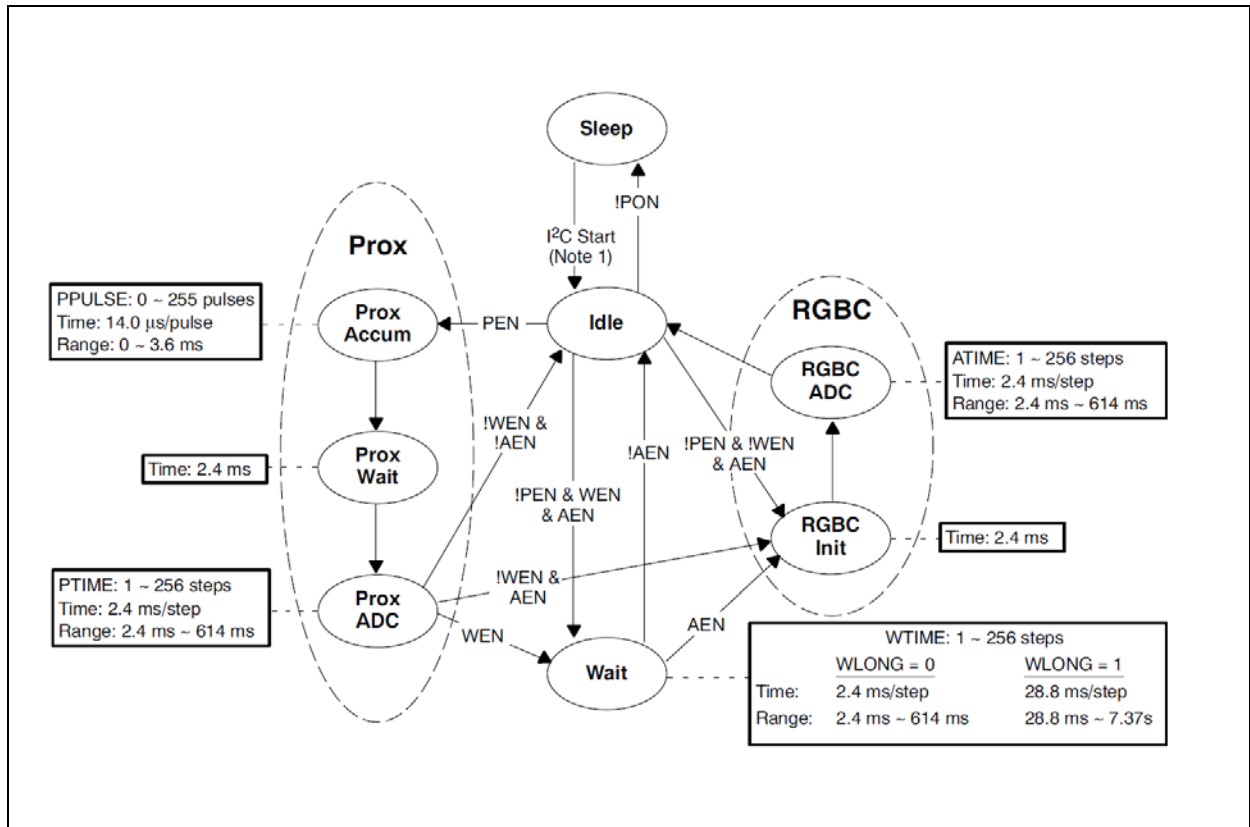

**Note(s):**

1. There is a 2.4 ms warm-up delay if PON is enabled. If PON is not enabled, the device will return to the Sleep state as shown.
2. PON, PEN, WEN, and AEN are fields in the Enable register (0x00).

## Power Management

Power consumption can be managed with the Wait state, because the Wait state typically consumes only 65  $\mu\text{A}$  of  $I_{\text{DD}}$  current. An example of the power management feature is given below. With the assumptions provided in the example, average  $I_{\text{DD}}$  is estimated to be 186  $\mu\text{A}$ .

**Figure 28:**  
Power Management

System State Machine State	Programmable Parameter	Programmed Value	Duration	Typical Current
Prox Accum	PPULSE	0x04	0.056 ms	
Prox Accum - LED ON			0.025 ms <sup>(1)</sup>	109 mA
Prox Accum - LED OFF			0.031 ms <sup>(2)</sup>	0.235 mA
Prox Wait			2.40 ms	0.235 mA
Prox ADC	PTIME	0xFF	2.40 ms	0.235 mA
Wait	WTIME	0xEE	43.1 ms	0.065 mA
	WLONG	0		
ALS Init			2.40 ms	0.235 mA
ALS ADC	ATIME	0xEE	43.1 ms	0.235 mA

**Note(s):**

- Prox Accum - LED ON time = 6.3  $\mu\text{s}$  per pulse  $\times$  4 pulses = 25.2  $\mu\text{s}$  = 0.025 ms
- Prox Accum - LED OFF time = 7.7  $\mu\text{s}$  per pulse  $\times$  4 pulses = 30.9  $\mu\text{s}$  = 0.031 ms

$$\text{Average } I_{\text{DD}} \text{ Current} = ((0.025 \times 109) + (0.031 \times 0.235) + (2.40 \times 0.235) + (43.1 \times 0.065) + (43.1 \times 0.263) + (2.40 \times 0.235 \times 2)) / 93 \approx 186 \mu\text{A}$$

Keeping with the same programmed values as the example, [Figure 29](#) shows how the average  $I_{\text{DD}}$  current is affected by the Wait state time, which is determined by WEN, WTIME, and WLONG. Note that the worst-case current occurs when the Wait state is not enabled.

**Figure 29:**  
Average  $I_{\text{DD}}$  Current

WEN	WTIME	WLONG	WAIT State	Average $I_{\text{DD}}$ Current
0	n/a	n/a	0 ms	289 $\mu\text{A}$
1	0xFF	0	2.40 ms	279 $\mu\text{A}$
1	0xEE	0	43.1 ms	186 $\mu\text{A}$
1	0x00	0	613 ms	82 $\mu\text{A}$
1	0x00	1	7.36 s	67 $\mu\text{A}$

## I<sup>2</sup>C Protocol

Interface and control are accomplished through an I<sup>2</sup>C serial compatible interface (standard or fast mode) to a set of registers that provide access to device control functions and output data. The devices support the 7-bit I<sup>2</sup>C addressing protocol.

The I<sup>2</sup>C standard provides for three types of bus transaction: read, write, and a combined protocol (Figure 30). During a write operation, the first byte written is a command byte followed by data. In a combined protocol, the first byte written is the command byte followed by reading a series of bytes. If a read command is issued, the register address from the previous command will be used for data access. Likewise, if the MSB of the command is not set, the device will write a series of bytes at the address stored in the last valid command with a register address. The command byte contains either control information or a 5-bit register address. The control commands can also be used to clear interrupts.

The I<sup>2</sup>C bus protocol was developed by Philips (now NXP). For a complete description of the I<sup>2</sup>C protocol, please review the NXP I<sup>2</sup>C design specification at:

<http://www.i2c-bus.org/references/>.

Figure 30:  
I<sup>2</sup>C Protocols

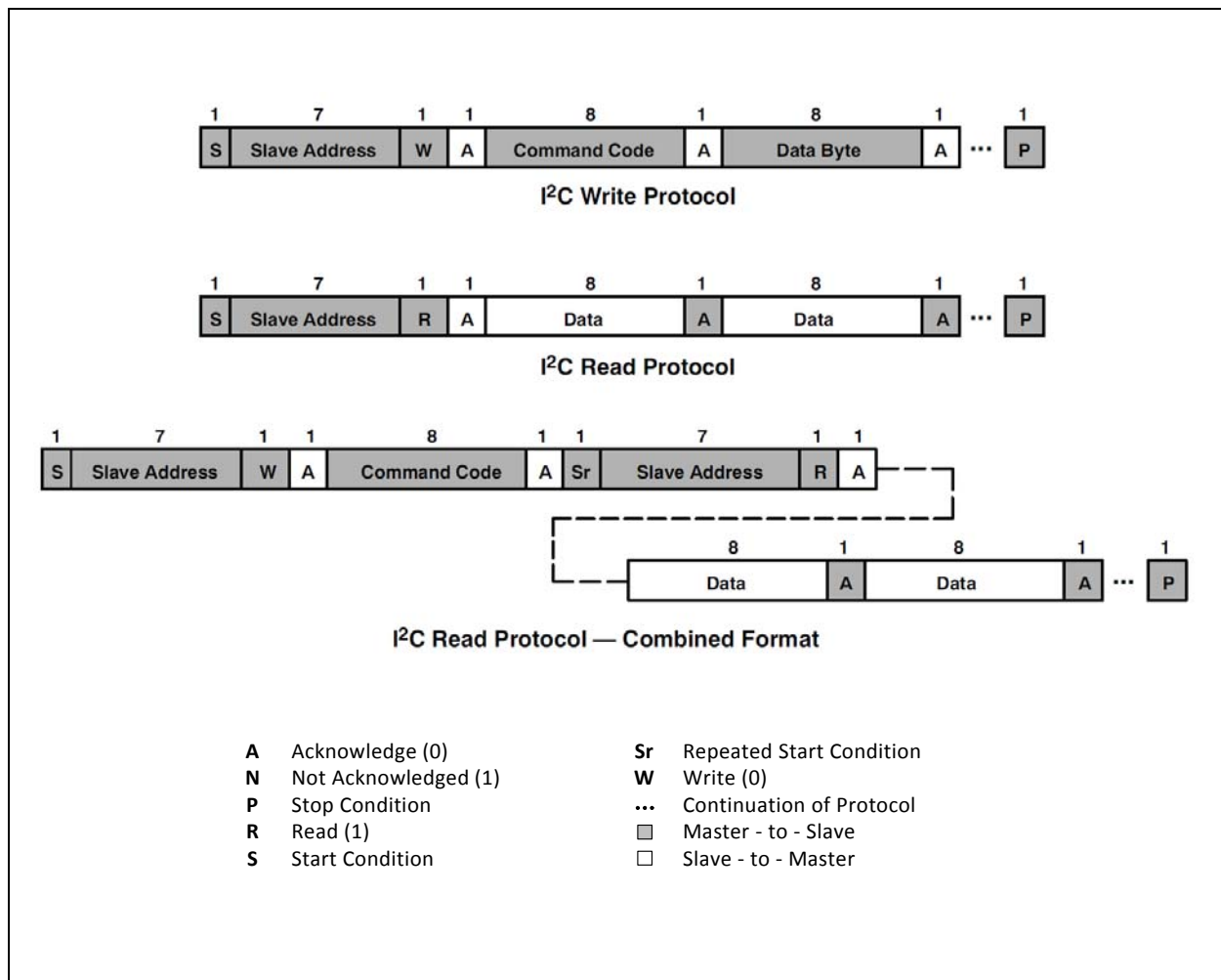



## Register Description

The TCS3772 is controlled and monitored by data registers and a command register accessed through the serial interface.

These registers provide for a variety of control functions and can be read to determine results of the ADC conversions. The register set is summarized in [Figure 31](#).

**Figure 31:**  
Register Set

Address	Register Name	R/W	Register Function	Reset Value
--	COMMAND	W	Specifies register address	0x00
0x00	ENABLE	R/W	Enables states and interrupts	0x00
0x01	ATIME	R/W	RGBC time	0xFF
0x02	PTIME	R/W	Proximity time	0xFF
0x03	WTIME	R/W	Wait time	0xFF
0x04	AILTL	R/W	Clear interrupt low threshold low byte	0x00
0x05	AILTH	R/W	Clear interrupt low threshold high byte	0x00
0x06	AIHTL	R/W	Clear interrupt high threshold low byte	0x00
0x07	AIHTH	R/W	Clear interrupt high threshold high byte	0x00
0x08	PILTL	R/W	Proximity interrupt low threshold low byte	0x00
0x09	PILTH	R/W	Proximity interrupt low threshold high byte	0x00
0x0A	PIHTL	R/W	Proximity interrupt high threshold low byte	0x00
0x0B	PIHTH	R/W	Proximity interrupt high threshold high byte	0x00
0x0C	PERS	R/W	Interrupt persistence filters	0x00
0x0D	CONFIG	R/W	Configuration	0x00
0x0E	PPULSE	R/W	Proximity pulse count	0x00
0x0F	CONTROL	R/W	Gain control register	0x00
0x12	ID	R	Device ID	ID
0x13	STATUS	R	Device status	0x00
0x14	CDATA	R	Clear ADC data low byte	0x00
0x15	CDATAH	R	Clear ADC data high byte	0x00
0x16	RDATA	R	Red ADC data low byte	0x00
0x17	RDATAH	R	Red ADC data high byte	0x00
0x18	GDATA	R	Green ADC data low byte	0x00
0x19	GDATAH	R	Green ADC data high byte	0x00

Address	Register Name	R/W	Register Function	Reset Value
0x1A	BDATA	R	Blue ADC data low byte	0x00
0x1B	BDATAH	R	Blue ADC data high byte	0x00
0x1C	PDATA	R	Proximity ADC data low byte	0x00
0x1D	PDATAH	R	Proximity ADC data high byte	0x00

The mechanics of accessing a specific register depends on the specific protocol used. See the section on I<sup>2</sup>C protocols on the previous pages. In general, the COMMAND register is written first to specify the specific control/status register for following read/write operations.

### Command Register

The COMMAND registers specifies the address of the target register for future write and read operations.

**Figure 32:**  
Command Register

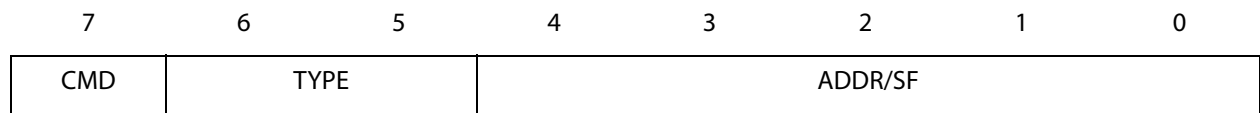

Field	Bits	Description	
CMD	7	Select Command Register. Must write as 1 when addressing COMMAND register.	
TYPE	6:5	Selects type of transaction to follow in subsequent data transfers:	
		<b>FIELD VALUE</b>	<b>INTEGRATION TIME</b>
		00	Repeated byte protocol transaction
		01	Auto-increment protocol transaction
		10	Reserved – Do not use
		11	Special function – See description below
		Byte protocol will repeatedly read the same register with each data access. Block protocol will provide auto-increment function to read successive bytes.	
ADDR/SF	4:0	Address field/special function field. Depending on the transaction type, see above, this field either specifies a special function command or selects the specific control-status-register for following write and read transactions. The field values listed below apply only to special function commands:	
		<b>FIELD VALUE</b>	<b>READ VALUE</b>
		00101	Proximity interrupt clear
		00110	Clear channel interrupt clear
		00111	Proximity and Clear interrupt clear
		Other	Reserved – Do not write
		The ALS and Proximity interrupt clear special functions clear any pending interrupt(s) and are self clearing.	

### Enable Register (0x00)

The ENABLE register is used primarily to power the TCS3772 device on and off, and enable functions and interrupts as shown below.

**Figure 33:**  
Enable Register

7	6	5	4	3	2	1	0
Reserved	PIEN	AIEN	WEN	PEN	AEN	PON	

Fields	Bits	Description
Reserved	7:6	Reserved. Write as 0.
PIEN	5	Proximity interrupt enable. When asserted, permits proximity interrupts to be generated.
AIEN	4	Clear channel interrupt enable. When asserted, permits Clear interrupts to be generated.
WEN	3	Wait enable. This bit activates the wait feature. Writing a 1 activates the wait timer. Writing a 0 disables the wait timer.
PEN	2	Proximity enable. This bit activates the proximity function. Writing a 1 enables proximity. Writing a 0 disables proximity.
AEN	1	RGBC enable. This bit activates the two-channel ADC. Writing a 1 activates RGBC. Writing a 0 disables RGBC.
PON	0	Power ON. This bit activates the internal oscillator to permit the timers and ADC channels to operate. Writing a 1 activates the oscillator. Writing a 0 disables the oscillator. During reads and writes over the I <sup>2</sup> C interface, this bit is temporarily overridden and the oscillator is enabled, independent of the state of PON.

### RGBC Time Register (0x01)

The RGBC timing register controls the internal integration time of the RGBC clear and IR channel ADCs in 2.4-ms increments. Upon power up, the RGBC time register is set to 0xFF.

**Figure 34:**  
RGBC Time Register

Fields	Bits	Description			
		VALUE	INTEG_CYCLES	TIME	MAX COUNT
ATIME	7:0	0xFF	1	2.4 ms	1024
		0xF6	10	24 ms	10240
		0xD6	42	101 ms	43008
		0xAD	64	154 ms	65535
		0x00	256	614 ms	65535

### Proximity Time Register (0x02)

The proximity timing register controls the integration time of the proximity ADC in 2.4 ms increments. Upon power up, the proximity time register is set to 0xFF. It is recommended that this register be programmed to a value of 0xFF (1 integration cycle).

Max Prox Count = ((256 - PTIME) × 1024) - 1 up to a maximum of 65535.

**Figure 35:**  
Proximity Time Register

Fields	Bits	Description			
		VALUE	INTEG_CYCLES	TIME	MAX COUNT
PTIME	7:0	0xFF	1	2.4 ms	1023

### Wait Time Register (0x03)

Wait time is set 2.4 ms increments unless the WLONG bit is asserted, in which case the wait times are 12x longer. WTIME is programmed as a 2's complement number.

**Figure 36:**  
Wait Time Register

Fields	Bits	Description			
		REGISTER VALUE	WAIT TIME	TIME (WLONG = 0)	TIME (WLONG = 1)
WTIME	7:0	0xFF	1	2.4 ms	0.029 s
		0xAB	85	204 ms	2.45 s
		0x00	256	614 ms	7.4 s

**Note(s):**

1. The Proximity Wait Time Register should be configured before PEN and/or AEN is/are asserted.

### Clear Interrupt Threshold Registers (0x04 - 0x07)

The CLEAR INTERRUPT THRESHOLD registers provides the values to be used as the high and low trigger points for the comparison function for interrupt generation. If the value generated by the clear channel crosses below the lower threshold specified, or above the higher threshold, an interrupt is asserted on the interrupt pin.

**Figure 37:**  
Clear Interrupt Threshold Registers

Register	Address	Bits	Description
AILTL	0x04	7:0	Clear channel low threshold lower byte
AILTH	0x05	7:0	Clear channel low threshold upper byte
AIHTL	0x06	7:0	Clear channel high threshold lower byte
AIHTH	0x07	7:0	Clear channel high threshold upper byte

### Proximity Interrupt Threshold Registers (0x08 - 0x0B)

The PROXIMITY INTERRUPT THRESHOLD registers provide the values to be used as the high and low trigger points for the comparison function for interrupt generation. If the value generated by proximity channel crosses below the lower threshold specified, or above the higher threshold, an interrupt is signalled to the host processor.

**Figure 38:**  
Proximity Interrupt Threshold Registers

Register	Address	Bits	Description
PILTL	0x08	7:0	Proximity ADC channel low threshold lower byte
PILTH	0x09	7:0	Proximity ADC channel low threshold upper byte
PIHTL	0x0A	7:0	Proximity ADC channel high threshold lower byte
PIHTH	0x0B	7:0	Proximity ADC channel high threshold upper byte

### Persistence Filter Register (0x0C)

The PERSISTENCE FILTER register controls the filtering interrupt capabilities of the device. Configurable filtering is provided to allow interrupts to be generated after each integration cycle or if the integration has produced a result that is outside of the values specified by the threshold register for some specified amount of time. Separate filtering is provided for proximity and the clear channel.

**Figure 39:**  
Persistence Filter Register



Field	Bits	Description	
PPERS	7:4	Proximity interrupt persistence. Controls rate of proximity interrupt to the host processor.	
		<b>FIELD VALUE</b>	<b>INTERRUPT PERSISTENCE FUNCTION</b>
		0000	Every proximity cycle generates an interrupt
		0001	1 proximity value out of range
		0010	2 consecutive proximity values out of range
		...	...
1111	15 consecutive proximity values out of range		



Field	Bits	Description	
APERS	3:0	Clear Interrupt persistence. Controls rate of Clear channel interrupt to the host processor.	
		FIELD VALUE	INTERRUPT PERSISTENCE FUNCTION
		0000	Every RGBC cycle generates an interrupt
		0001	1 clear channel value outside of threshold range
		0010	2 clear channel consecutive values out of range
		0011	3 clear channel consecutive values out of range
		0100	5 clear channel consecutive values out of range
		0101	10 clear channel consecutive values out of range
		0110	15 clear channel consecutive values out of range
		0111	20 clear channel consecutive values out of range
		1000	25 clear channel consecutive values out of range
		1001	30 clear channel consecutive values out of range
		1010	35 clear channel consecutive values out of range
		1011	40 clear channel consecutive values out of range
		1100	45 clear channel consecutive values out of range
		1101	50 clear channel consecutive values out of range
		1110	55 clear channel consecutive values out of range
1111	60 clear channel consecutive values out of range		

### Configuration Register (0x0D)

The CONFIGURATION register sets the wait long time

**Figure 40:**  
Configuration Register

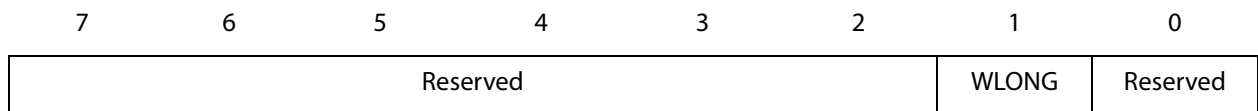

Fields	Bits	Description
Reserved	7:2	Reserved. Write as 0.
WLONG	1	Wait Long. When asserted, the wait cycles are increased by a factor 12× from that programmed in the WTIME register.
Reserved	0	Reserved. Write as 0.

### Proximity Pulse Count Register (0x0E)

The PROXIMITY pulse count register sets the number of proximity pulses that will be transmitted

**Figure 41:**  
Proximity Pulse Count Register

7	6	5	4	3	2	1	0
PPULSE							

Fields	Bits	Description
PPULSE	7:0	Proximity Pulse Count. Specifies the number of proximity pulses to be generated.

### Control Register (0x0F)

The CONTROL register provides eight bits of miscellaneous control to the analog block.

**Figure 42:**  
Control Register

7	6	5	4	3	2	1	0
PDRIVE		Reserved				AGAIN	

  

Fields	Bits	Description	
PDRIVE	7:6	Reserved. Write as 0.	
		FIELD VALUE	LED STRENGTH
		00	100 mA
		01	50 mA
		10	25 mA
11	12.5 mA		
Reserved	5:2	Reserved. Write bits as 0	
AGAIN	1:0	RGBC Gain Control.	
		FIELD VALUE	RGBC GAIN VALUE
		00	1× gain
		01	4× gain
		10	16× gain
11	60× gain		

### ID Register (0x12)

The ID Register provides the value for the part number. The ID register is a read-only register.

**Figure 43:**  
ID Register

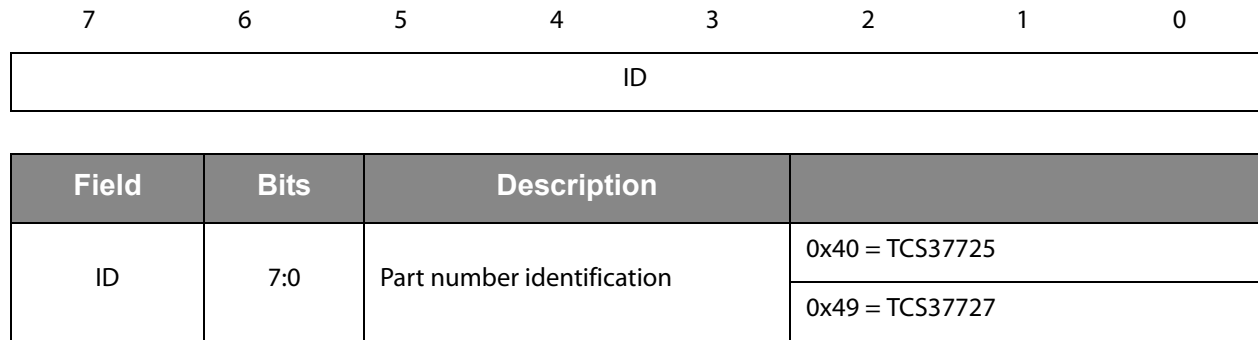

### Status Register (0x13)

The STATUS Register provides the internal status of the device. This register is read only.

**Figure 44:**  
Status Register

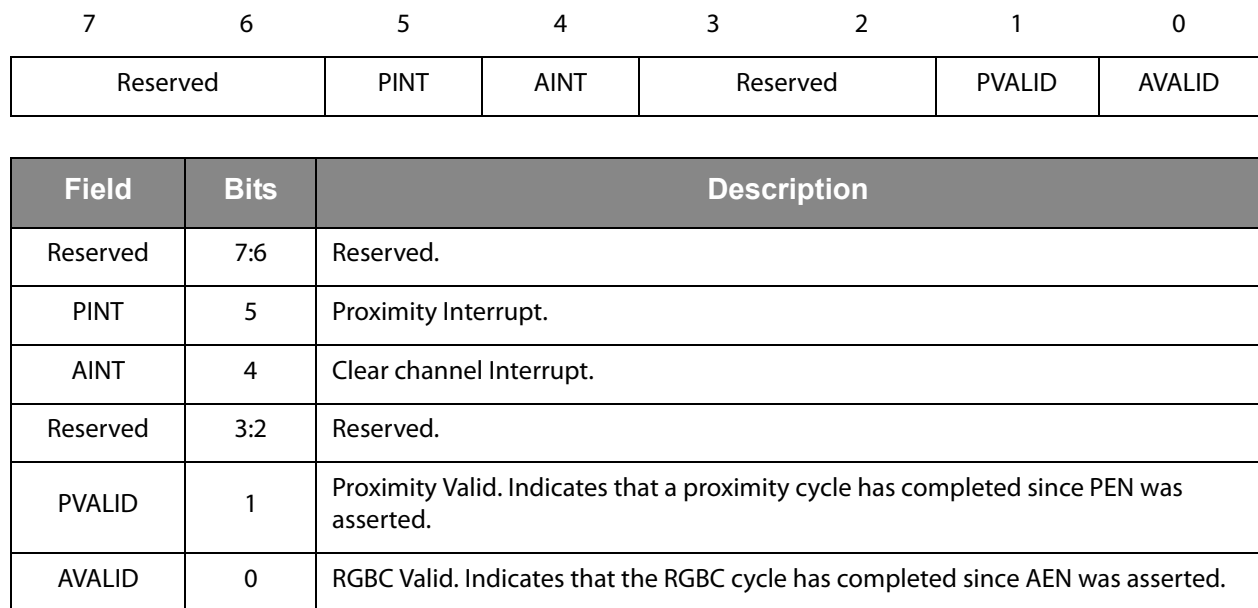

### RGBC Channel Data Registers (0x14 - 0x1B)

Clear, red, green, and blue data is stored as 16-bit values. To ensure the data is read correctly, a two-byte read I<sup>2</sup>C transaction should be used with a read word protocol bit set in the command register. With this operation, when the lower byte register is read, the upper eight bits are stored into a shadow register, which is read by a subsequent read to the upper byte. The upper register will read the correct value even if additional ADC integration cycles end between the reading of the lower and upper registers.

**Figure 45:**  
RGBC Channel Data Registers

Register	Address	Bits	Description
CDATA	0x14	7:0	Clear data low byte
CDATAH	0x15	7:0	Clear data high byte
RDATA	0x16	7:0	Red data low byte
RDATAH	0x17	7:0	Red data high byte
GDATA	0x18	7:0	Green data low byte
GDATAH	0x19	7:0	Green data high byte
BDATA	0x1A	7:0	Blue data low byte
BDATAH	0x1B	7:0	Blue data high byte

### Proximity Data Registers (0x1C - 0x1D)

Proximity data is stored as a 16-bit value. To ensure the data is read correctly, a two-byte read I<sup>2</sup>C transaction should be used with a read word protocol bit set in the command register. With this operation, when the lower byte register is read, the upper eight bits are stored into a shadow register, which is read by a subsequent read to the upper byte. The upper register will read the correct value even if additional ADC integration cycles end between the reading of the lower and upper registers.

**Figure 46:**  
Proximity Data Registers

Register	Address	Bits	Description
PDATA	0x1C	7:0	Proximity data low byte
PDATAH	0x1D	7:0	Proximity data high byte

## Application Information: Hardware

### LED Driver Pin with Proximity Detection

In a proximity sensing system, the IR LED can be pulsed by the TCS3772 with more than 100 mA of rapidly switching current, therefore, a few design considerations must be kept in mind to get the best performance. The key goal is to reduce the power supply noise coupled back into the device during the LED pulses.

The first recommendation is to use two power supplies; one for the device  $V_{DD}$  and the other for the IR LED. In many systems, there is a quiet analog supply and a noisy digital supply. By connecting the quiet supply to the  $V_{DD}$  pin and the noisy supply to the LED, the key goal can be met. Place a 1- $\mu\text{F}$  low-ESR decoupling capacitor as close as possible to the  $V_{DD}$  pin and another at the LED anode, and a 22- $\mu\text{F}$  capacitor at the output of the LED voltage regulator to supply the 100-mA current surge.

**Figure 47:**  
Proximity Sensing Using Separate Power Supplies

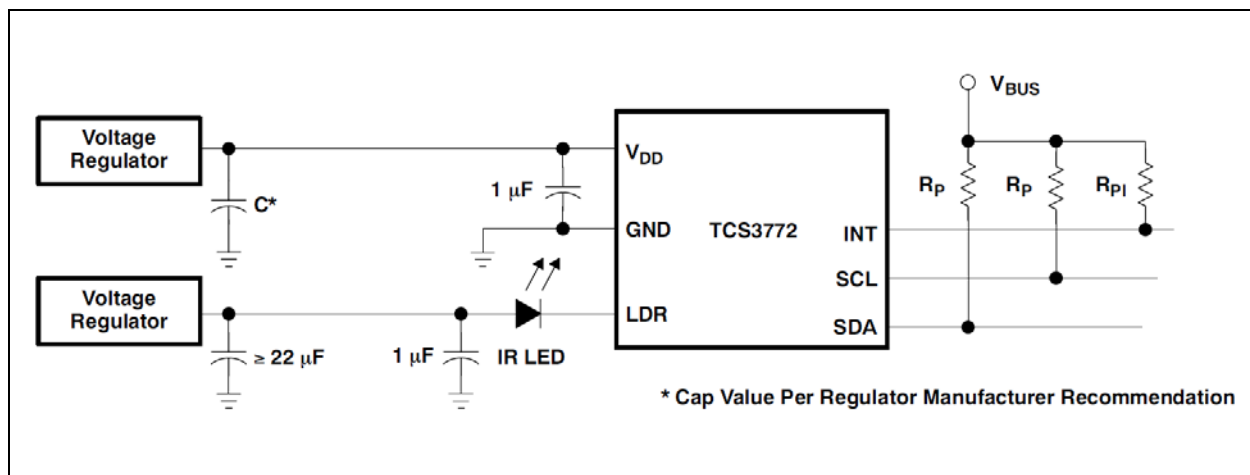

If it is not possible to provide two separate power supplies, the device can be operated from a single supply. A 22- $\Omega$  resistor in series with the  $V_{DD}$  supply line and a 1- $\mu\text{F}$  low ESR capacitor effectively filter any power supply noise. The previous capacitor placement considerations apply.

**Figure 48:**  
Proximity Sensing Using Single Power Supply

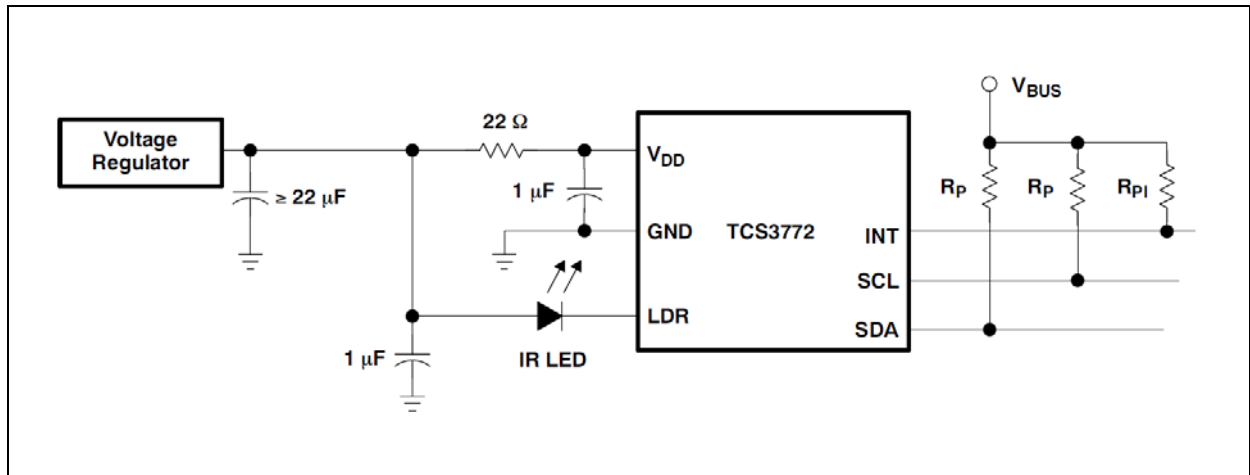

$V_{BUS}$  in the above figures refers to the I<sup>2</sup>C bus voltage which is either  $V_{DD}$  or 1.8 V. Be sure to apply the specified I<sup>2</sup>C bus voltage shown in the Available Options table for the specific device being used.

The I<sup>2</sup>C signals and the Interrupt are open-drain outputs and require pull-up resistors. The pull-up resistor ( $R_p$ ) value is a function of the I<sup>2</sup>C bus speed, the I<sup>2</sup>C bus voltage, and the capacitive load. The **ams** EVM running at 400 kbit/s, uses 1.5-kΩ resistors. A 10-kΩ pull-up resistor ( $R_{pi}$ ) can be used for the interrupt line.

## PCB Pad Layout

Suggested land pattern based on the IPC-7351B Generic Requirements for Surface Mount Design and Land Pattern Standard (2010) for the small outline no-lead (SON) package is shown in [Figure 49](#).

**Figure 49:**  
Suggested FN Package PCB Layout (Top View)

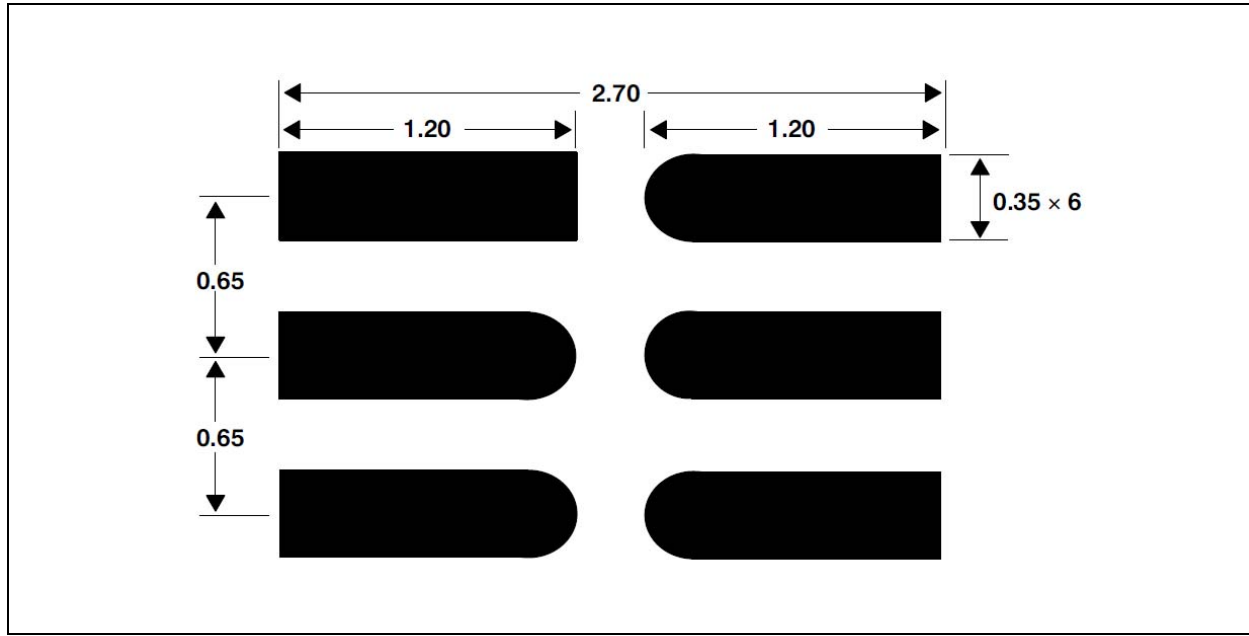

**Note(s):**

1. All linear dimensions are in millimeters.
2. This drawing is subject to change without notice.

## Package Drawings & Markings

Figure 50:  
Package FN – Dual Flat No-Lead Packaging Configuration

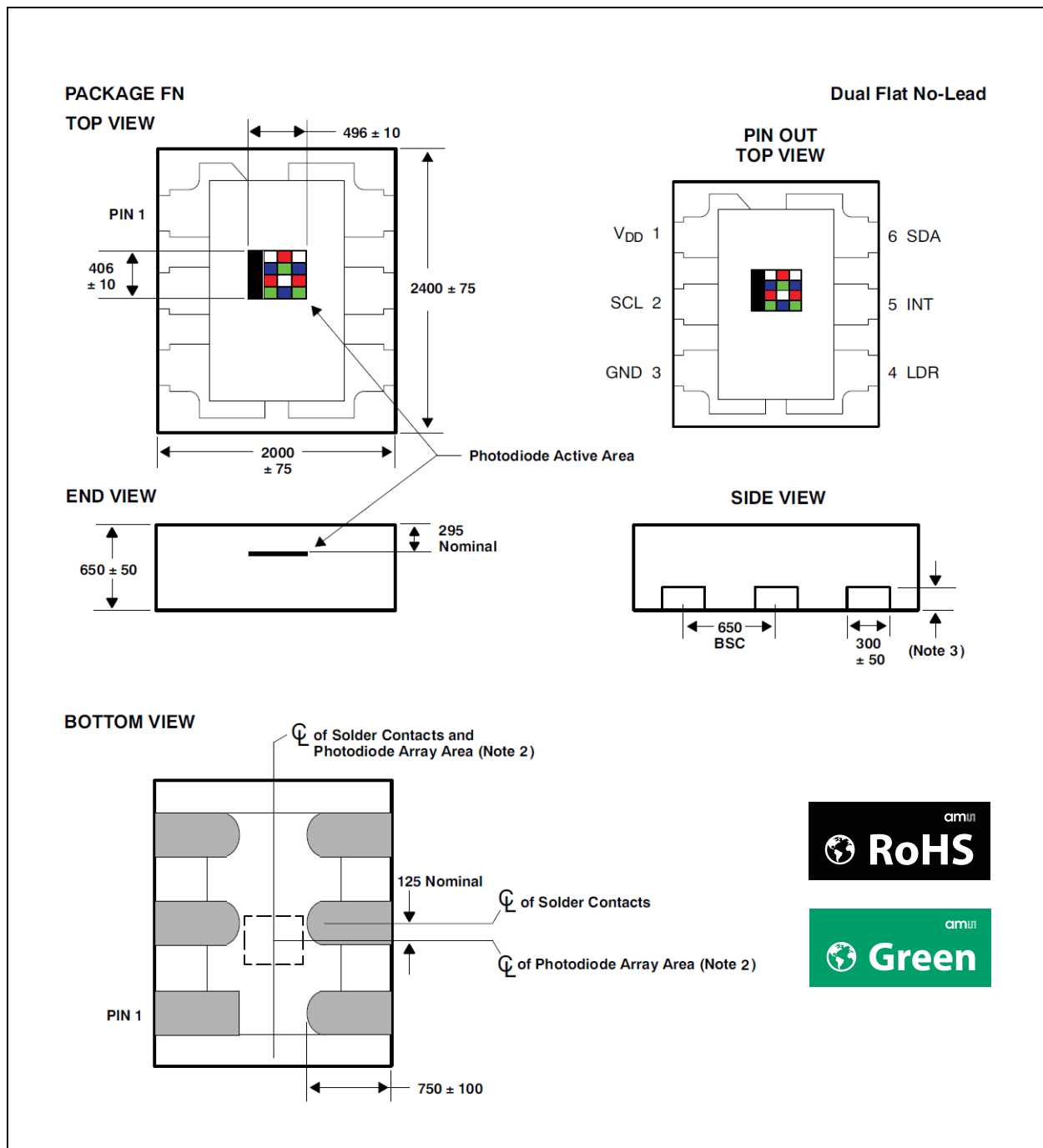

**Note(s):**

1. All linear dimensions are in micrometers.
2. The die is centered within the package within a tolerance of  $\pm 75 \mu\text{m}$ .
3. Double-Half Etch (DHE) is  $97 \pm 20 \mu\text{m}$ . Non-DHE is  $203 \pm 8 \mu\text{m}$ .
4. Package top surface is molded with an electrically nonconductive clear plastic compound having an index of refraction of 1.55.
5. Contact finish is copper alloy A194 with pre-plated NiPdAu lead finish.
6. This package contains no lead (Pb).
7. This drawing is subject to change without notice.



## Carrier Tape & Reel Information

**Figure 51:**  
Package FN Carrier Tape

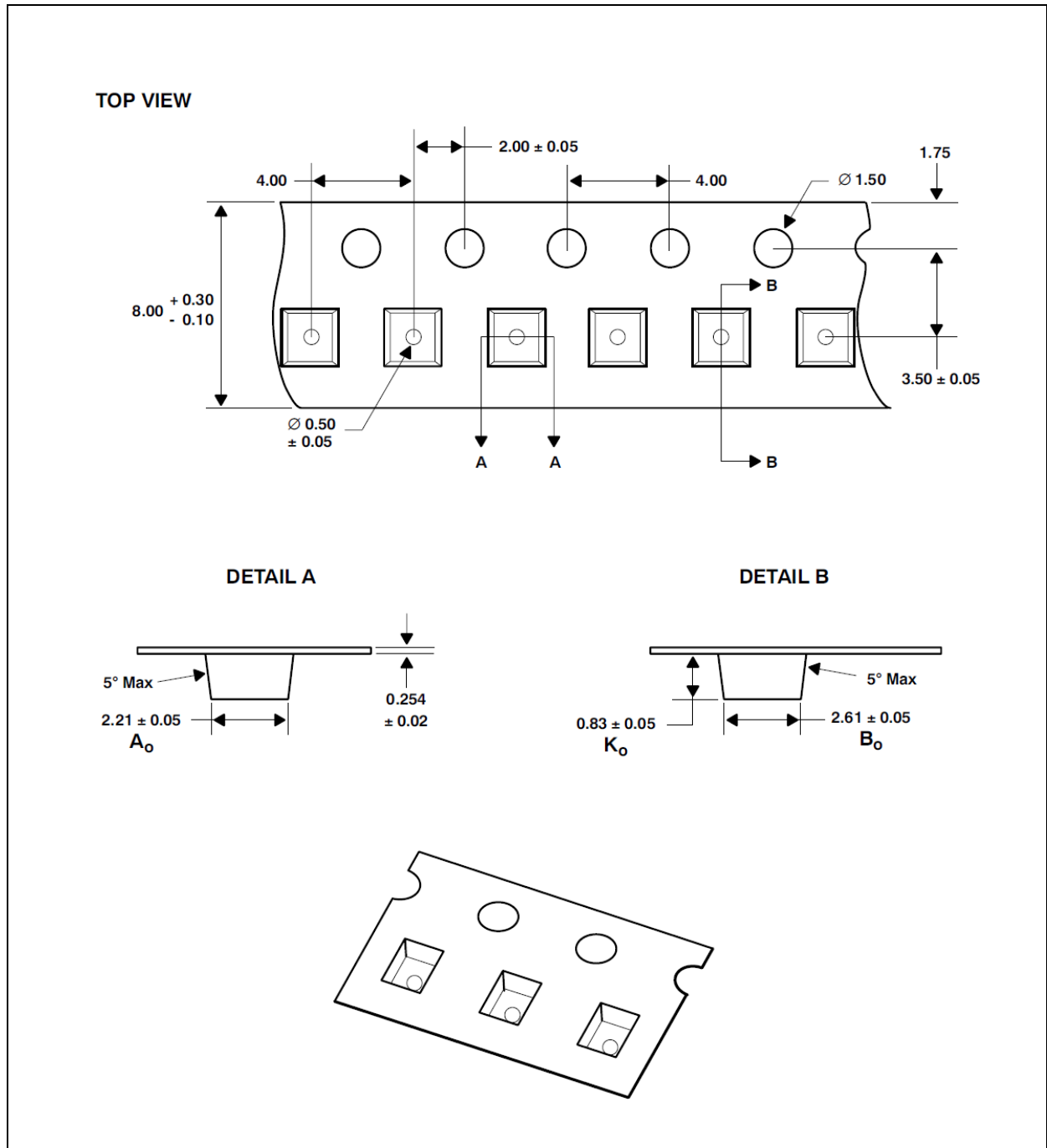

**Note(s):**

1. All linear dimensions are in millimeters. Dimension tolerance is  $\pm 0.10$  mm unless otherwise noted.
2. The dimensions on this drawing are for illustrative purposes only. Dimensions of an actual carrier may vary slightly.
3. Symbols on drawing  $A_0$ ,  $B_0$ , and  $K_0$  are defined in ANSI EIA Standard 481-B 2001.
4. Each reel is 178 millimeters in diameter and contains 3500 parts.
5. **ams** packaging tape and reel conform to the requirements of EIA Standard 481-B.
6. In accordance with EIA standard, device pin 1 is located next to sprocket holes in the tape.
7. This drawing is subject to change without notice.

## Soldering and Storage Information

### Soldering Information

The FN package has been tested and has demonstrated an ability to be reflow soldered to a PCB substrate.

The solder reflow profile describes the expected maximum heat exposure of components during the solder reflow process of product on a PCB. Temperature is measured on top of component. The components should be limited to a maximum of three passes through this solder reflow profile.

**Figure 52:**  
Solder Reflow Profile

Parameter	Reference	Device
Average temperature gradient in preheating		2.5°C/s
Soak time	$t_{soak}$	2 to 3 minutes
Time above 217°C ( $T_1$ )	$t_1$	Max 60 s
Time above 230°C ( $T_2$ )	$t_2$	Max 50 s
Time above $T_{peak} - 10^\circ\text{C}$ ( $T_3$ )	$t_3$	Max 10 s
Peak temperature in reflow	$T_{peak}$	260°C
Temperature gradient in cooling		Max -5°C/s

**Figure 53:**  
Solder Reflow Profile Graph

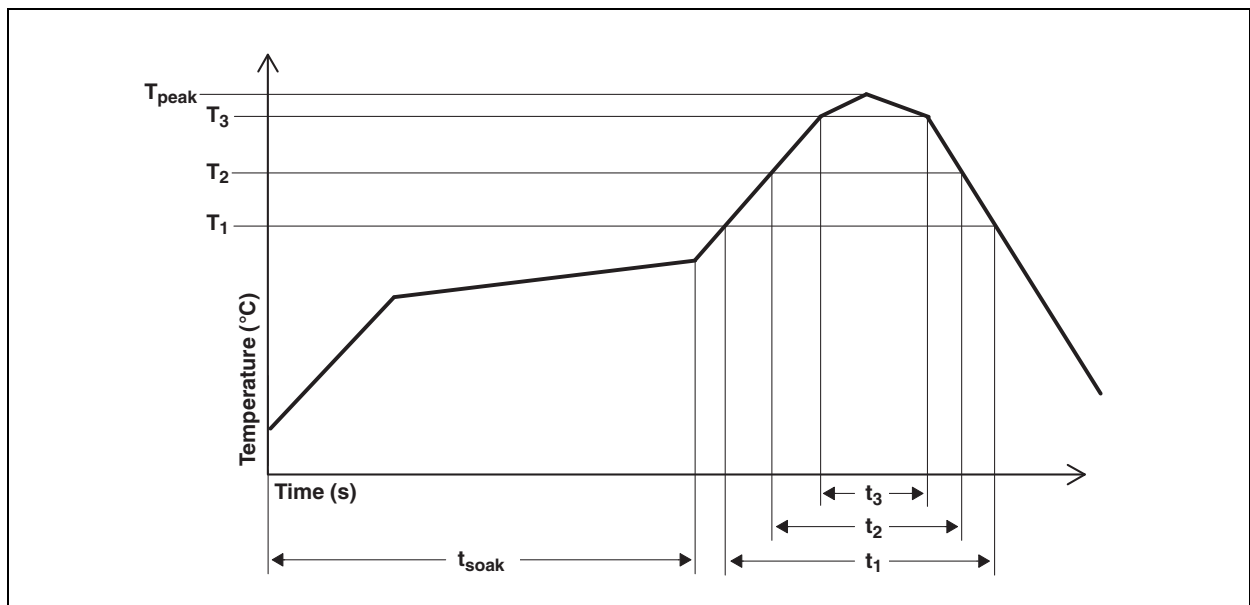

**Note(s):**

1. Not to scale – for reference only.

## Storage Information

### **Moisture Sensitivity**

Optical characteristics of the device can be adversely affected during the soldering process by the release and vaporization of moisture that has been previously absorbed into the package. To ensure the package contains the smallest amount of absorbed moisture possible, each device is baked prior to being dry packed for shipping. Devices are dry packed in a sealed aluminized envelope called a moisture-barrier bag with silica gel to protect them from ambient moisture during shipping, handling, and storage before use.

### **Shelf Life**

The calculated shelf life of the device in an unopened moisture barrier bag is 12 months from the date code on the bag when stored under the following conditions:

- Shelf Life: 12 months
- Ambient Temperature: < 40°C
- Relative Humidity: < 90%

Rebaking of the devices will be required if the devices exceed the 12 month shelf life or the Humidity Indicator Card shows that the devices were exposed to conditions beyond the allowable moisture region.

### **Floor Life**

The FN package has been assigned a moisture sensitivity level of MSL 3. As a result, the floor life of devices removed from the moisture barrier bag is 168 hours from the time the bag was opened, provided that the devices are stored under the following conditions:

- Floor Life: 168 hours
- Ambient Temperature: < 30°C
- Relative Humidity: < 60%

If the floor life or the temperature/humidity conditions have been exceeded, the devices must be rebaked prior to solder reflow or dry packing.

### **Rebaking Instructions**

When the shelf life or floor life limits have been exceeded, rebake at 50°C for 12 hours.

## Ordering & Contact Information

Figure 54:  
Ordering Information

Ordering Code	Device	Address	Package-Leads	Interface Description
TCS37725FN	TCS37725 <sup>(1)</sup>	0x29	FN-6	I <sup>2</sup> C V <sub>BUS</sub> = V <sub>DD</sub> Interface
TCS37727FN	TCS37727	0x29	FN-6	I <sup>2</sup> C V <sub>BUS</sub> = 1.8 V Interface

**Note(s):**

1. Contact **ams** for availability.

Buy our products or get free samples online at:

[www.ams.com/ICdirect](http://www.ams.com/ICdirect)

Technical Support is available at:

[www.ams.com/Technical-Support](http://www.ams.com/Technical-Support)

Provide feedback about this document at:

[www.ams.com/Document-Feedback](http://www.ams.com/Document-Feedback)

For further information and requests, e-mail us at:

[ams\\_sales@ams.com](mailto:ams_sales@ams.com)

For sales offices, distributors and representatives, please visit:

[www.ams.com/contact](http://www.ams.com/contact)

**Headquarters**

ams AG

Tobelbader Strasse 30

8141 Premstaetten

Austria, Europe

Tel: +43 (0) 3136 500 0

Website: [www.ams.com](http://www.ams.com)

## RoHS Compliant & ams Green Statement

**RoHS:** The term RoHS compliant means that ams AG products fully comply with current RoHS directives. Our semiconductor products do not contain any chemicals for all 6 substance categories, including the requirement that lead not exceed 0.1% by weight in homogeneous materials. Where designed to be soldered at high temperatures, RoHS compliant products are suitable for use in specified lead-free processes.

**ams Green (RoHS compliant and no Sb/Br):** ams Green defines that in addition to RoHS compliance, our products are free of Bromine (Br) and Antimony (Sb) based flame retardants (Br or Sb do not exceed 0.1% by weight in homogeneous material).

**Important Information:** The information provided in this statement represents ams AG knowledge and belief as of the date that it is provided. ams AG bases its knowledge and belief on information provided by third parties, and makes no representation or warranty as to the accuracy of such information. Efforts are underway to better integrate information from third parties. ams AG has taken and continues to take reasonable steps to provide representative and accurate information but may not have conducted destructive testing or chemical analysis on incoming materials and chemicals. ams AG and ams AG suppliers consider certain information to be proprietary, and thus CAS numbers and other limited information may not be available for release.

## Copyrights & Disclaimer

Copyright ams AG, Tobelbader Strasse 30, 8141 Premstaetten, Austria-Europe. Trademarks Registered. All rights reserved. The material herein may not be reproduced, adapted, merged, translated, stored, or used without the prior written consent of the copyright owner.

Devices sold by ams AG are covered by the warranty and patent indemnification provisions appearing in its General Terms of Trade. ams AG makes no warranty, express, statutory, implied, or by description regarding the information set forth herein. ams AG reserves the right to change specifications and prices at any time and without notice. Therefore, prior to designing this product into a system, it is necessary to check with ams AG for current information. This product is intended for use in commercial applications. Applications requiring extended temperature range, unusual environmental requirements, or high reliability applications, such as military, medical life-support or life-sustaining equipment are specifically not recommended without additional processing by ams AG for each application. This product is provided by ams AG "AS IS" and any express or implied warranties, including, but not limited to the implied warranties of merchantability and fitness for a particular purpose are disclaimed.

ams AG shall not be liable to recipient or any third party for any damages, including but not limited to personal injury, property damage, loss of profits, loss of use, interruption of business or indirect, special, incidental or consequential damages, of any kind, in connection with or arising out of the furnishing, performance or use of the technical data herein. No obligation or liability to recipient or any third party shall arise or flow out of ams AG rendering of technical or other services.

## Document Status

Document Status	Product Status	Definition
Product Preview	Pre-Development	Information in this datasheet is based on product ideas in the planning phase of development. All specifications are design goals without any warranty and are subject to change without notice
Preliminary Datasheet	Pre-Production	Information in this datasheet is based on products in the design, validation or qualification phase of development. The performance and parameters shown in this document are preliminary without any warranty and are subject to change without notice
Datasheet	Production	Information in this datasheet is based on products in ramp-up to full production or full production which conform to specifications in accordance with the terms of ams AG standard warranty as given in the General Terms of Trade
Datasheet (discontinued)	Discontinued	Information in this datasheet is based on products which conform to specifications in accordance with the terms of ams AG standard warranty as given in the General Terms of Trade, but these products have been superseded and should not be used for new designs

## Revision Information

Changes from 1-00 (2016-Aug-22) to current revision 1-01 (2018-Mar-14)	Page
Updated Figure 6 and 7	6
Updated Figure 43	35
Updated Figure 54	44

**Note(s):**

1. Page and figure numbers for the previous version may differ from page and figure numbers in the current revision.
2. Correction of typographical errors is not explicitly mentioned.



## Content Guide

<b>1</b>	<b>General Description</b>
1	Key Benefits & Features
2	Applications
2	End Products and Market Segments
3	Block Diagram
<b>4</b>	<b>Pin Assignment</b>
<b>5</b>	<b>Absolute Maximum Ratings</b>
<b>6</b>	<b>Electrical Characteristics</b>
<b>10</b>	<b>Timing Characteristics</b>
<b>10</b>	<b>Timing Diagrams</b>
<b>11</b>	<b>Typical Operating Characteristics</b>
<b>15</b>	<b>Detailed Description</b>
<b>16</b>	<b>Principles of Operation</b>
16	System State Machine
17	RGBC Operation
18	Proximity Detection
20	Interrupts
21	System Timing
23	Power Management
<b>24</b>	<b>I<sup>2</sup>C Protocol</b>
<b>25</b>	<b>Register Description</b>
27	Command Register
28	Enable Register (0x00)
29	RGBC Time Register (0x01)
29	Proximity Time Register (0x02)
30	Wait Time Register (0x03)
31	Clear Interrupt Threshold Registers (0x04 - 0x07)
31	Proximity Interrupt Threshold Registers (0x08 - 0x0B)
32	Persistence Filter Register (0x0C)
33	Configuration Register (0x0D)
34	Proximity Pulse Count Register (0x0E)
34	Control Register (0x0F)
35	ID Register (0x12)
35	Status Register (0x13)
36	RGBC Channel Data Registers (0x14 - 0x1B)
36	Proximity Data Registers (0x1C - 0x1D)
<b>37</b>	<b>Application Information: Hardware</b>
37	LED Driver Pin with Proximity Detection
39	PCB Pad Layout
<b>40</b>	<b>Package Drawings &amp; Markings</b>
<b>41</b>	<b>Carrier Tape &amp; Reel Information</b>
<b>42</b>	<b>Soldering and Storage Information</b>
42	Soldering Information
43	Storage Information
43	Moisture Sensitivity

- 43 Shelf Life
- 43 Floor Life
- 43 Rebaking Instructions

- 44 Ordering & Contact Information**
- 45 RoHS Compliant & ams Green Statement**
- 46 Copyrights & Disclaimer**
- 47 Document Status**
- 48 Revision Information**

## Данный компонент на территории Российской Федерации

### Вы можете приобрести в компании MosChip.

Для оперативного оформления запроса Вам необходимо перейти по данной ссылке:

<http://moschip.ru/get-element>

Вы можете разместить у нас заказ для любого Вашего проекта, будь то серийное производство или разработка единичного прибора.

В нашем ассортименте представлены ведущие мировые производители активных и пассивных электронных компонентов.

Нашей специализацией является поставка электронной компонентной базы двойного назначения, продукции таких производителей как XILINX, Intel (ex.ALTERA), Vicor, Microchip, Texas Instruments, Analog Devices, Mini-Circuits, Amphenol, Glenair.

Сотрудничество с глобальными дистрибьюторами электронных компонентов, предоставляет возможность заказывать и получать с международных складов практически любой перечень компонентов в оптимальные для Вас сроки.

На всех этапах разработки и производства наши партнеры могут получить квалифицированную поддержку опытных инженеров.

Система менеджмента качества компании отвечает требованиям в соответствии с ГОСТ Р ИСО 9001, ГОСТ РВ 0015-002 и ЭС РД 009

### Офис по работе с юридическими лицами:

105318, г.Москва, ул.Щербаковская д.3, офис 1107, 1118, ДЦ «Щербаковский»

Телефон: +7 495 668-12-70 (многоканальный)

Факс: +7 495 668-12-70 (доб.304)

E-mail: [info@moschip.ru](mailto:info@moschip.ru)

Skype отдела продаж:

moschip.ru

moschip.ru\_4

moschip.ru\_6

moschip.ru\_9