

**DLP-RFID-
LP8C**
LEAD-FREE

8-Channel Reader/Writer

FEATURES:

- ISO 15693, 18000-3, 14443*, Tag-it™ HF-I Compatible
- Can read the UID/SID of up to 15 Tags Simultaneously
- 13.56MHz Reader/Writer
- 8 Channels for External Antenna Connections
- FCC/IC/CE Modular Approvals in Place
- USB Port Powered from Windows, CE or Linux PC
- Both USB and RS232 Interfaces Provided
- USB Interface; No Driver Development Required for Windows, CE or Linux PC
- Operating Temperatures: 0°C to 70°C
- Dimensions: (L x W x H) 4.36" x 3.32" x 0.6"

APPLICATIONS INCLUDE:

- Real-Time Security
- Personal Identification
- Pharmaceutical Tracking
- Inventory/Asset Management & Tracking
- Library/Book Management & Tracking
- Baggage Tagging
- Sports Event Timing

1.0 INTRODUCTION

The DLP-RFID-LP8C is a low-cost, USB-powered module for reading from and writing to ISO 15693, ISO 18000-3, ISO14443* and Tag-it™ intelligent RFID transponder tags via up to eight external antennas. It has the ability to both read and write up to 256 bytes of data in addition to reading the unique identifier (UID/SID). All of the DLP-RFID-LP8C's electronics reside on a single, compact PCB; and all operational power is taken from the host Windows/Windows CE/Linux PC via the USB interface. Up to eight external antennas can be connected via standard SMA connectors.

* - Contact DLP Design for ISO14443 implementation information.

2.0 APPLICATION DEVELOPMENT

Demonstration source code written in Visual C++ is provided with the purchase of a DLP-RFID-LP8C module that demonstrates the communications protocol. Using the Virtual COM Port USB drivers, the DLP-RFID-LP8C appears to the host PC (Windows, Linux, Mac) as an RS232 port.

3.0 MECHANICAL DIMENSIONS IN INCHES (MM)

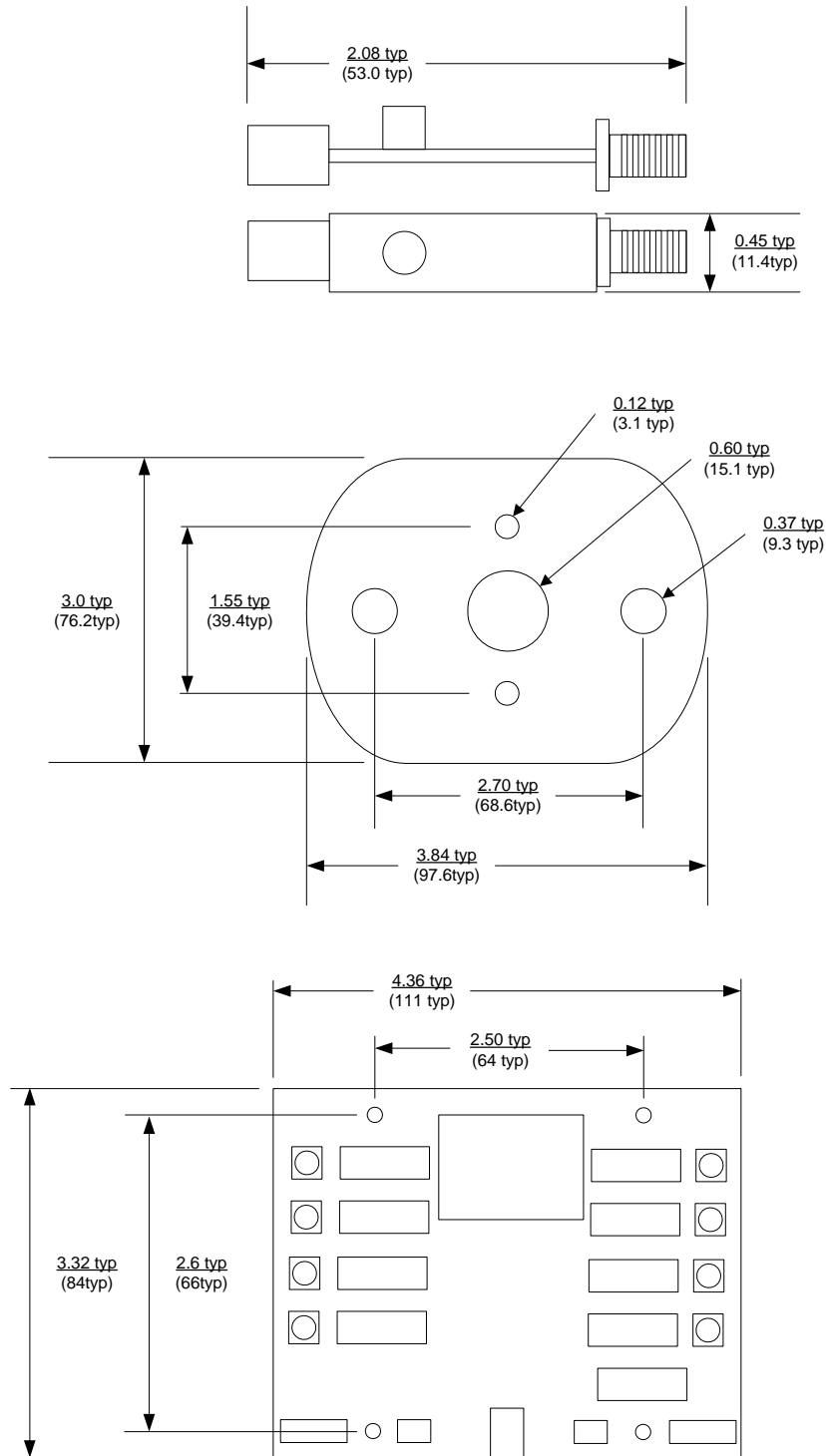

4.0 REGULATORY AGENCY CONSIDERATIONS

4.1 AGENCY IDENTIFICATION NUMBERS

Compliance with the appropriate regulatory agencies is essential in the deployment of all intentional radiators. DLP Design has obtained modular approval for this RF product such that an OEM need only meet a few basic requirements in order to utilize their end product under this approval. Corresponding agency identification numbers are listed below:

<u>PART NUMBER</u>	<u>US/FCC</u>	<u>CAN/IC</u>
DLP-RFID-LP8C	SX90LP8C	5675A-0LP8C

4.2 EXTERNAL ANTENNAS

The DLP-RFID1-LP8C is approved for use with selected external antennas. Connection is made via reverse-polarity SMA connectors.

Two different antennas are available from DLP Design: the **DLP-FANT** and the **DLP-RFID-ANT**.



DLP-FANT



DLP-RFID-ANT

The DLP-FANT ferrite-based antenna provides a compact footprint for space-constrained applications and provides up to a 1.25-inch read range.

The DLP-FANT requires a coax cable with a reverse-polarity SMA connector at one end for connection to the DLP-RFID-LP8C reader. This coax cable is available in a 3-foot length from DLP Design under part number DLP-COAX1.

The DLP-RFID-ANT ships with an attached 15-foot coax cable with a reverse-polarity SMA connector and provides up to 4 inches of read range.

4.3 FCC/IC REQUIREMENTS FOR MODULAR APPROVAL

Any changes or modifications to the DLP-RFID-LP8C's printed circuit board could void the user's authority to operate the equipment. Operation of an unapproved antenna could void the user's authority to operate the equipment.

4.4 WARNINGS

Operation is subject to the following two conditions: (1) This device may not cause harmful interference; and (2) this device must accept any interference received, including interference that may cause undesirable operation.

To reduce potential radio interference with other users, the antenna type and its gain should be so chosen that the equivalent isotropically-radiated power (e.i.r.p.) is not more than that permitted for successful communication.

This device is intended for use under the following conditions:

1. The transmitter module may not be co-located with any other transmitter or antenna; and,
2. The module is approved using the FCC "unlicensed modular transmitter approval" method.

As long as these two conditions are met, further transmitter testing will not be required. However, the OEM integrator is still responsible for testing their end product for any additional compliance measures necessitated by the installation of this module (i.e. digital device emissions, PC peripheral requirements, etc.).

Note: In the event that these conditions cannot be met (i.e. co-location with another transmitter), then the FCC authorization is no longer valid, and the corresponding FCC ID may *not* be used on the final product. Under these circumstances, the OEM integrator will be responsible for re-evaluating the end product (including the transmitter) and obtaining a separate FCC authorization.

4.5 OEM PRODUCT LABELING

The final end product must be labeled in a visible area with the following text:

"Contains TX FCC ID: SX90LP8C"

4.6 RF EXPOSURE

In order to comply with FCC RF exposure-compliance requirements, the antenna used for this transmitter must not be co-located or operating in conjunction with any other antenna or transmitter.

4.7 ADDITIONAL INFORMATION FOR OEM INTEGRATORS

The end user should NOT be provided with any instructions on how to remove or install the DLP-RFID-LP8C. This device has been pre-certified to operate with the antenna models listed below:

- DLP Design Large Loop Antenna
- DLP Design Small Loop Antenna
- DLP Design Ferrite Antenna

5.0 DISCLAIMER

Neither the whole nor any part of the information contained herein nor the product described in this datasheet may be adapted or reproduced in any material or electronic form without the prior written consent of the copyright holder.

This product and its documentation are supplied on an as-is basis, and no warranty as to their suitability for any particular purpose is either made or implied. DLP Design will not accept any claim for damages whatsoever arising as a result of use or failure of this product. Your statutory rights are not affected.

This product or any variant of it is not intended for use in any medical appliance, device or system in which the failure of the product might reasonably be expected to result in personal injury.

This document provides preliminary information that may be subject to change without notice.

6.0 CONTACT INFORMATION

DLP Design, Inc.
1605 Roma Lane
Allen, TX 75013

Phone: 469-964-8027
Fax: 415-901-4859
Email: support@dlpdesign.com
Internet: <http://www.dlpdesign.com>

Данный компонент на территории Российской Федерации

Вы можете приобрести в компании MosChip.

Для оперативного оформления запроса Вам необходимо перейти по данной ссылке:

<http://moschip.ru/get-element>

Вы можете разместить у нас заказ для любого Вашего проекта, будь то серийное производство или разработка единичного прибора.

В нашем ассортименте представлены ведущие мировые производители активных и пассивных электронных компонентов.

Нашей специализацией является поставка электронной компонентной базы двойного назначения, продукции таких производителей как XILINX, Intel (ex.ALTERA), Vicor, Microchip, Texas Instruments, Analog Devices, Mini-Circuits, Amphenol, Glenair.

Сотрудничество с глобальными дистрибьюторами электронных компонентов, предоставляет возможность заказывать и получать с международных складов практически любой перечень компонентов в оптимальные для Вас сроки.

На всех этапах разработки и производства наши партнеры могут получить квалифицированную поддержку опытных инженеров.

Система менеджмента качества компании отвечает требованиям в соответствии с ГОСТ Р ИСО 9001, ГОСТ РВ 0015-002 и ЭС РД 009

Офис по работе с юридическими лицами:

105318, г.Москва, ул.Щербаковская д.3, офис 1107, 1118, ДЦ «Щербаковский»

Телефон: +7 495 668-12-70 (многоканальный)

Факс: +7 495 668-12-70 (доб.304)

E-mail: info@moschip.ru

Skype отдела продаж:

moschip.ru

moschip.ru_4

moschip.ru_6

moschip.ru_9