

MEMS audio sensor omnidirectional digital microphone

Datasheet - production data

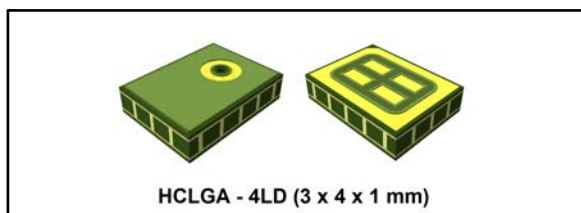

Features

- Single supply voltage
- Low power consumption
- AOP = 122.5 dB SPL
- 64 dB signal-to-noise ratio
- Omnidirectional sensitivity
- -26 dBFS \pm 3 dB sensitivity
- PDM output
- HCLGA package
 - Top-port design
 - SMD-compliant
 - EMI-shielded
 - ECOPACK[®], RoHS, and "Green" compliant

Applications

- Mobile terminals
- Laptop and notebook computers
- Portable media players
- VoIP
- Speech recognition
- A/V eLearning devices
- Gaming and virtual reality input devices
- Digital still and video cameras
- Antitheft systems

Description

The MP34DT05-A is an ultra-compact, low-power, omnidirectional, digital MEMS microphone built with a capacitive sensing element and an IC interface.

The sensing element, capable of detecting acoustic waves, is manufactured using a specialized silicon micromachining process dedicated to producing audio sensors.

The IC interface is manufactured using a CMOS process that allows designing a dedicated circuit able to provide a digital signal externally in PDM format.

The MP34DT05-A is a low-distortion digital microphone with a 64 dB signal-to-noise ratio and -26 dBFS \pm 3 dB sensitivity.

The MP34DT05-A is available in a top-port, SMD-compliant, EMI-shielded package and is guaranteed to operate over an extended temperature range from -40 °C to +85 °C.

Table 1: Device summary

Order codes	Temp. range [°C]	Package	Packing
MP34DT05TR-A	-40 to +85	HCLGA (3 x 4 x 1 mm) 4LD	Tape and reel

Contents

1 Pin description 5

2 Acoustic and electrical specifications 6

 2.1 Acoustic and electrical characteristics..... 6

 2.2 Timing characteristics 7

 2.3 Frequency response 8

3 Application recommendations 9

4 Carrier tape mechanical specifications 10

5 Process recommendations 11

6 Sensing element 13

7 Absolute maximum ratings..... 14

8 Functionality 15

 8.1 L/R channel selection..... 15

9 Package information 16

 9.1 Soldering information 16

 9.2 HCLGA package information..... 17

10 Revision history 19



List of tables

Table 1: Device summary	1
Table 2: Pin description	5
Table 3: Acoustic and electrical characteristics	6
Table 4: Distortion specifications @ 1 kHz	6
Table 5: Timing characteristics	7
Table 6: Absolute maximum ratings	14
Table 7: L/R channel selection	15
Table 8: Recommended soldering profile limits.....	16
Table 9: Document revision history	19

List of figures

Figure 1: Pin connections	5
Figure 2: Timing waveforms	7
Figure 3: Typical frequency response normalized to 1 kHz.....	8
Figure 4: MP34DT05-A electrical connections (top view).....	9
Figure 5: MP34DT05-A electrical connections for stereo configuration (top view).....	9
Figure 6: Carrier tape without microphone (top view).....	10
Figure 7: Carrier tape with microphone (top view).....	10
Figure 8: Recommended picking area.....	11
Figure 9: Recommended picker design	12
Figure 10: Recommended soldering profile limits	16
Figure 11: HCLGA (3 x 4 x 1 mm) 4-lead package outline and mechanical data	17
Figure 12: Land pattern.....	18

1 Pin description

Figure 1: Pin connections

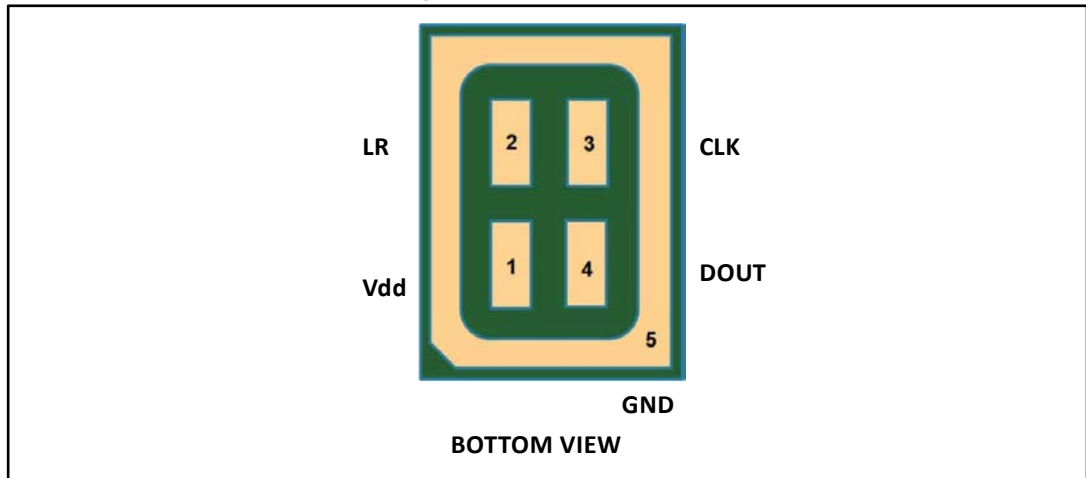

Table 2: Pin description

Pin #	Pin name	Function
1	Vdd	Power supply
2	LR	Left/Right channel selection
3	CLK	Synchronization input clock
4	DOUT	Left/Right PDM data output
5 (ground ring)	GND	Ground

2 Acoustic and electrical specifications

2.1 Acoustic and electrical characteristics

The values listed in the table below are specified for $V_{dd} = 1.8\text{ V}$, Clock = 2.4 MHz, $T = 25\text{ }^{\circ}\text{C}$, unless otherwise noted.

Table 3: Acoustic and electrical characteristics

Symbol	Parameter	Test condition	Min.	Typ. ⁽¹⁾	Max.	Unit
Vdd	Supply voltage		1.6	1.8	3.6	V
Idd	Current consumption in normal mode	Mean value		650		μA
IddPdn	Current consumption in power-down mode ⁽²⁾				5	μA
Sc	Short-circuit current		1		10	mA
AOP	Acoustic overload point			122.5		dB SPL
So	Sensitivity		-29	-26	-23	dBFS
SNR	Signal-to-noise ratio	A-weighted @ 1 kHz, 94 dB SPL		64		dB(A)
PSR	Power supply rejection	100 mVpp sine 1 kHz			-90	dBFS
f _{CLK}	Input clock frequency ⁽³⁾		1.2	2.4	3.25	MHz
T _{on}	Turn-on time ⁽⁴⁾	Guaranteed by design			10	ms
T _{op}	Operating temperature range		-40		+85	$^{\circ}\text{C}$
V _{IOL}	Low-level logic input/output voltage	$I_{out} = 1\text{ mA}$	-0.3		$0.35 \times V_{dd}$	V
V _{IOH}	High-level logic input/output voltage	$I_{out} = 1\text{ mA}$	$0.65 \times V_{dd}$		$V_{dd} + 0.3$	V
C _{LOAD}	Capacitive load				100	pF

Notes:

⁽¹⁾Typical specifications are not guaranteed.

⁽²⁾Input clock in static mode.

⁽³⁾Duty cycle: min = 40% max = 60%.

⁽⁴⁾Time from the first clock edge to valid output data.

Table 4: Distortion specifications @ 1 kHz

Parameter	Test condition	Typical value ⁽¹⁾
Distortion	94 dB SPL	0.2% THD + N
Distortion	110 dB SPL	0.7% THD + N
Distortion	120 dB SPL	6% THD + N

Notes:

⁽¹⁾Typical specifications are not guaranteed.

2.2 Timing characteristics

Table 5: Timing characteristics

Parameter	Description	Min.	Max.	Unit
f_{CLK}	Clock frequency for normal mode	1.2	3.25	MHz
f_{PD}	Clock frequency for power-down mode		0.23	MHz
T_{CLK}	Clock period for normal mode	308	1000	ns
$T_{R,EN}$	Data enabled on DATA line, L/R pin = 1	70	90	ns
$T_{R,DIS}$	Data disabled on DATA line, L/R pin = 1	4.3	5.3	ns
$T_{L,EN}$	Data enabled on DATA line, L/R pin = 0	64	87	ns
$T_{L,DIS}$	Data disabled on DATA line, L/R pin = 0	3.5	4.3	ns

Figure 2: Timing waveforms

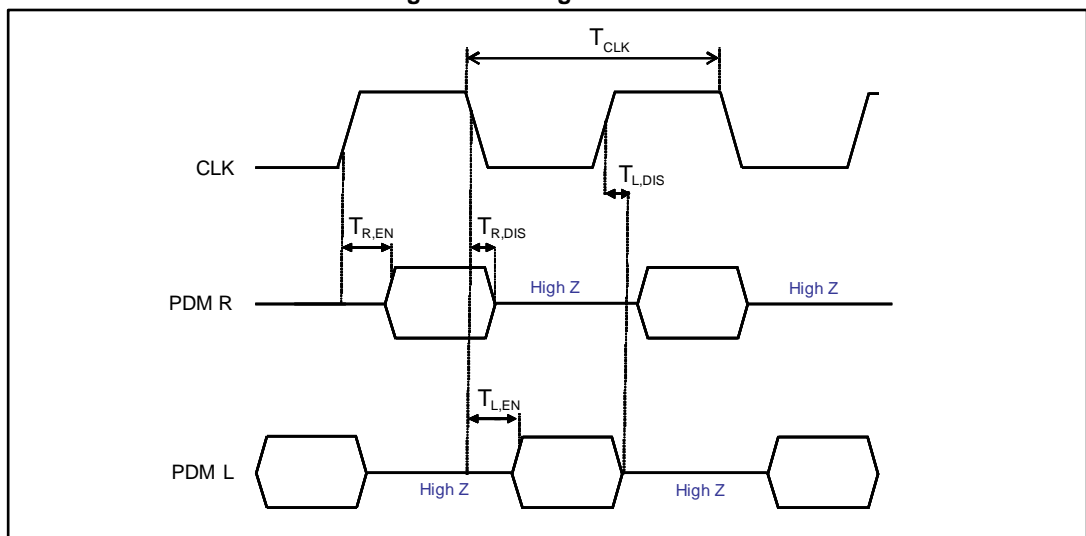

2.3 Frequency response

Figure 3: Typical frequency response normalized to 1 kHz

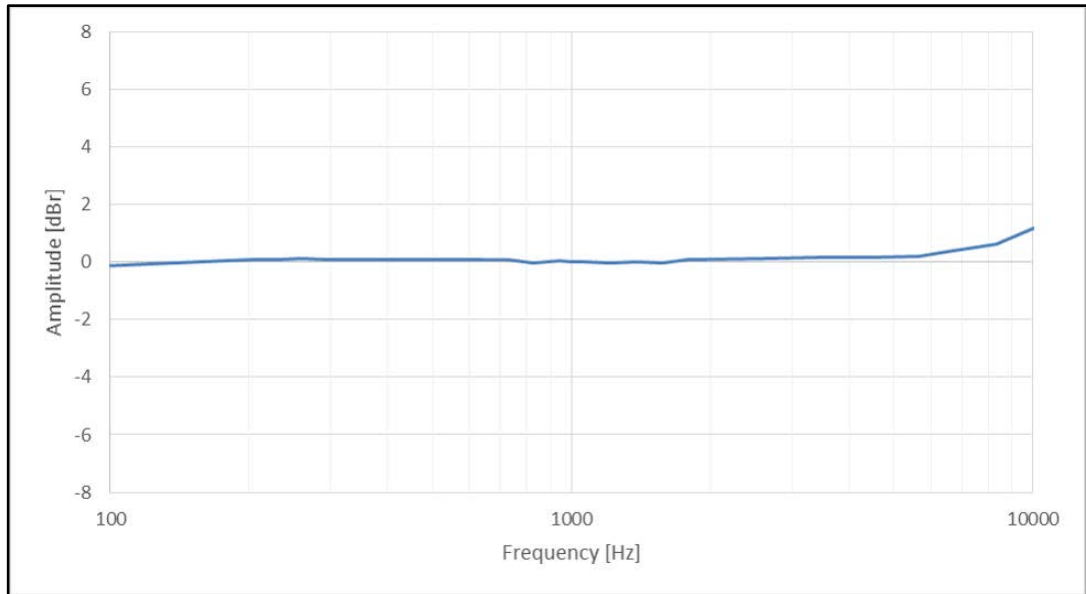

3 Application recommendations

Figure 4: MP34DT05-A electrical connections (top view)

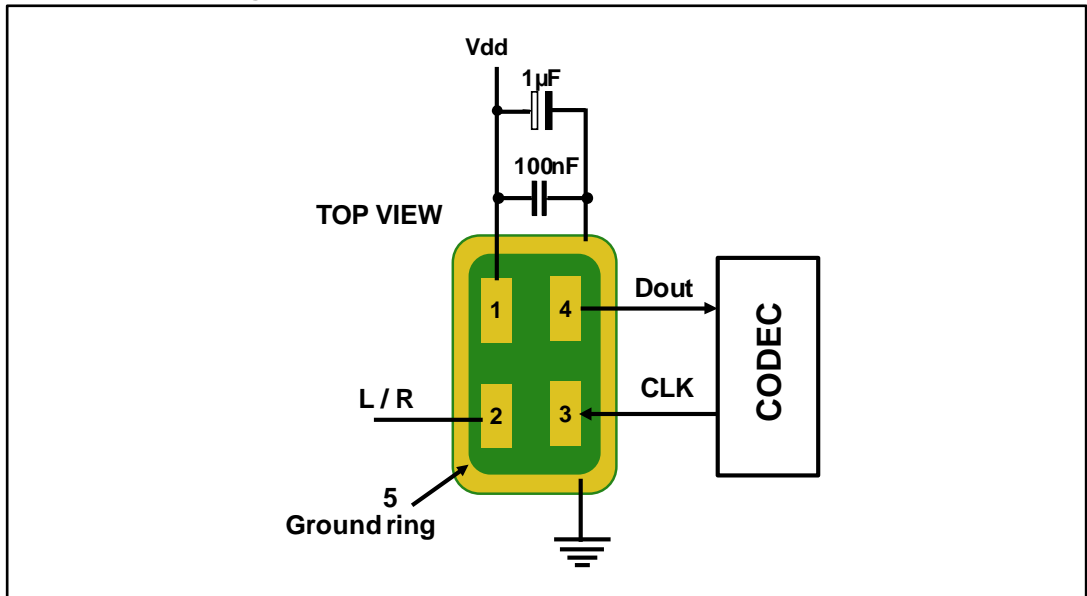
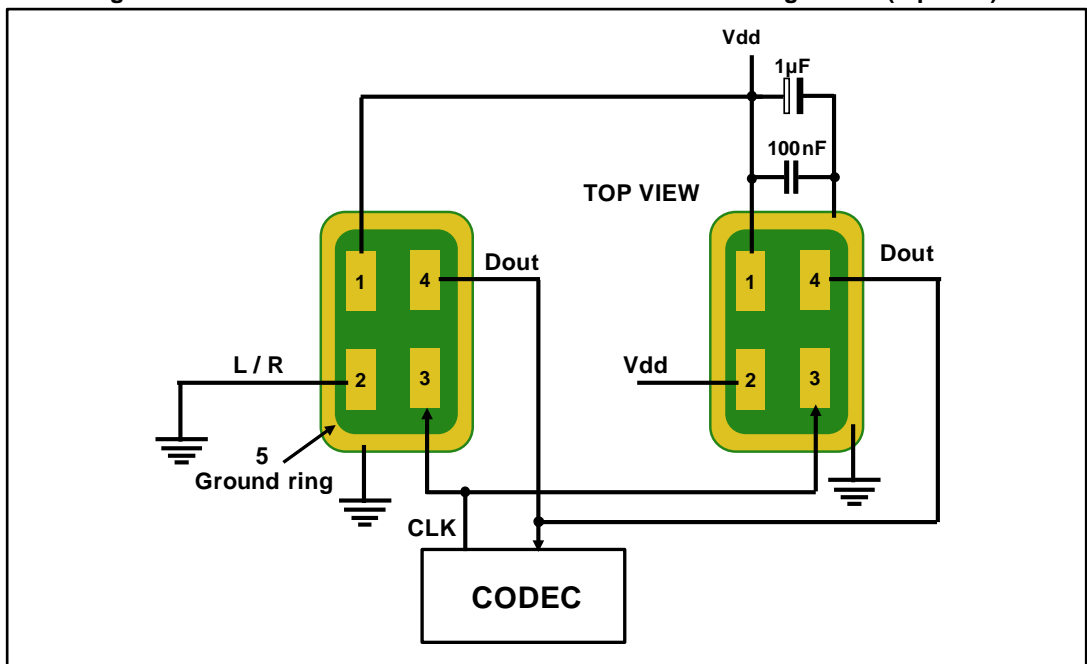

Figure 5: MP34DT05-A electrical connections for stereo configuration (top view)



Power supply decoupling capacitors (100 nF ceramic, 1 µF ceramic) should be placed as near as possible to pin 1 of the device (common design practice).

The L/R pin must be connected to Vdd or GND (refer to [Table 7: "L/R channel selection"](#)).

4 Carrier tape mechanical specifications

Figure 6: Carrier tape without microphone (top view)

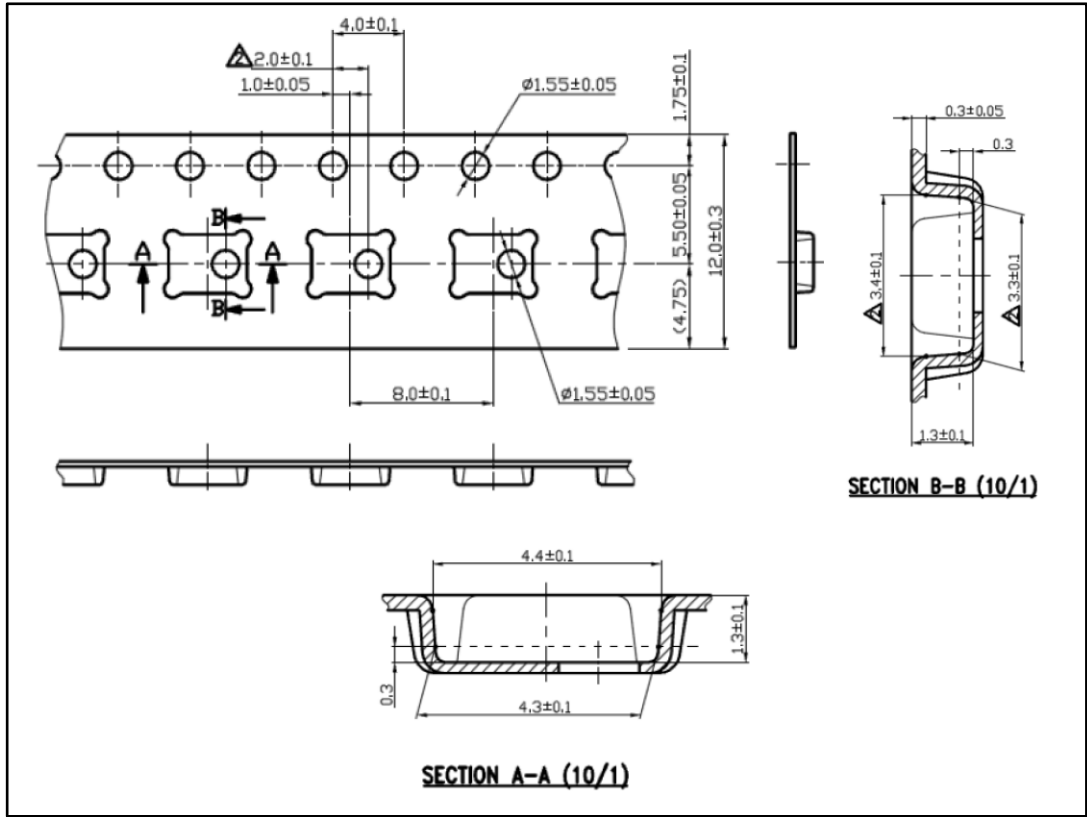
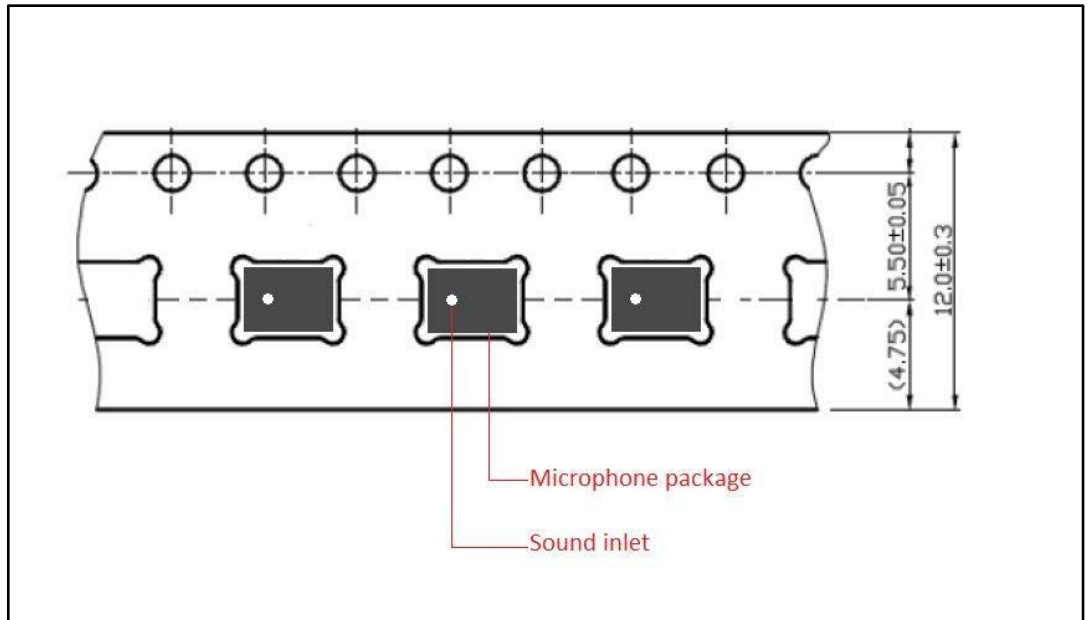

Figure 7: Carrier tape with microphone (top view)



5 Process recommendations

To ensure a consistent manufacturing process it is strongly advised to comply with following recommendations:

- The recommended pick-up area for the MP34DT05 package must be defined using the worst case (ie. no device alignment during picking process). This area has been defined considering all the tolerances of the components involved (reel, package, sound inlet). Picker tolerance shall be considered as well.
- To prevent damage to the MEMS membrane or incorrect pick-up and placement, do not pick up the component on the inlet area
- For the package outline please refer to [Figure 7: "Carrier tape with microphone \(top view\)"](#). Nozzle shape, size, and placement accuracy are the other key factors to consider when deciding on the coordinates for the picking.
- Device alignment before picking is highly recommended.
- A vacuum force greater than 7 psi must be avoided
- $1 \text{ kPa} = 0.145 \text{ psi (lb/in}^2\text{)} = 0.0102 \text{ kgf/cm}^2 = 0.0098 \text{ atm}$
- MSL (moisture sensitivity level) Class 3
- Maximum of 3 reflow cycles is recommended
- All recommended dimensions (device safe-picking area) do not include the pick-and-place equipment tolerances

Figure 8: Recommended picking area

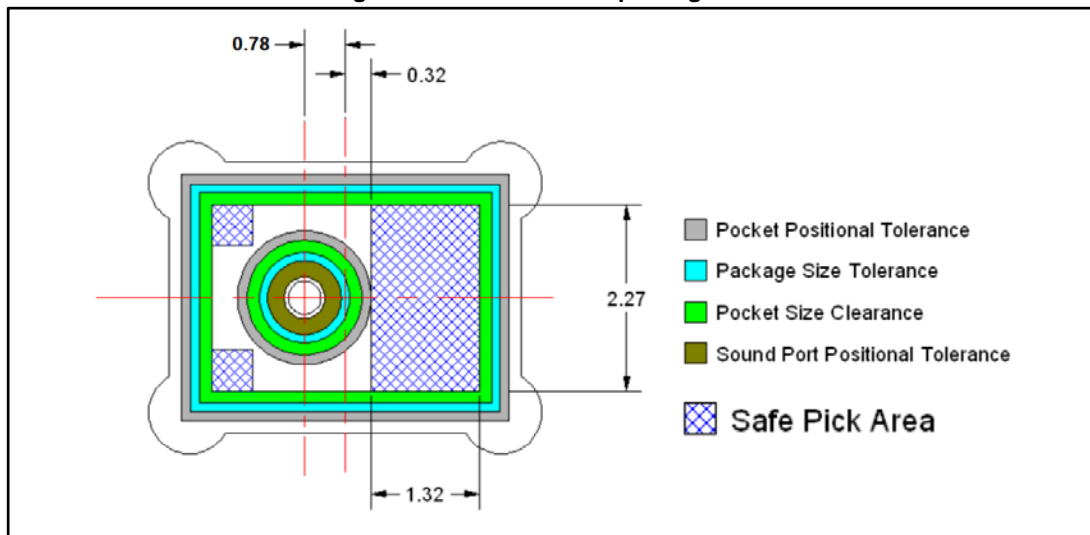

To have a safe pick-up "by design", ST strongly advises an ad hoc nozzle.

The following picker ensures that the holes for the vacuum and the air stream are ALWAYS away from the porthole of the device (4 vacuum ports located at each corner of the device).

The recommended nozzle also has a recess, in the form of a cross, which guarantees that the porthole is always left at atmospheric pressure. By using the recommended nozzle, the membrane will not suffer any sudden air disturbances during the picking or placing of the devices in the tape and reel.

Figure 9: Recommended picker design

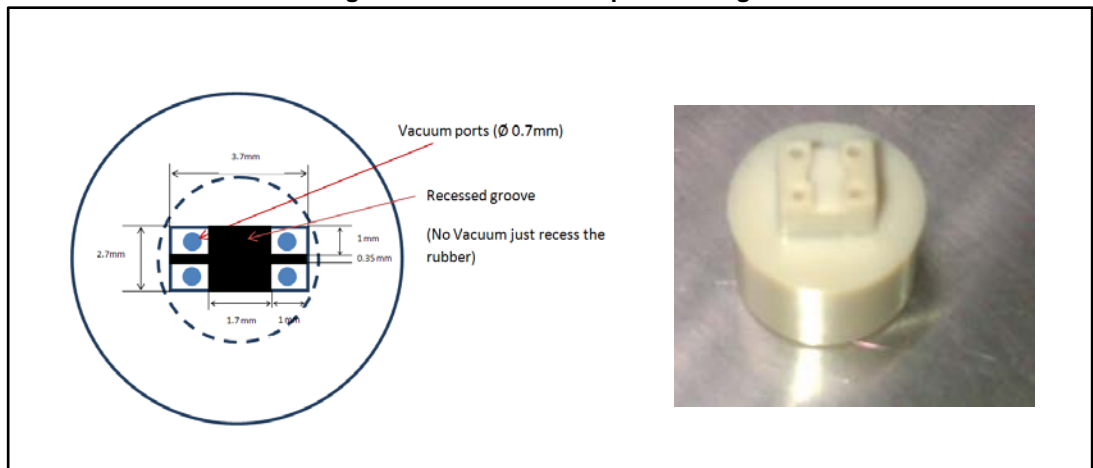

6 Sensing element

The sensing element shall mean the acoustic sensor consisting of a conductive movable plate and a fixed plate placed in a tiny silicon chip. This sensor transduces the sound pressure into the changes of coupled capacity between those two plates.

7 Absolute maximum ratings

Stresses above those listed as “absolute maximum ratings” may cause permanent damage to the device. This is a stress rating only and functional operation of the device under these conditions is not implied. Exposure to maximum rating conditions for extended periods may affect device reliability.

Table 6: Absolute maximum ratings

Symbol	Ratings	Maximum value	Unit
V _{dd}	Supply voltage	-0.3 to 5	V
V _{in}	Input voltage on any control pin	-0.3 to V _{dd} +0.3	V
T _{STG}	Storage temperature range	-40 to +125	°C
ESD	Electrostatic discharge protection	±2000 (HBM)	V
		±200 (MM)	
		±750 (CBM)	
ESD	Product standard EN 55024:2010 - 3 air discharge	±15000	V



This device is sensitive to mechanical shock, improper handling can cause permanent damage to the part.



This device is sensitive to electrostatic discharge (ESD), improper handling can cause permanent damage to the part.

8 Functionality

8.1 L/R channel selection

The L/R digital pad lets the user select the DOUT signal pattern as shown in [Table 7: "L/R channel selection"](#). The L/R pin must be connected to Vdd or GND.

Table 7: L/R channel selection

L/R	CLK low	CLK high
GND	Data valid	High impedance
Vdd	High impedance	Data valid

Note: As the L/R pin is internally connected to GND via a 200 kohm pull/down resistor, it is not mandatory to connect the pin itself to GND for the respective channel selection.

9 Package information

In order to meet environmental requirements, ST offers these devices in different grades of ECOPACK® packages, depending on their level of environmental compliance. ECOPACK® specifications, grade definitions and product status are available at: www.st.com. ECOPACK® is an ST trademark.

9.1 Soldering information

The HCLGA (3 x 4) 4LD package is also compliant with the RoHS and “Green” standards and is qualified for soldering heat resistance according to JEDEC J-STD-020.

Land pattern and soldering recommendations are available at www.st.com.

Figure 10: Recommended soldering profile limits

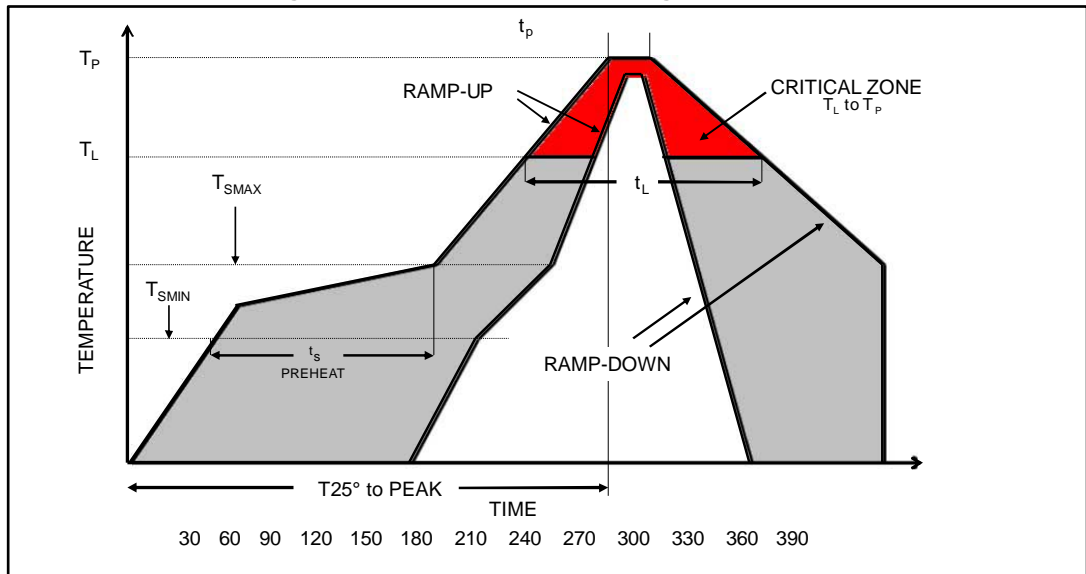
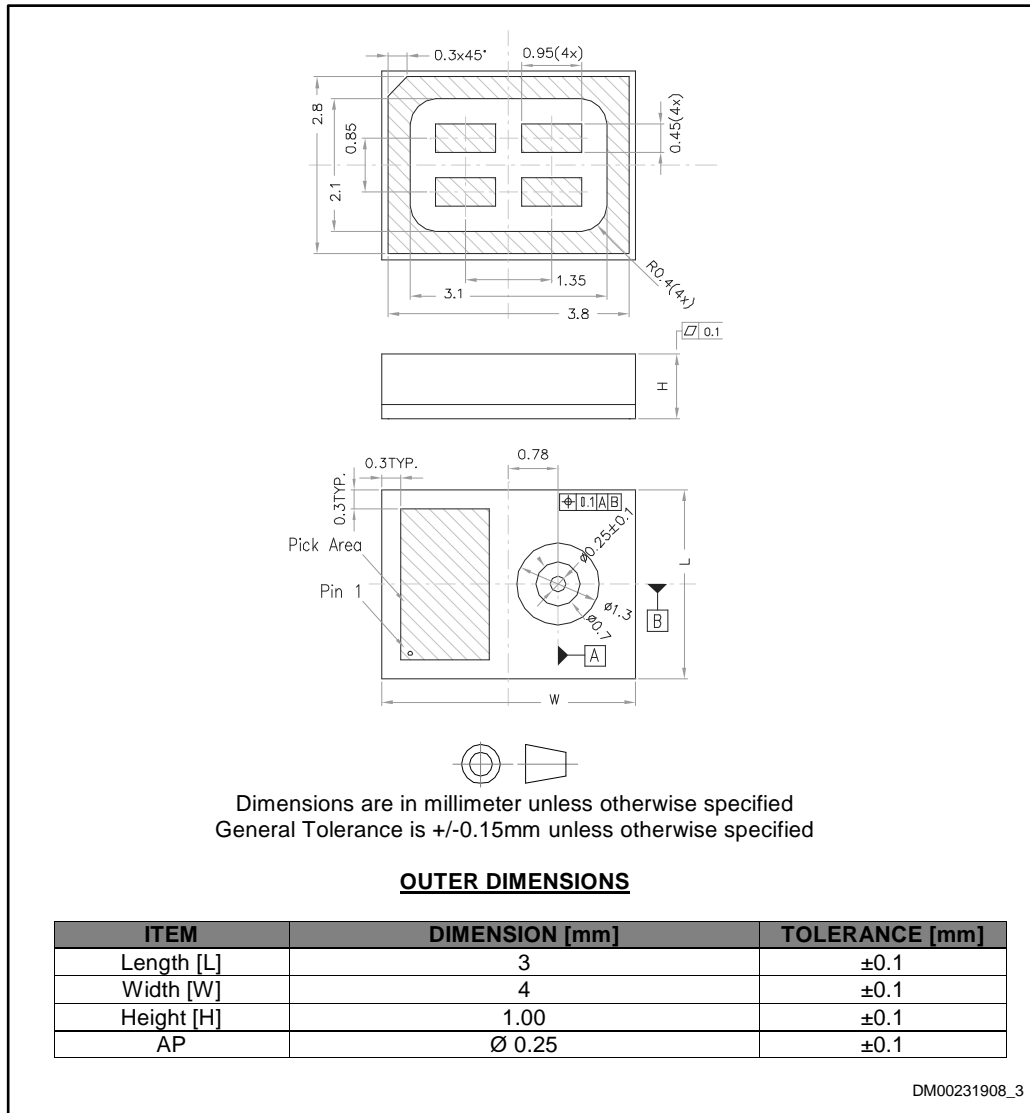

Table 8: Recommended soldering profile limits

Description	Parameter	Pb free
Average ramp rate	T_L to T_P	3 °C/sec max
Preheat		
Minimum temperature	T_{SMIN}	150 °C
Maximum temperature	T_{SMAX}	200 °C
Time (T_{SMIN} to T_{SMAX})	t_s	60 sec to 120 sec
Ramp-up rate	T_{SMAX} to T_L	
Time maintained above liquids temperature	t_L	60 sec to 150 sec
Liquids temperature	T_L	217 °C
Peak temperature	T_P	260 °C max
Time within 5 °C of actual peak temperature		20 sec to 40 sec
Ramp-down rate		6 °C/sec max
Time 25 °C (t_{25} °C) to peak temperature		8 minutes max

9.2 HCLGA package information

Figure 11: HCLGA (3 x 4 x 1 mm) 4-lead package outline and mechanical data



1. The MEMS microphone plastic cap can exhibit some level of variation in color when the device is subjected to thermal processes. This variation does not affect acoustic or electrical performance.
2. Ring plating can be subject to change not affecting acoustic and electrical performance.

Figure 12: Land pattern

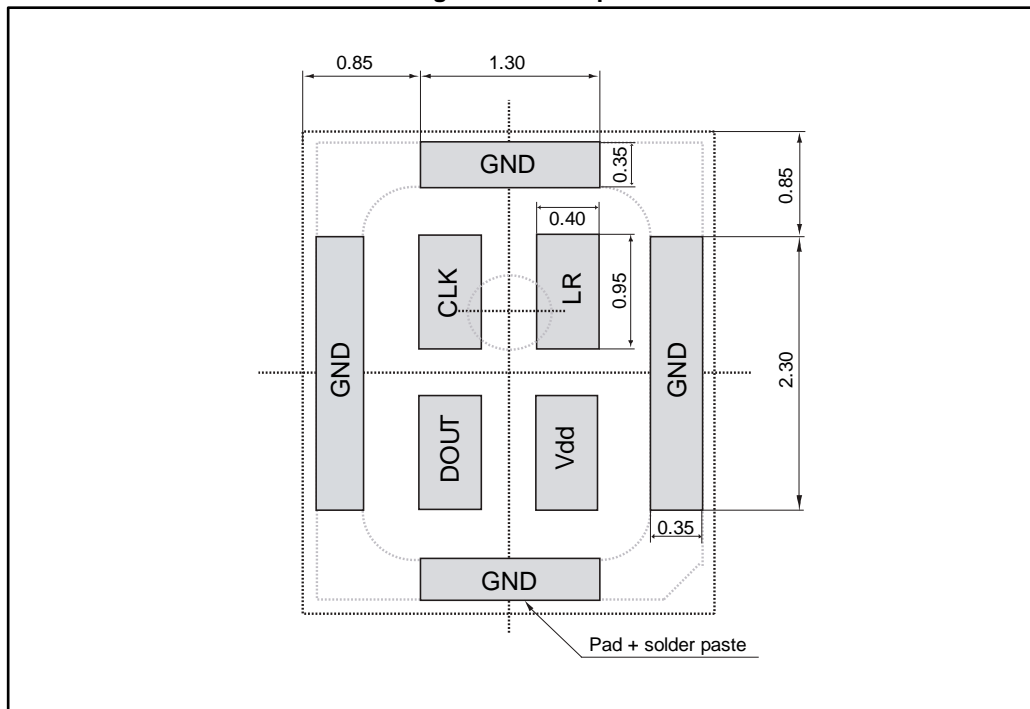

10 Revision history

Table 9: Document revision history

Date	Revision	Changes
24-Jul-2017	1	Initial release
21-Sep-2017	2	Updated Section 6: "Sensing element"
13-Dec-2017	3	Document status promoted to "production data"

IMPORTANT NOTICE – PLEASE READ CAREFULLY

STMicroelectronics NV and its subsidiaries ("ST") reserve the right to make changes, corrections, enhancements, modifications, and improvements to ST products and/or to this document at any time without notice. Purchasers should obtain the latest relevant information on ST products before placing orders. ST products are sold pursuant to ST's terms and conditions of sale in place at the time of order acknowledgement.

Purchasers are solely responsible for the choice, selection, and use of ST products and ST assumes no liability for application assistance or the design of Purchasers' products.

No license, express or implied, to any intellectual property right is granted by ST herein.

Resale of ST products with provisions different from the information set forth herein shall void any warranty granted by ST for such product.

ST and the ST logo are trademarks of ST. All other product or service names are the property of their respective owners.

Information in this document supersedes and replaces information previously supplied in any prior versions of this document.

© 2017 STMicroelectronics – All rights reserved

Данный компонент на территории Российской Федерации

Вы можете приобрести в компании MosChip.

Для оперативного оформления запроса Вам необходимо перейти по данной ссылке:

<http://moschip.ru/get-element>

Вы можете разместить у нас заказ для любого Вашего проекта, будь то серийное производство или разработка единичного прибора.

В нашем ассортименте представлены ведущие мировые производители активных и пассивных электронных компонентов.

Нашей специализацией является поставка электронной компонентной базы двойного назначения, продукции таких производителей как XILINX, Intel (ex.ALTERA), Vicor, Microchip, Texas Instruments, Analog Devices, Mini-Circuits, Amphenol, Glenair.

Сотрудничество с глобальными дистрибьюторами электронных компонентов, предоставляет возможность заказывать и получать с международных складов практически любой перечень компонентов в оптимальные для Вас сроки.

На всех этапах разработки и производства наши партнеры могут получить квалифицированную поддержку опытных инженеров.

Система менеджмента качества компании отвечает требованиям в соответствии с ГОСТ Р ИСО 9001, ГОСТ РВ 0015-002 и ЭС РД 009

Офис по работе с юридическими лицами:

105318, г.Москва, ул.Щербаковская д.3, офис 1107, 1118, ДЦ «Щербаковский»

Телефон: +7 495 668-12-70 (многоканальный)

Факс: +7 495 668-12-70 (доб.304)

E-mail: info@moschip.ru

Skype отдела продаж:

moschip.ru

moschip.ru_4

moschip.ru_6

moschip.ru_9