

## ADC with Microphone Input and Programmable Digital Filters

### DESCRIPTION

The WM8950 is a low power, high quality mono ADC designed for portable applications such as Digital Still Camera, Digital Voice Recorder or games console accessories.

The device integrates support for a differential or single ended mic. External component requirements are reduced as no separate microphone amplifiers are required.

Advanced Sigma Delta Converters are used along with digital decimation filters to give high quality audio at sample rates from 8 to 48ks/s. Additional digital filtering options are available, to cater for application filtering such as wind noise reduction, noise rejection, plus an advanced mixed signal ALC function with noise gate is provided.

An on-chip PLL is provided to generate the required Master Clock from an external reference clock. The PLL clock can also be output if required elsewhere in the system.

The WM8950 operates at supply voltages from 2.5 to 3.6V, although the digital supplies can operate at voltages down to 1.71V to save power. Different sections of the chip can also be powered down under software control by way of the selectable two or three wire control interface.

WM8950 is supplied in a very small 4x4mm QFN package, offering high levels of functionality in minimum board area, with high thermal performance.

### FEATURES

#### Mono ADC:

- Audio sample rates: 8, 11.025, 16, 22.05, 24, 32, 44.1, 48kHz
- SNR 94dB, THD -83dB ('A'-weighted @ 8 – 48ks/s)
- Multiple auxiliary analogue inputs

#### Mic Preamps:

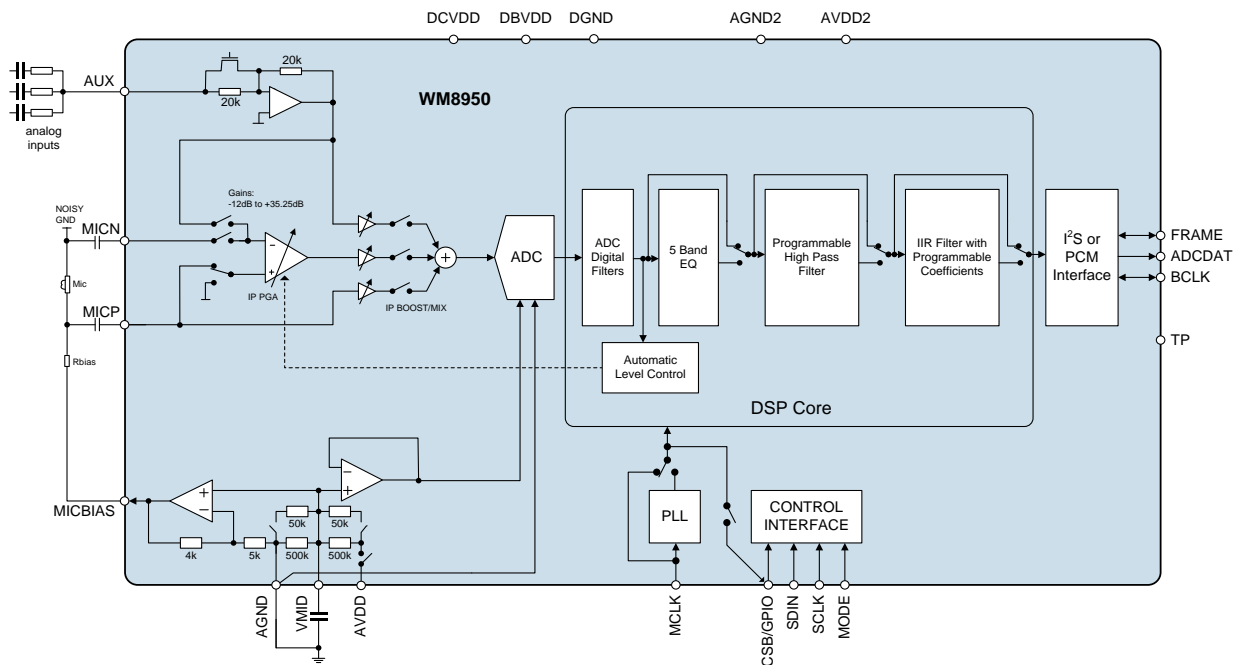
- Differential or single end Microphone Interface
  - Programmable preamp gain
  - Pseudo differential inputs with common mode rejection
  - Programmable ALC / Noise Gate in ADC path
- Low-noise bias supplied for electret microphones

#### OTHER FEATURES

- 5 band EQ
- Programmable High-Pass Filter (wind noise reduction)
- Fully Programmable IIR Filter (notch filter)
- On-chip PLL
- Low power, low voltage
  - 2.5V to 3.6V (digital: 1.71V to 3.6V)
  - power consumption 10mA all-on 48ks/s mode
- 4x4x0.9mm 24 lead QFN package

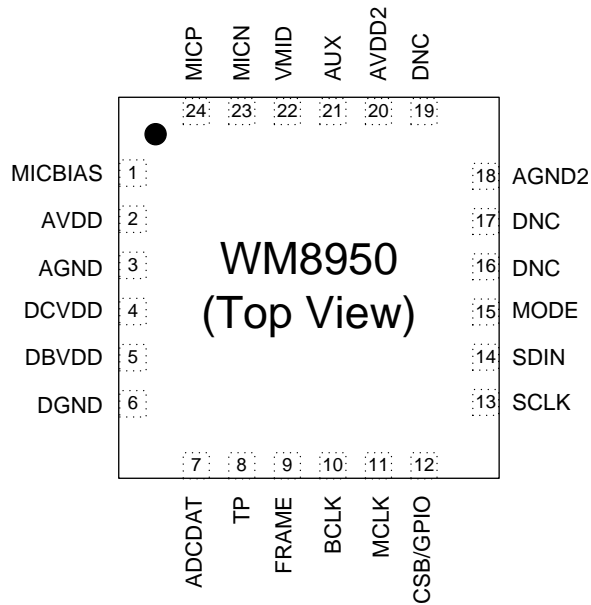
### APPLICATIONS

- Digital Still Camera
- General Purpose low power audio ADC
- Games console accessories
- Voice recorders



**TABLE OF CONTENTS**

<b>DESCRIPTION</b> .....	<b>1</b>
<b>FEATURES</b> .....	<b>1</b>
<b>APPLICATIONS</b> .....	<b>1</b>
<b>TABLE OF CONTENTS</b> .....	<b>2</b>
<b>PIN CONFIGURATION</b> .....	<b>3</b>
<b>ORDERING INFORMATION</b> .....	<b>3</b>
<b>PIN DESCRIPTION</b> .....	<b>4</b>
<b>ABSOLUTE MAXIMUM RATINGS</b> .....	<b>5</b>
<b>RECOMMENDED OPERATING CONDITIONS</b> .....	<b>5</b>
<b>ELECTRICAL CHARACTERISTICS</b> .....	<b>6</b>
TERMINOLOGY.....	7
<b>SIGNAL TIMING REQUIREMENTS</b> .....	<b>8</b>
SYSTEM CLOCK TIMING.....	8
AUDIO INTERFACE TIMING – MASTER MODE .....	8
AUDIO INTERFACE TIMING – SLAVE MODE.....	9
CONTROL INTERFACE TIMING – 3-WIRE MODE.....	10
CONTROL INTERFACE TIMING – 2-WIRE MODE.....	11
<b>DEVICE DESCRIPTION</b> .....	<b>12</b>
INTRODUCTION.....	12
INPUT SIGNAL PATH.....	13
ANALOGUE TO DIGITAL CONVERTER (ADC).....	18
INPUT AUTOMATIC LEVEL CONTROL (ALC) .....	22
DIGITAL AUDIO INTERFACES .....	36
AUDIO SAMPLE RATES.....	41
MASTER CLOCK AND PHASE LOCKED LOOP (PLL).....	42
GENERAL PURPOSE INPUT/OUTPUT .....	44
CONTROL INTERFACE.....	44
RESETTING THE CHIP .....	45
POWER SUPPLIES .....	46
ADC POWER UP/DOWN SEQUENCE.....	46
POWER MANAGEMENT .....	47
<b>REGISTER MAP</b> .....	<b>49</b>
<b>DIGITAL FILTER CHARACTERISTICS</b> .....	<b>50</b>
TERMINOLOGY.....	50
ADC FILTER RESPONSES .....	50
DE-EMPHASIS FILTER RESPONSES.....	51
HIGH-PASS FILTER .....	52
5-BAND EQUALISER.....	53
<b>APPLICATIONS INFORMATION</b> .....	<b>57</b>
RECOMMENDED EXTERNAL COMPONENTS.....	57
<b>PACKAGE DIAGRAM</b> .....	<b>58</b>
<b>IMPORTANT NOTICE</b> .....	<b>59</b>
<b>REVISION HISTORY</b> .....	<b>60</b>

**PIN CONFIGURATION**

**ORDERING INFORMATION**

ORDER CODE	TEMPERATURE RANGE	PACKAGE	MOISTURE SENSITIVITY LEVEL	PACKAGE BODY TEMPERATURE
WM8950CGEFL/V	-40°C to +85°C	24-lead QFN (4x4x0.9mm) (Pb-free)	MSL3	260°C
WM8950CGEFL/RV	-40°C to +85°C	24-lead QFN (4x4x0.9mm) (Pb-free, tape and reel)	MSL3	260°C

**Note:**

Reel Quantity = 3,500

**PIN DESCRIPTION**

PIN NO	NAME	TYPE	DESCRIPTION
1	MICBIAS	Analogue Output	Microphone bias
2	AVDD	Supply	Analogue supply (feeds ADC)
3	AGND	Supply	Analogue ground (feeds ADC)
4	DCVDD	Supply	Digital core supply
5	DBVDD	Supply	Digital buffer (input/output) supply
6	DGND	Supply	Digital ground
7	ADCDAT	Digital Output	ADC digital audio data output
8	TP	Test Pin	Connect to ground
9	FRAME	Digital Input / Output	ADC sample rate clock or frame synch
10	BCLK	Digital Input / Output	Digital audio bit clock
11	MCLK	Digital Input	Master clock input
12	CSB/GPIO	Digital Input / Output	3-Wire MPU chip select or general purpose input/output pin.
13	SCLK	Digital Input	3-Wire MPU clock Input / 2-Wire MPU Clock Input
14	SDIN	Digital Input / Output	3-Wire MPU data Input / 2-Wire MPU Data Input
15	MODE	Digital Input	Control interface mode selection pin.
16	DNC	Do not connect	Leave this pin floating
17	DNC	Do not connect	Leave this pin floating
18	AGND2	Supply	Analogue ground
19	DNC	Do not connect	Leave this pin floating
20	AVDD2	Supply	Analogue supply
21	AUX	Analogue Input	Auxiliary analogue input
22	VMID	Reference	Decoupling for midrail reference voltage
23	MICN	Analogue Input	Microphone negative input
24	MICP	Analogue Input	Microphone positive input (common mode)

**Note:**

It is recommended that the QFN ground paddle should be connected to analogue ground on the application PCB.

## ABSOLUTE MAXIMUM RATINGS

Absolute Maximum Ratings are stress ratings only. Permanent damage to the device may be caused by continuously operating at or beyond these limits. Device functional operating limits and guaranteed performance specifications are given under Electrical Characteristics at the test conditions specified.



ESD Sensitive Device. This device is manufactured on a CMOS process. It is therefore generically susceptible to damage from excessive static voltages. Proper ESD precautions must be taken during handling and storage of this device.

Cirrus Logic tests its package types according to IPC/JEDEC J-STD-020B for Moisture Sensitivity to determine acceptable storage conditions prior to surface mount assembly. These levels are:

MSL1 = unlimited floor life at <30°C / 85% Relative Humidity. Not normally stored in moisture barrier bag.

MSL2 = out of bag storage for 1 year at <30°C / 60% Relative Humidity. Supplied in moisture barrier bag.

MSL3 = out of bag storage for 168 hours at <30°C / 60% Relative Humidity. Supplied in moisture barrier bag.

The Moisture Sensitivity Level for each package type is specified in Ordering Information.

CONDITION	MIN	MAX
DBVDD, DCVDD, AVDD, AVDD2 supply voltages	-0.3V	+4.2
Voltage range digital inputs	DGND -0.3V	DVDD +0.3V
Voltage range analogue inputs	AGND -0.3V	AVDD +0.3V
Operating temperature range, T <sub>A</sub>	-40°C	+85°C
Storage temperature prior to soldering	30°C max / 85% RH max	
Storage temperature after soldering	-65°C	+150°C

### Notes:

1. Analogue and digital grounds must always be within 0.3V of each other.
2. All digital and analogue supplies are completely independent from each other.

## RECOMMENDED OPERATING CONDITIONS

PARAMETER	SYMBOL	MIN	TYP	MAX	UNIT
Digital supply range (Core)	DCVDD	1.71		3.6	V
Digital supply range (Buffer)	DBVDD	1.71		3.6	V
Analogue supplies range	AVDD, AVDD2	2.5		3.6	V
Ground	DGND, AGND, AGND2		0		V

### Notes:

1. When using PLL, DCVDD must be 1.9V or higher.
2. AVDD must be ≥ DBVDD and DCVDD.
3. DBVDD must be ≥ DCVDD.
4. When using PLL, DCVDD must be ≥ 1.9V.

**ELECTRICAL CHARACTERISTICS**
**Test Conditions**

DCVDD = 1.8V, AVDD = DBVDD = 3.3V, SPKVDD = 3.3V, T<sub>A</sub> = +25°C, 1kHz signal, f<sub>s</sub> = 48kHz, 24-bit audio data unless otherwise stated.

PARAMETER	SYMBOL	TEST CONDITIONS	MIN	TYP	MAX	UNIT
<b>Microphone Inputs (MICN, MICP)</b>						
Full-scale Input Signal Level (Note 1) – note this changes with AVDD	V <sub>INFS</sub>	PGABOOST = 0dB INPPGAVOL = 0dB		1.0 0		V <sub>rms</sub> dBV
Mic PGA equivalent input noise	At 35.25dB gain			150		uV
Input resistance	R <sub>MICIN</sub>	Gain set to 35.25dB		1.6		kΩ
Input resistance	R <sub>MICIN</sub>	Gain set to 0dB		47		kΩ
Input resistance	R <sub>MICIN</sub>	Gain set to -12dB		75		kΩ
Input resistance	R <sub>MICIP</sub>	(Constant for all gain settings)		94		kΩ
Input Capacitance	C <sub>MICIN</sub>			10		pF
<b>MIC Input Programmable Gain Amplifier (PGA)</b>						
Maximum Programmable Gain				35.25		dB
Minimum Programmable Gain				-12		dB
Programmable Gain Step Size		Guaranteed monotonic		0.75		dB
Mute Attenuation				108		dB
<b>Selectable Input Gain Boost (0/+20dB)</b>						
Gain Boost			0		20	dB
<b>Automatic Level Control (ALC)/Limiter</b>						
Target Record Level			-28.5		-6	dB
Maximum Programmable Gain				35.25		dB
Minimum Programmable Gain				-12		dB
Programmable Gain Step Size		Guaranteed Monotonic		0.75		dB
Gain Hold Time (Note 2)	t <sub>HOLD</sub>	MCLK=12.288MHz (Note 4)	0, 2.67, 5.33, 10.67, ... , 43691 (time doubles with each step)			ms
Gain Ramp-Up (Decay) Time (Note 3)	t <sub>DCY</sub>	ALCMODE=0 (ALC), MCLK=12.288MHz (Note 4)	3.3, 6.6, 13.1, ... , 3360 (time doubles with each step)			ms
		ALCMODE=1 (limiter), MCLK=12.288MHz (Note 4)	0.73, 1.45, 2.91, ... , 744 (time doubles with each step)			
Gain Ramp-Down (Attack) Time (Note 3)	t <sub>ATK</sub>	ALCMODE=0 (ALC), MCLK=12.288MHz (Note 4)	0.83, 1.66, 3.33, ... , 852 (time doubles with each step)			ms
		ALCMODE=1 (limiter), MCLK=12.288MHz (Note 4)	0.18, 0.36, 0.73, ... , 186 (time doubles with each step)			
<b>Analogue to Digital Converter (ADC)</b>						
Signal to Noise Ratio (Note 5, 6)		A-weighted, 0dB PGA gain	85	94		dB
Total Harmonic Distortion + Noise (Note 6)	THD+N	-1dBFS input 0dB PGA gain	-75	-83		dB
<b>Auxiliary Analogue Input (AUX)</b>						
Full-scale Input Signal Level (0dB) – note this changes with AVDD	V <sub>INFS</sub>			1.0 0		V <sub>rms</sub> dBV
Input Resistance	R <sub>AUXIN</sub>	AUXMODE=0		20		kΩ
Input Capacitance	C <sub>AUXIN</sub>			10		pF

**Test Conditions**

DCVDD = 1.8V, AVDD = DBVDD = 3.3V, SPKVDD = 3.3V, T<sub>A</sub> = +25°C, 1kHz signal, fs = 48kHz, 24-bit audio data unless otherwise stated.

PARAMETER	SYMBOL	TEST CONDITIONS	MIN	TYP	MAX	UNIT
<b>Microphone Bias</b>						
Bias Voltage (MBVSEL=0)	V <sub>MICBIAS</sub>			0.9 x AVDD		V
Bias Voltage (MBVSEL=1)	V <sub>MICBIAS</sub>			0.75 x AVDD		V
Bias Current Source	I <sub>MICBIAS</sub>				3	mA
Output Noise Voltage	V <sub>n</sub>	1K to 20kHz		15		nV/√Hz
<b>Digital Input / Output</b>						
Input HIGH Level	V <sub>IH</sub>		0.7 × DVDD			V
Input LOW Level	V <sub>IL</sub>				0.3 × DVDD	V
Output HIGH Level	V <sub>OH</sub>	I <sub>OL</sub> =1mA	0.9 × DVDD			V
Output LOW Level	V <sub>OL</sub>	I <sub>OH</sub> =1mA			0.1 × DVDD	V

**TERMINOLOGY**

- MICN input only in single ended microphone configuration. Maximum input signal to MIPC without distortion is -3dBV.
- Hold Time is the length of time between a signal detected being too quiet and beginning to ramp up the gain. It does not apply to ramping down the gain when the signal is too loud, which happens without a delay.
- Ramp-up and Ramp-Down times are defined as the time it takes for the PGA to change its gain by 6dB.
- All hold, ramp-up and ramp-down times scale proportionally with MCLK
- Signal-to-noise ratio (dB) – SNR is a measure of the difference in level between the full scale output and the output with no signal applied. (No Auto-zero or Automute function is employed in achieving these results).
- THD+N (dB) – THD+N is a ratio, of the rms values, of (Noise + Distortion)/Signal.

## SIGNAL TIMING REQUIREMENTS

### SYSTEM CLOCK TIMING

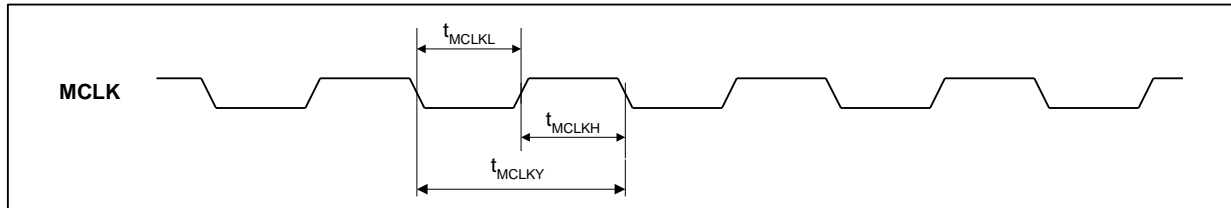


Figure 1 System Clock Timing Requirements

#### Test Conditions

DCVDD=1.8V, DBVDD=AVDD=SPKVDD=3.3V, DGND=AGND=SPKGND=0V,  $T_A = +25^\circ\text{C}$ , Slave Mode  $f_s = 48\text{kHz}$ , MCLK = 256fs, 24-bit data, unless otherwise stated.

PARAMETER	SYMBOL	CONDITIONS	MIN	TYP	MAX	UNIT
<b>System Clock Timing Information</b>						
MCLK cycle time	$T_{MCLKY}$	MCLK as direct SYSCLK source (CLKSEL=0)	81.38			ns
		MCLK as input to PLL (see note) (CLKSEL=1)	20			ns
MCLK duty cycle	$T_{MCLKDS}$		60:40		40:60	

**Note:** PLL pre-scaling and PLL N and K values should be set appropriately so that SYSCLK is no greater than 12.288MHz.

### AUDIO INTERFACE TIMING – MASTER MODE

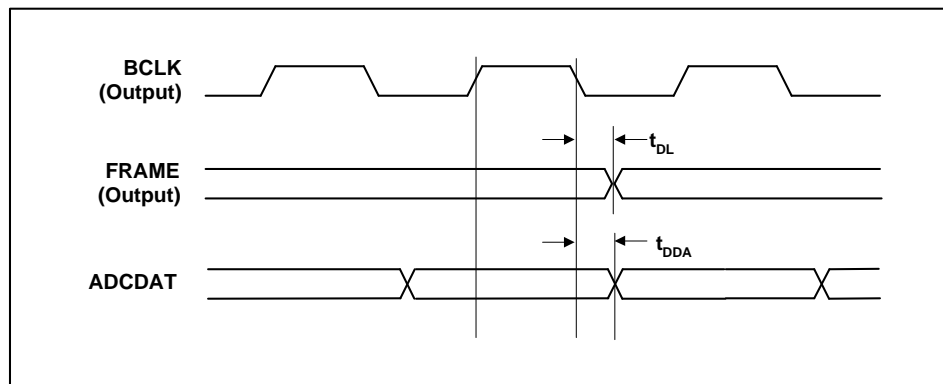


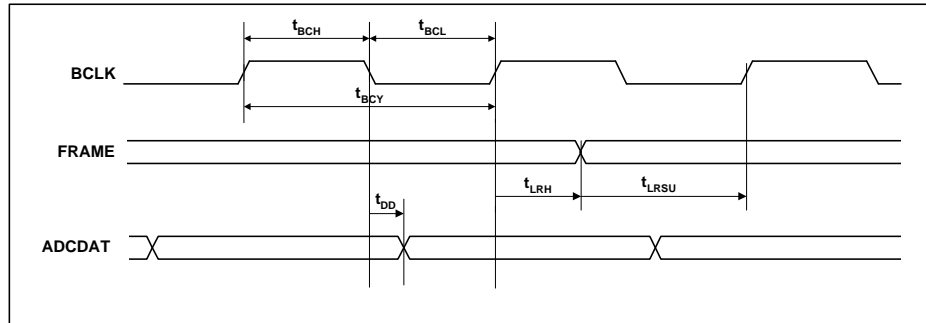
Figure 2 Digital Audio Data Timing – Master Mode (see Control Interface)

#### Test Conditions

DCVDD=1.8V, DBVDD=AVDD=SPKVDD=3.3V, DGND=AGND=SPKGND=0V,  $T_A = +25^\circ\text{C}$ , Master Mode,  $f_s=48\text{kHz}$ , MCLK=256fs, 24-bit data, unless otherwise stated.

PARAMETER	SYMBOL	MIN	TYP	MAX	UNIT
<b>Audio Data Input Timing Information</b>					
FRAME propagation delay from BCLK falling edge	$t_{DL}$			10	ns
ADCDAT propagation delay from BCLK falling edge	$t_{DDA}$			10	ns

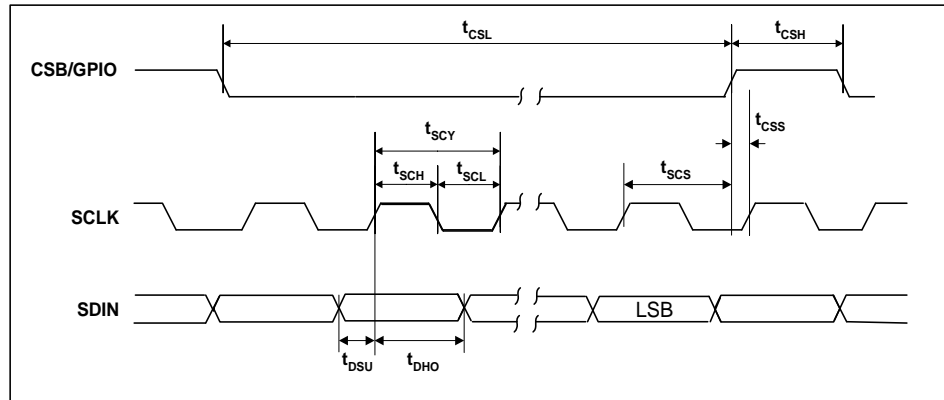


**AUDIO INTERFACE TIMING – SLAVE MODE**

**Figure 3 Digital Audio Data Timing – Slave Mode**
**Test Conditions**

DCVDD=1.8V, DBVDD=AVDD=SPKVDD=3.3V, DGND=AGND=SPKGND=0V, T<sub>A</sub>=+25°C, Slave Mode, fs=48kHz, MCLK= 256fs, 24-bit data, unless otherwise stated.

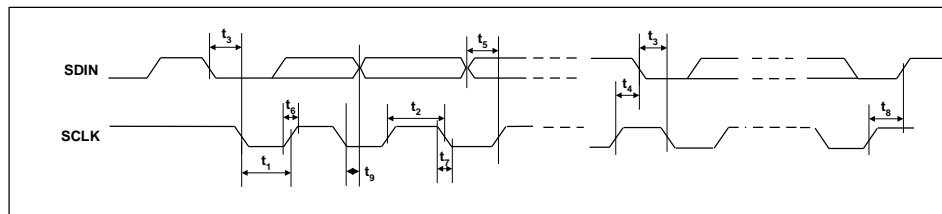
PARAMETER	SYMBOL	MIN	TYP	MAX	UNIT
<b>Audio Data Input Timing Information</b>					
BCLK cycle time	t <sub>BCY</sub>	50			ns
BCLK pulse width high	t <sub>BCH</sub>	20			ns
BCLK pulse width low	t <sub>BCL</sub>	20			ns
FRAME set-up time to BCLK rising edge	t <sub>LRSU</sub>	10			ns
FRAME hold time from BCLK rising edge	t <sub>LRH</sub>	10			ns
ADCDAT propagation delay from BCLK falling edge	t <sub>DD</sub>			20	ns

**Note:** BCLK period should always be greater than or equal to MCLK period.

**CONTROL INTERFACE TIMING – 3-WIRE MODE**

**Figure 4 Control Interface Timing – 3-Wire Serial Control Mode**
**Test Conditions**

DCVDD = 1.8V, DBVDD = AVDD = SPKVDD = 3.3V, DGND = AGND = SPKGND = 0V, T<sub>A</sub> = +25°C, Slave Mode, fs = 48kHz, MCLK = 256fs, 24-bit data, unless otherwise stated.

PARAMETER	SYMBOL	MIN	TYP	MAX	UNIT
<b>Program Register Input Information</b>					
SCLK rising edge to CSB rising edge	t <sub>SCS</sub>	80			ns
SCLK pulse cycle time	t <sub>SCY</sub>	200			ns
SCLK pulse width low	t <sub>SCL</sub>	80			ns
SCLK pulse width high	t <sub>SCH</sub>	80			ns
SDIN to SCLK set-up time	t <sub>DSU</sub>	40			ns
SCLK to SDIN hold time	t <sub>DHO</sub>	40			ns
CSB pulse width low	t <sub>CSL</sub>	40			ns
CSB pulse width high	t <sub>CSH</sub>	40			ns
CSB rising to SCLK rising	t <sub>CSS</sub>	40			ns
Pulse width of spikes that will be suppressed	t <sub>ps</sub>	0		5	ns

**CONTROL INTERFACE TIMING – 2-WIRE MODE**

**Figure 5 Control Interface Timing – 2-Wire Serial Control Mode**
**Test Conditions**

DCVDD=1.8V, DBVDD=AVDD=SPKVDD=3.3V, DGND=AGND=SPKGND=0V,  $T_A = +25^\circ\text{C}$ , Slave Mode,  $f_s = 48\text{kHz}$ , MCLK = 256fs, 24-bit data, unless otherwise stated.

PARAMETER	SYMBOL	MIN	TYP	MAX	UNIT
<b>Program Register Input Information</b>					
SCLK Frequency		0		526	kHz
SCLK Low Pulse-Width	$t_1$	1.3			us
SCLK High Pulse-Width	$t_2$	600			ns
Hold Time (Start Condition)	$t_3$	600			ns
Setup Time (Start Condition)	$t_4$	600			ns
Data Setup Time	$t_5$	100			ns
SDIN, SCLK Rise Time	$t_6$			300	ns
SDIN, SCLK Fall Time	$t_7$			300	ns
Setup Time (Stop Condition)	$t_8$	600			ns
Data Hold Time	$t_9$			900	ns
Pulse width of spikes that will be suppressed	$t_{ps}$	0		5	ns

## DEVICE DESCRIPTION

### INTRODUCTION

The WM8950 is a low power audio ADC, with flexible line and microphone input. Applications for this device include games console accessories, digital still cameras, voice recorders and other general purpose audio applications.

The chip offers great flexibility in use, and so can support many different modes of operation as follows:

#### MICROPHONE INPUTS

Microphone inputs are provided, allowing for either a differential microphone input or a single ended microphone to be connected. These inputs have a user programmable gain range of -12dB to +35.25dB using internal resistors. After the input PGA stage comes a boost stage which can add a further 20dB of gain. A microphone bias is output from the chip which can be used to bias the microphones. The signal routing can be configured to allow manual adjustment of mic levels, or to allow the ALC loop to control the level of mic signal that is transmitted.

Total gain through the microphone paths of up to +55.25dB can be selected.

#### PGA AND ALC OPERATION

A programmable gain amplifier is provided in the input path to the ADC. This may be used manually or in conjunction with a mixed analogue/digital automatic level control (ALC) which keeps the recording volume constant.

#### AUX INPUT

The device includes a mono input, AUX, that can be used as an input for warning tones (beep) etc. This path can also be summed into the input in a flexible fashion, either to the input PGA as a second microphone input or as a line input. The configuration of this circuit, with integrated on-chip resistors allows several analogue signals to be summed into the single AUX input if required.

#### ADC

The mono ADC uses a multi-bit high-order oversampling architecture to deliver optimum performance with low power consumption. Various sample rates are supported, from the 8ks/s rate typically used in voice dictation, up to the 48ks/s rate used in high quality audio applications.

#### DIGITAL FILTERING

Advanced Sigma Delta Converters are used along with digital decimation and interpolation filters to give high quality audio at sample rates from 8ks/s to 48ks/s.

Application specific digital filters are also available which help to reduce the effect of specific noise sources such as 'wind noise'. The filters include a programmable ADC high-pass filter, an IIR filter with fully programmable coefficients, and a 5-band equaliser that can be applied to the record path in order to improve the overall audio sound from the device.

#### AUDIO INTERFACES

The WM8950 has a standard audio interface, to support the transmission of audio data from the chip. This interface is a 4 wire standard audio interface which supports a number of audio data formats including I<sup>2</sup>S, DSP Mode, MSB-First, left justified and MSB-First, right justified, and can operate in master or slave modes.

#### CONTROL INTERFACES

To allow full software control over all its features, the WM8950 offers a choice of 2 or 3 wire MPU control interface. It is fully compatible and an ideal partner for a wide range of industry standard microprocessors, controllers and DSPs. The selection between 2-wire mode and 3-wire mode is determined by the state of the MODE pin. If MODE is high then 3-wire control mode is selected, if MODE is low then 2-wire control mode is selected.

In 2 wire mode, only slave operation is supported, and the address of the device is fixed as 0011010.

#### CLOCKING SCHEMES

WM8950 offers the normal audio clocking scheme operation, where 256fs MCLK is provided to the ADC.

However, a PLL is also included which may be used to generate the internal master clock frequency in the event that this is not available from the system controller. The PLL uses an input reference (typically, the 12MHz USB clock) to generate high quality audio clocks. If the PLL is not required for generation of these clocks, it can be reconfigured to generate alternative clocks which may then be output on the CSB/GPIO pin and used elsewhere in the system.

## POWER CONTROL

The design of the WM8950 has given much attention to power consumption without compromising performance. It operates at low supply voltages, and includes the facility to power off any unused parts of the circuitry under software control, includes standby and power off modes.

## INPUT SIGNAL PATH

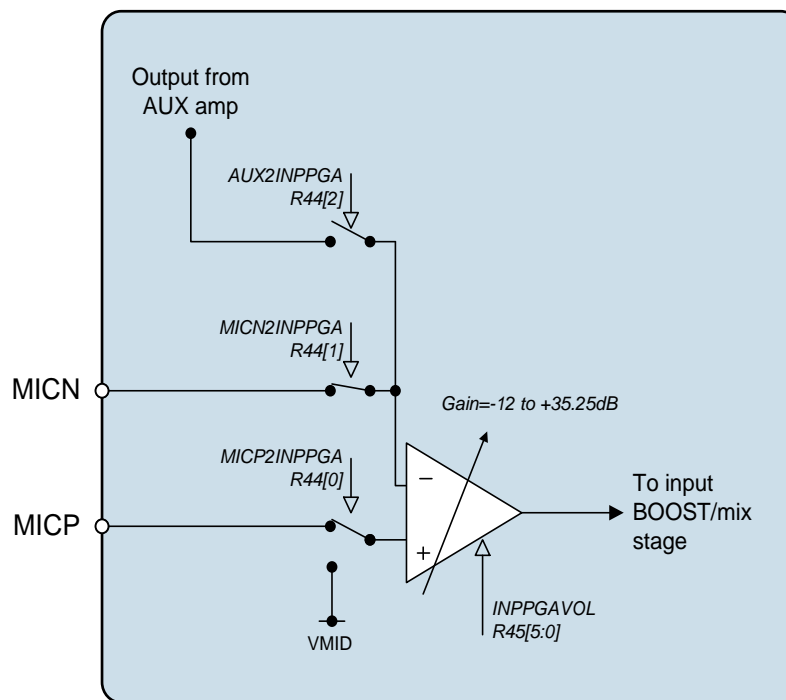
The WM8950 has 3 flexible analogue inputs: two microphone inputs, and an auxiliary input. These inputs can be used in a variety of ways. The input signal path before the ADC has a flexible PGA block which then feeds into a gain boost/mixer stage.

### MICROPHONE INPUTS

The WM8950 can accommodate a variety of microphone configurations including single ended and differential inputs. The inputs through the MICN, MICP and optionally AUX pins are amplified through the input PGA as shown in Figure 6 .

A pseudo differential input is the preferential configuration where the positive terminal of the input PGA is connected to the MICP input pin by setting MICP2INPPGA=1. The microphone ground should then be connected to MICN (when MICN2INPPGA=1) or optionally to AUX (when AUX2INPPGA=1) input pins.

Alternatively a single ended microphone can be connected to the MICN input with MICN2INPPGA set to 1. The non-inverting terminal of the input PGA should be connected internally to VMID by setting MICP2INPPGA to 0.



**Figure 6 Microphone Input PGA Circuit (switch positions shown are for differential mic input)**

REGISTER ADDRESS	BIT	LABEL	DEFAULT	DESCRIPTION
R44 Input Control	0	MICP2INPPGA	1	Connect input PGA amplifier positive terminal to MICP or VMID. 0 = input PGA amplifier positive terminal connected to VMID 1 = input PGA amplifier positive terminal connected to MICP through variable resistor string
	1	MICN2INPPGA	1	Connect MICN to input PGA negative terminal. 0=MICN not connected to input PGA 1=MICN connected to input PGA amplifier negative terminal.
	2	AUX2INPPGA	0	Select AUX amplifier output as input PGA signal source. 0=AUX not connected to input PGA 1=AUX connected to input PGA amplifier negative terminal.

The input PGA is enabled by the IPPGAEN register bit.

REGISTER ADDRESS	BIT	LABEL	DEFAULT	DESCRIPTION
R2 Power Management 2	2	INPPGAEN	0	Input microphone PGA enable 0 = disabled 1 = enabled

### INPUT PGA VOLUME CONTROL

The input microphone PGA has a gain range from -12dB to +35.25dB in 0.75dB steps. The gain from the MICN input to the PGA output and from the AUX amplifier to the PGA output are always common and controlled by the register bits INPPGAVOL[5:0]. These register bits also affect the MICP pin when MICP2INPPGA=1.

When the Automatic Level Control (ALC) is enabled the input PGA gain is then controlled automatically and the INPPGAVOL bits should not be used.

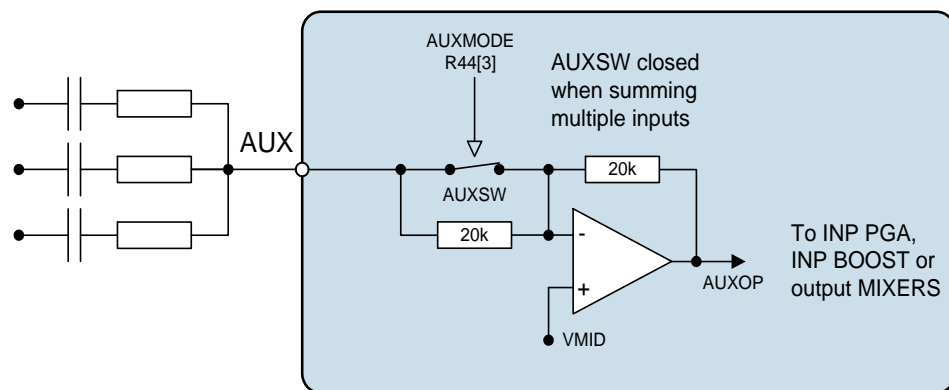
REGISTER ADDRESS	BIT	LABEL	DEFAULT	DESCRIPTION
R45 Input PGA volume control	5:0	INPPGAVOL	010000	Input PGA volume 000000 = -12dB 000001 = -11.25dB . 010000 = 0dB . 111111 = 35.25dB
	6	INPPGAMUTE	0	Mute control for input PGA: 0=Input PGA not muted, normal operation 1=Input PGA muted (and disconnected from the following input BOOST stage).
	7	INPPGAZC	0	Input PGA zero cross enable: 0=Update gain when gain register changes 1=Update gain on 1 <sup>st</sup> zero cross after gain register write.

REGISTER ADDRESS	BIT	LABEL	DEFAULT	DESCRIPTION
R32 ALC control 1	8	ALCSEL	0	ALC function select: 0=ALC off (PGA gain set by INPPGAVOL register bits) 1=ALC on (ALC controls PGA gain)

**Table 1 Input PGA Volume Control**

### AUXILIARY INPUT

An auxiliary input circuit (Figure 7) is provided which consists of an amplifier which can be configured either as an inverting buffer for a single input signal or as a mixer/summer for multiple inputs with the use of external resistors. The circuit is enabled by the register bit AUXEN.


**Figure 7 Auxiliary Input Circuit**

The AUXMODE register bit controls the auxiliary input mode of operation:

In buffer mode (AUXMODE=0) the switch labelled AUXSW in Figure 7 is open and the signal at the AUX pin will be buffered and inverted through the aux circuit using only the internal components.

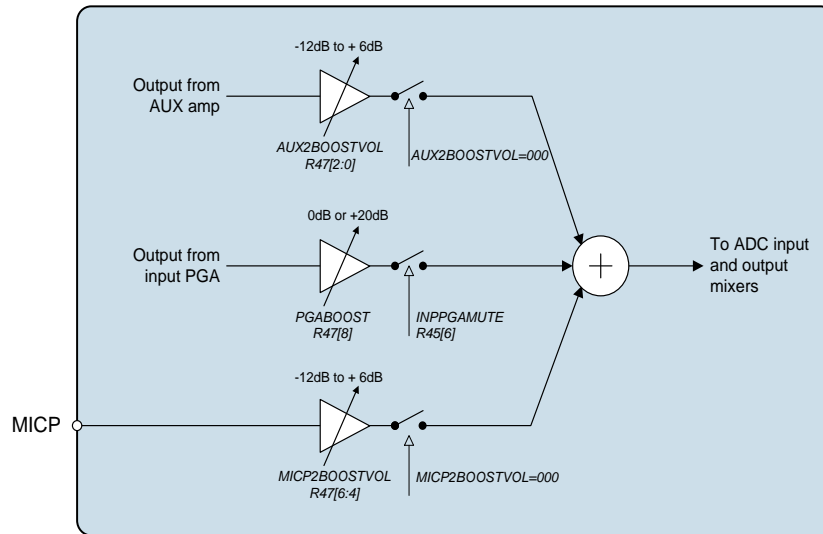
In mixer mode (AUXMODE=1) the on-chip input resistor is bypassed, this allows the user to sum in multiple inputs with the use of external resistors. When used in this mode there will be gain variations through this path from part to part due to the variation of the internal 20kΩ resistors relative to the higher tolerance external resistors.

REGISTER ADDRESS	BIT	LABEL	DEFAULT	DESCRIPTION
R1 Power management 1	6	AUXEN	0	Auxiliary input buffer enable 0 = OFF 1 = ON
R44 Input control	3	AUXMODE	0	0 = inverting buffer 1 = mixer (on-chip input resistor bypassed)

**Table 2 Auxiliary Input Buffer Control**

**INPUT BOOST**

The input BOOST circuit has 3 selectable inputs: the input microphone PGA output, the AUX amplifier output and the MICP input pin (when not using a differential microphone configuration). These three inputs can be mixed together and have individual gain boost/adjust as shown in Figure 8.



**Figure 8 Input Boost Stage**

The input PGA path can have a +20dB boost (PGABOOST=1) a 0dB pass through (PGABOOST=0) or be completely isolated from the input boost circuit (INPPGAMUTE=1).

REGISTER ADDRESS	BIT	LABEL	DEFAULT	DESCRIPTION
R45 Input PGA gain control	6	INPPGAMUTE	0	Mute control for input PGA: 0=Input PGA not muted, normal operation 1=Input PGA muted (and disconnected from the following input BOOST stage).
R47 Input BOOST control	8	PGABOOST	1	0 = PGA output has +0dB gain through input BOOST stage. 1 = PGA output has +20dB gain through input BOOST stage.

**Table 3 Input BOOST Stage Control**

The Auxiliary amplifier path to the BOOST stage is controlled by the AUX2BOOSTVOL[2:0] register bits. When AUX2BOOSTVOL=000 this path is completely disconnected from the BOOST stage. Settings 001 through to 111 control the gain in 3dB steps from -12dB to +6dB.

The MICP path to the BOOST stage is controlled by the MICP2BOOSTVOL[2:0] register bits. When MICP2BOOSTVOL=000 this input pin is completely disconnected from the BOOST stage. Settings 001 through to 111 control the gain in 3dB steps from -12dB to +6dB.



REGISTER ADDRESS	BIT	LABEL	DEFAULT	DESCRIPTION
R47 Input BOOST control	2:0	AUX2BOOSTVOL	000	Controls the auxiliary amplifier to the input boost stage: 000=Path disabled (disconnected) 001=-12dB gain through boost stage 010=-9dB gain through boost stage ... 111=+6dB gain through boost stage
	6:4	MICP2BOOSTVOL	000	Controls the MICP pin to the input boost stage (NB, when using this path set MICPZIUNPPGA=0): 000=Path disabled (disconnected) 001=-12dB gain through boost stage 010=-9dB gain through boost stage ... 111=+6dB gain through boost stage

**Table 4 Input BOOST Stage Control**

The BOOST stage is enabled under control of the BOOSTEN register bit.

REGISTER ADDRESS	BIT	LABEL	DEFAULT	DESCRIPTION
R2 Power management 2	4	BOOSTEN	0	Input BOOST enable 0 = Boost stage OFF 1 = Boost stage ON

**Table 5 Input BOOST Enable Control**

### MICROPHONE BIASING CIRCUIT

The MICBIAS output provides a low noise reference voltage suitable for biasing electret type microphones and the associated external resistor biasing network. Refer to the Applications Information section for recommended external components. The MICBIAS voltage can be altered via the MBVSEL register bit. If MBVSEL = 0, the MICBIAS voltage is 0.9 x AVDD. If MBVSEL = 1, the MICBIAS voltage is 0.75 x AVDD. The output can be enabled or disabled using MICBEN.

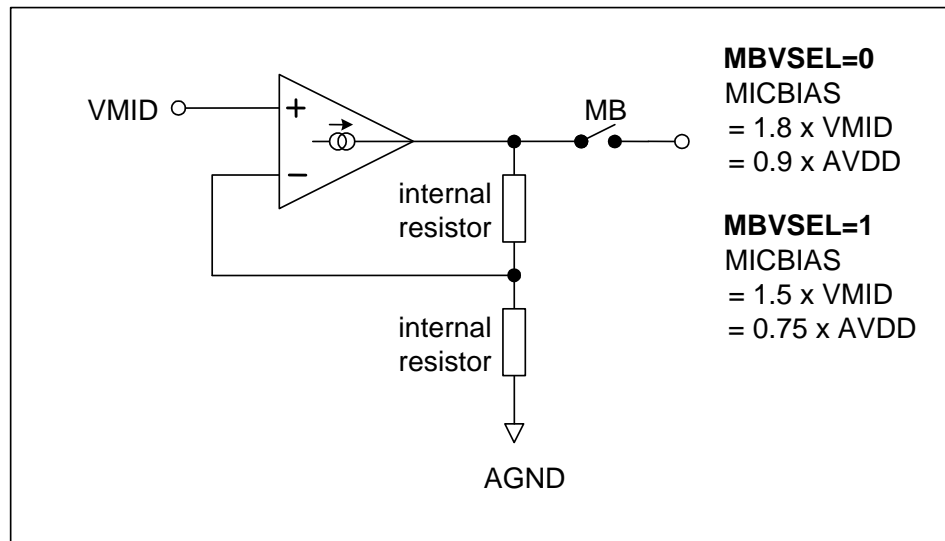
REGISTER ADDRESS	BIT	LABEL	DEFAULT	DESCRIPTION
R1 Power management 1	4	MICBEN	0	Microphone Bias Enable 0 = OFF (high impedance output) 1 = ON

**Table 6 Microphone Bias Enable**

REGISTER ADDRESS	BIT	LABEL	DEFAULT	DESCRIPTION
R44 Input Control	8	MBVSEL	0	Microphone Bias Voltage Control 0 = 0.9 x AVDD 1 = 0.75 x AVDD

**Table 7 Microphone Bias Voltage Control**

The internal MICBIAS circuitry is shown in Figure 9. Note that the maximum source current capability for MICBIAS is 3mA. The external biasing resistors therefore must be large enough to limit the MICBIAS current to 3mA.

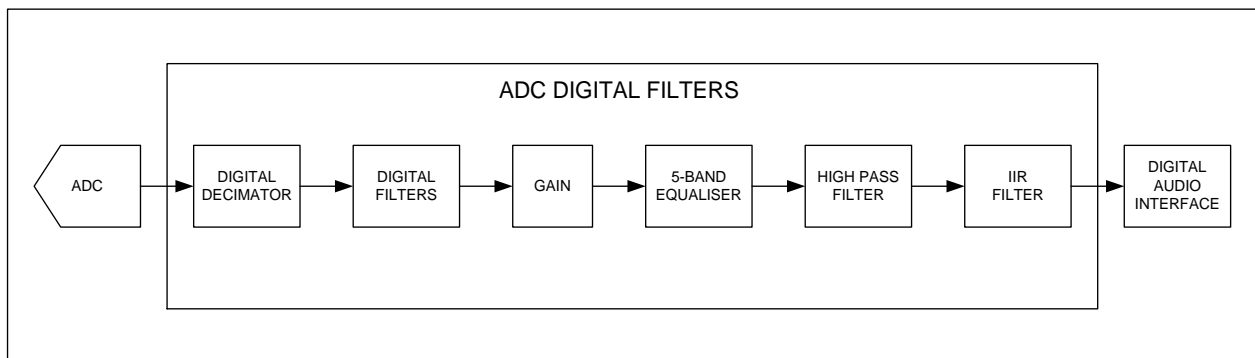

**Figure 9 Microphone Bias Schematic**

## ANALOGUE TO DIGITAL CONVERTER (ADC)

The WM8950 uses a multi-bit, oversampled sigma-delta ADC channel. The use of multi-bit feedback and high oversampling rates reduces the effects of jitter and high frequency noise. The ADC Full Scale input level is proportional to AVDD. With a 3.3V supply voltage, the full scale level is  $1.0V_{rms}$ . Any voltage greater than -1dBfs may overload the ADC and cause distortion.

### ADC DIGITAL FILTERS

The ADC filters perform true 24 bit signal processing to convert the raw multi-bit oversampled data from the ADC to the correct sampling frequency to be output on the digital audio interface. The digital filter path is illustrated in Figure 10 .


**Figure 10 ADC Digital Filter Path**

The ADC is enabled by the ADCEN register bit.

REGISTER ADDRESS	BIT	LABEL	DEFAULT	DESCRIPTION
R2 Power management 2	0	ADCEN	0	0 = ADC disabled 1 = ADC enabled

**Table 8 ADC Enable**

The polarity of the output signal can also be changed under software control using the ADCPOL register bit. The oversampling rate of the ADC can be adjusted using the ADCOSR register bit. With ADCOSR=0 the oversample rate is 64x which gives lowest power operation and when ADCOSR=1 the oversample rate is 128x which gives best performance.

REGISTER ADDRESS	BIT	LABEL	DEFAULT	DESCRIPTION
R14 ADC Control	3	ADCOSR	0	ADC oversample rate select: 0=64x (lower power) 1=128x (best performance)
	0	ADCPOL	0	0=normal 1=inverted

**Table 9 ADC Oversample Rate Select**

### SELECTABLE HIGH-PASS FILTER

A selectable high-pass filter is provided. To disable this filter set HPFEN=0. The filter has two modes controlled by HPFAPP. In Audio Mode (HPFAPP=0) the filter is first order, with a cut-off frequency of 3.7Hz. In Application Mode (HPFAPP=1) the filter is second order, with a cut-off frequency selectable via the HPFCUT register. The cut-off frequencies when HPFAPP=1 are shown in Table 11.

REGISTER ADDRESS	BIT	LABEL	DEFAULT	DESCRIPTION
R14 ADC Control	8	HPFEN	1	High-Pass Filter Enable 0=disabled 1=enabled
	7	HPFAPP	0	Select audio mode or application mode 0=Audio mode (1 <sup>st</sup> order, fc = ~3.7Hz) 1=Application mode (2 <sup>nd</sup> order, fc = HPFCUT)
	6:4	HPFCUT	000	Application mode cut-off frequency See Table 11 for details.

**Table 10 ADC Filter Select**

HPFCUT [2:0]	SAMPLE FREQUENCY (kHz)								
	8	11.025	12	16	22.05	24	32	44.1	48
	SR=101/100			SR=011/010			SR=001/000		
000	82	113	122	82	113	122	82	113	122
001	102	141	153	102	141	153	102	141	153
010	131	180	196	131	180	196	131	180	196
011	163	225	245	163	225	245	163	225	245
100	204	281	306	204	281	306	204	281	306
101	261	360	392	261	360	392	261	360	392
110	327	450	490	327	450	490	327	450	490
111	408	563	612	408	563	612	408	563	612

**Table 11 High-Pass Filter Cut-off Frequencies (HPFAPP=1) Values in Hz**

Note that the High-Pass filter values (when HPFAPP=1) work on the basis that the SR register bits are set correctly for the actual sample rate as shown in Table 11.

**PROGRAMMABLE IIR FILTER**

An IIR filter with fully programmable coefficients is provided, typically used as a notch filter for removing narrow band noise at a given frequency. This notch filter has a variable centre frequency and bandwidth, programmable via two coefficients, a0 and a1. These coefficients should be converted to 2's complement numbers to determine the register values. a0 and a1 are represented by the register bits NFA0[13:0] and NFA1[13:0]. Because these coefficient values require four register writes to setup there is an NFU (Notch Filter Update) flag which should be set only when all four registers are setup.

REGISTER ADDRESS	BIT	LABEL	DEFAULT	DESCRIPTION
R27 Notch Filter 1	6:0	NFA0[13:7]	0	Notch filter a0 coefficient, bits [13:7]
	7	NFEN	0	Notch filter enable: 0=Disabled 1=Enabled
	8	NFU	0	Notch filter update. The notch filter values used internally only update when one of the NFU bits is set high.
R28 Notch Filter 2	6:0	NFA0[6:0]	0	Notch filter a0 coefficient, bits [6:0]
	8	NFU]	0	Notch filter update. The notch filter values used internally only update when one of the NFU bits is set high.
R29 Notch Filter 3	6:0	NFA1[13:7]	0	Notch filter a1 coefficient, bits [13:7]
	8	NFU	0	Notch filter update. The notch filter values used internally only update when one of the NFU bits is set high.
R30 Notch Filter 4	6:0	NFA1[6:0]	0	Notch filter a1 coefficient, bits [6:0]
	8	NFU	0	Notch filter update. The notch filter values used internally only update when one of the NFU bits is set high.

**Table 12 Notch Filter Function**

The coefficients are calculated as follows:

$$a_0 = \frac{1 - \tan(w_b / 2)}{1 + \tan(w_b / 2)}$$

$$a_1 = -(1 + a_0) \cos(w_0)$$

Where:

$$w_0 = 2\pi f_c / f_s$$

$$w_b = 2\pi f_b / f_s$$

$f_c$  = centre frequency in Hz,  $f_b$  = -3dB bandwidth in Hz,  $f_s$  = sample frequency in Hz

The coefficients are calculated as follows:

$$NFA0 = -a_0 \times 2^{13}$$

$$NFA1 = -a_1 \times 2^{12}$$

These values are then converted to 2's complement notation to determine the register values.

**NOTCH FILTER WORKED EXAMPLE**

The following example illustrates how to calculate the a0 and a1 coefficients for a desired centre frequency and -3dB bandwidth.

$$f_c = 1000 \text{ Hz}$$

$$f_b = 100 \text{ Hz}$$

$$f_s = 48000 \text{ Hz}$$

$$w_0 = 2\pi f_c / f_s = 2\pi \times (1000 / 48000) = 0.1308996939 \text{ rads}$$

$$w_b = 2\pi f_b / f_s = 2\pi \times (100 / 48000) = 0.01308996939 \text{ rads}$$

$$a_0 = \frac{1 - \tan(w_b / 2)}{1 + \tan(w_b / 2)} = \frac{1 - \tan(0.01308996939 / 2)}{1 + \tan(0.01308996939 / 2)} = 0.9869949627$$

$$a_1 = -(1 + a_0) \cos(w_0) = -(1 + 0.9869949627) \cos(0.1308996939) = -1.969995945$$

$$NFn\_A0 = -a_0 \times 213 = -8085 \text{ (rounded to nearest whole number)}$$

$$NFn\_A1 = -a_1 \times 212 = 8069 \text{ (rounded to nearest whole number)}$$

These values are then converted to 2's complement:

$$NFA0 = 14'h206B = 14'b10000001101011$$

$$NFA1 = 14'h1F85 = 14'b01111110000101$$

**DIGITAL ADC VOLUME CONTROL**

The output of the ADCs can be digitally attenuated over a range from -127dB to 0dB in 0.5dB steps. The gain for a given eight-bit code X is given by:

$$\text{Gain} = 0.5 \times (x - 255) \text{ dB for } 1 \leq x \leq 255, \text{ MUTE for } x = 0$$

REGISTER ADDRESS	BIT	LABEL	DEFAULT	DESCRIPTION
R15 ADC Digital Volume	7:0	ADCVOL [7:0]	11111111 ( 0dB )	ADC Digital Volume Control 0000 0000 = Digital Mute 0000 0001 = -127dB 0000 0010 = -126.5dB ... 0.5dB steps up to 1111 1111 = 0dB

**Table 13 ADC Volume**

**INPUT AUTOMATIC LEVEL CONTROL (ALC)**

The WM8950 has an automatic PGA gain control circuit, which can function as an input peak limiter or as an automatic level control (ALC).

The Automatic Level Control (ALC) provides continuous adjustment of the input PGA in response to the amplitude of the input signal. A digital peak detector monitors the input signal amplitude and compares it to a register defined threshold level (ALCLVL).

If the signal is below the threshold, the ALC will increase the gain of the PGA at a rate set by ALCDY. If the signal is above the threshold, the ALC will reduce the gain of the PGA at a rate set by ALCATK.

The ALC has two modes selected by the ALCMODE register: normal mode and peak limiter mode. The ALC/limiter function is enabled by setting the register bit R32[8] ALCSEL.

REGISTER ADDRESS	BIT	LABEL	DEFAULT	DESCRIPTION
R32 (20h) ALC Control 1	2:0	ALCMIN [2:0]	000 (-12dB)	Set minimum gain of PGA 000 = -12dB 001 = -6dB 010 = 0dB 011 = +6dB 100 = +12dB 101 = +18dB 110 = +24dB 111 = +30dB
	5:3	ALCMAX [2:0]	111 (+35.25dB)	Set Maximum Gain of PGA 111 = +35.25dB 110 = +29.25dB 101 = +23.25dB 100 = +17.25dB 011 = +11.25dB 010 = +5.25dB 001 = -0.75dB 000 = -6.75dB
	8	ALCSEL	0	ALC function select 0 = ALC disabled 1 = ALC enabled
R33 (21h) ALC Control 2	3:0	ALCLVL [3:0]	1011 (-12dB)	ALC target – sets signal level at ADC input 1111 = -6dBFS 1110 = -7.5dBFS 1101 = -9dBFS 1100 = -10.5dBFS 1011 = -12dBFS 1010 = -13.5dBFS 1001 = -15dBFS 1000 = -16.5dBFS 0111 = -18dBFS 0110 = -19.5dBFS 0101 = -21dBFS 0100 = -22.5dBFS 0011 = -24dBFS 0010 = -25.5dBFS 0001 = -27dBFS 0000 = -28.5dBFS

REGISTER ADDRESS	BIT	LABEL	DEFAULT	DESCRIPTION																					
	8	ALCZC	0 (zero cross off)	ALC uses zero cross detection circuit. 0 = Disabled (recommended) 1 = Enabled																					
	7:4	ALCHLD [3:0]	0000 (0ms)	ALC hold time before gain is increased. 0000 = 0ms 0001 = 2.67ms 0010 = 5.33ms 0011 = 10.66ms 0100 = 21.32ms 0101 = 42.64ms 0110 = 85.28ms 0111 = 0.17s 1000 = 0.34s 1001 = 0.68s 1010 or higher = 1.36s																					
R34 (22h) ALC Control 3	8	ALCMODE	0	Determines the ALC mode of operation: 0 = ALC mode (Normal Operation) 1 = Limiter mode.																					
	7:4	ALCDCY [3:0]	0011 (26ms/6dB)	Decay (gain ramp-up) time (ALCMODE ==0)																					
				<table border="1"> <thead> <tr> <th></th> <th>Per step</th> <th>Per 6dB</th> <th>90% of range</th> </tr> </thead> <tbody> <tr> <td>0000</td> <td>410us</td> <td>3.38ms</td> <td>23.6ms</td> </tr> <tr> <td>0001</td> <td>820us</td> <td>6.56ms</td> <td>47.2ms</td> </tr> <tr> <td>0010</td> <td>1.64ms</td> <td>13.1ms</td> <td>94.5ms</td> </tr> <tr> <td colspan="4">... (time doubles with every step)</td> </tr> <tr> <td>1010 or higher</td> <td>420ms</td> <td>3.36s</td> <td>24.2s</td> </tr> </tbody> </table>		Per step	Per 6dB	90% of range	0000	410us	3.38ms	23.6ms	0001	820us	6.56ms	47.2ms	0010	1.64ms	13.1ms	94.5ms	... (time doubles with every step)				1010 or higher
	Per step	Per 6dB	90% of range																						
0000	410us	3.38ms	23.6ms																						
0001	820us	6.56ms	47.2ms																						
0010	1.64ms	13.1ms	94.5ms																						
... (time doubles with every step)																									
1010 or higher	420ms	3.36s	24.2s																						
0011 (5.8ms/6dB)	Decay (gain ramp-up) time (ALCMODE ==1)																								
	<table border="1"> <thead> <tr> <th></th> <th>Per step</th> <th>Per 6dB</th> <th>90% of range</th> </tr> </thead> <tbody> <tr> <td>0000</td> <td>90.8us</td> <td>726us</td> <td>5.23ms</td> </tr> <tr> <td>0001</td> <td>182us</td> <td>1.45ms</td> <td>10.5ms</td> </tr> <tr> <td>0010</td> <td>363us</td> <td>2.91ms</td> <td>20.9ms</td> </tr> <tr> <td colspan="4">... (time doubles with every step)</td> </tr> <tr> <td>1010</td> <td>93ms</td> <td>744ms</td> <td>5.36s</td> </tr> </tbody> </table>		Per step	Per 6dB	90% of range	0000	90.8us	726us	5.23ms	0001	182us	1.45ms	10.5ms	0010	363us	2.91ms	20.9ms	... (time doubles with every step)				1010	93ms	744ms	5.36s
	Per step	Per 6dB	90% of range																						
0000	90.8us	726us	5.23ms																						
0001	182us	1.45ms	10.5ms																						
0010	363us	2.91ms	20.9ms																						
... (time doubles with every step)																									
1010	93ms	744ms	5.36s																						
3:0	ALCATK [3:0]	0010 (3.3ms/6dB)	ALC attack (gain ramp-down) time (ALCMODE == 0)																						
	<table border="1"> <thead> <tr> <th></th> <th>Per step</th> <th>Per 6dB</th> <th>90% of range</th> </tr> </thead> <tbody> <tr> <td>0000</td> <td>104us</td> <td>832us</td> <td>6ms</td> </tr> <tr> <td>0001</td> <td>208us</td> <td>1.66ms</td> <td>12ms</td> </tr> <tr> <td>0010</td> <td>416us</td> <td>3.33ms</td> <td>24ms</td> </tr> <tr> <td colspan="4">... (time doubles with every step)</td> </tr> <tr> <td>1010 or higher</td> <td>106ms</td> <td>852ms</td> <td>6.13s</td> </tr> </tbody> </table>		Per step	Per 6dB	90% of range	0000	104us	832us	6ms	0001	208us	1.66ms	12ms	0010	416us	3.33ms	24ms	... (time doubles with every step)				1010 or higher	106ms	852ms	6.13s
	Per step	Per 6dB	90% of range																						
0000	104us	832us	6ms																						
0001	208us	1.66ms	12ms																						
0010	416us	3.33ms	24ms																						
... (time doubles with every step)																									
1010 or higher	106ms	852ms	6.13s																						

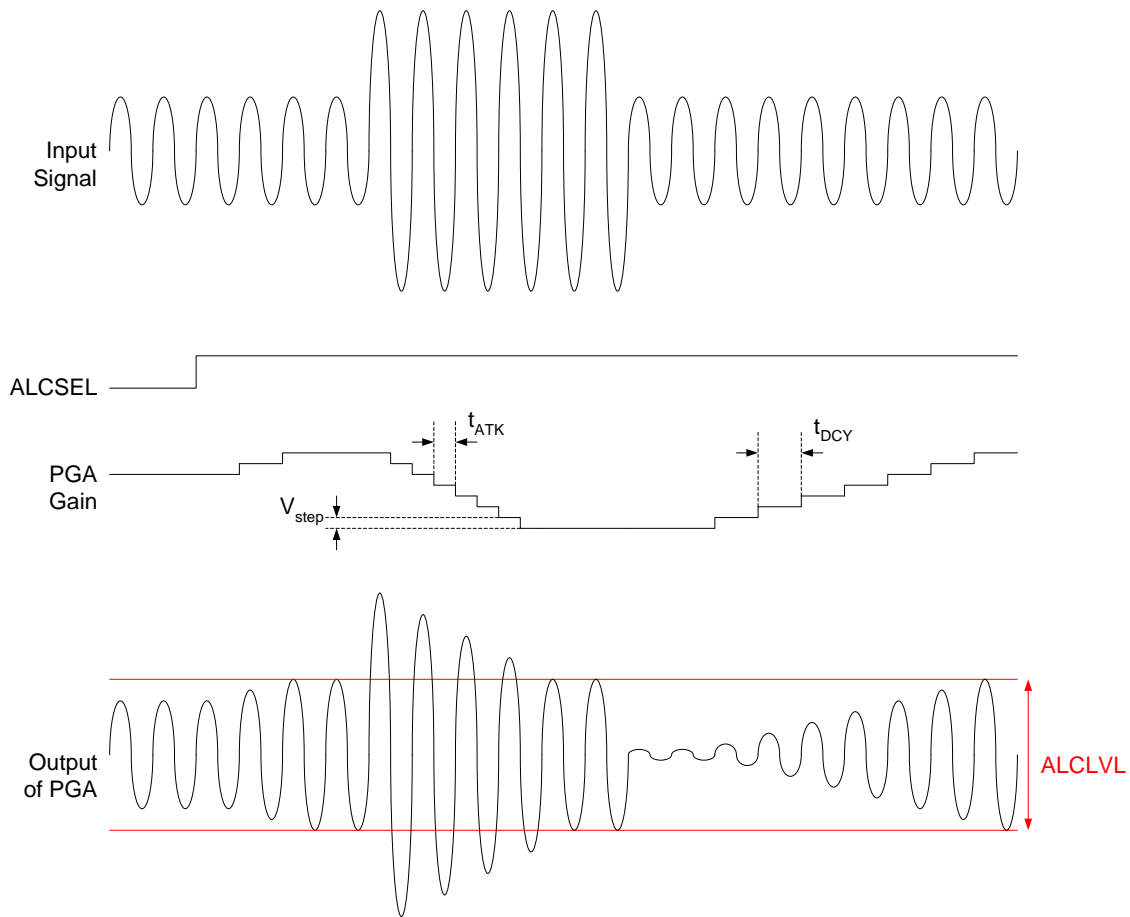
REGISTER ADDRESS	BIT	LABEL	DEFAULT	DESCRIPTION																								
			0010 (726us/6dB)	ALC attack (gain ramp-down) time (ALCMODE == 1)																								
				<table border="1"> <thead> <tr> <th></th> <th>Per step</th> <th>Per 6dB</th> <th>90% of range</th> </tr> </thead> <tbody> <tr> <td>0000</td> <td>22.7us</td> <td>182.4us</td> <td>1.31ms</td> </tr> <tr> <td>0001</td> <td>45.4us</td> <td>363us</td> <td>2.62ms</td> </tr> <tr> <td>0010</td> <td>90.8us</td> <td>726us</td> <td>5.23ms</td> </tr> <tr> <td colspan="4">... (time doubles with every step)</td> </tr> <tr> <td>1010 or higher</td> <td>23.2ms</td> <td>186ms</td> <td>1.34s</td> </tr> </tbody> </table>		Per step	Per 6dB	90% of range	0000	22.7us	182.4us	1.31ms	0001	45.4us	363us	2.62ms	0010	90.8us	726us	5.23ms	... (time doubles with every step)				1010 or higher	23.2ms	186ms	1.34s
	Per step	Per 6dB	90% of range																									
0000	22.7us	182.4us	1.31ms																									
0001	45.4us	363us	2.62ms																									
0010	90.8us	726us	5.23ms																									
... (time doubles with every step)																												
1010 or higher	23.2ms	186ms	1.34s																									

**Table 14 ALC Control Registers**

When the ALC is disabled, the input PGA remains at the last controlled value of the ALC. An input gain update must be made by writing to the INPPGAVOLL/R register bits.

### NORMAL MODE

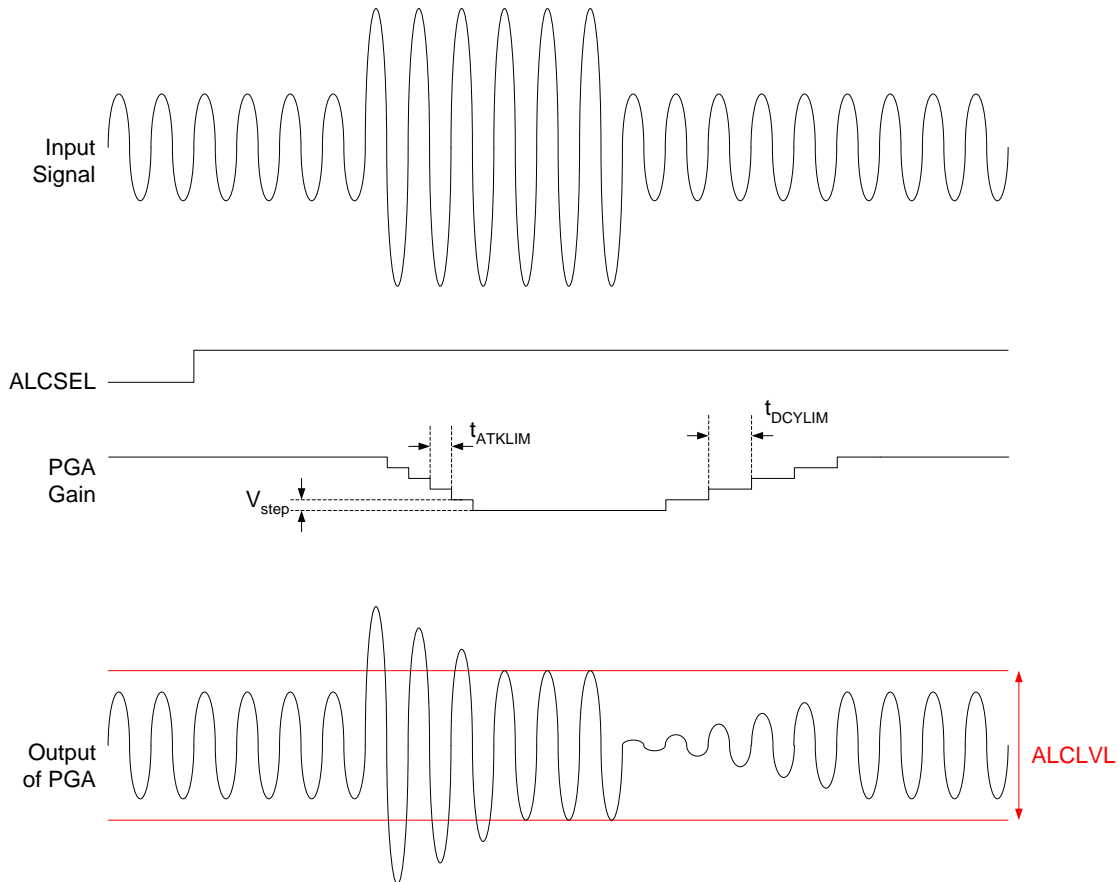
In normal mode, the ALC will attempt to maintain a constant signal level by increasing or decreasing the gain of the PGA. The following diagram shows an example of this.


**Figure 11 ALC Normal Mode Operation**



### LIMITER MODE

In limiter mode, the ALC will reduce peaks that go above the threshold level, but will not increase the PGA gain beyond the starting level. The starting level is the PGA gain setting when the ALC is enabled in limiter mode. If the ALC is started in limiter mode, this is the gain setting of the PGA at start-up. If the ALC is switched into limiter mode after running in ALC mode, the starting gain will be the gain at switchover. The diagram below shows an example of limiter mode.



**Figure 12 ALC Limiter Mode Operation**

### ATTACK AND DECAY TIMES

The attack and decay times set the update times for the PGA gain. The attack time is the time constant used when the gain is reducing. The decay time is the time constant used when the gain is increasing. In limiter mode, the time constants are faster than in ALC mode. The time constants are shown below in terms of a single gain step, a change of 6dB and a change of 90% of the PGAs gain range.

Note that, these times will vary slightly depending on the sample rate used (specified by the SR register).

**NORMAL MODE**

ALCMODE = 0 (Normal Mode)			
Attack Time (s)			
ALCATK	t <sub>ATK</sub>	t <sub>ATK6dB</sub>	t <sub>ATK90%</sub>
0000	104μs	832μs	6ms
0001	208μs	1.66ms	12ms
0010	416μs	3.33ms	24ms
0011	832μs	6.66ms	48ms
0100	1.66ms	13.3ms	96ms
0101	3.33ms	26.6ms	192ms
0110	6.66ms	53.2ms	384ms
0111	13.3ms	106ms	767ms
1000	26.6ms	213.2ms	1.53s
1001	53.2ms	426ms	3.07s
1010	106ms	852ms	6.13s

ALCMODE = 0 (Normal Mode)			
Decay Time (s)			
ALCDCY	t <sub>DCY</sub>	t <sub>DCY6dB</sub>	t <sub>DCY90%</sub>
0000	410μs	3.28ms	23.6ms
0001	820μs	6.56ms	47.2ms
0010	1.64ms	13.1ms	94.5ms
0011	3.28ms	26.2ms	189ms
0100	6.56ms	52.5ms	378ms
0101	13.1ms	105ms	756ms
0110	26.2ms	210ms	1.51s
0111	52.5ms	420ms	3.02s
1000	105ms	840ms	6.05s
1001	210ms	1.68s	12.1s
1010	420ms	3.36s	24.2s

**Table 15 ALC Normal Mode (Attack and Decay times)**
**LIMITER MODE**

ALCMODE = 1 (Limiter Mode)			
Attack Time (s)			
ALCATK	t <sub>ATKLIM</sub>	t <sub>ATKLIM6dB</sub>	t <sub>ATKLIM90%</sub>
0000	22.7μs	182μs	1.31ms
0001	45.4μs	363μs	2.62ms
0010	90.8μs	726μs	5.23ms
0011	182μs	1.45ms	10.5ms
0100	363μs	2.91ms	20.9ms
0101	726μs	5.81ms	41.8ms
0110	1.45ms	11.6ms	83.7ms
0111	2.9ms	23.2ms	167ms
1000	5.81ms	46.5ms	335ms
1001	11.6ms	93ms	669ms
1010	23.2ms	186ms	1.34s

ALCMODE = 1 (Limiter Mode)			
Attack Time (s)			
ALCDCY	t <sub>DCYLIM</sub>	t <sub>DCYLIM6dB</sub>	t <sub>DCYLIM90%</sub>
0000	90.8µs	726µs	5.23ms
0001	182µs	1.45ms	10.5ms
0010	363µs	2.91ms	20.9ms
0011	726µs	5.81ms	41.8ms
0100	1.45ms	11.6ms	83.7ms
0101	2.91ms	23.2ms	167ms
0110	5.81ms	46.5ms	335ms
0111	11.6ms	93ms	669ms
1000	23.2ms	186ms	1.34s
1001	46.5ms	372ms	2.68s
1010	93ms	744ms	5.36s

**Table 16 ALC Limiter Mode (Attack and Decay times)**
**MINIMUM AND MAXIMUM GAIN**

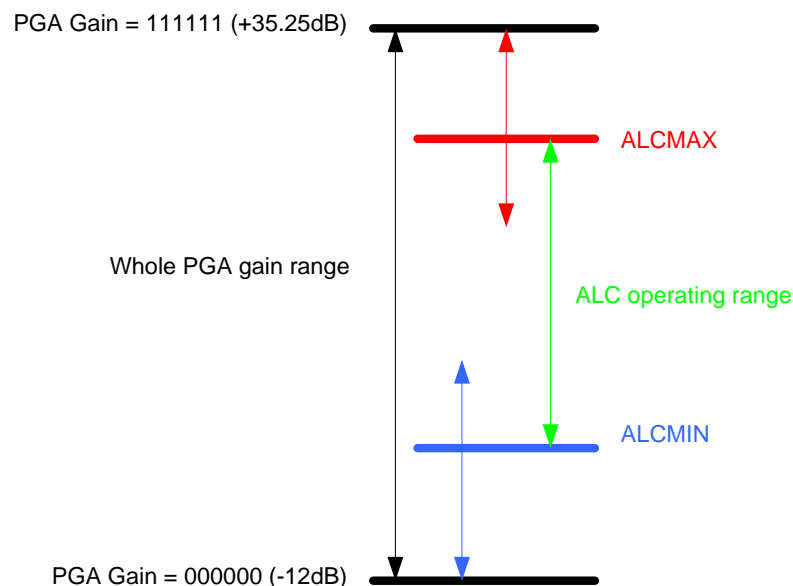
The ALCMIN and ALCMAX register bits set the minimum/maximum gain value that the PGA can be set to whilst under the control of the ALC. This has no effect on the PGA when ALC is not enabled.

REGISTER ADDRESS	BIT	LABEL	DEFAULT	DESCRIPTION
R32	5:3	ALCMAX	111	Set Maximum Gain of PGA
ALC Control 1	2:0	ALCMIN	000	Set minimum gain of PGA

**Table 17 ALC Max/Min Gain**

In normal mode, ALCMAX sets the maximum boost which can be applied to the signal. In limiter mode, ALCMAX will normally have no effect (assuming the starting gain value is less than the maximum gain specified by ALCMAX) because the maximum gain is set at the starting gain level.

ALCMIN sets the minimum gain value which can be applied to the signal.


**Figure 13 ALC Min/Max Gain**

ALCMAX	Maximum Gain (dB)
111	35.25
110	29.25
101	23.25
100	17.25
011	11.25
010	5.25
001	-0.75
000	-6.75

**Table 18 ALC Max Gain Values**

ALCMIN	Minimum Gain (dB)
000	-12
001	-6
010	0
011	6
100	12
101	18
110	24
111	30

**Table 19 ALC Min Gain Values**

Note that if the ALC gain setting strays outside the ALC operating range, either by starting the ALC outside of the range or changing the ALCMAX or ALCMIN settings during operation, the ALC will immediately adjust the gain to return to the ALC operating range. It is recommended that the ALC starting gain is set between the ALCMAX and ALCMIN limits.

### ALC HOLD TIME (NORMAL MODE ONLY)

In Normal mode, the ALC has an adjustable hold time which sets a time delay before the ALC begins its decay phase (gain increasing). The hold time is set by the ALCHLD register.

REGISTER ADDRESS	BIT	LABEL	DEFAULT	DESCRIPTION
R33 ALC Control 2	7:4	ALCHLD	0000	ALC hold time before gain is increased.

**Table 20 ALC Hold Time**

If the hold time is exceeded this indicates that the signal has reached a new average level and the ALC will increase the gain to adjust for that new average level. If the signal goes above the threshold during the hold period, the hold phase is abandoned and the ALC returns to normal operation.

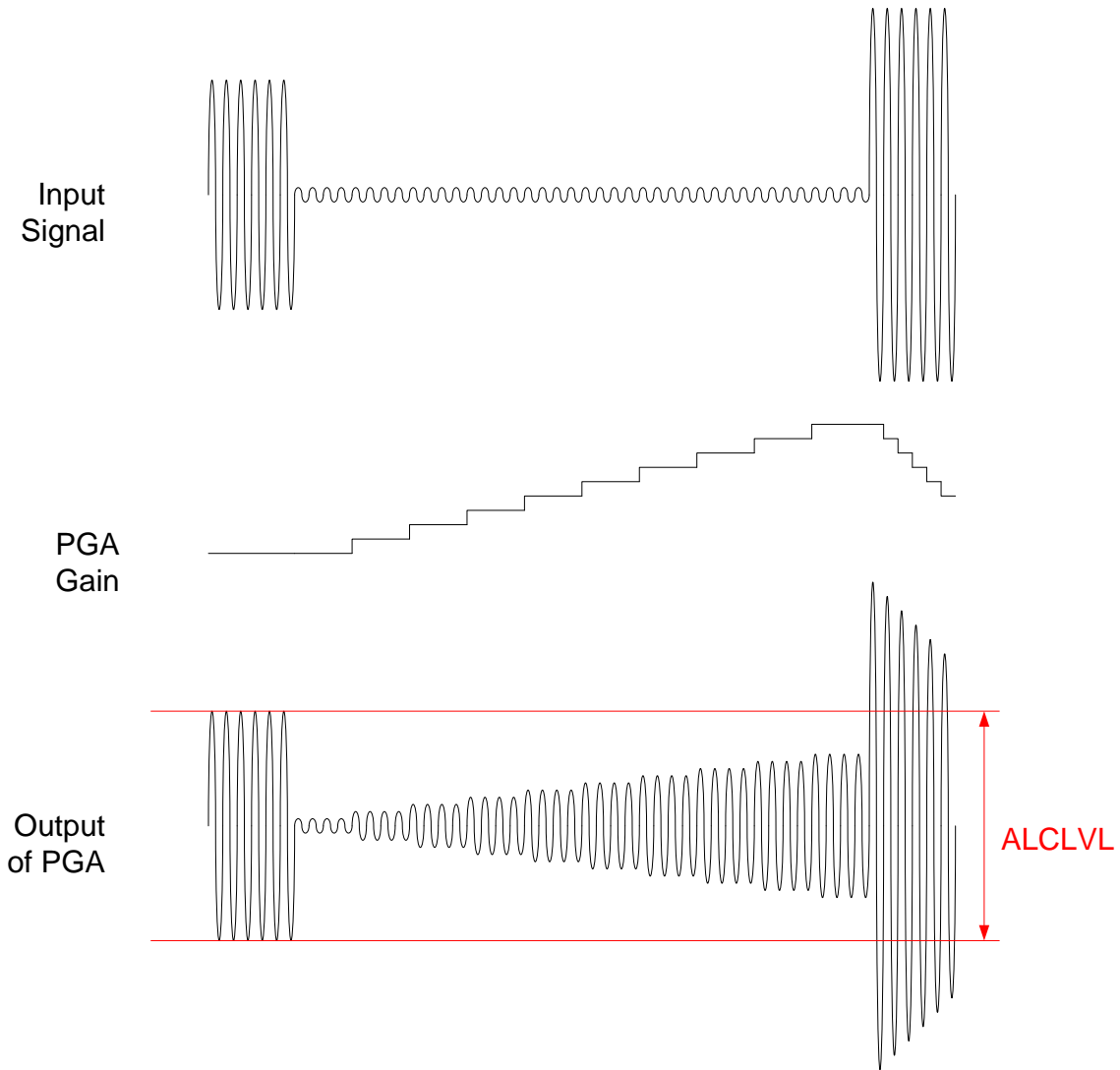


Figure 14 ALCLVL

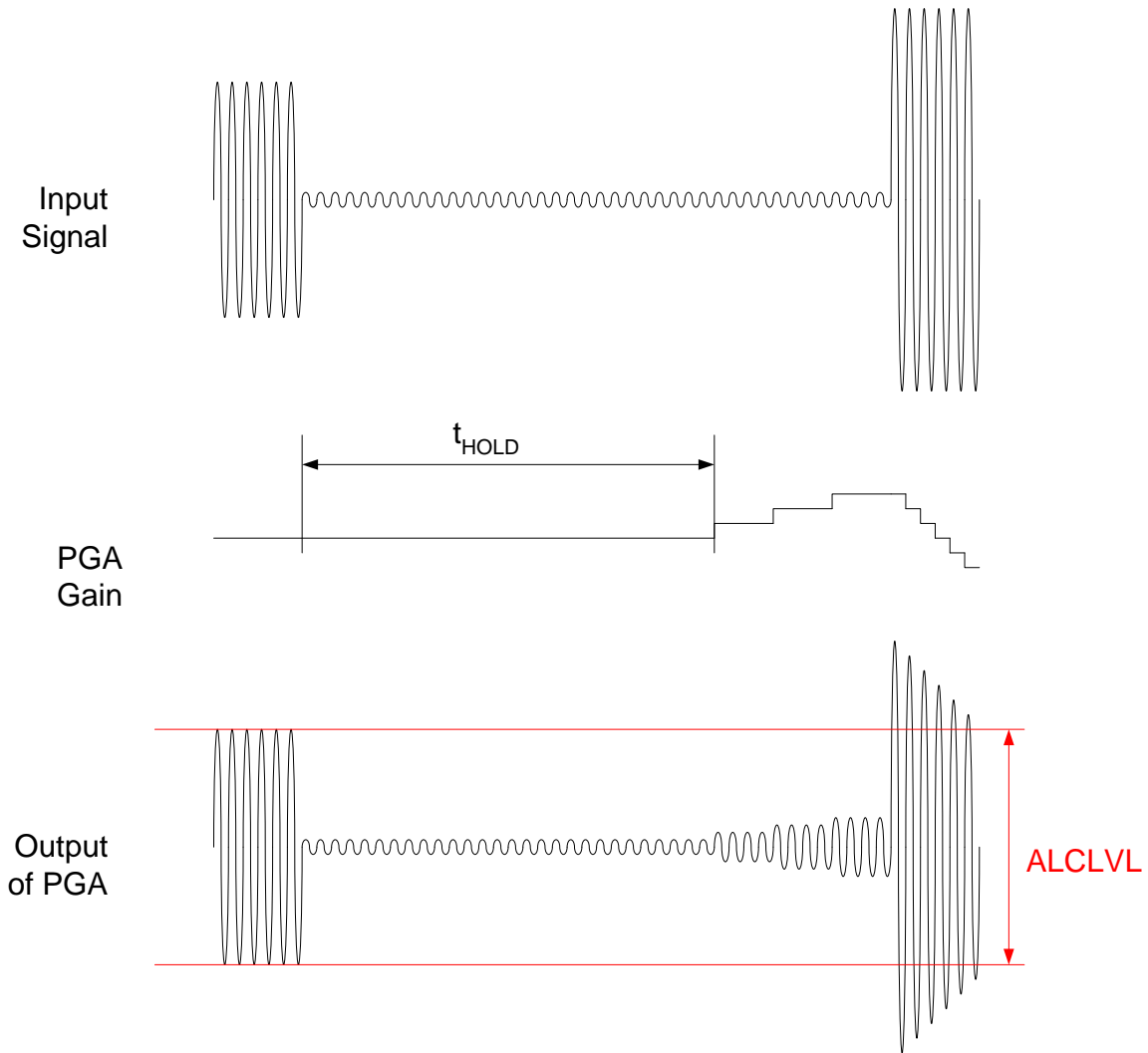


Figure 15 ALC Hold Time

ALCHLD	$t_{\text{HOLD}}$ (s)
0000	0
0001	2.67ms
0010	5.34ms
0011	10.7ms
0100	21.4ms
0101	42.7ms
0110	85.4ms
0111	171ms
1000	342ms
1001	684ms
1010	1.37s

Table 21 ALC Hold Time Values

**PEAK LIMITER**

To prevent clipping when a large signal occurs just after a period of quiet, the ALC circuit includes a limiter function. If the ADC input signal exceeds 87.5% of full scale (-1.16dB), the PGA gain is ramped down at the maximum attack rate (as when ALCATK = 0000), until the signal level falls below 87.5% of full scale. This function is automatically enabled whenever the ALC is enabled.

**Note:** If ALCATK = 0000, then the limiter makes no difference to the operation of the ALC. It is designed to prevent clipping when long attack times are used.

**NOISE GATE (NORMAL MODE ONLY)**

When the signal is very quiet and consists mainly of noise, the ALC function may cause “noise pumping”, i.e. loud hissing noise during silence periods. The WM8950 has a noise gate function that prevents noise pumping by comparing the signal level at the input pins against a noise gate threshold, NGTH. The noise gate cuts in when:

$$\text{Signal level at ADC [dBFS]} < \text{NGTH [dBFS]} + \text{PGA gain [dB]} + \text{Mic Boost gain [dB]}$$

This is equivalent to:

$$\text{Signal level at input pin [dBFS]} < \text{NGTH [dBFS]}$$

The PGA gain is then held constant (preventing it from ramping up as it normally would when the signal is quiet).

The table below summarises the noise gate control register. The NGTH control bits set the noise gate threshold with respect to the ADC full-scale range. The threshold is adjusted in 6dB steps. Levels at the extremes of the range may cause inappropriate operation, so care should be taken with set-up of the function. The noise gate only operates in conjunction with the ALC and cannot be used in limiter mode.

REGISTER ADDRESS	BIT	LABEL	DEFAULT	DESCRIPTION
R35 (23h) ALC Noise Gate Control	2:0	NGTH	000	Noise gate threshold: 000 = -39dB 001 = -45dB 010 = -51dB 011 = -57dB 100 = -63dB 101 = -69dB 110 = -75dB 111 = -81dB
	3	NGATEN	0	Noise gate function enable 1 = enable 0 = disable

**Table 22 ALC Noise Gate Control**

The diagrams below show the response of the system to the same signal with and without noise gate.

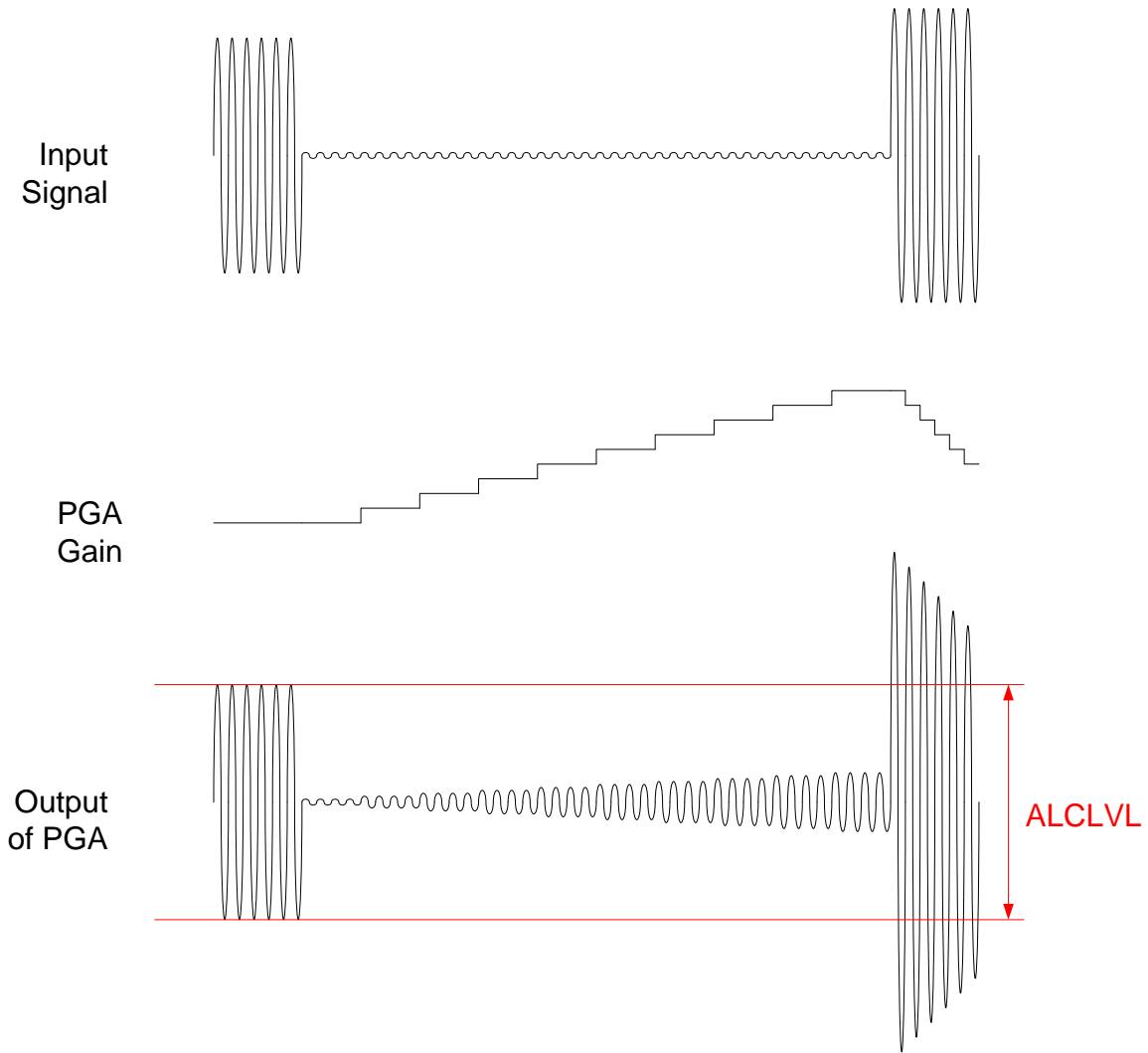
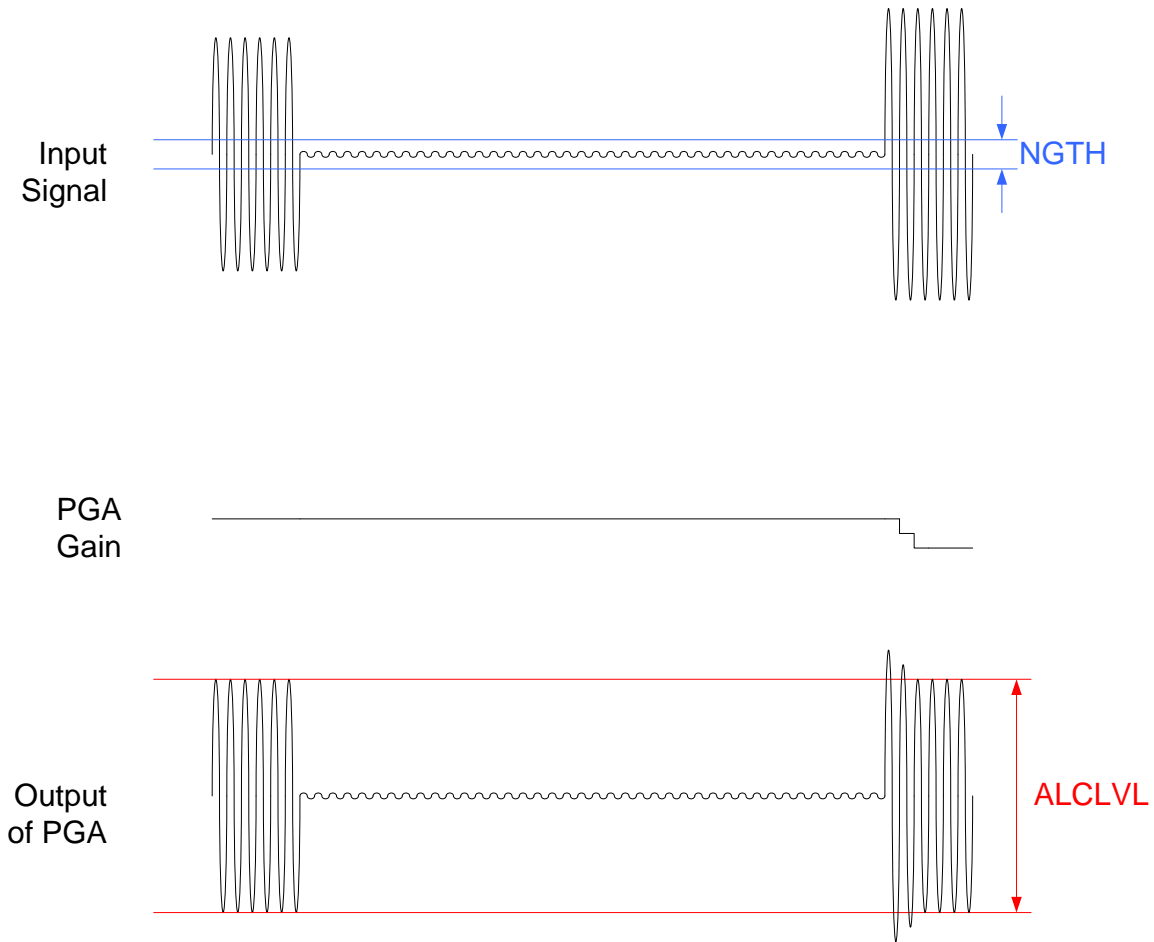


Figure 16 ALC Operation above Noise Gate Threshold





**Figure 17 Noise Gate Operation**

### GRAPHIC EQUALISER

A 5-band graphic EQ is provided, which can be applied to the ADC data under control of the EQMODE register bit.

REGISTER ADDRESS	BIT	LABEL	DEFAULT	DESCRIPTION
R18 EQ Control 1	8	EQMODE	1	0 = Equaliser applied to ADC data 1 = Equaliser bypassed

**Table 23 EQ Select**

The equaliser consists of low and high frequency shelving filters (Band 1 and 5) and three peak filters for the centre bands. Each has adjustable cut-off or centre frequency, and selectable boost (+/- 12dB in 1dB steps). The peak filters have selectable bandwidth.

REGISTER ADDRESS	BIT	LABEL	DEFAULT	DESCRIPTION
R18 EQ Band 1	4:0	EQ1G	01100 (0dB)	Band 1 Gain Control. See Table 29 for details.

REGISTER ADDRESS	BIT	LABEL	DEFAULT	DESCRIPTION
Control	6:5	EQ1C	01	Band 1 Cut-off Frequency: 00=80Hz 01=105Hz 10=135Hz 11=175Hz

**Table 24 EQ Band 1 Control**

REGISTER ADDRESS	BIT	LABEL	DEFAULT	DESCRIPTION
R19 EQ Band 2 Control	4:0	EQ2G	01100 (0dB)	Band 2 Gain Control. See Table 29 for details.
	6:5	EQ2C	01	Band 2 Centre Frequency: 00=230Hz 01=300Hz 10=385Hz 11=500Hz
	8	EQ2BW	0	Band 2 Bandwidth Control 0=narrow bandwidth 1=wide bandwidth

**Table 25 EQ Band 2 Control**

REGISTER ADDRESS	BIT	LABEL	DEFAULT	DESCRIPTION
R20 EQ Band 3 Control	4:0	EQ3G	01100 (0dB)	Band 3 Gain Control. See Table 29 for details.
	6:5	EQ3C	01	Band 3 Centre Frequency: 00=650Hz 01=850Hz 10=1.1kHz 11=1.4kHz
	8	EQ3BW	0	Band 3 Bandwidth Control 0=narrow bandwidth 1=wide bandwidth

**Table 26 EQ Band 3 Control**

REGISTER ADDRESS	BIT	LABEL	DEFAULT	DESCRIPTION
R21 EQ Band 4 Control	4:0	EQ4G	01100 (0dB)	Band 4 Gain Control. See Table 29 for details
	6:5	EQ4C	01	Band 4 Centre Frequency: 00=1.8kHz 01=2.4kHz 10=3.2kHz 11=4.1kHz
	8	EQ4BW	0	Band 4 Bandwidth Control 0=narrow bandwidth 1=wide bandwidth

**Table 27 EQ Band 4 Control**

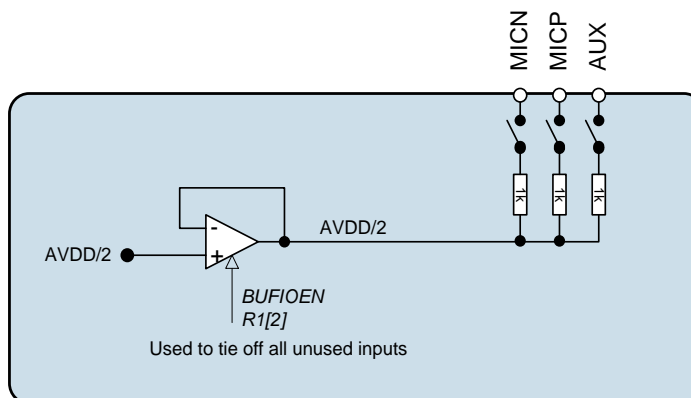
REGISTER ADDRESS	BIT	LABEL	DEFAULT	DESCRIPTION
R22 EQ Band 5 Gain Control	4:0	EQ5G	01100 (0dB)	Band 5 Gain Control. See Table 29 for details.
	6:5	EQ5C	01	Band 5 Cut-off Frequency: 00=5.3kHz 01=6.9kHz 10=9kHz 11=11.7kHz

**Table 28 EQ Band 5 Control**

GAIN REGISTER	GAIN
00000	+12dB
00001	+11dB
00010	+10dB
.... (1dB steps)	
01100	0dB
01101	-1dB
11000 to 11111	-12dB

**Table 29 Gain Register Table**

A dedicated buffer is available for tying off unused analogue input pins as shown below Figure 18. This buffer can be enabled using the BUFIOEN register bit.


**Figure 18 Unused Input Pin Tie-off Buffers**

### THERMAL SHUTDOWN

To protect the WM8950 from overheating a thermal shutdown circuit is included. If the device temperature reaches approximately 125°C and the thermal shutdown circuit is enabled (TSDEN=1), an interrupt can be generated. See the GPIO and Interrupt Controller section for details.

REGISTER ADDRESS	BIT	LABEL	DEFAULT	DESCRIPTION
R49 Output control	1	TSDEN	1	Thermal Shutdown Enable 0 : thermal shutdown disabled 1 : thermal shutdown enabled

**Table 30 Thermal Shutdown**

## DIGITAL AUDIO INTERFACES

The audio interface has three pins:

- ADCDAT: ADC data output
- FRAME: Data alignment clock
- BCLK: Bit clock, for synchronisation

The clock signals BCLK, and FRAME can be outputs when the WM8950 operates as a master, or inputs when it is a slave (see Master and Slave Mode Operation, below).

Five different audio data formats are supported:

- Left justified
- Right justified
- I<sup>2</sup>S
- DSP mode

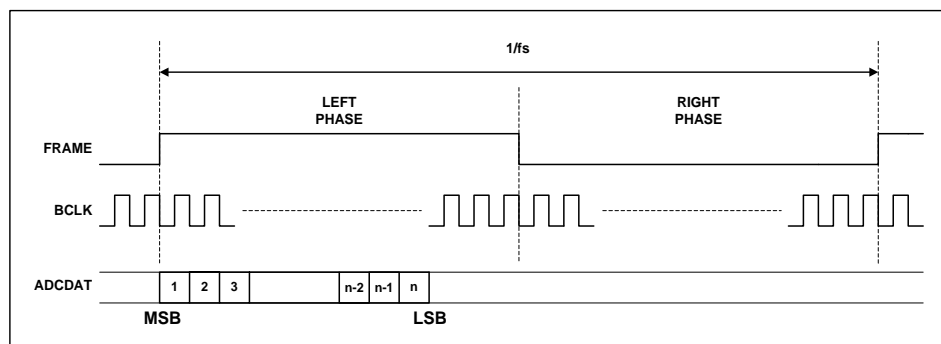
All of these modes are MSB first. They are described in Audio Data Formats, below. Refer to the Electrical Characteristic section for timing information.

### MASTER AND SLAVE MODE OPERATION

The WM8950 audio interface may be configured as either master or slave. As a master interface device the WM8950 generates BCLK and FRAME and thus controls sequencing of the data transfer on ADCDAT. To set the device to master mode register bit MS should be set high. In slave mode (MS=0), the WM8950 responds with data to clocks it receives over the digital audio interfaces.

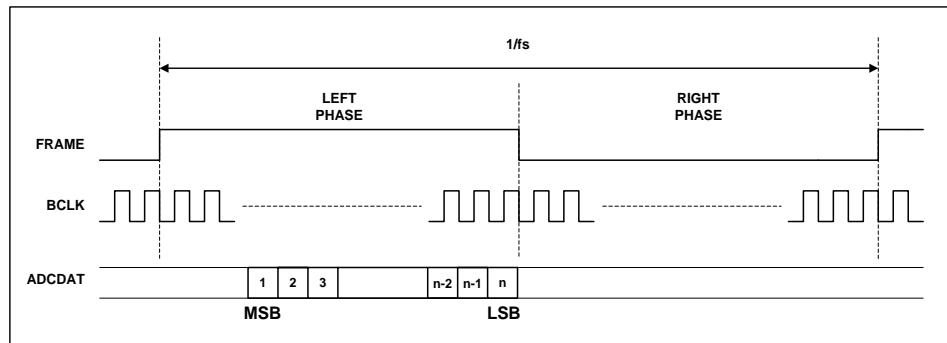
### AUDIO DATA FORMATS

In Left Justified mode, the MSB is available on the first rising edge of BCLK following an FRAME transition. The other bits up to the LSB are then transmitted in order. Depending on word length, BCLK frequency and sample rate, there may be unused BCLK cycles before each FRAME transition.



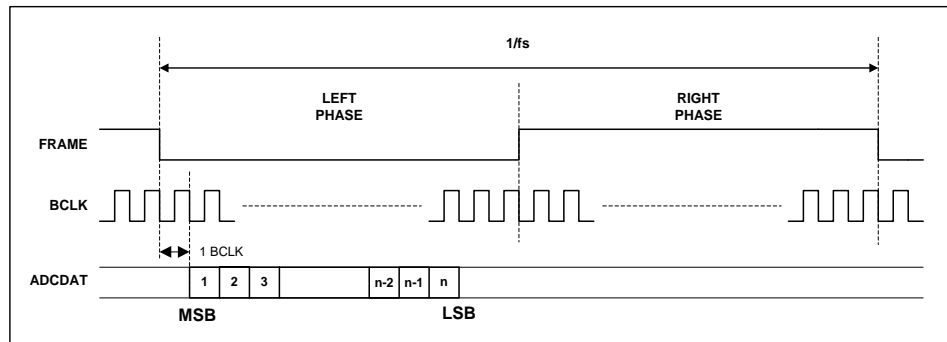
**Figure 19 Left Justified Audio Interface (assuming n-bit word length)**

In Right Justified mode, the LSB is available on the last rising edge of BCLK before a FRAME transition. All other bits are transmitted before (MSB first). Depending on word length, BCLK frequency and sample rate, there may be unused BCLK cycles after each FRAME transition.



**Figure 20 Right Justified Audio Interface (assuming n-bit word length)**

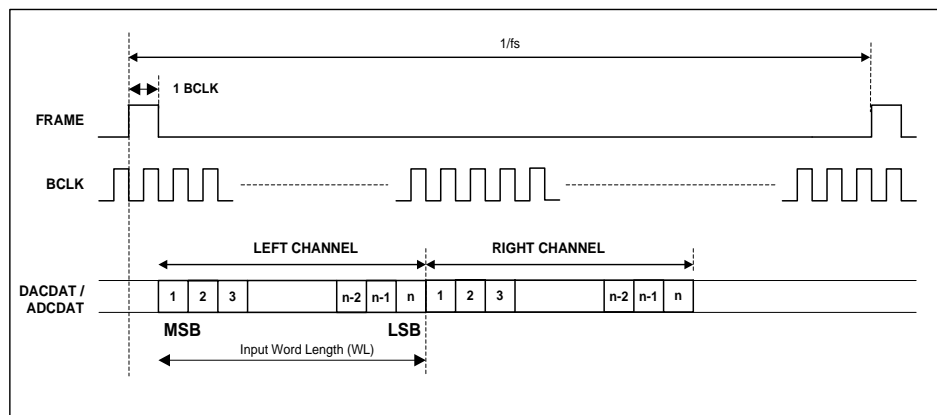
In I<sup>2</sup>S mode, the MSB is available on the second rising edge of BCLK following a FRAME transition. The other bits up to the LSB are then transmitted in order. Depending on word length, BCLK frequency and sample rate, there may be unused BCLK cycles between the LSB of one sample and the MSB of the next.



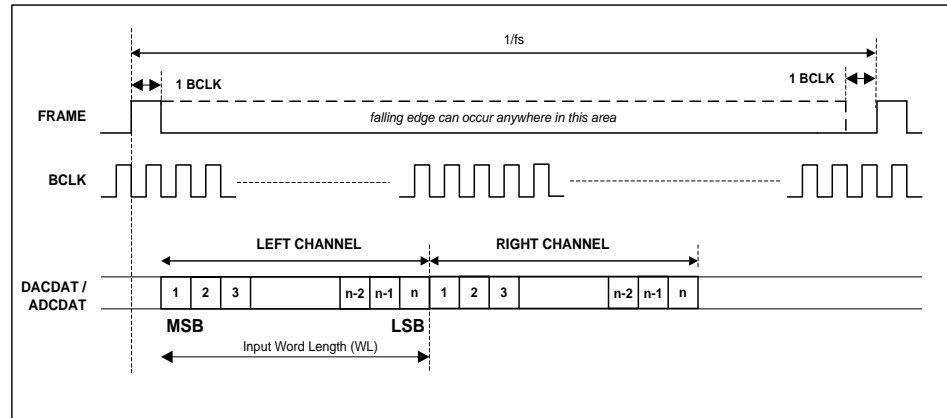
**Figure 21 I<sup>2</sup>S Audio Interface (assuming n-bit word length)**

In DSP/PCM mode, the left channel MSB is available on the 2<sup>nd</sup> (mode A) rising edge of BCLK following a rising edge of FRAME. Right channel data immediately follows left channel data. Depending on word length, BCLK frequency and sample rate, there may be unused BCLK cycles between the LSB of the right channel data and the next sample.

In device master mode, the LRC output will resemble the frame pulse shown in Figure 22. In device slave mode, Figure 23 it is possible to use any length of frame pulse less than 1/fs, providing the falling edge of the frame pulse occurs greater than one BCLK period before the rising edge of the next frame pulse.



**Figure 22 DSP/PCM Mode Audio Interface (mode A, LRP=0, Master)**



**Figure 23 DSP/PCM Mode Audio Interface (mode A, LRP=0, Slave)**

When using ADCLRSWAP = 1 in DSP/PCM mode, the data will appear in the Right Phase of the FRAME, which will be 16/20/24/32 bits after the FRAME pulse.

REGISTER ADDRESS	BIT	LABEL	DEFAULT	DESCRIPTION
R4 Audio interface control	1	ADCLRSWAP	0	Controls whether ADC data appears in 'right' or 'left' phases of FRAME clock: 0=ADC data appear in 'left' phase of FRAME 1=ADC data appears in 'right' phase of FRAME
	4:3	FMT	10	Audio interface Data Format Select: 00=Right Justified 01=Left Justified 10=l <sup>2</sup> S format 11= DSP/PCM mode
	6:5	WL	10	Word length 00=16 bits 01=20 bits 10=24 bits 11=32 bits (see note)
	7	FRAMEP	0	Frame clock polarity 0=normal 1=inverted
	8	BCP	0	BCLK polarity 0=normal 1=inverted
				DSP Mode – reserved

**Table 31 Audio Interface Control**

**AUDIO INTERFACE CONTROL**

The register bits controlling audio format, word length and master / slave mode are summarised below. Each audio interface can be controlled individually.

Register bit MS selects audio interface operation in master or slave mode. In Master mode BCLK, and FRAME are outputs. The frequency of BCLK and FRAME in master mode are controlled with BCLKDIV. These are divided down versions of master clock. This may result in short BCLK pulses at the end of a frame if there is a non-integer ratio of BCLKs to FRAME clocks.

REGISTER ADDRESS	BIT	LABEL	DEFAULT	DESCRIPTION
R6 Clock generation control	0	MS	0	Sets the chip to be master over FRAME and BCLK 0=BCLK and FRAME clock are inputs 1=BCLK and FRAME clock are outputs generated by the WM8950 (MASTER)
	4:2	BCLKDIV	000	Configures the BCLK and FRAME output frequency, for use when the chip is master over BCLK. 000=divide by 1 (BCLK=MCLK) 001=divide by 2 (BCLK=MCLK/2) 010=divide by 4 011=divide by 8 100=divide by 16 101=divide by 32 110=reserved 111=reserved
	7:5	MCLKDIV	010	Sets the scaling for either the MCLK or PLL clock output (under control of CLKSEL) 000=divide by 1 001=divide by 1.5 010=divide by 2 011=divide by 3 100=divide by 4 101=divide by 6 110=divide by 8 111=divide by 12
	8	CLKSEL	1	Controls the source of the clock for all internal operation: 0=MCLK 1=PLL output

**Table 32 Clock Control**
**COMPANDING**

The WM8950 supports A-law and  $\mu$ -law companding. Companding can be enabled on the ADC audio interface by writing the appropriate value to the ADC\_COMP register bit.

REGISTER ADDRESS	BIT	LABEL	DEFAULT	DESCRIPTION
R5 Companding control	2:1	ADC_COMP	0	ADC companding 00=off 01=reserved 10= $\mu$ -law 11=A-law

**Table 33 Companding Control**

Companding involves using a piecewise linear approximation of the following equations (as set out by ITU-T G.711 standard) for data compression:

$\mu$ -law (where  $\mu=255$  for the U.S. and Japan):

$$F(x) = \ln(1 + \mu|x|) / \ln(1 + \mu) \quad \} -1 \leq x \leq 1$$

A-law (where  $A=87.6$  for Europe):

$$F(x) = A|x| / (1 + \ln A) \quad \} \text{ for } x \leq 1/A$$

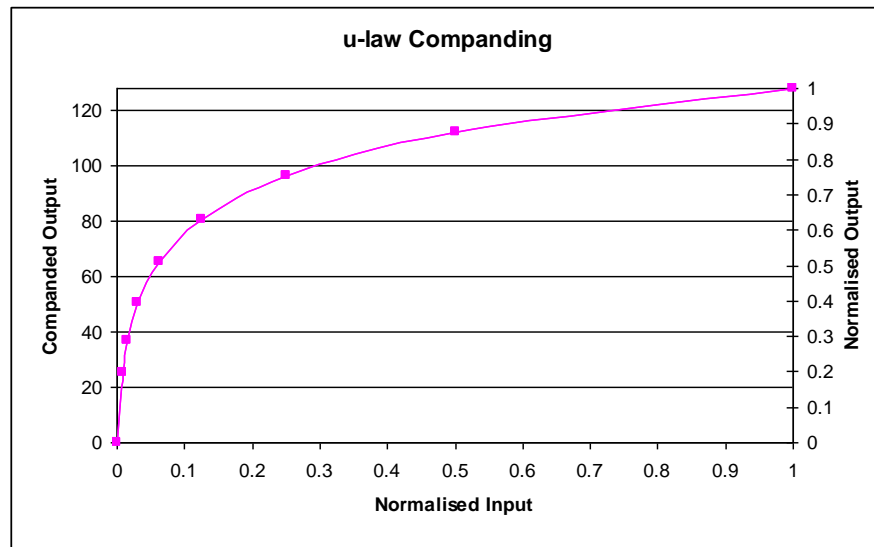
$$F(x) = (1 + \ln A|x|) / (1 + \ln A) \quad \} \text{ for } 1/A \leq x \leq 1$$

The companded data is also inverted as recommended by the G.711 standard (all 8 bits are inverted for  $\mu$ -law, all even data bits are inverted for A-law). The data will be transmitted as the first 8 MSB's of data.

Companding converts 13 bits ( $\mu$ -law) or 12 bits (A-law) to 8 bits using non-linear quantization. The input data range is separated into 8 levels, allowing low amplitude signals better precision than that of high amplitude signals. This is to exploit the operation of the human auditory system, where louder sounds do not require as much resolution as quieter sounds. The companded signal is an 8-bit word containing sign (1-bit), exponent (3-bits) and mantissa (4-bits).

BIT7	BIT[6:4]	BIT[3:0]
SIGN	EXPONENT	MANTISSA

**Table 34 8-bit Companded Word Composition**



**Figure 24 u-Law Companding**



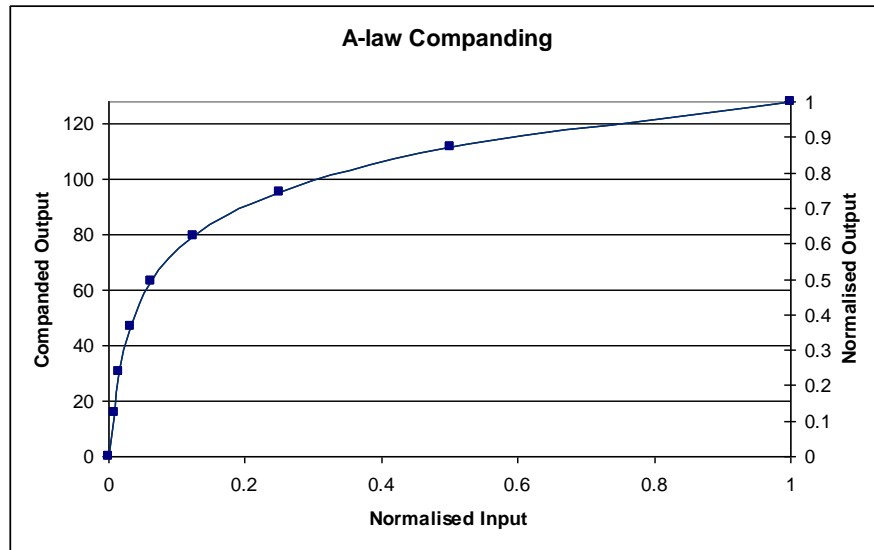


Figure 25 A-Law Comping

## AUDIO SAMPLE RATES

The WM8950 sample rate for the ADC is set using the SR register bits. The cut-offs for the digital filters and the ALC attack/decay times stated are determined using these values and assume a 256fs master clock rate.

If a sample rate that is not explicitly supported by the SR register settings is required then the closest SR value to that sample rate should be chosen, the filter characteristics and the ALC attack, decay and hold times will scale appropriately.

REGISTER ADDRESS	BIT	LABEL	DEFAULT	DESCRIPTION
R7 Additional control	3:1	SR	000	Approximate sample rate (configures the coefficients for the internal digital filters): 000=48kHz 001=32kHz 010=24kHz 011=16kHz 100=12kHz 101=8kHz 110-111=reserved

Table 35 Sample Rate Control

**MASTER CLOCK AND PHASE LOCKED LOOP (PLL)**

The WM8950 has an on-chip phase-locked loop (PLL) circuit that can be used to:

Generate master clocks for the WM8950 audio functions from another external clock, e.g. in telecoms applications.

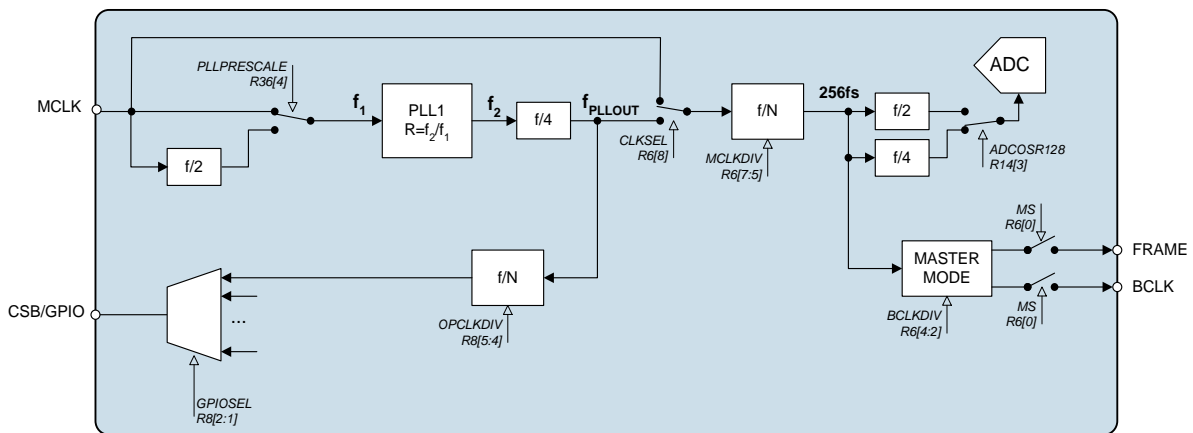
Generate and output (on pin CSB/GPIO) a clock for another part of the system that is derived from an existing audio master clock.

Figure 26 shows the PLL and internal clocking arrangement on the WM8950.

The PLL can be enabled or disabled by the PLEN register bit.

REGISTER ADDRESS	BIT	LABEL	DEFAULT	DESCRIPTION
R1 Power management 1	5	PLEN	0	PLL enable 0=PLL off 1=PLL on

**Table 36 PLEN Control Bit**



**Figure 26 PLL and Clock Select Circuit**

The PLL frequency ratio  $R = f_2/f_1$  (see Figure 26) can be set using the register bits PLLK and PLLN:

$$PLLN = \text{int } R$$

$$PLLK = \text{int } (2^{24} (R - PLLN))$$

**EXAMPLE:**

MCLK=12MHz, required clock = 12.288MHz.

R should be chosen to ensure  $5 < PLLN < 13$ . There is a fixed divide by 4 in the PLL and a selectable divide by N after the PLL which should be set to divide by 2 to meet this requirement.

Enabling the divide by 2 sets the required  $f_2 = 4 \times 2 \times 12.288\text{MHz} = 98.304\text{MHz}$ .

$$R = 98.304 / 12 = 8.192$$

$$PLLN = \text{int } R = 8$$

$$k = \text{int } (2^{24} \times (8.192 - 8)) = 3221225 = 3126\text{E9h}$$

REGISTER ADDRESS	BIT	LABEL	DEFAULT	DESCRIPTION
R36 PLL N value	4	PLLPRESCALE	0	0 = MCLK input not divided (default) 1 = Divide MCLK by 2 before input to PLL
	3:0	PLLN	1000	Integer (N) part of PLL input/output frequency ratio. Use values greater than 5 and less than 13.
R37 PLL K value 1	5:0	PLLK [23:18]	0Ch	Fractional (K) part of PLL1 input/output frequency ratio (treat as one 24-digit binary number).
R38 PLL K Value 2	8:0	PLLK [17:9]	093h	
R39 PLL K Value 3	8:0	PLLK [8:0]	0E9h	

**Table 37 PLL Frequency Ratio Control**

The PLL performs best when  $f_2$  is around 90MHz. Its stability peaks at N=8. Some example settings are shown in Figure 35.

MCLK (MHz) (F1)	DESIRED OUTPUT (MHz)	F2 (MHz)	PRESCALE DIVIDE	POSTSCALE DIVIDE	R	N (Hex)	K (Hex)
12	11.2896	90.3168	1	2	7.5264	7	86C220
12	12.288	98.304	1	2	8.192	8	3126E8
13	11.2896	90.3168	1	2	6.947446	6	F28BD4
13	12.288	98.304	1	2	7.561846	7	8FD525
14.4	11.2896	90.3168	1	2	6.272	6	45A1CA
14.4	12.288	98.304	1	2	6.826667	6	D3A06E
19.2	11.2896	90.3168	2	2	9.408	9	6872AF
19.2	12.288	98.304	2	2	10.24	A	3D70A3
19.68	11.2896	90.3168	2	2	9.178537	9	2DB492
19.68	12.288	98.304	2	2	9.990243	9	FD809F
19.8	11.2896	90.3168	2	2	9.122909	9	1F76F7
19.8	12.288	98.304	2	2	9.929697	9	EE009E
24	11.2896	90.3168	2	2	7.5264	7	86C226
24	12.288	98.304	2	2	8.192	8	3126E8
26	11.2896	90.3168	2	2	6.947446	6	F28BD4
26	12.288	98.304	2	2	7.561846	7	8FD525
27	11.2896	90.3168	2	2	6.690133	6	BOAC93
27	12.288	98.304	2	2	7.281778	7	482296

**Table 38 PLL Frequency Examples**

## GENERAL PURPOSE INPUT/OUTPUT

The CSB/GPIO pin can be configured to perform a variety of useful tasks by setting the GPIOSEL register bits. The GPIO is only available in 2 wire mode.

REGISTER ADDRESS	BIT	LABEL	DEFAULT	DESCRIPTION
R8 GPIO control	2:0	GPIOSEL	000	CSB/GPIO pin function select: 000=CSB input 001=Reserved 010=Temp ok 011=Automute active 100=PLL clk o/p 101=PLL lock 110=Reserved 111=Reserved
	3	GPIOPOL	0	GPIO Polarity invert 0=Non inverted 1=Inverted
	5:4	OPCLKDIV	00	PLL Output clock division ratio 00=divide by 1 01=divide by 2 10=divide by 3 11=divide by 4

Table 39 CSB/GPIO Control

## CONTROL INTERFACE

### SELECTION OF CONTROL MODE AND 2-WIRE MODE ADDRESS

The control interface can operate as either a 3-wire or 2-wire MPU interface. The MODE pin determines the 2 or 3 wire mode as shown in Table 40.

The WM8950 is controlled by writing to registers through a serial control interface. A control word consists of 16 bits. The first 7 bits (B15 to B9) are address bits that select which control register is accessed. The remaining 9 bits (B8 to B0) are register bits, corresponding to the 9 bits in each control register.

MODE	INTERFACE FORMAT
Low	2 wire
High	3 wire

Table 40 Control Interface Mode Selection

### 3-WIRE SERIAL CONTROL MODE

In 3-wire mode, every rising edge of SCLK clocks in one data bit from the SDIN pin. A rising edge on CSB/GPIO latches in a complete control word consisting of the last 16 bits.

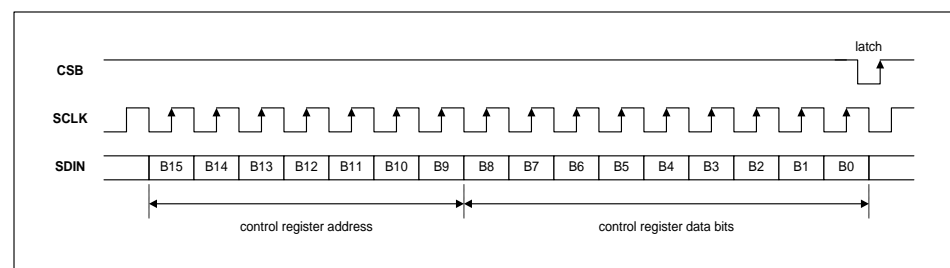


Figure 27 3-Wire Serial Control Interface

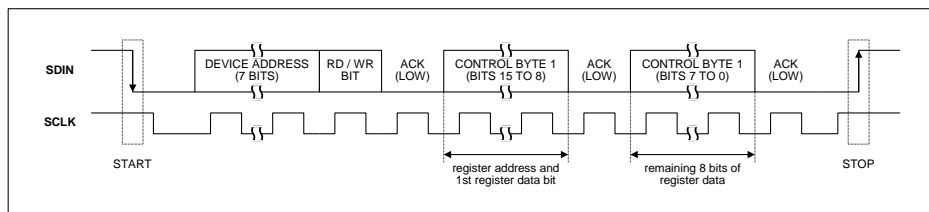
## 2-WIRE SERIAL CONTROL MODE

The WM8950 supports software control via a 2-wire serial bus. Many devices can be controlled by the same bus, and each device has a unique 7-bit device address (this is not the same as the 7-bit address of each register in the WM8950).

The WM8950 operates as a slave device only. The controller indicates the start of data transfer with a high to low transition on SDIN while SCLK remains high. This indicates that a device address and data will follow. All devices on the 2-wire bus respond to the start condition and shift in the next eight bits on SDIN (7-bit address + Read/Write bit, MSB first). If the device address received matches the address of the WM8950, then the WM8950 responds by pulling SDIN low on the next clock pulse (ACK). If the address is not recognised or the R/W bit is '1' when operating in write only mode, the WM8950 returns to the idle condition and wait for a new start condition and valid address.

During a write, once the WM8950 has acknowledged a correct address, the controller sends the first byte of control data (B15 to B8, i.e. the WM8950 register address plus the first bit of register data). The WM8950 then acknowledges the first data byte by pulling SDIN low for one clock pulse. The controller then sends the second byte of control data (B7 to B0, i.e. the remaining 8 bits of register data), and the WM8950 acknowledges again by pulling SDIN low.

Transfers are complete when there is a low to high transition on SDIN while SCLK is high. After a complete sequence the WM8950 returns to the idle state and waits for another start condition. If a start or stop condition is detected out of sequence at any point during data transfer (i.e. SDIN changes while SCLK is high), the device jumps to the idle condition.



**Figure 28 2-Wire Serial Control Interface**

In 2-wire mode the WM8950 has a fixed device address, 0011010.

## RESETTING THE CHIP

The WM8950 can be reset by performing a write of any value to the software reset register (address 0 hex). This will cause all register values to be reset to their default values. In addition to this there is a Power-On Reset (POR) circuit which ensures that the registers are set to default when the device is powered up.

## POWER SUPPLIES

The WM8950 can use up to three separate power supplies:

**AVDD, AVDD2, AGND and AGND2:** Analogue supply, powers all analogue functions. AVDD can range from 2.5V to 3.6V and has the most significant impact on overall power consumption. A large AVDD slightly improves audio quality.

**DCVDD:** Digital core supply, powers all digital functions except the audio and control interfaces. DCVDD can range from 1.71V to 3.6V, and has no effect on audio quality. The return path for DCVDD is DGND, which is shared with DBVDD.

**DBVDD** Can range from 1.71V to 3.6V. DBVDD return path is through DGND.

It is possible to use the same supply voltage for all supplies. However, digital and analogue supplies should be routed and decoupled separately on the PCB to keep digital switching noise out of the analogue signal paths.

## ADC POWER UP/DOWN SEQUENCE

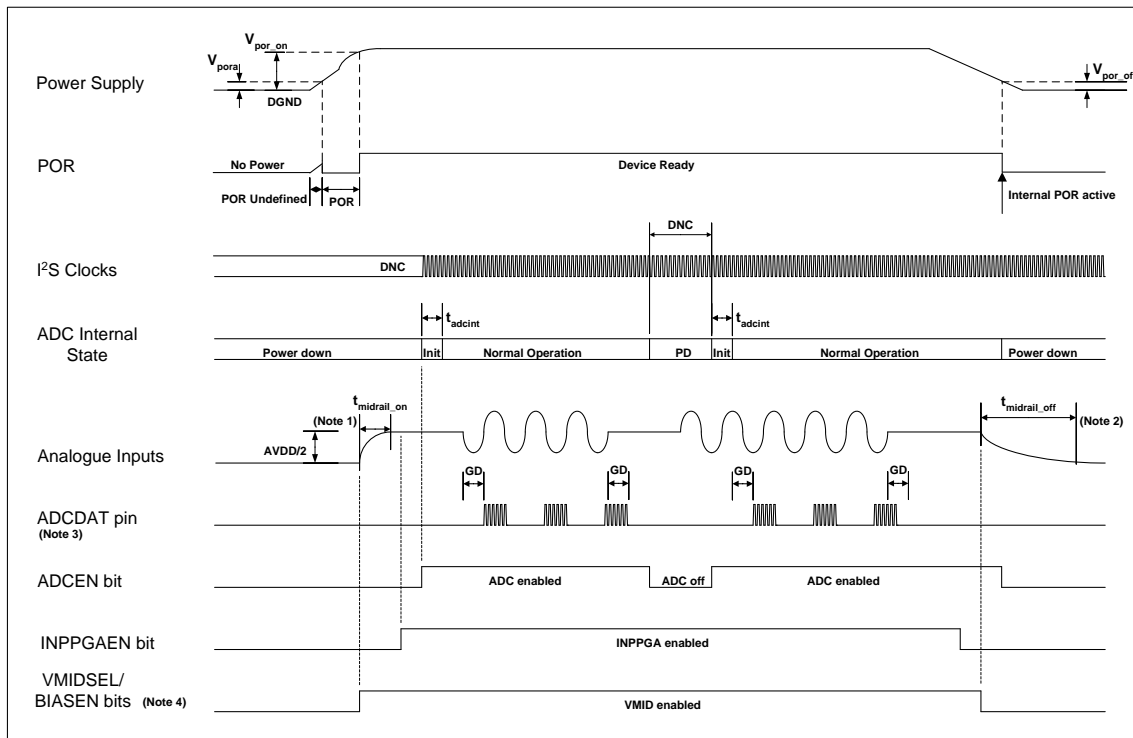


Figure 29 ADC Power Up and Down Sequence (not to scale)

SYMBOL	MIN	TYPICAL	MAX	UNIT
t <sub>midrail_on</sub>		500		ms
t <sub>midrail_off</sub>		>10		s
t <sub>adcint</sub>		2/fs		n/fs

Table 41 Typical POR Operation (typical values, not tested)

Notes:

1. The analogue input pin charge time,  $t_{\text{midrail\_on}}$ , is determined by the VMID pin charge time. This time is dependent upon the value of VMID decoupling capacitor and VMID pin input resistance and AVDD power supply rise time.
2. The analogue input pin discharge time,  $t_{\text{midrail\_off}}$ , is determined by the analogue input coupling capacitor discharge time. The time,  $t_{\text{midrail\_off}}$ , is measured using a 1 $\mu$ F capacitor on the analogue input but will vary dependent upon the value of input coupling capacitor.
3. While the ADC is enabled there will be LSB data bit activity on the ADCDAT pin due to system noise but no significant digital output will be present.
4. The VMIDSEL and BIASEN bits must be set to enable analogue input midrail voltage and for normal ADC operation.
5. ADCDAT data output delay from power up - with power supplies starting from 0V - is determined primarily by the VMID charge time. ADC initialisation and power management bits may be set immediately after POR is released; VMID charge time will be significantly longer and will dictate when the device is stabilised for analogue input.
6. ADCDAT data output delay at power up from device standby (power supplies already applied) is determined by ADC initialisation time,  $2/f_s$ .

## POWER MANAGEMENT

### SAVING POWER BY REDUCING OVERSAMPLING RATE

The default mode of operation of the ADC digital filters is in 64x oversampling mode. Under the control of ADCOSR the oversampling rate may be doubled. 64x oversampling results in a slight decrease in noise performance compared to 128x but lowers the power consumption of the device.

REGISTER ADDRESS	BIT	LABEL	DEFAULT	DESCRIPTION
R14 ADC control	3	ADCOSR128	0	ADC oversample rate select 0 = 64x (lowest power) 1 = 128x (best SNR)

**Table 42 ADC Oversampling Rate Selection**

### VMID

The analogue circuitry will not work unless VMID is enabled (VMIDSEL $\neq$ 00). The impedance of the VMID resistor string, together with the decoupling capacitor on the VMID pin will determine the start-up time of the VMID circuit.

REGISTER ADDRESS	BIT	LABEL	DEFAULT	DESCRIPTION
R1 Power management 1	1:0	VMIDSEL	00	Reference string impedance to VMID pin (determines start-up time): 00=off (open circuit) 01=50k $\Omega$ 10=500k $\Omega$ 11=5k $\Omega$ (for fastest start-up)

**Table 43 VMID Impedance Control**

### BIASEN

REGISTER ADDRESS	BIT	LABEL	DEFAULT	DESCRIPTION
R1 Power management 1	3	BIASEN	0	Analogue amplifier bias control

**Table 44 BIASEN Control**

**ESTIMATED SUPPLY CURRENTS**

When the ADC is enabled it is estimated that approximately 4mA will be drawn from DCVDD when DCVDD=1.8V and fs=48kHz. (This will be lower at lower sample rates). When the PLL is enabled an additional 700 microamps will be drawn from DCVDD.

Table 59 shows the estimated 3.3V AVDD current drawn by various circuits, by register bit.

REGISTER BIT	AVDD CURRENT (MILLIAMPS)
PLLEN	1.4 (with clocks applied)
MICBEN	0.5
BIASEN	0.3
BUFIOEN	0.1
VMIDSEL	10K=>0.3, less than 0.1 for 50k/500k
INPPGAEN	0.2
ADCEN	x64 (ADCOSR=0)=>2.6, x128 (ADCOSR=1)=>4.9

**Table 45 AVDD Supply Current**



**REGISTER MAP**

ADDR B[15:9]		REGISTER NAME	B8	B7	B6	B5	B4	B3	B2	B1	B0	DEF'T VAL	
DEC	HEX											(HEX)	
0	00	Software Reset	Software reset										
1	01	Power manage't 1	0	0	AUXEN	PLLEN	MICBEN	BIASEN	BUFIOEN	VMIDSEL		000	
2	02	Power manage't 2	0	0	0	0	BOOSTEN	0	INPPGAEN	0	ADCEN	000	
4	04	Audio Interface	BCP	FRAMEP	WL		FMT		0	ALRSWAP	0	050	
5	05	Companding ctrl	0	0	0	0	0		ADC_COMP		0	000	
6	06	Clock Gen ctrl	CLKSEL	MCLKDIV			BCLKDIV			0	MS	140	
7	07	Additional ctrl	0	0	0	0	0	SR			SLOWCLK EN	000	
8	08	GPIO Stuff	0	0	0	OPCLKDIV		GPIOPOL	GPIOSEL			000	
14	0E	ADC Control	HPFEN	HPFAPP	HPFCUT			ADCOSR 128	0	0	ADCPOL	100	
15	0F	ADC Digital Vol	0	ADCVOL								0FF	
18	12	EQ1 – low shelf	0	0	EQ1C		EQ1G				12C		
19	13	EQ2 – peak 1	EQ2BW	0	EQ2C		EQ2G				02C		
20	14	EQ3 – peak 2	EQ3BW	0	EQ3C		EQ3G				02C		
21	15	EQ4 – peak 3	EQ4BW	0	EQ4C		EQ4G				02C		
22	16	EQ5 – high shelf	0	0	EQ5C		EQ5G				02C		
27	1B	Notch Filter 1	NFU	NFEN	NFA0[13:7]							000	
28	1C	Notch Filter 2	NFU	0	NFA0[6:0]							000	
29	1D	Notch Filter 3	NFU	0	NFA1[13:7]							000	
30	1E	Notch Filter 4	NFU	0	NFA1[6:0]							000	
32	20	ALC control 1	ALCSEL	0	0	ALCMAX			ALCMIN			038	
33	21	ALC control 2	ALCZC	ALCHLD				ALCLVL				00B	
34	22	ALC control 3	ALCMODE	ALCDCY				ALCATK				032	
35	23	Noise Gate	0	0	0	0	0	NGEN	NGTH			000	
36	24	PLL N	0	0	0	0	PLL_PRE SCALE	PLLN[3:0]			008		
37	25	PLL K 1	0	0	0	PLLK[23:18]						00C	
38	26	PLL K 2	PLLK[17:9]									093	
39	27	PLL K 3	PLLK[8:0]									0E9	
44	2C	Input ctrl	MBVSEL	0	0	0	0	AUXMODE	AUX2 INPPGA	MICN2 INPPGA	MICP2 INPPGA	003	
45	2D	INP PGA gain ctrl	0	INPPGAZC	INPPGA MUTE	INPPGAVOL						010	
47	2F	ADC Boost ctrl	PGABOOST	0	MICP2BOOSTVOL			0	AUX2BOOSTVOL			100	
49	31	Thermal Shutdown	0	0	0	0	0	0	0	TSDEN	0	002	

## DIGITAL FILTER CHARACTERISTICS

PARAMETER	TEST CONDITIONS	MIN	TYP	MAX	UNIT
<b>ADC Filter</b>					
Passband	+/- 0.025dB	0		0.454fs	
	-6dB		0.5fs		
Passband Ripple				+/- 0.025	dB
Stopband		0.546fs			
Stopband Attenuation	f > 0.546fs	-60			dB
Group Delay			21/fs		
<b>ADC High-Pass Filter</b>					
High-Pass Filter Corner Frequency	-3dB		3.7		Hz
	-0.5dB		10.4		
	-0.1dB		21.6		

**Table 46 Digital Filter Characteristics**

## TERMINOLOGY

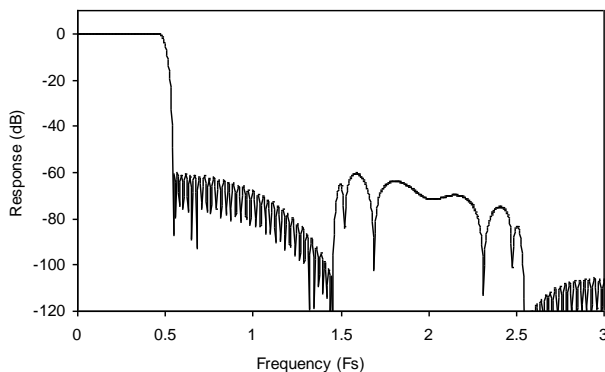
1. Stop Band Attenuation (dB) – the degree to which the frequency spectrum is attenuated (outside audio band)
2. Pass-band Ripple – any variation of the frequency response in the pass-band region
3. Note that this delay applies only to the filters and does not include additional delays through other digital circuits. See Table 47 for the total delay.

PARAMETER	TEST CONDITIONS	MIN	TYP	MAX	UNIT
<b>ADC Path Group Delay</b>					
Total Delay (ADC analogue input to digital audio interface output)	EQ disabled	26/fs	28/fs	30/fs	
	EQ enabled	27/fs	29/fs	31/fs	

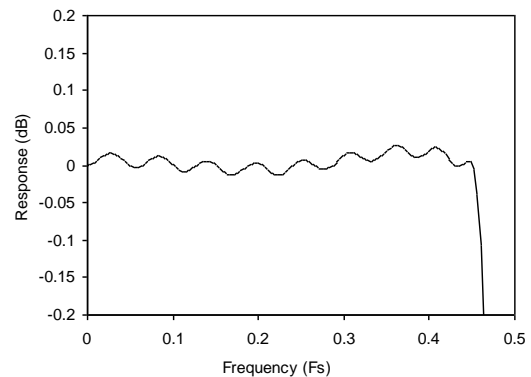
**Table 47 Total Group Delay**

**Note:** Wind noise filter is disabled.

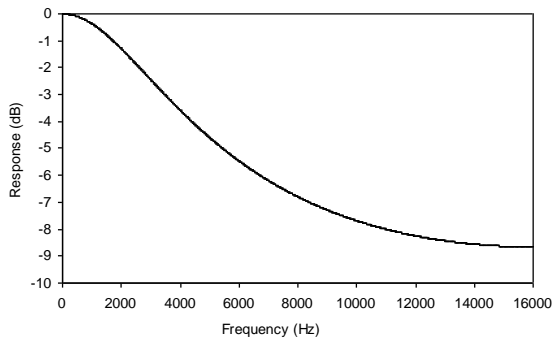
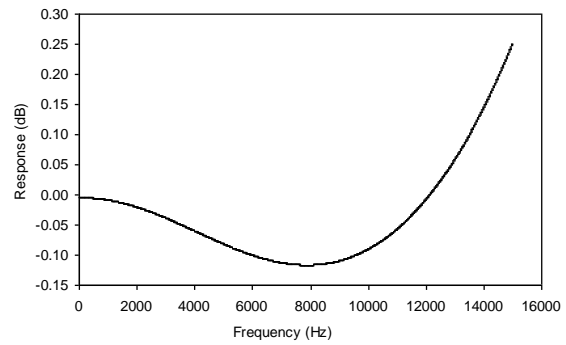
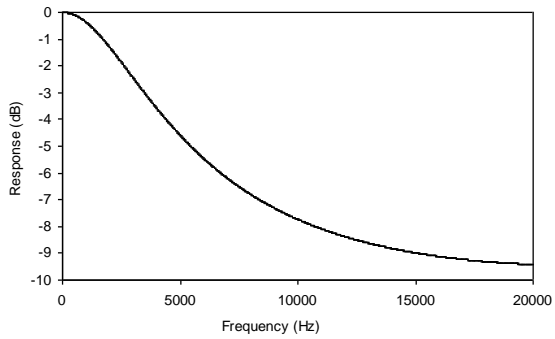
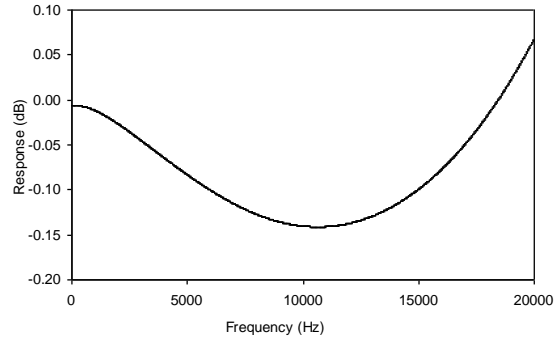
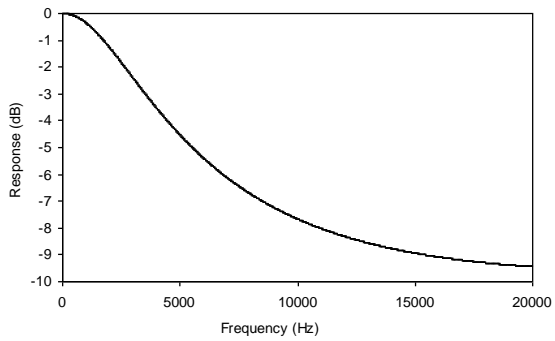
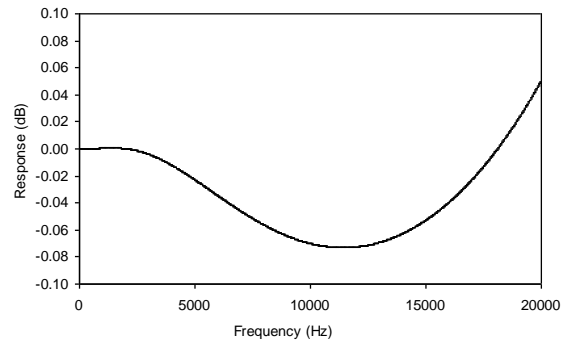
## ADC FILTER RESPONSES



**Figure 30 ADC Digital Filter Frequency Response**

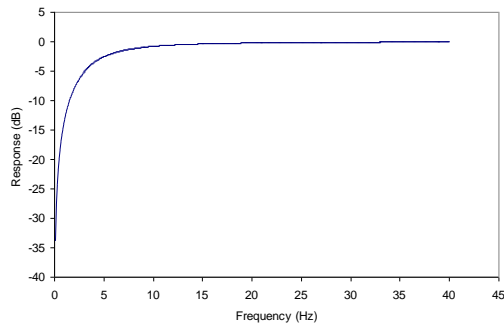


**Figure 31 ADC Digital Filter Ripple**

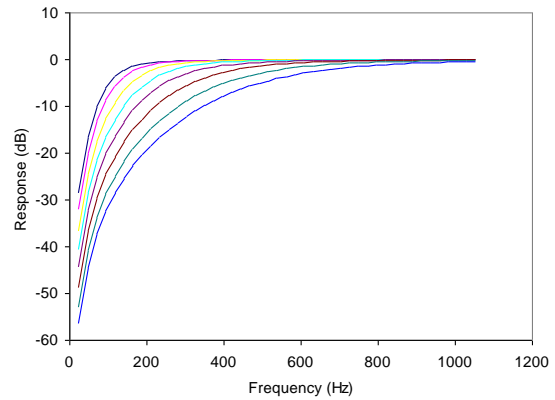
**DE-EMPHASIS FILTER RESPONSES**

**Figure 32 De-emphasis Frequency Response (32kHz)**

**Figure 33 De-emphasis Error (32kHz)**

**Figure 34 De-emphasis Frequency Response (44.1kHz)**

**Figure 35 De-emphasis Error (44.1kHz)**

**Figure 36 De-emphasis Frequency Response (48kHz)**

**Figure 37 De-emphasis Error (48kHz)**

**HIGH-PASS FILTER**

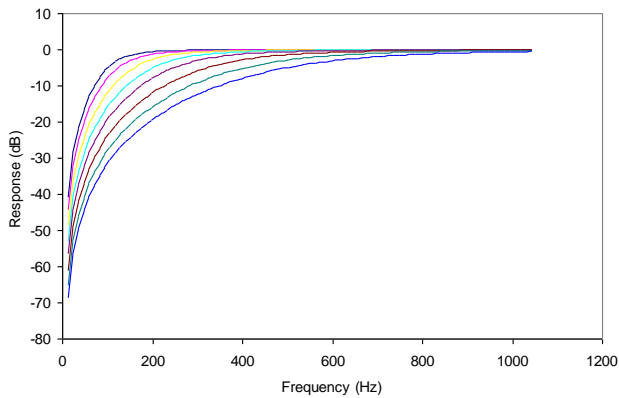
The WM8950 has a selectable digital high-pass filter in the ADC filter path. This filter has two modes, audio and applications. In audio mode the filter is a 1<sup>st</sup> order IIR with a cut-off of around 3.7Hz. In applications mode the filter is a 2<sup>nd</sup> order high-pass filter with a selectable cut-off frequency.



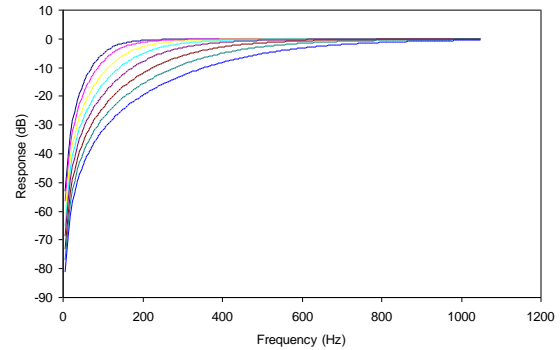
**Figure 38 ADC High-pass Filter Response, HPFAPP=0**



**Figure 39 ADC High-pass Filter Responses (48kHz), HPFAPP=1, all cut-off settings shown.**



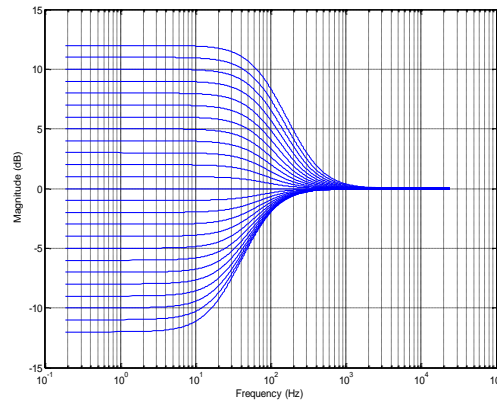
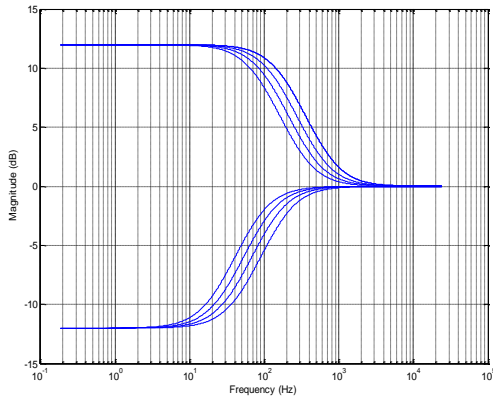
**Figure 40 ADC High-pass Filter Responses (24kHz), HPFAPP=1, all cut-off settings shown.**



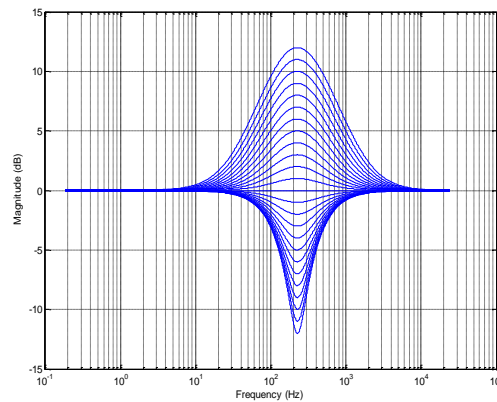
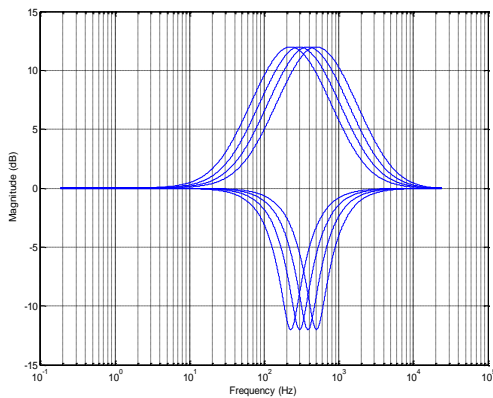
**Figure 41 ADC High-pass Filter Responses (12kHz), HPFAPP=1, all cut-off settings shown.**

**5-BAND EQUALISER**

The WM8950 has a 5-band equaliser which can be applied to the ADC path. The plots from Figure 42 to Figure 55 show the frequency responses of each filter with a sampling frequency of 48kHz, firstly showing the different cut-off/centre frequencies with a gain of  $\pm 12\text{dB}$ , and secondly a sweep of the gain from  $-12\text{dB}$  to  $+12\text{dB}$  for the lowest cut-off/centre frequency of each filter.

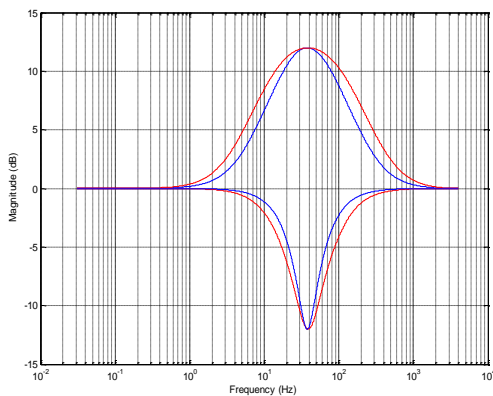


**Figure 42 EQ Band 1 – Low Frequency Shelf Filter Cut-offs** **Figure 43 EQ Band 1 – Gains for Lowest Cut-off Frequency**

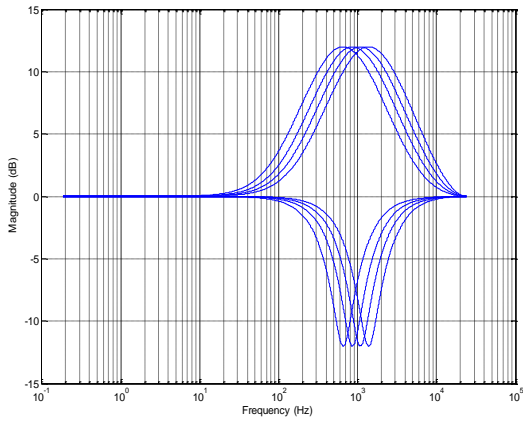


**Figure 44 EQ Band 2 – Peak Filter Centre Frequencies, EQ2BW=0**

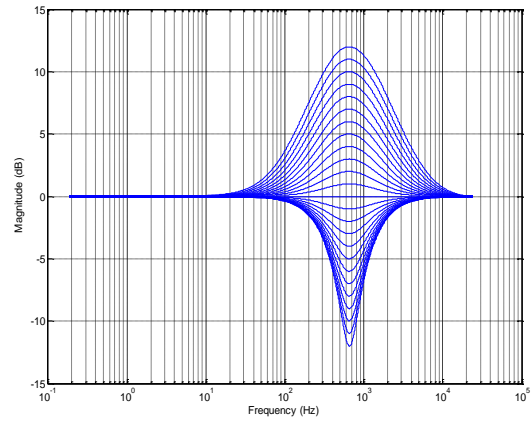
**Figure 45 EQ Band 2 – Peak Filter Gains for Lowest Cut-off Frequency, EQ2BW=0**



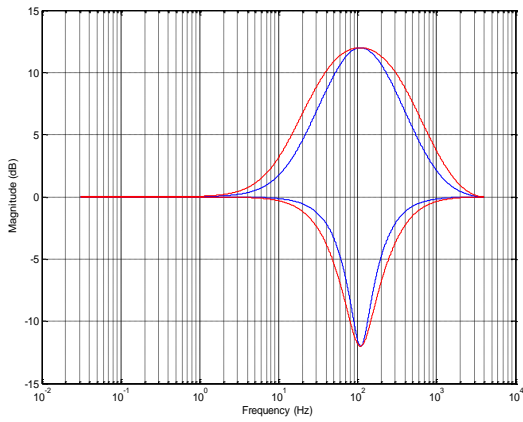
**Figure 46 EQ Band 2 – EQ2BW=0, EQ2BW=1**



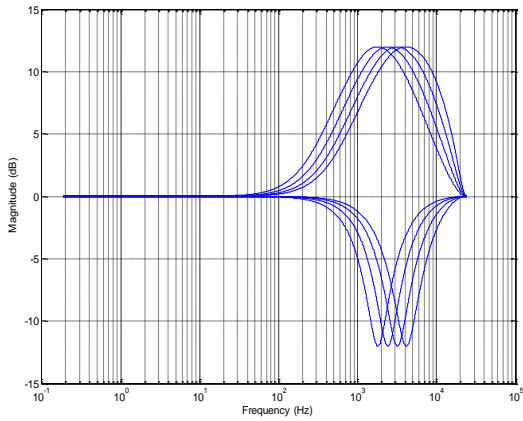
**Figure 47 EQ Band 3 – Peak Filter Centre Frequencies, EQ3BW=0**



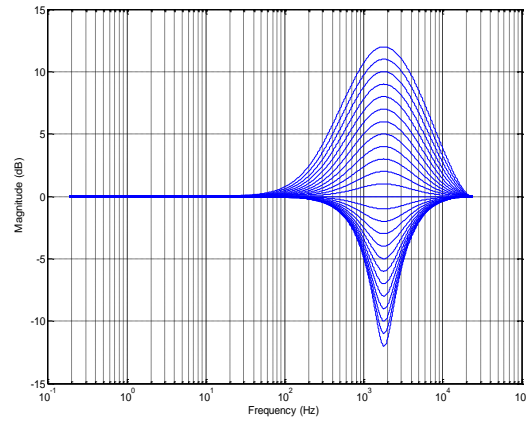
**Figure 48 EQ Band 3 – Peak Filter Gains for Lowest Cut-off Frequency, EQ3BW=0**



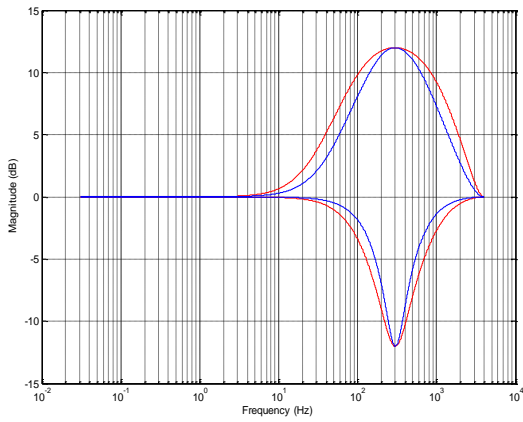
**Figure 49 EQ Band 3 – EQ3BW=0, EQ3BW=1**



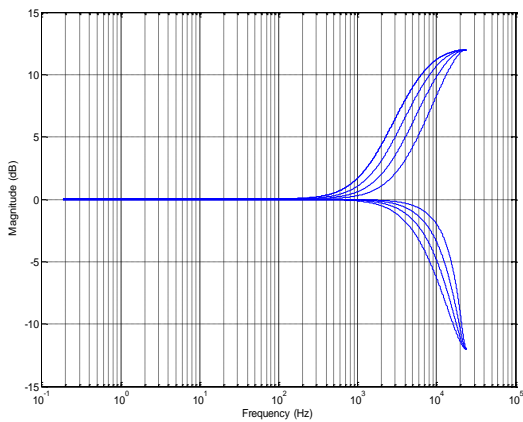
**Figure 50 EQ Band 4 – Peak Filter Centre Frequencies, EQ3BW=0**



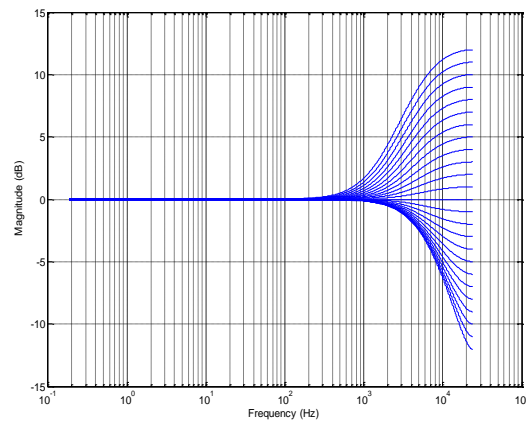
**Figure 51 EQ Band 4 – Peak Filter Gains for Lowest Cut-off Frequency, EQ4BW=0**



**Figure 52 EQ Band 4 – EQ3BW=0, EQ3BW=1**

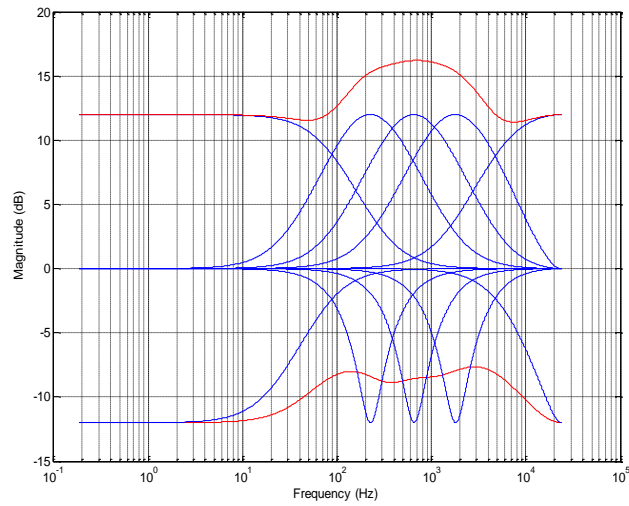


**Figure 53 EQ Band 5 – High Frequency Shelf Filter Cut-offs**



**Figure 54 EQ Band 5 – Gains for Lowest Cut-off Frequency**

Figure 55 shows the result of having the gain set on more than one channel simultaneously. The blue traces show each band (lowest cut-off/centre frequency) with  $\pm 12\text{dB}$  gain. The red traces show the cumulative effect of all bands with  $+12\text{dB}$  gain and all bands  $-12\text{dB}$  gain, with EQxBW=0 for the peak filters.

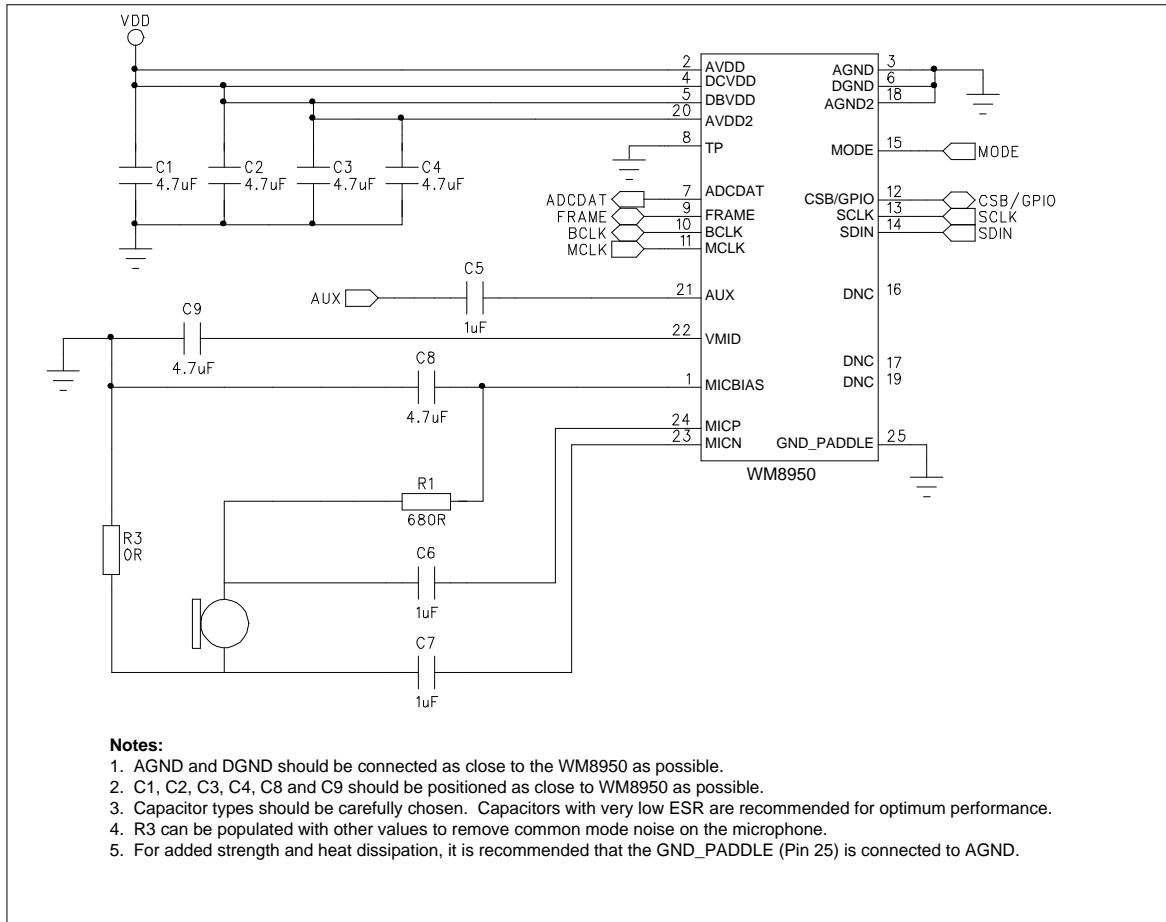


**Figure 55 Cumulative Frequency Boost/Cut**



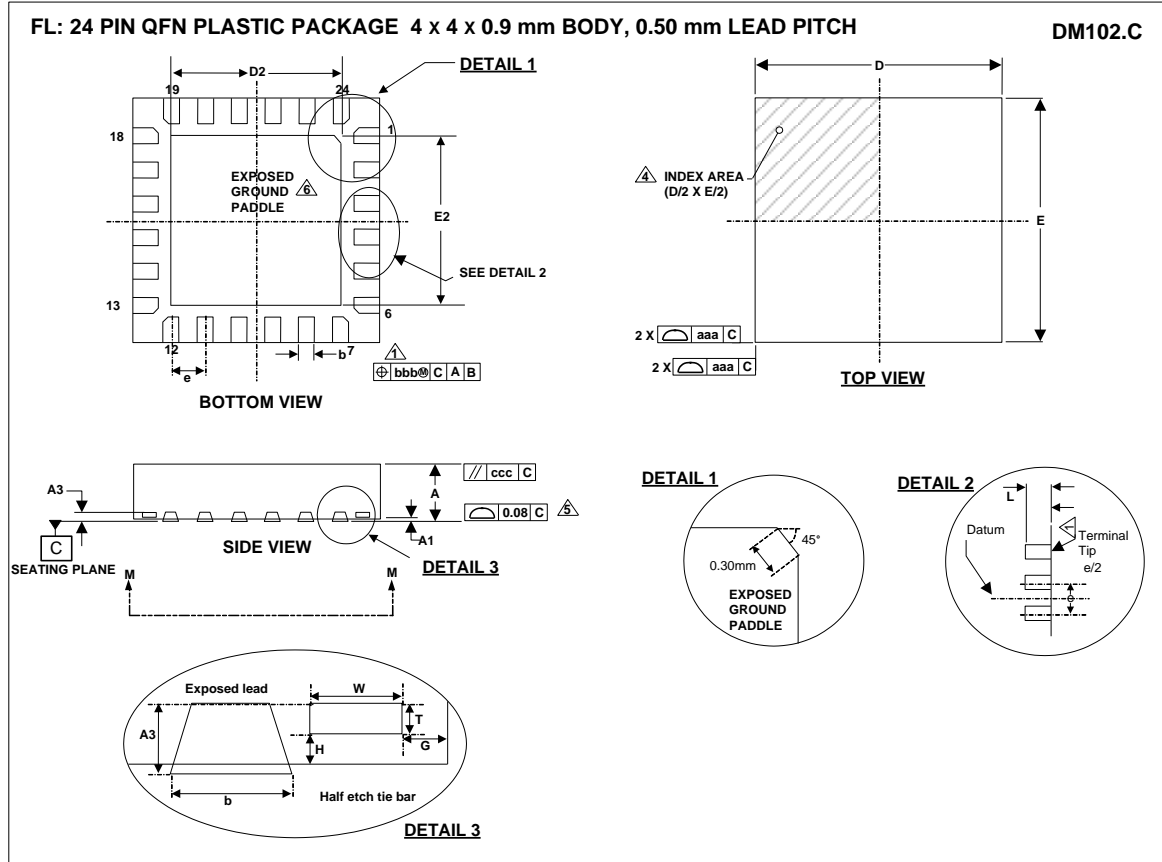
## APPLICATIONS INFORMATION

### RECOMMENDED EXTERNAL COMPONENTS



**Figure 56 Recommended External Components**

## PACKAGE DIAGRAM



Symbols	Dimensions (mm)			
	MIN	NOM	MAX	NOTE
<b>A</b>	0.80	0.85	0.90	
<b>A1</b>	0	0.035	0.05	
<b>A3</b>		0.203 REF		
<b>b</b>	0.20	0.25	0.30	1
<b>D</b>		4.00 BSC		
<b>D2</b>	2.40	2.50	2.60	2
<b>E</b>		4.00 BSC		
<b>E2</b>	2.40	2.50	2.60	2
<b>e</b>		0.50 BSC		
<b>G</b>		0.20		
<b>H</b>		0.10		
<b>L</b>	0.35	0.40	0.45	
<b>T</b>		0.103		
<b>W</b>		0.15		
<b>Tolerances of Form and Position</b>				
<b>aaa</b>		0.10		
<b>bbb</b>		0.10		
<b>ccc</b>		0.10		
<b>REF:</b>	JEDEC, MO-220, VARIATION VGGD-8.			

- NOTES:**
1. DIMENSION **b** APPLIES TO METALLIZED TERMINAL AND IS MEASURED BETWEEN 0.15 mm AND 0.30 mm FROM TERMINAL TIP.
  2. FALLS WITHIN JEDEC, MO-220, VARIATION VGGD-8.
  3. ALL DIMENSIONS ARE IN MILLIMETRES.
  4. THE TERMINAL #1 IDENTIFIER AND TERMINAL NUMBERING CONVENTION SHALL CONFORM TO JEDEC 95-1 SPP-002.
  5. COPLANARITY APPLIES TO THE EXPOSED HEAT SINK SLUG AS WELL AS THE TERMINALS.
  6. REFER TO APPLICATIONS NOTE WAN\_0118 FOR FURTHER INFORMATION REGARDING PCB FOOTPRINTS AND QFN PACKAGE SOLDERING.
  7. THIS DRAWING IS SUBJECT TO CHANGE WITHOUT NOTICE.

---

**IMPORTANT NOTICE**

---

**Contacting Cirrus Logic Support**

For all product questions and inquiries, contact a Cirrus Logic Sales Representative.

To find one nearest you, go to [www.cirrus.com](http://www.cirrus.com).

---

For the purposes of our terms and conditions of sale, "Preliminary" or "Advanced" datasheets are non-final datasheets that include but are not limited to datasheets marked as "Target", "Advance", "Product Preview", "Preliminary Technical Data" and/or "Pre-production." Products provided with any such datasheet are therefore subject to relevant terms and conditions associated with "Preliminary" or "Advanced" designations. The products and services of Cirrus Logic International (UK) Limited; Cirrus Logic, Inc.; and other companies in the Cirrus Logic group (collectively either "Cirrus Logic" or "Cirrus") are sold subject to Cirrus Logic's terms and conditions of sale supplied at the time of order acknowledgment, including those pertaining to warranty, indemnification, and limitation of liability. Software is provided pursuant to applicable license terms. Cirrus Logic reserves the right to make changes to its products and specifications or to discontinue any product or service without notice. Customers should therefore obtain the latest version of relevant information from Cirrus Logic to verify that the information is current and complete. Testing and other quality control techniques are utilized to the extent Cirrus Logic deems necessary. Specific testing of all parameters of each device is not necessarily performed. In order to minimize risks associated with customer applications, the customer must use adequate design and operating safeguards to minimize inherent or procedural hazards. Cirrus Logic is not liable for applications assistance or customer product design. The customer is solely responsible for its selection and use of Cirrus Logic products. Use of Cirrus Logic products may entail a choice between many different modes of operation, some or all of which may require action by the user, and some or all of which may be optional. Nothing in these materials should be interpreted as instructions or suggestions to choose one mode over another. Likewise, description of a single mode should not be interpreted as a suggestion that other modes should not be used or that they would not be suitable for operation. Features and operations described herein are for illustrative purposes only.

CERTAIN APPLICATIONS USING SEMICONDUCTOR PRODUCTS MAY INVOLVE POTENTIAL RISKS OF DEATH, PERSONAL INJURY, OR SEVERE PROPERTY OR ENVIRONMENTAL DAMAGE ("CRITICAL APPLICATIONS"). CIRRUS LOGIC PRODUCTS ARE NOT DESIGNED, AUTHORIZED OR WARRANTED FOR USE IN PRODUCTS SURGICALLY IMPLANTED INTO THE BODY, AUTOMOTIVE SAFETY OR SECURITY DEVICES, NUCLEAR SYSTEMS, LIFE SUPPORT PRODUCTS OR OTHER CRITICAL APPLICATIONS. INCLUSION OF CIRRUS LOGIC PRODUCTS IN SUCH APPLICATIONS IS UNDERSTOOD TO BE FULLY AT THE CUSTOMER'S RISK AND CIRRUS LOGIC DISCLAIMS AND MAKES NO WARRANTY, EXPRESS, STATUTORY OR IMPLIED, INCLUDING THE IMPLIED WARRANTIES OF MERCHANTABILITY AND FITNESS FOR PARTICULAR PURPOSE, WITH REGARD TO ANY CIRRUS LOGIC PRODUCT THAT IS USED IN SUCH A MANNER. IF THE CUSTOMER OR CUSTOMER'S CUSTOMER USES OR PERMITS THE USE OF CIRRUS LOGIC PRODUCTS IN CRITICAL APPLICATIONS, CUSTOMER AGREES, BY SUCH USE, TO FULLY INDEMNIFY CIRRUS LOGIC, ITS OFFICERS, DIRECTORS, EMPLOYEES, DISTRIBUTORS AND OTHER AGENTS FROM ANY AND ALL LIABILITY, INCLUDING ATTORNEYS' FEES AND COSTS, THAT MAY RESULT FROM OR ARISE IN CONNECTION WITH THESE USES.

This document is the property of Cirrus Logic and by furnishing this information, Cirrus Logic grants no license, express or implied, under any patents, mask work rights, copyrights, trademarks, trade secrets or other intellectual property rights. Any provision or publication of any third party's products or services does not constitute Cirrus Logic's approval, license, warranty or endorsement thereof. Cirrus Logic gives consent for copies to be made of the information contained herein only for use within your organization with respect to Cirrus Logic integrated circuits or other products of Cirrus Logic, and only if the reproduction is without alteration and is accompanied by all associated copyright, proprietary and other notices and conditions (including this notice). This consent does not extend to other copying such as copying for general distribution, advertising or promotional purposes, or for creating any work for resale. This document and its information is provided "AS IS" without warranty of any kind (express or implied). All statutory warranties and conditions are excluded to the fullest extent possible. No responsibility is assumed by Cirrus Logic for the use of information herein, including use of this information as the basis for manufacture or sale of any items, or for infringement of patents or other rights of third parties. Cirrus Logic, Cirrus, the Cirrus Logic logo design, and SoundClear are among the trademarks of Cirrus Logic. Other brand and product names may be trademarks or service marks of their respective owners.

**REVISION HISTORY**

<b>DATE</b>	<b>REV</b>	<b>ORIGINATOR</b>	<b>CHANGES</b>
26/09/11	4.4	JMacD	Order codes changed from WM8950GEFL/V and WM8950GEFL/RV to WM8950CGEFL/V and WM8950CGEFL/RV to reflect change to copper wire bonding.
26/09/11	4.4	JMacD	Package diagram changed to DM102.C
12/08/16	4.5	PH	MICBIAS voltage (MBVSEL=1) updated to $0.75 \times AVDD$ . System clock timing requirements updated.

# Mouser Electronics

Authorized Distributor

Click to View Pricing, Inventory, Delivery & Lifecycle Information:

[Cirrus Logic:](#)

[WM8950CGEFL/V](#) [WM8950CGEFL/RV](#) [WM8950GEFL/V](#)

## Данный компонент на территории Российской Федерации

### Вы можете приобрести в компании MosChip.

Для оперативного оформления запроса Вам необходимо перейти по данной ссылке:

<http://moschip.ru/get-element>

Вы можете разместить у нас заказ для любого Вашего проекта, будь то серийное производство или разработка единичного прибора.

В нашем ассортименте представлены ведущие мировые производители активных и пассивных электронных компонентов.

Нашей специализацией является поставка электронной компонентной базы двойного назначения, продукции таких производителей как XILINX, Intel (ex.ALTERA), Vicor, Microchip, Texas Instruments, Analog Devices, Mini-Circuits, Amphenol, Glenair.

Сотрудничество с глобальными дистрибьюторами электронных компонентов, предоставляет возможность заказывать и получать с международных складов практически любой перечень компонентов в оптимальные для Вас сроки.

На всех этапах разработки и производства наши партнеры могут получить квалифицированную поддержку опытных инженеров.

Система менеджмента качества компании отвечает требованиям в соответствии с ГОСТ Р ИСО 9001, ГОСТ РВ 0015-002 и ЭС РД 009

### Офис по работе с юридическими лицами:

105318, г.Москва, ул.Щербаковская д.3, офис 1107, 1118, ДЦ «Щербаковский»

Телефон: +7 495 668-12-70 (многоканальный)

Факс: +7 495 668-12-70 (доб.304)

E-mail: [info@moschip.ru](mailto:info@moschip.ru)

Skype отдела продаж:

moschip.ru

moschip.ru\_4

moschip.ru\_6

moschip.ru\_9