

# ABC600 Series

## AC-DC/DC-DC Open Frame Power Supplies

The ABC600 Series of open frame power supplies feature a wide universal AC input range of 90 – 277 VAC, offering 600 W of output power in a compact footprint.

The high efficiency and high power density of the ABC family ensures minimal power loss in end-use equipment, thereby facilitating higher reliability, easier thermal management and meets regulatory approvals for environmentally-friendly end products.

ABC Series power supplies are ideal for telecom, datacom, industrial equipment and other applications.



### Key Features & Benefits

- 600 W standard, 420 W convection cooled
- Size: 5.0" x 8.0" x 1.6" (127.0 x 203.2 x 40.6 mm)
- High efficiency up to 94.0%
- Universal input voltage range: 90-277 VAC
- Active power factor correction
- Less than 5 W dissipation at standby mode
- Parallel operation with active current sharing
- Digital control for circuit loop and power management
- Fully protected (OTP, OCP, OVP, SCP)
- Power Management Bus for control, programming and monitoring
- Both AC input and DC input are available
- Designed to meet Class B per CISPR 22 and EN 55022
- Approved to the latest edition of the following standards: UL/CSA60950-1, EN60950-1, and IEC60950-1
- CE marked LVD

### Applications

- Instrumentation
- Lighting
- Industrial Applications
- Applied Computing
- Datacom
- Renewable Energy
- Test and Measurement
- Robotics
- Wireless Communication
- Process Control



**bel** POWER  
SOLUTIONS &  
PROTECTION

a bel group

[belfuse.com/power-solutions](http://belfuse.com/power-solutions)

## 1. MODEL SELECTION

MODELS	OUTPUT VOLTAGE (VDC)	MAX LOAD CONVECTION	MAX LOAD 300 LFM	MINIMUM LOAD	RIPPLE & NOISE	TOTAL REGULATION
ABC600-1012G	12 V	35.0 A	50.0 A	0 A	1%	± 2%
ABC600-1015G	15 V	28.0 A	40.0 A	0 A	1%	± 2%
ABC600-1024G	24 V	17.5 A	25.0 A	0 A	1%	± 2%
ABC600-1028G	28 V	15.0 A	21.4 A	0 A	1%	± 2%
ABC600-1048G	48 V	8.8 A	12.5 A	0 A	1%	± 2%
V <sub>fan</sub> (all models)	12 V	1.0 A	1.0 A	0 A	1%	± 20%
V <sub>sb</sub> (all models)	5 V	1.0 A	1.0 A	0 A	2%	± 2%

### NOTES:

1. Peak current rating on V1 (main output) is 120% of max, lasting 3 seconds with max of 10% duty cycle.
2. Combined output power of V1 plus fan supply and standby supply should not exceed max power rating.
3. +/-20% tolerance of V<sub>fan</sub> includes the factors of set point accuracy, line and load regulation.
4. Air flow over long edge (either direction) required for air flow rating. See mechanical drawing, Figure 7 on page 11.
5. More than 800K hours MTBF is to be calculated according to Bellcore TR-332 standard current edition at 25 °C.

## 2. OVERVIEW

The ABC600 SERIES AC-DC/DC-DC power supply can operate using AC or DC input. It is a highly efficient front-end power supply. The PFC stage adopts an analog controller in continuous conduction mode to achieve high power factor and high efficiency. The DC/DC stage is fully DSP controlled and employs soft switching resonant techniques in conjunction with synchronous rectification for high efficiency and better thermal control. With a wide input operational voltage range and minimal linear derating of output power with temperature, the ABC600 SERIES maximizes power availability in demanding server, network, and other high availability applications. The supply is convection cooled or fan cooled and ideally suited for integration with a matching airflow path. An active OR-ing MOSFET on the output ensures no reverse current and renders the supply ideally suited for operation in redundant power systems. The always-on standby output V<sub>sb</sub> (5 Volts) provides power to external power distribution and management controllers. It is protected with an active OR-ing diode for maximum reliability. In addition, the Power Management Bus allows full monitoring of the supply, including input and output voltage, current, power, and internal temperatures. Current share signal (V1\_I<sub>share</sub>) is used for current sharing, and the difference between two units is within 2.5 A if system load is more than 25% of full load. The current share signal (V1\_I<sub>share</sub>) voltage shall be a linear function  $V_{cs} = 8 \times I_{out}/I_{max}$  for a single power supply. Example: for ABC600-1012G, VCS is 8 V at 50 A loading; I<sub>max</sub> is 50 A of ABC600-1012G.

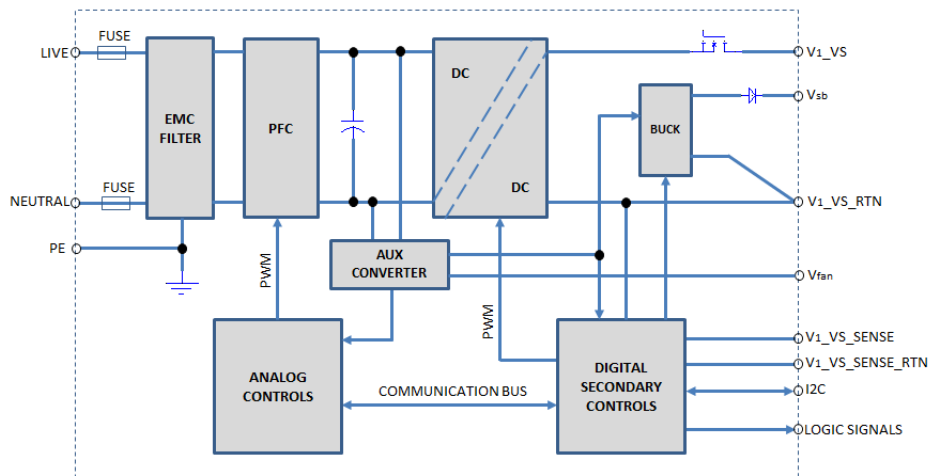

Figure 1. ABC600 SERIES Block Diagram

### 3. INPUT SPECIFICATIONS

General Condition:  $T_{amb} = -25$  to  $70^{\circ}\text{C}$  unless otherwise noted.

PARAMETER	DESCRIPTION / CONDITION	MIN	NOM	MAX	UNIT
$V_{in}$	Input Voltage Ranges	Universal Input		90	VAC
				120	VDC
$I_{in\ max}$	Max Input Current	$V_{in} = 90$ VAC/60 Hz, Full load			9 Arms
$I_{inrush}$	Inrush Current Limitation	$V_{i\ min}$ to $V_{i\ max}$ ,			20 Apk
$F_i$	Input Frequency	47	50/60	63	Hz
PF	Power Factor	$V_{in\ nom}$ , 50 Hz, > 50% full load.			0.95
$\eta$	Efficiency without Fan	$V_{in} = 230$ VAC, 20% of Full load, $T_{amb} = 25^{\circ}\text{C}$		0.99	91.0
		$V_{in} = 230$ VAC, 50% of Full load, $T_{amb} = 25^{\circ}\text{C}$			94.0
		$V_{in} = 230$ VAC, 100% of Full load, $T_{amb} = 25^{\circ}\text{C}$			93.0
$P_{min}$	Min Power at no Load	$V_{in} = 120$ VAC, $T_{amb} = 25^{\circ}\text{C}$ , if diable V1			5 W
$I_{Leakage}$	Leakage Current	$V_{in} = 120$ VAC, $T_{amb} = 25^{\circ}\text{C}$ , Input to Earth			3 mA
		$V_{in} = 277$ VAC, $T_{amb} = 25^{\circ}\text{C}$ , Input to Earth			3 mA
$T_{hold}$	Hold-up Time	$V_{in} = 230$ VAC, Full load, $V_{sb}$ within regulation, stay within $90\% \cdot V_{1\ nom}$ from AC zero point			16 ms

### 4. OUTPUT SPECIFICATIONS

General Condition:  $T_{amb} = -25$  to  $70^{\circ}\text{C}$  unless otherwise noted.

PARAMETER	DESCRIPTION / CONDITION	MIN	NOM	MAX	UNIT	
<b>Main Output V1</b>						
$V_{1\ set}$	Output Set Point Accuracy	$0.5 \cdot I_{1\ nom}$ , $T_{amb} = 25^{\circ}\text{C}$		-0.5	+0.5 % $V_{1\ nom}$	
$V_{1\ nom}$	Nominal Output Voltage	Refer to ordering information table as above				VDC
$V_{1\ total\ reg}$	Total Regulation	$V_{in\ min}$ to $V_{in\ max}$ , 0 to 100% $I_{1\ nom}$ , $T_{amb\ min}$ to $T_{amb\ max}$		-2	+2 % $V_{1\ nom}$	
$V_{adj}$	Voltage Adjustment	V1 output voltage could be adjusted with the potentiometer or I <sup>2</sup> C protocol		+/-10 % $V_{1\ nom}$		
$V_{1\ pp}$	Output Ripple Voltage	$V_{1\ nom}$ , $I_{1\ nom}$ , 20 MHz BW #1			1	% $V_{1\ nom}$
$V_{1\ Load\ reg}$	Load Regulation	$V_i = V_{1\ nom}$ , 0... 100% $I_{1\ nom}$			2	% $V_{1\ nom}$
$V_{1\ Line\ reg}$	Line Regulation	$V_i = V_{i\ min} \dots V_{i\ max}$			1	% $V_{1\ nom}$
$I_{share}$	Current Sharing abs (I1-I2), between any two units in parallel)	when Bus load $\geq 25\%$ of full load			2.5	A
		when Bus load $< 25\%$ of full load #2			3.5	A
$V_{1\ dyn}$	Dynamic Load Regulation	50 to 100% of load change, 50 Hz, 50% duty cycle, 1 A/us			-5	+5 % $V_{1\ nom}$
$T_{v1\ rec}$	Recovery Time				0.5	5 mS
$V_{1\ Overshoot}$	V1 overshoot at turn-on				1	%
$C_{v1\ Load}$	Capacitive Loading	$T_{amb} = 25^{\circ}\text{C}$ , $C_{Load} = 220\ \mu\text{F}/\text{A} \cdot I_{1\ nom}$				$\mu\text{F}$
<b>Standby Output <math>V_{sb}</math></b>						
$V_{sb\ nom}$	Nominal Output Voltage				5	VDC
$V_{sb\ total\ reg}$	Total Regulation	$V_{sb\ min}$ to $V_{sb\ max}$ , 0 to 100% $I_{sb\ nom}$ , $T_{amb\ min}$ to $T_{amb\ max}$		-2	+2 % $V_{sb}$	
$P_{sb\ nom}$	Nominal Output Power	$V_{sb} = 5$ VDC			5	W
$V_{sb\ pp}$	Output Ripple Voltage	$V_{sb\ nom}$ , $I_{sb\ nom}$ , 20 MHz BW			100	mV



Asia-Pacific  
+86 755 298 85888

Europe, Middle East  
+353 61 225 977

North America  
+1 408 785 5200

$V_{sb}$ Load reg	Load Regulation	$V_{sb} = V_{sb\ nom}, 0...100\% I_{sb\ nom}$	4.8	5.1	V
$V_{sb}$ Line reg	Line Regulation	$V_{sb} = V_{sb\ min}...V_{sb\ max}$		2	% $V_{sb}$
$I_{sb\ max}$	Current Limitation	Constant current limit then hiccup	120	150	% $I_{sb}$
$V_{sb\ dyn}$	Dynamic Load Regulation	50 to 100% of load change, 50 Hz, 50% duty cycle, 1A/us	-5	+5	% $V_{sb}$
$T_{sb\ rec}$	Recovery Time		0.5	5	mS
$C_{sb\ Load}$	Capacitive Loading	$T_{amb} = 25^{\circ}C$		220	$\mu F$
<b>Fan Output <math>V_{fan}</math></b>					
$V_{fan\ nom}$	Nominal Output Voltage		12		VDC
$V_{fan\ total\ reg}$	Total Regulation	$V_{fan\ min}$ to $V_{fan\ max}$ , 0 to 100% $I_{fan\ nom}$ , $T_{amb\ min}$ to $T_{amb}$	-20	+20	% $V_{fan\ nom}$
$P_{fan\ nom}$	Nominal Output Power	$V_{fan} = 12\ VDC$ , Power derating linearly to 50% at 70°C, refer to figure 2	12		W
$V_{fan\ pp}$	Output Ripple Voltage	$V_{fan\ nom}$ , $I_{fan\ nom}$ , 20 MHz BW		2	% $V_{fan\ nom}$
$I_{fan\ max}$	Current Limitation	$T_{amb} = 25^{\circ}C$	270		% $I_{fan\ nom}$
$V_{fan\ dyn}$	Dynamic Load Regulation	50 to 100% of load change, 50 Hz, 50% duty cycle, 1A/us	-5	+5	% $V_{fan\ nom}$
$T_{fan\ rec}$	Recovery Time		0.5	5	mS
$C_{fan\ Load}$	Capacitive Loading	$T_{amb} = 25^{\circ}C$		220	$\mu F$

**NOTES:**

1. The output noise and ripple measurement was made with 20 MHz bandwidth using a 6 inch twisted pair, terminated with a 10 uF tantalum capacitor in parallel with a 0.1 uF ceramic capacitor.
2. For ABC600-1048G/52G, the current share abs (I1-I2) should be less than 3 A at light load (< 25% of full load).

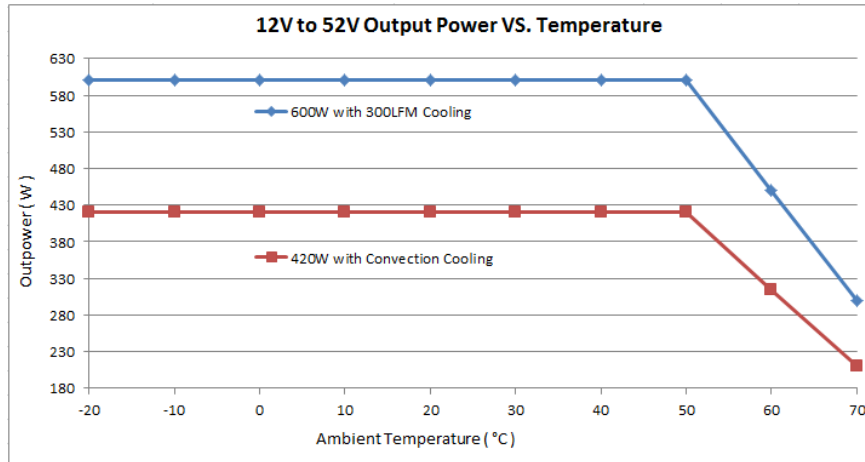

Figure 2. Output Power vs. Temperature

**NOTE:** Power derating linearly to 50% at 70°C for the output including main output V1,  $V_{fan}$ .

## 5. PROTECTION SPECIFICATIONS

PARAMETER	DESCRIPTION / CONDITION	MIN	NOM	MAX	UNIT
F	Input Fuses (L+N)	Not user accessible, slow-acting (F)			A
$V_{in\,ov}$	Input Over Voltage Limit	285VAC/395VDC	/	295VAC/405VDC	V
	Recovery	280VAC/390VDC	/	290VAC/400VDC	V
$V_{in\,uv}$	Input Under Voltage Limit	75VAC/105VDC	/	85VAC/115VDC	V
	Recovery	80VAC/110VDC	/	90VAC/120VDC	V
$V_{1\,ov}$	OV Threshold $V_1$	110		132	% $V_{1\,norm}$
$V_{sb\,ov}$	OV Threshold $V_{sb}$	110		120	% $V_{sb\,norm}$
$I_{1\,lim}$	Current Limit $V_1$	Over current limit meets below curve, Figure 3			
$I_{sb\,lim}$	Current Limit $V_{sb}$	1.2		2	A
$I_{fan\,lim}$	Current Limit $V_{fan}$	$T_{amb} = 25^{\circ}C$			A
$T_{SD}$	Over Temperature on Heat Sinks	No damage, Automatic shut-down and recovers.			

The Output is protected against an overload or a Short Circuit for indefinite duration. The unit shall meet this requirement when in general operating conditions. Over current limit should meet below curve within +/-1.5 A tolerance, and the unit is allowed to hiccup under over current conditions.

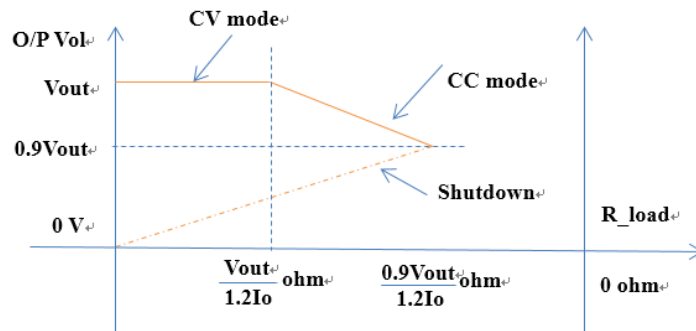

Figure 3. Over Current Mode

## 6. GRAPHICAL USER INTERFACE

Bel Power Solutions provides with its “Bel Power Solutions I2C Utility” a Windows® XP/Vista/Win7 compatible graphical user interface allowing the programming and monitoring of the ABC600 Series Front-End. The utility can be downloaded on [www.belpowersolutions.com](http://www.belpowersolutions.com) and supports both the PSMI and Power Management Bus protocols.

The GUI allows automatic discovery of the units connected to the communication bus and will show them in the navigation tree. In the monitoring view the power supply can be controlled and monitored.

Reference Documents:

- BCA.00029\_AA\_ABC600 Series Power Management Bus Communication Manual.pdf
- Power Management Bus Specification Part I Revision 1.1
- Power Management Bus Specification Part II Revision 1.1
- System Management Bus (SMBus) Specification Revision 2.0



Asia-Pacific  
+86 755 298 85888

Europe, Middle East  
+353 61 225 977

North America  
+1 408 785 5200

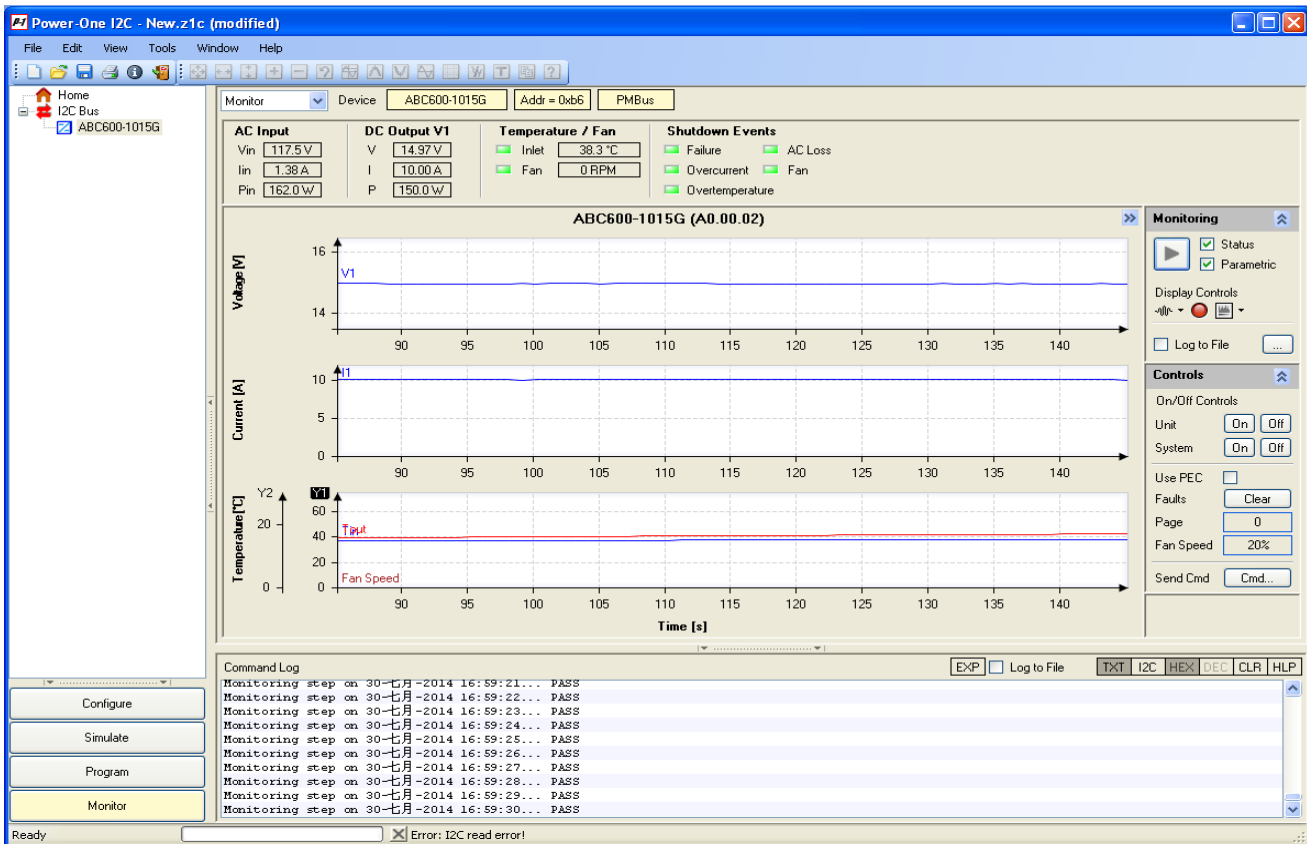

Figure 4. I2C Bus to DSP

The sensor commands shall meet the following accuracy requirements:

COMMAND	10%-20% OF MAX LOAD	20%-100% OF MAX LOAD	Remark
READ_IIN	< 0.5 A	+/-20%	It is for corresponding to max input current
READ_IOUT	+/-5%	+/-2.5 A	It is for corresponding to max output current
READ_VIN	+/-3%	+/-2.5 V	It is for corresponding to max input voltage
READ_VOUT	+/-2%	+/-2%	
READ_PIN	- - -	+/-20%	It is for corresponding to max input power
READ_POUT	+/-5 %	+/-5%	It is for corresponding to max output power

## 7. TIMING DIAGRAM AND SIGNALS

Unless defined otherwise, all control signals shall be TTL compatible with respect to the output return and shall be isolated from the primary circuit and be SELV rated. All input signals shall be driven from an open collector with the pull-up resistor located in the power supply and shall be capable of sourcing up to 4 mA. Unless otherwise specified, signal levels for parameters listed in the table below are general LVTTTL signals.

PARAMETER	DESCRIPTION / CONDITION
A0, A1	Power Management Bus selected address Pin.
SDA, SCL	SDA is serial data signal and SCL is serial clock signal (I <sup>2</sup> C).
SMB_ALERT_L	Output alert signal. It shall be an open collector with the pull-up resistor located at the receiving end. This signal will be asserted due to fault or warning events. High = Normal, Low = Alert, Refer to Figure 5.
V <sub>1</sub> _Ishare	Current share signal. The PSU can operate at redundant mode by connecting V <sub>1</sub> _Ishare signal of each power supply together.
V <sub>1</sub> _VS_SENSE, V <sub>1</sub> _VS_SENSE_RTN	Remote Sense signal for V <sub>1</sub> , V <sub>1</sub> _VS_SENSE is positive sense, V <sub>1</sub> _VS_SENSE_RTN is negative sense.
V <sub>sb</sub> , SGND	V <sub>sb</sub> is standby output, and SGND is secondary ground.
+VP	Source voltage located at receiving end. Provide a voltage for power good signal. Refer to Figure 6.
PW_OK_H	Output power good signal. It is isolated from the output. Goes high/low when output is within regulation. Refer to Figure 6 (two methods for Power Good connection).
INHIBIT_L, INHIBIT_L_RTN	Power up signal. It is isolated from the output. Apply a DC voltage between INHIBIT_L and INHIBIT_L_RTN can power up the unit. Refer to Figure 6.
V <sub>fan</sub> , SGND	V <sub>fan</sub> is fan output to provide energy for user, and SGND is secondary ground.

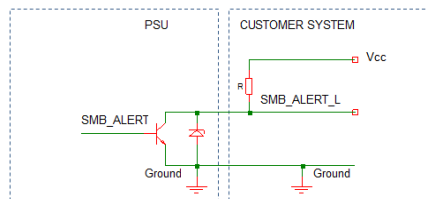
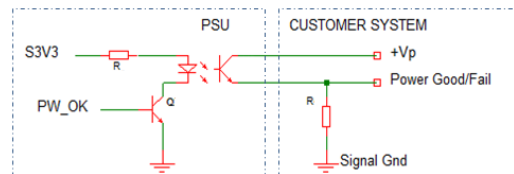
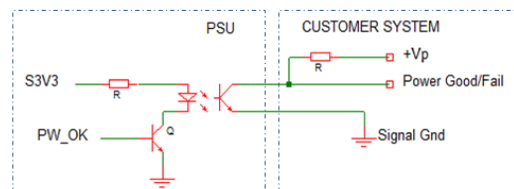

Figure 5. SMB\_ALERT\_L Connections



Option 1: when PowerGood/Fail=H, Power is good



Option 2: when PowerGood/Fail=L, Power is good

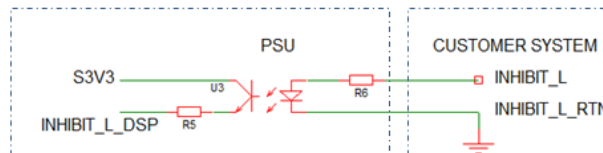
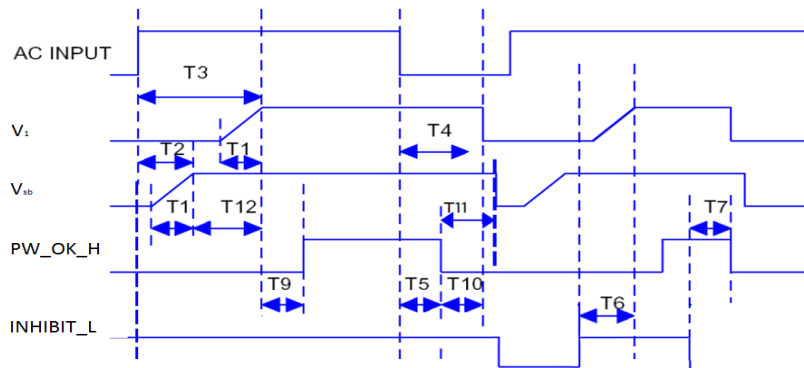

Figure 6. Isolated Signal Output Connections

PARAMETER	SYMBOL	MIN	MAX	UNIT
Output High Voltage	$V_{oh}$	2.4	3.6	V
Output Low Voltage	$V_{ol}$	0	0.4	V
Input High Voltage	$V_{ih}$	2.0	3.6	V
Input Low Voltage	$V_{il}$	0	0.8	V
Sink current(PW_OK_H)	$I_{sink}$		4	mA
Operate voltage (between INHIBIT_L and INHIBIT_L_RTN)	$V_{ope}$	2.0	10	V
Max operate current (SMB_ALERT_L)	$I_{ope}$		30	mA

Table 1. Low-Voltage TTL (LVTTTL) Voltage Levels



PARAMETER	CONDITION / COMMENTS	MIN	NOM	MAX	UNIT
T1 ( $T_{V_{out\_rise}}$ )	Output voltage rise time from each output	0.5		100	mS
T2 ( $T_{VAC_{on\_Vsb_{on}}}$ )	Delay from AC being applied to $V_{sb}$ being within regulation			2500	mS
T3 ( $T_{VAC_{on\_V1_{on}}}$ )	Delay from AC being applied to $V_1$ being within regulation			3000	mS
T4 ( $T_{V1\_holdup}$ )	Time $V_1$ stay within 90% normal output after loss of AC	16			mS
T5 ( $T_{pwok\_holdup}$ )	Delay from loss of AC to de-assertion of PW_OK_H	10			mS
T6 ( $T_{inhibitL\_V1_{on}}$ )	Delay INHIBIT_L active to $V_1$ output voltages within regulation			1000	mS
T7 ( $T_{inhibitL\_pwok}$ )	Delay from INHIBIT_L de-active to PW_OK_H being de-asserted			50	mS
T9 ( $T_{V1_{on\_pwok}}$ )	Delay from $V_1$ within regulation to PW_OK_H asserted at turn on	100		1000	mS
T10 ( $T_{pwok_{off\_V1}}$ )	Delay from PW_OK_H de-asserted to $V_1$ dropping out of regulation at 60% loading of full load	1			mS
T11 ( $T_{pwok_{off\_Vsb}}$ )	Delay from PW_OK_H de-asserted to $V_{sb}$ dropping out of regulation	20			mS
T12 ( $T_{Vsb\_V1}$ )	Delay from $V_{sb}$ being in regulation to $V_1$ being in regulation at AC turn on	50		1000	mS



## 8. ENVIROMENTAL SPECIFICATIONS

PARAMETER	DESCRIPTION / CONDITION	SPECIFICATION
Operating Temperature	See derating charts above Figure 2, $T_{amb\ min} = -25^{\circ}C$ , $T_{amb\ max} = 70^{\circ}C$	-25 to 70°C
Storage Temperature		-40 to 85°C
Relative Humidity	Operating humidity: Non-operating humidity, non-condensing	5%-90% 5%-95%
Altitude	Operating: Non-operating:	10,000 ft. 40,000 ft.
CE Mark	Complies with LVD Directive	
Conducted Emissions:	EN55022-B, CISPR22-B, FCC PART15-B	Criterion B
Static Discharge	EN61000-4-2, Level-3	Criterion A
RF Field Susceptibility	EN61000-4-3, Level-3	Criterion A
Fast Transients/Bursts	EN61000-4-4, Level-3	Criterion B
Radiated Emissions	EN55022-B, CISPR22-B, FCC PART15-B	Criterion B
Surge Susceptibility	EN61000-4-5, Level-3	Criterion B
RF Immunity	EN61000-4-6, Level-3	Criterion A
Magnetic Fields	EN61000-4-8, Level-4	Criterion A
Voltage Interruptions	EN61000-4-11	Criterion B
Harmonic Current	EN61000-3-2, Level A	Criterion A
Voltage Fluctuations / Flicker	EN61000-3-3	
Vibration	Operating: Random vibration; 5 to 500 Hz (10 minutes, each axis). Non-Operating: Random vibration; 5 to 500 Hz (10 minutes, each axis).	Max. 2.4Grms Max. 6Grms
Shock	Operating: half-sine, $11 \pm 3$ mS 3-axis. Non-Operating: half-sine, $11 \pm 3$ mS 3-axis.	Max. 15G Max. 40G

## 9. SAFETY / AGENCY SPECIFICATIONS

Maximum electric strength testing is performed according to UL/CSA60950-1, EN60950-1, and IEC60950-1. Input-to-output electric strength tests should not be repeated in the field. Bel Power Solutions will not honor any warranty claims resulting from electric strength field tests.

PARAMETER	DESCRIPTION / CONDITION	SPECIFICATION
Agency Approvals	Approved to the latest edition of the following standards: CSA/UL60950-1, EN60950-1 and IEC60950-1. Nemko, cCSAus, CE	Approved by independent body (see CE Declaration)
Isolation Strength	Input (L/N) to case (PE) Input (L/N) to output Output to case (PE)	Basic Reinforced Functional
Creepage / Clearance	Primary (L/N) to protective earth (PE) Primary to secondary	Min 4.0/2.5 mm Min 8/5 mm
Electrical Strength Test	Input to case Input to output Output and Signals to case	1840/2600 VAC/VDC 3000/4242 VAC/VDC 500 VDC



Asia-Pacific  
+86 755 298 85888

Europe, Middle East  
+353 61 225 977

North America  
+1 408 785 5200

## 10. CONNECTOR & PIN DESCRIPTIONS

CONNECTOR	PIN DESCRIPTION	HOUSING	CRIMP TERMINAL	WIRE GAUGE
J101	J101-1 = Live J101-2 = Live J101-3 = not fitted J101-4 = Neutral J101-5 = Neutral	Molex 09-50-3051 or equivalent	Molex 08-50-0105 or equivalent	AWG#18-16
J102	J102-1: A0 J102-2: A1 J102-3: SDA J102-4: SCL J102-5: SMB_ALERT_L J102-6: V1_ishare J102-7: V1_VS_SENSE J102-8: V1_VS_SENSE_RTN J102-9: SGND J102-10: Vsb J102-11: +VP J102-12: PW_OK_H J102-13: INHIBIT_L J102-14: INHIBIT_L_RTN J102-15: Vfan J102-16: SGND	JST PHDR-16VS or equivalent	JST SPHD-001T-P0.5 or equivalent	AWG#22-26
J103	J103: EARTH	NA	Molex 19002-0024 or equivalent	AWG#16
Output terminal J106/J107	J107 = V1_VS_RTN J106 = V1_VS	NA	Molex 0190670067 or equivalent	AWG#6

## 11. MECHANICAL SPECIFICATIONS

PARAMETER	CONDITIONS / DESCRIPTION
Dimensions (L x W x H)	203.2 x 127 x 40.64 mm
Mounting	(Location/Hardware); Dimensions Drawing Figure 7
Input	Connector type: Molex 26-62-4056 or equivalent; (J101); Figure 7
Output	Connector type: M4 screw terminal; (J106/107); Figure 7
Signal	Connector type: AMTEK 2211MS-208GW-U; (J102); Figure 7
Outline Drawing Pins/Functions	See Mechanical Drawing/ Figure 7
Weight	0.9 kg
Mounting distance	Distance from top of the components (component side) to the customer's metal chassis – Natural cooling: 101.6 mm Distance from top of the components (component side) to the customer's metal chassis – Force cooling: 5 mm <sup>1</sup>

<sup>1</sup> 5 mm is not required if there is insulator between PSU and customer chassis.

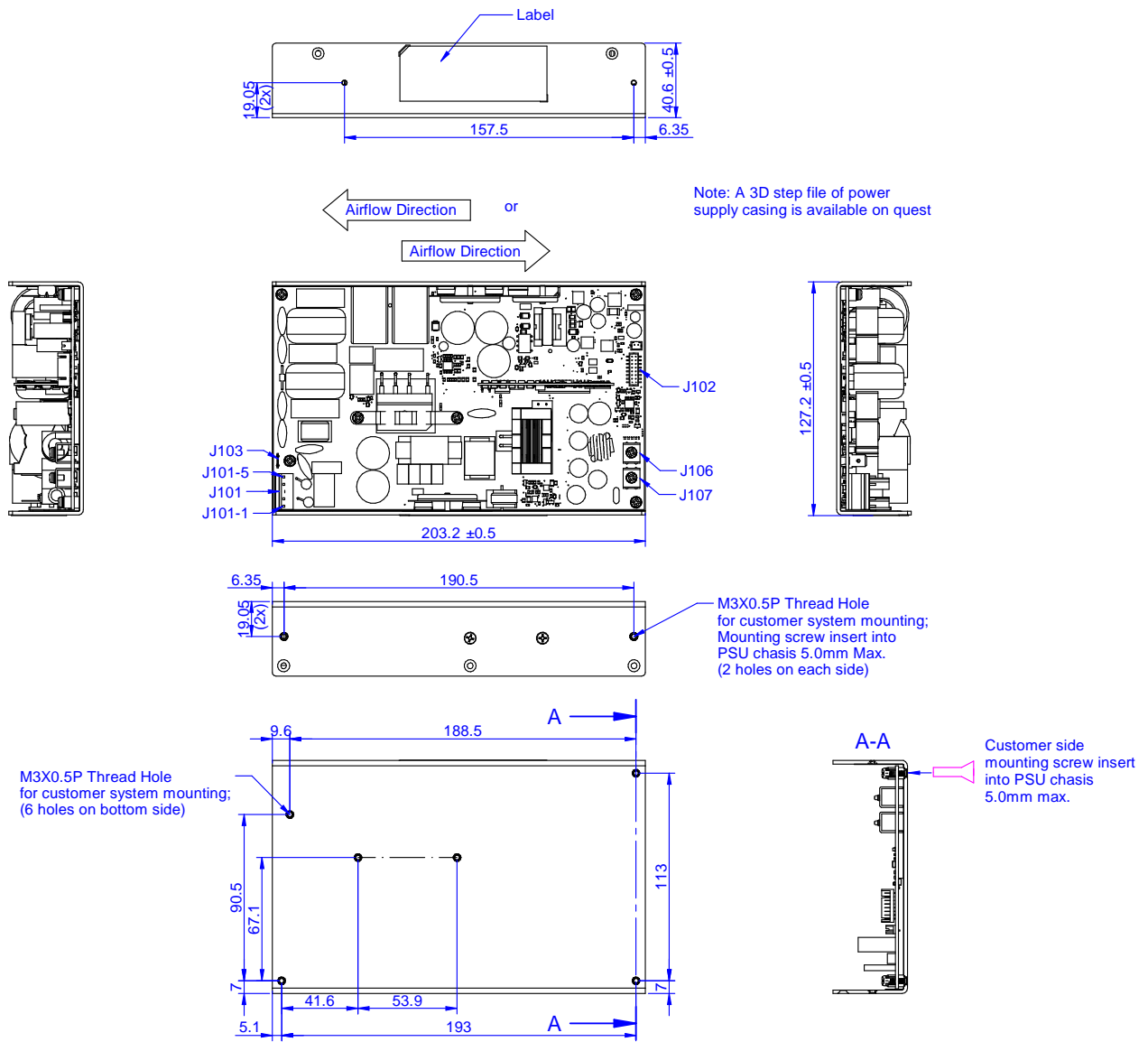



Figure 7. Mechanical Drawings

## 12. ACCESSORIES

ITEM	DESCRIPTION	ORDERING PART NUMBER	SOURCE
	<b>I²C Utility</b> Windows XP/Vista/7 compatible GUI to program, control and monitor PET Front-Ends (and other I²C units)	N/A	<a href="http://belfuse.com/power-solutions">belfuse.com/power-solutions</a>

## 13. REVISION HISTORY

DATE	REVISION	DESCRIPTION OF CHANGE	ECO/MCO REFERENCE NO.
2019-Jul-03	AI	Page 2: PN: ABC600-1052G removed from the Model selection table due to the Change lifecycle to RMA	C94367

**For more information on these products consult: [tech.support@psbel.com](mailto:tech.support@psbel.com)**

**NUCLEAR AND MEDICAL APPLICATIONS** - Products are not designed or intended for use as critical components in life support systems, equipment used in hazardous environments, or nuclear control systems.

**TECHNICAL REVISIONS** - The appearance of products, including safety agency certifications pictured on labels, may change depending on the date manufactured. Specifications are subject to change without notice.



[tech.support@psbel.com](mailto:tech.support@psbel.com)  
[belfuse.com/power-solutions](http://belfuse.com/power-solutions)

## Данный компонент на территории Российской Федерации

### Вы можете приобрести в компании MosChip.

Для оперативного оформления запроса Вам необходимо перейти по данной ссылке:

<http://moschip.ru/get-element>

Вы можете разместить у нас заказ для любого Вашего проекта, будь то серийное производство или разработка единичного прибора.

В нашем ассортименте представлены ведущие мировые производители активных и пассивных электронных компонентов.

Нашей специализацией является поставка электронной компонентной базы двойного назначения, продукции таких производителей как XILINX, Intel (ex.ALTERA), Vicor, Microchip, Texas Instruments, Analog Devices, Mini-Circuits, Amphenol, Glenair.

Сотрудничество с глобальными дистрибьюторами электронных компонентов, предоставляет возможность заказывать и получать с международных складов практически любой перечень компонентов в оптимальные для Вас сроки.

На всех этапах разработки и производства наши партнеры могут получить квалифицированную поддержку опытных инженеров.

Система менеджмента качества компании отвечает требованиям в соответствии с ГОСТ Р ИСО 9001, ГОСТ РВ 0015-002 и ЭС РД 009

### Офис по работе с юридическими лицами:

105318, г.Москва, ул.Щербаковская д.3, офис 1107, 1118, ДЦ «Щербаковский»

Телефон: +7 495 668-12-70 (многоканальный)

Факс: +7 495 668-12-70 (доб.304)

E-mail: [info@moschip.ru](mailto:info@moschip.ru)

Skype отдела продаж:

moschip.ru

moschip.ru\_4

moschip.ru\_6

moschip.ru\_9