

# PLW5630CB Series 5630

## Mid Power LED

### Product Datasheet



#### Description

Plessey PLW5630CB SMT LEDs are designed for optical indicators, indoor displays, automotive lighting, backlights for switches/symbols/LCD, tubular lighting and other general lighting applications and the light is emitted close to a Lambertian distribution. The LEDs are packed in reels containing 3000 pieces; each individual reel will be shipped in single intensity and colour bin, to provide close uniformity.

#### Features

- 5630 footprint (5.7x3.0x0.8mm)
- High reliability PLCC-2 packaging
- Diffused pale yellow resin
- 120 degree wide viewing angle

#### Applications

- Tubular Lighting
- Instrument panel backlighting
- Illumination symbols
- Automotive lighting
- General lighting

Variant	Colour	CCT (K)	
		Min.	Max.
PLW5630CB-2700	Warm White 2700K	2600	2800
PLW5630CB-3000	Warm White 3000K	2800	3100
PLW5630CB-3400	Warm White 3400K	3250	3650
PLW5630CB-4000	Neutral White 4000K	3800	4250
PLW5630CB-5000	Cool White 5000K	4750	5300
PLW5630CB-6500	Cool White 6500K	6000	7000

## **Absolute Maximum Ratings**

$T_A = +25^\circ\text{C}$  unless otherwise stated

Parameter	Symbol	Min.	Max.	Unit
DC Forward Current	$I_F$	-	180	mA
Peak Pulse Forward Current <sup>[1]</sup>	$I_{FP}$	-	200	mA
Power Dissipation	$P_D$	-	612	mW
Storage Temperature	$T_{stg}$	-40	+100	$^\circ\text{C}$
Junction Temperature	$T_J$	-	+115	$^\circ\text{C}$

<sup>[1]</sup> Pulse width 0.1ms, duty cycle  $\leq 10\%$

## **Electro-optical Characteristics**

$T_A = +25^\circ\text{C}$  unless otherwise stated

Parameter	Symbol	Condition	Min.	Typ.	Max.	Unit
Forward Voltage	$V_F$	$I_F = 150 \text{ mA}$	2.8	-	3.4	V
Reverse Current	$I_R$	$V_R = 5 \text{ V}$	-	-	10	$\mu\text{A}$
Colour Rendering Index <sup>[1]</sup>	$CRI$	$I_F = 150 \text{ mA}$	90	-	-	%
Thermal Resistance	$R_\theta$		-	30	-	K/W
Half-Intensity Angle	$2\theta_{1/2}$	$I_F = 150 \text{ mA}$	-	120	-	deg

<sup>[1]</sup> Tolerance  $\pm 2\%$

## **Recommended Operating Conditions**

In typical applications, for optimum LED performance

Parameter	Symbol	Min.	Max.	Unit
Operating Ambient Temperature	$V_F$	2.8	3.4	$^\circ\text{C}$

## Ordering Information

Name	Order Code	LF Min.	VF Max.
PLW5630CB-2700	PLW5630CBW27000	3A	V1 – V6
PLW5630CB-3000	PLW5630CBW30000		
PLW5630CB-3400	PLW5630CBW34000		
PLW5630CB-4000	PLW5630CBN40000	4A	
PLW5630CB-5000	PLW5630CBC50000		
PLW5630CB-6500	PLW5630CBC65000		

## Intensity Bin Groups

$I_F = 150\text{mA}$ ,  $T_A = +25^\circ\text{C}$ , unless otherwise stated

Group	Luminous Flux (lm)	
	Min.	Max.
3A	42	50
4A	50	55
5A	55	60

<sup>[1]</sup> Tolerance  $\pm 10\%$

## Forward Voltage Bin Groups

$I_F = 150\text{mA}$ ,  $T_A = +25^\circ\text{C}$ , unless otherwise stated

Group	Forward Voltage $V_F$ <sup>[1]</sup> (V)	
	Min.	Max.
V1	2.8	2.9
V2	2.9	3.0
V3	3.0	3.1
V4	3.1	3.2
V5	3.2	3.3
V6	3.3	3.4

<sup>[1]</sup> Tolerance  $\pm 0.1\text{V}$ .

## Chromaticity Binning

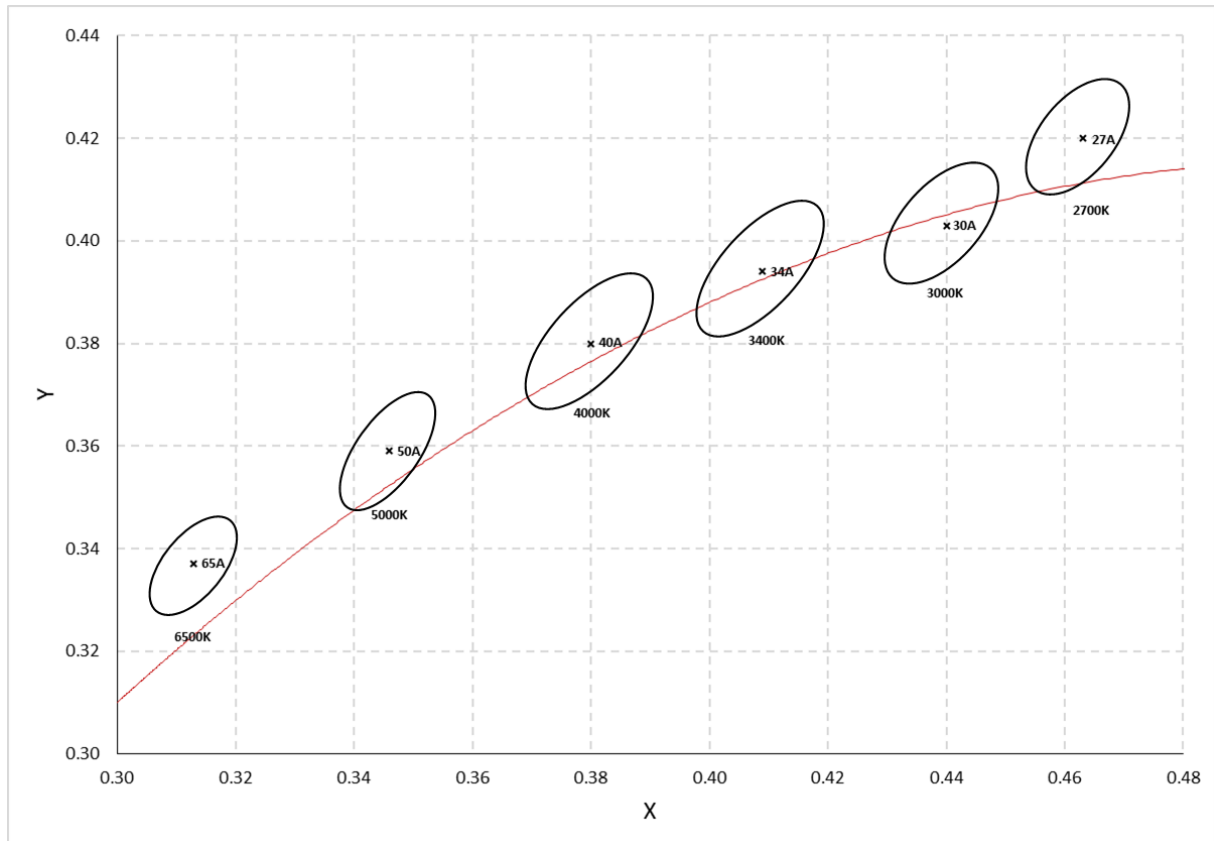

Figure 1: Colour Chromaticity Binning  
 Chromaticity tolerance:  $\pm 0.003$

CCT (K)	Bin	CIE x	CIE y	a	d	$\theta$
6500	65A	0.313	0.337	0.01115	0.00475	58°23'
5000	50A	0.346	0.359	0.0137	0.00590	59°37'
4000	40A	0.380	0.380	0.01565	0.00670	54°00'
3400	34A	0.409	0.394	0.01585	0.00695	52°28'
3000	30A	0.440	0.403	0.01390	0.00680	53°10'
2700	27A	0.463	0.420	0.01290	0.00685	53°17'

## Relative Spectral Emission

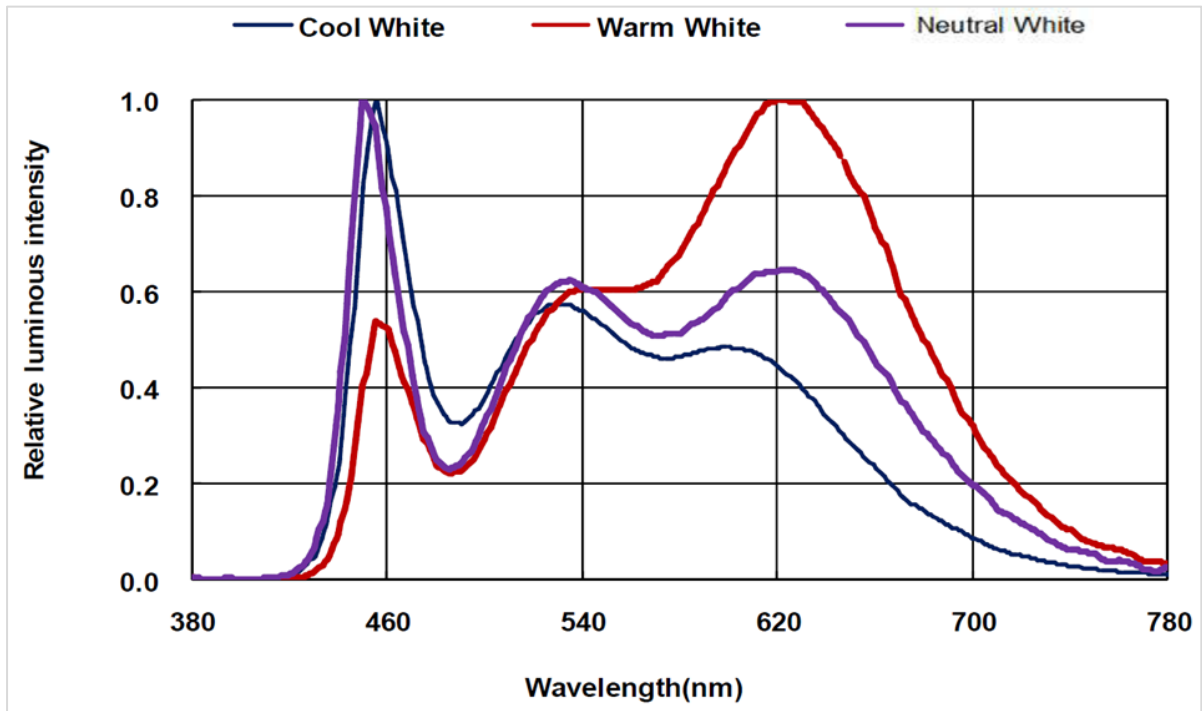

Figure 2: Normalised spectral power distribution

## Forward Current Characteristics

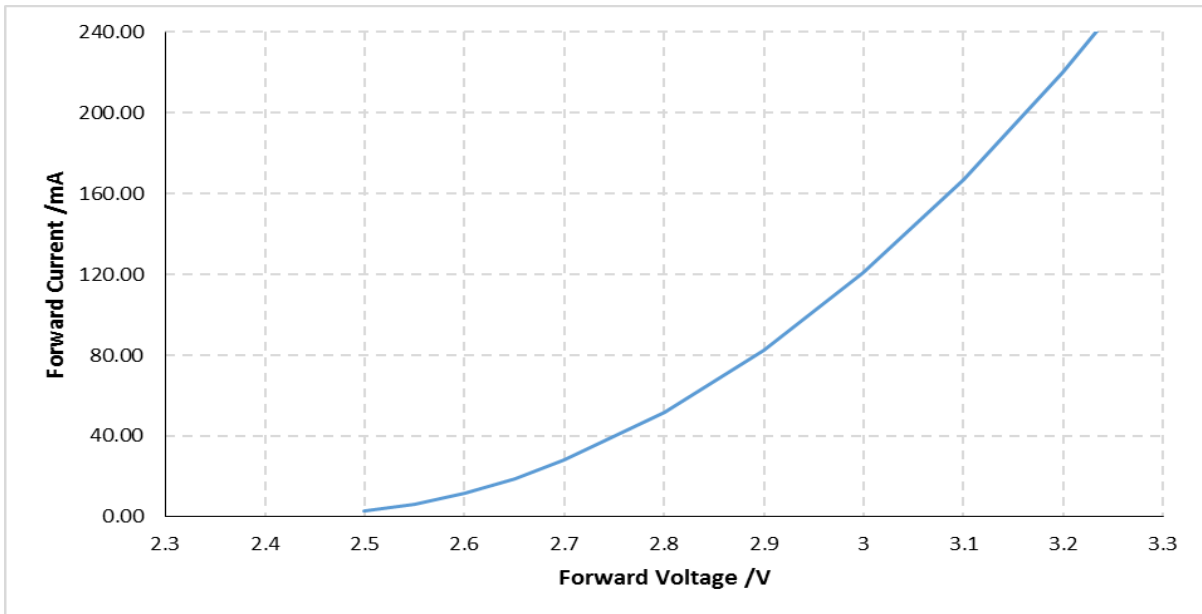

Figure 3: Typical forward current versus forward voltage ( $T_a=+25^{\circ}\text{C}$ )

### Forward Current Characteristics (Continued)

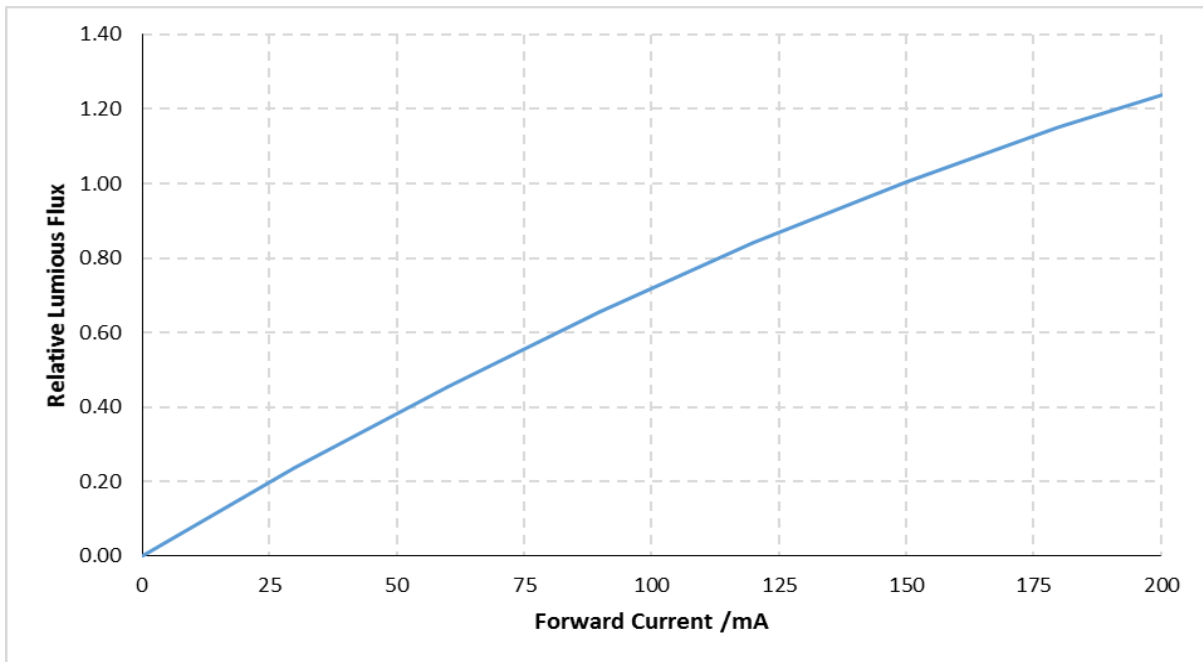

Figure 4: Relative luminous flux versus forward current ( $T_a=+25^{\circ}\text{C}$ ) Temperature Characteristics

### Temperature Characteristics

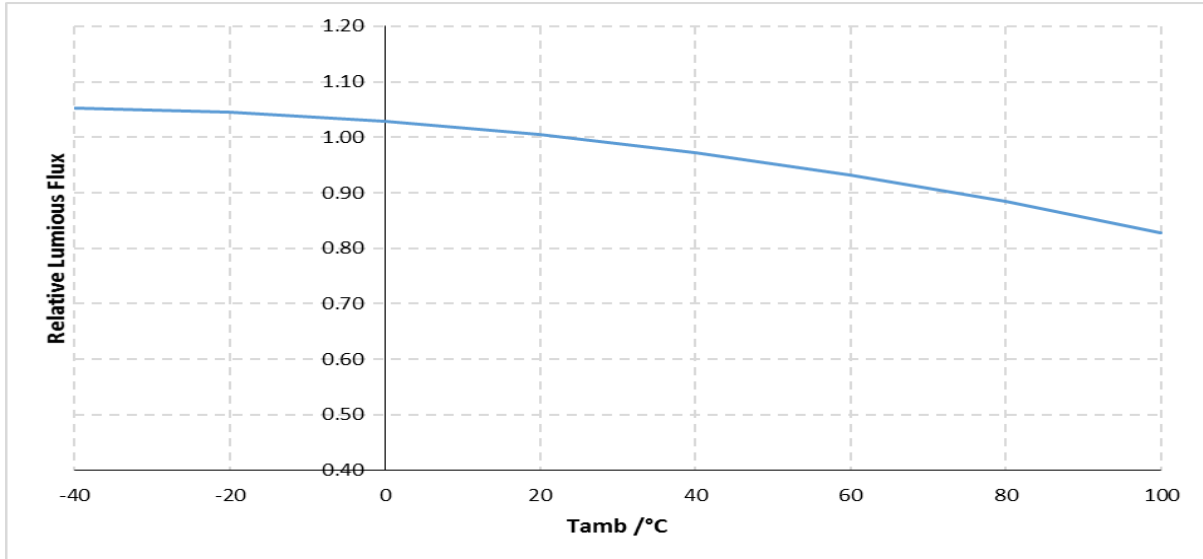
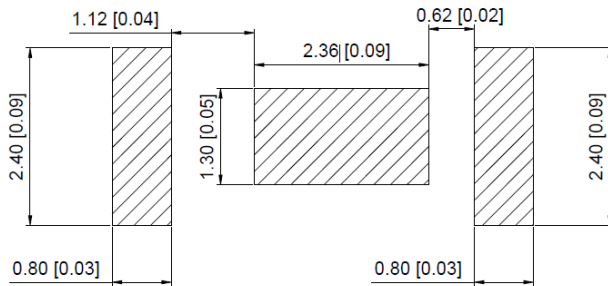

Figure 5: Relative Luminous Intensity versus ambient temperature ( $I_F=150\text{mA}$ )

## Package Outline Dimensions & Soldering Pattern

### Solder Pad Pattern Drawing



### Mechanical Package Drawing

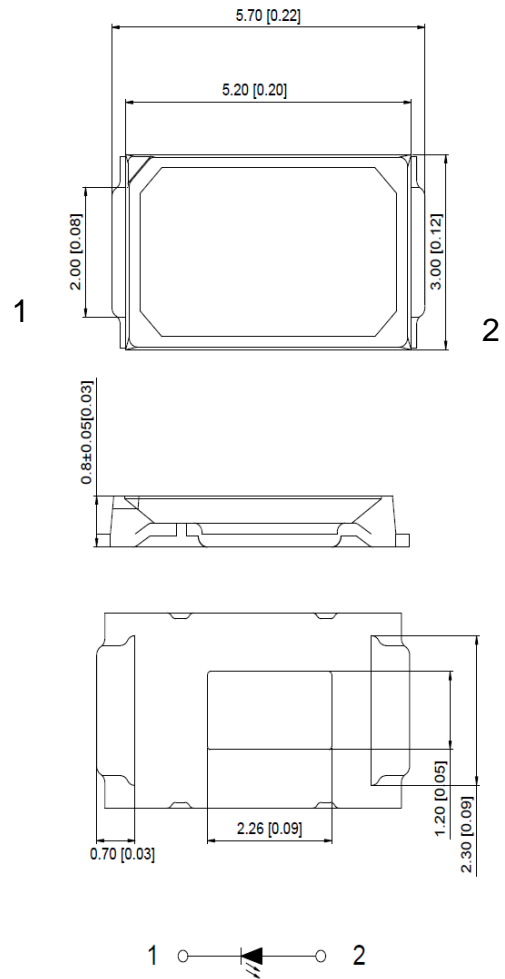

1. All dimensions units are millimeters.
2. All dimensions tolerances are  $\pm 0.15$ mm unless otherwise stated.

Figure 6: Mechanical Drawing & Soldering Pattern of the 5630 package

## Reflow Soldering Profile

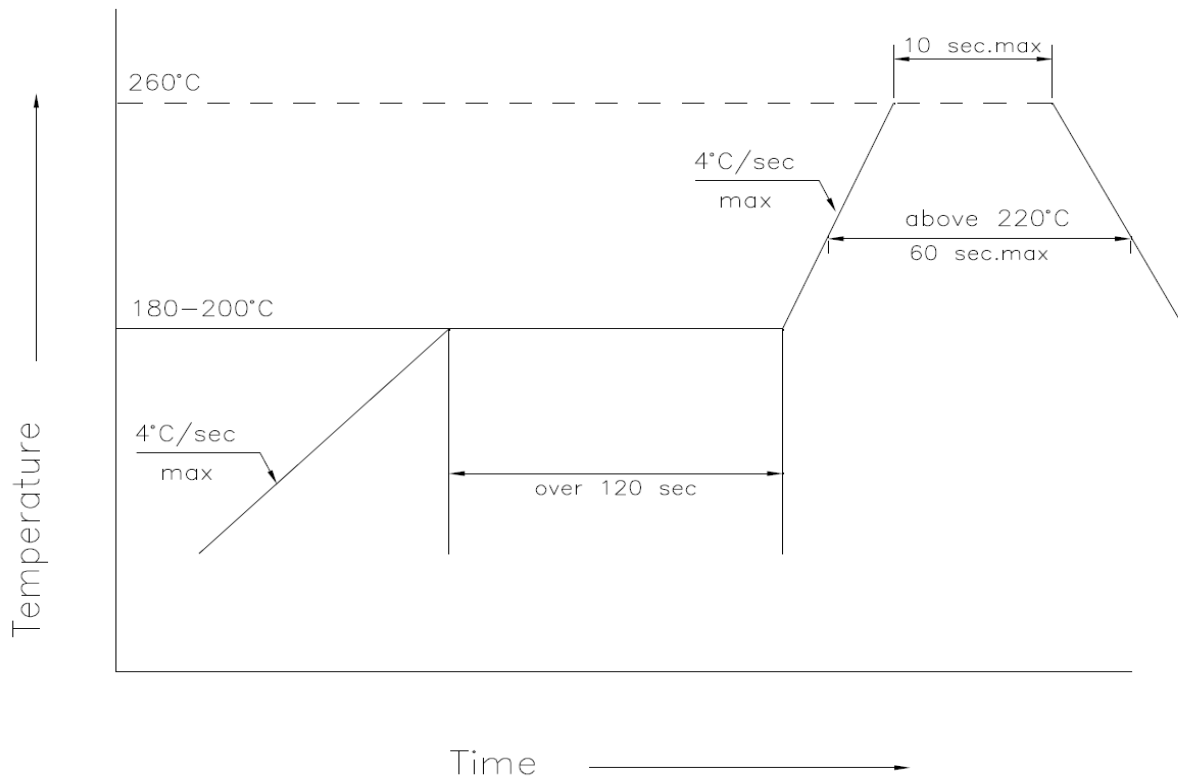

Figure 7: Reflow soldering profile

1. Reflow soldering should not be done more than twice
2. When soldering, do not put stress on the LEDs during heating

### **Soldering iron**

1. When hand soldering, the temperature of the iron must be  $\leq +300^{\circ}\text{C}$  for 3 seconds
2. Hand soldering should be performed only once.



## Handling Instructions

Plessey LEDs are not designed to operate with reverse bias.

Precautions are required to prevent reverse bias in applications and during handling.

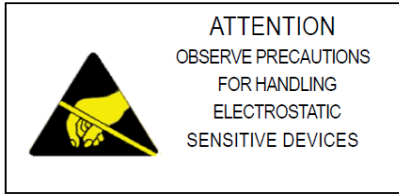

## Moisture Sensitivity

JEDEC Level	Floor life		Soak Requirements	
	Time	Conditions	Time	Conditions
4	72 hours	≤+30°C / 60% RH	96±2 hours	+30°C / 60% RH

## Packing Information

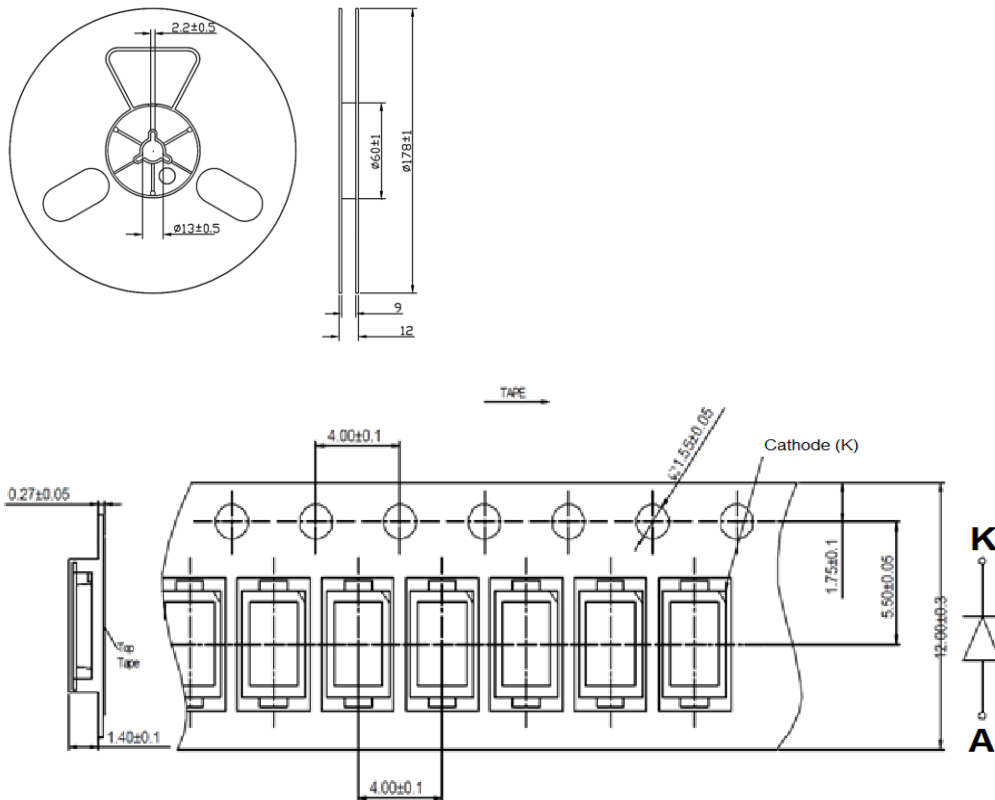

Figure 8: Reel Specification (units in mm)

## **Legal Notice**

Product information provided by Plessey Semiconductors Limited (“Plessey”) in this document is believed to be correct and accurate. Plessey reserves the right to change/correct the specifications and other data or information relating to products without notice but Plessey accepts no liability for errors that may appear in this document, howsoever occurring, or liability arising from the use or application of any information or data provided herein. Neither the supply of such information, nor the purchase or use of products conveys any licence or permission under patent, copyright, trademark or other intellectual property right of Plessey or third parties.

Products sold by Plessey are subject to its standard Terms and Conditions of Sale that are available on request. No warranty is given that products do not infringe the intellectual property rights of third parties, and furthermore, the use of products in certain ways or in combination with Plessey, or non-Plessey furnished equipments/components may infringe intellectual property rights of Plessey.

The purpose of this document is to provide information only and it may not be used, applied or reproduced (in whole or in part) for any purpose nor be taken as a representation relating to the products in question. No warranty or guarantee express or implied is made concerning the capability, performance or suitability of any product, and information concerning possible applications or methods of use is provided for guidance only and not as a recommendation. The user is solely responsible for determining the performance and suitability of the product in any application and checking that any specification or data it seeks to rely on has not been superseded.

Products are intended for normal commercial applications. For applications requiring unusual environmental requirements, extended temperature range, or high reliability capability (e.g. military or medical applications), special processing/testing/conditions of sale may be available on application to Plessey.

## **Contact**

Customer Enquiries/Sales

+44 1752 693000 | [sales@plesseysemi.com](mailto:sales@plesseysemi.com) | [www.plesseysemi.com](http://www.plesseysemi.com)

Plessey Semiconductors Ltd | Plymouth

Tamerton Road, Roborough

Plymouth, Devon

PL6 7BQ United Kingdom

## Данный компонент на территории Российской Федерации

### Вы можете приобрести в компании MosChip.

Для оперативного оформления запроса Вам необходимо перейти по данной ссылке:

<http://moschip.ru/get-element>

Вы можете разместить у нас заказ для любого Вашего проекта, будь то серийное производство или разработка единичного прибора.

В нашем ассортименте представлены ведущие мировые производители активных и пассивных электронных компонентов.

Нашей специализацией является поставка электронной компонентной базы двойного назначения, продукции таких производителей как XILINX, Intel (ex.ALTERA), Vicor, Microchip, Texas Instruments, Analog Devices, Mini-Circuits, Amphenol, Glenair.

Сотрудничество с глобальными дистрибьюторами электронных компонентов, предоставляет возможность заказывать и получать с международных складов практически любой перечень компонентов в оптимальные для Вас сроки.

На всех этапах разработки и производства наши партнеры могут получить квалифицированную поддержку опытных инженеров.

Система менеджмента качества компании отвечает требованиям в соответствии с ГОСТ Р ИСО 9001, ГОСТ РВ 0015-002 и ЭС РД 009

### Офис по работе с юридическими лицами:

105318, г.Москва, ул.Щербаковская д.3, офис 1107, 1118, ДЦ «Щербаковский»

Телефон: +7 495 668-12-70 (многоканальный)

Факс: +7 495 668-12-70 (доб.304)

E-mail: [info@moschip.ru](mailto:info@moschip.ru)

Skype отдела продаж:

moschip.ru

moschip.ru\_4

moschip.ru\_6

moschip.ru\_9