

1.5 A ultra low-dropout voltage regulator

Datasheet - production data

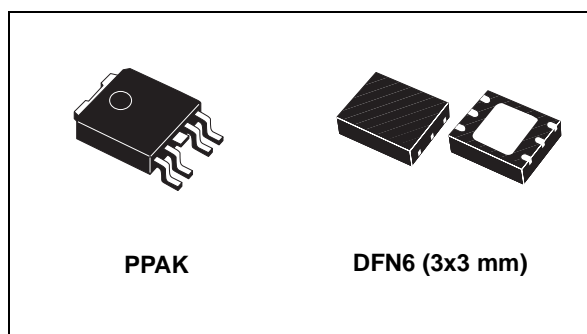

Applications

- Graphics processors
- PC add-in cards
- Microprocessor core voltage supply
- Low voltage digital ICs
- High efficiency linear power supplies
- SMPS post regulators

Description

The LD49150 is a high-bandwidth, low-dropout, 1.5 A voltage regulator, ideal for powering core voltages of low power microprocessors. The LD49150 implements a dual supply configuration, which guarantees a very low output impedance and a very fast transient response. The LD49150 requires a bias input supply and a main input supply, allowing ultra-low input voltages on the main supply rail. The input supply operates from 1.4 V to 5.5 V and the bias supply requires between 3 V and 6 V to work properly. The LD49150 offers fixed output voltages from 0.8 V to 1.8 V and adjustable output voltages starting from 0.8 V. The LD49150 requires a minimum output capacitance for stability, and works optimally with small ceramic capacitors.

Features

- Input voltage range:
 - $V_I = 1.4 \text{ V to } 5.5 \text{ V}$
 - $V_{BIAS} = 3 \text{ V to } 6 \text{ V}$
- Stable with ceramic capacitors
- $\pm 1.5\%$ initial tolerance
- Maximum dropout voltage ($V_I - V_O$) 200 mV over the operating temperature range
- Adjustable output voltage starting from 0.8 V
- Fast transient response (up to 10 MHz bandwidth)
- Excellent line and load regulation specifications
- Logic-controlled shutdown option
- Thermal shutdown and current limit protection
- Junction temperature range: $-25 \text{ }^\circ\text{C to } 125 \text{ }^\circ\text{C}$

Table 1. Device summary

Order codes		Output voltages
PPAK (tape and reel)	DFN6 (tape and reel) ⁽¹⁾	
LD49150PT08R		Adjustable from 0.8 V
LD49150PT10R	LD49150PU10R	1.0 V
LD49150PT12R	LD49150PU12R	1.2 V

1. Available on request.

Contents

- 1 Typical application circuits 3**
- 2 Alternative application circuits 4**
- 3 Pin configuration 5**
- 4 Diagram 6**
- 5 Maximum ratings 7**
- 6 Electrical characteristics 8**
- 7 Typical characteristics 9**
- 8 Application hints 12**
 - 8.1 Input supply voltage (VIN) 12
 - 8.2 Bias supply voltage (VBIAS) 12
 - 8.3 External capacitors 12
 - 8.4 Output capacitor 12
 - 8.5 Minimum load current 12
 - 8.6 Power sequencing recommendations 13
 - 8.7 Power dissipation/heatsinking 13
 - 8.8 PPAK package heatsinking 14
 - 8.9 Adjustable regulator design 14
 - 8.10 Enable 15
- 9 Package mechanical data 16**
- 10 Packaging mechanical data 21**
- 11 Revision history 23**



1 Typical application circuits

Figure 1. Adjustable version

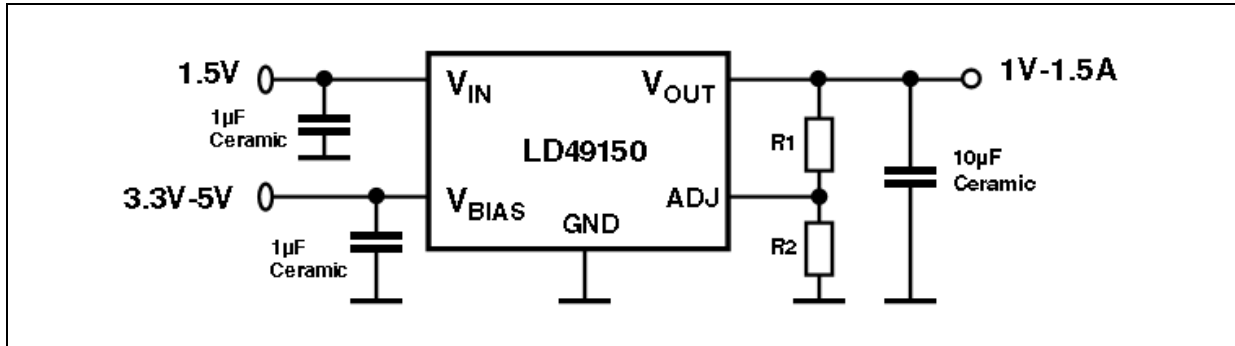
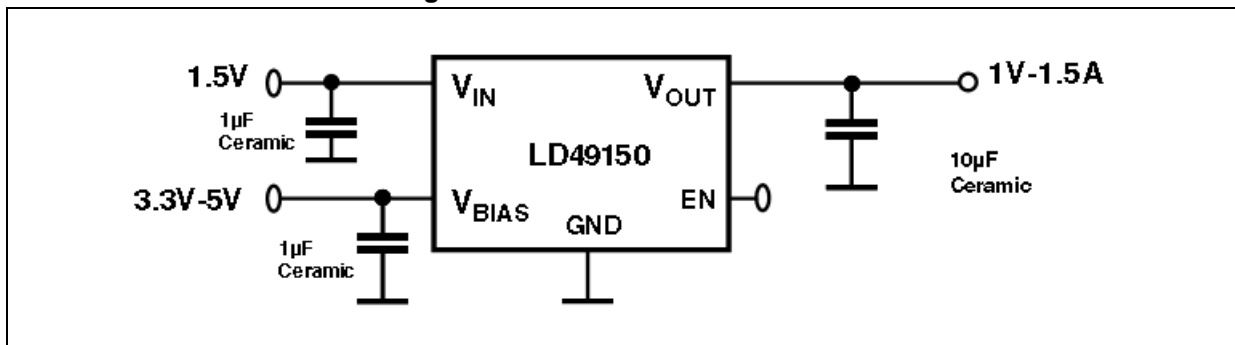

Figure 2. Fixed version with enable



2 Alternative application circuits

Figure 3. Single supply voltage solution

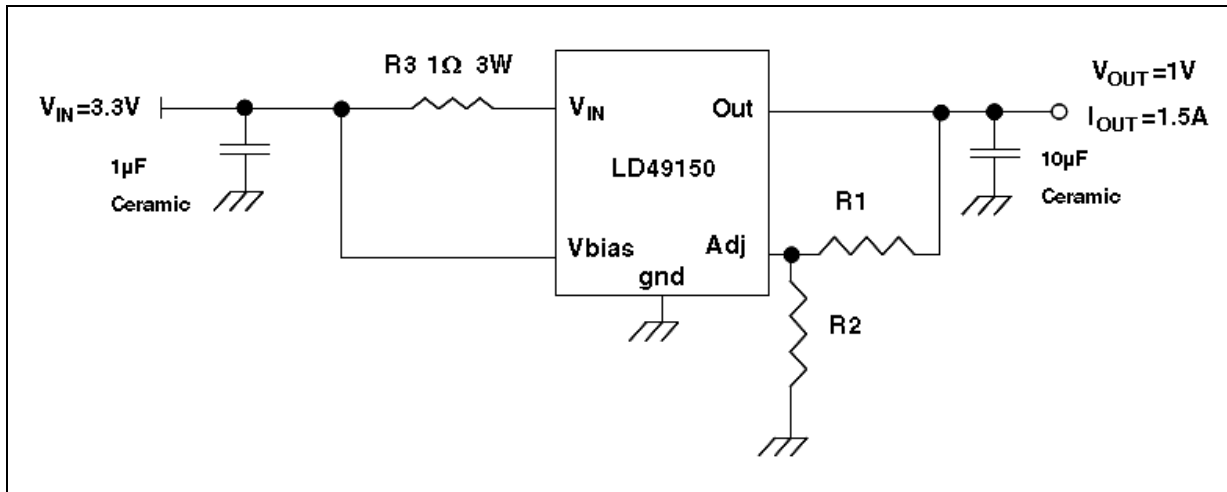
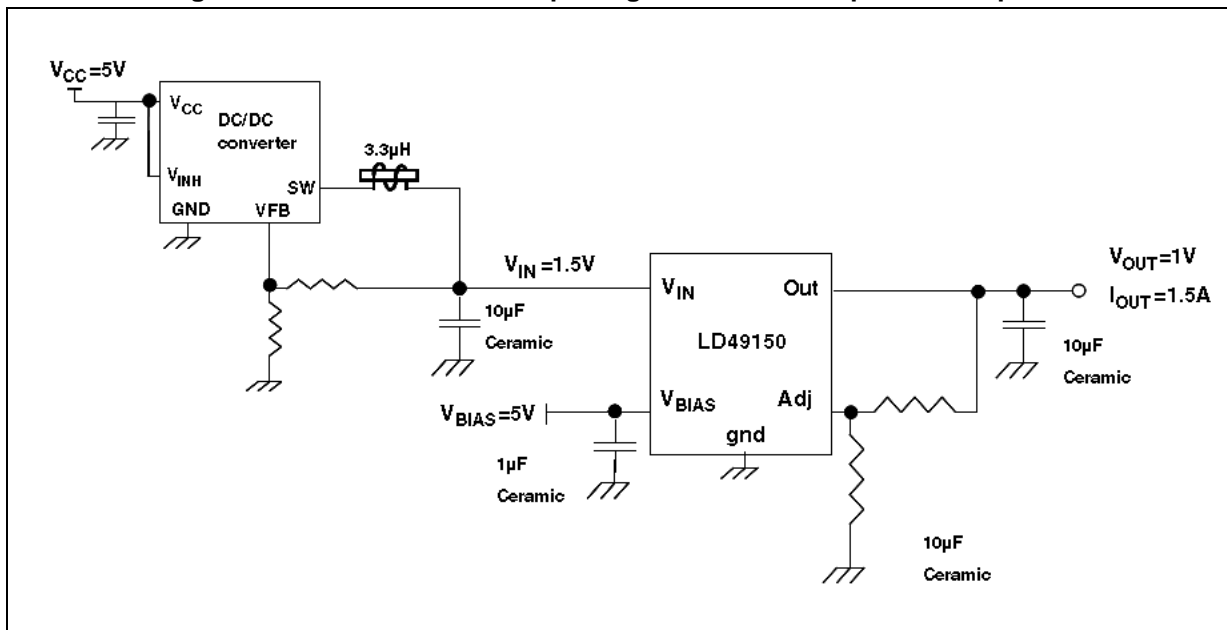

Figure 4. LD49150 and DC-DC pre-regulator to reduce power dissipation



3 Pin configuration

Figure 5. Pin connections (PPAK top view, DFN bottom view)

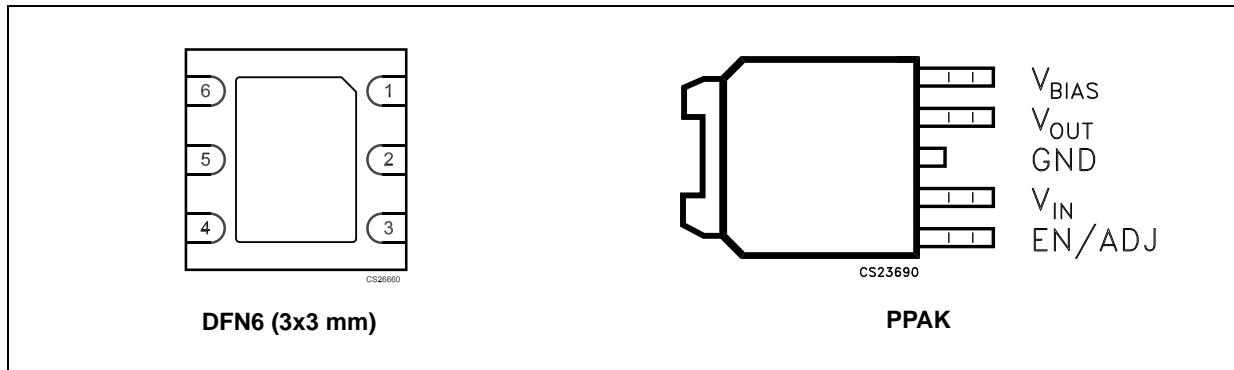
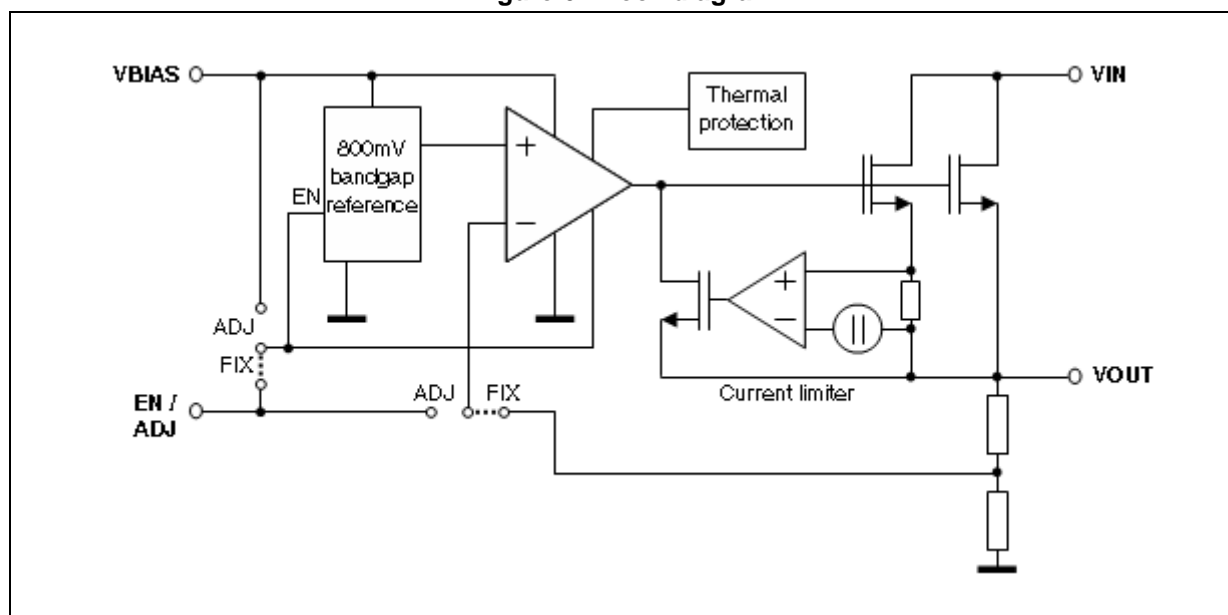

Table 2. Pin description

PPAK pin	DFN pin	Symbol	Note
1	2	EN	Enable (input): logic high = enable, logic low = shutdown
		ADJ	Adjustable regulator feedback input connected to resistor voltage divider
2	3	V_{IN}	Input of the voltage regulator
3	1	GND	Ground (tab is connected to ground)
4	4	V_{OUT}	Regulator output
5	6	V_{BIAS}	Input bias voltage powers circuitry on the regulator with the exception of the output power device
	5	N.C.	Not connected

4 Diagram

Figure 6. Block diagram



5 Maximum ratings

Table 3. Absolute maximum ratings⁽¹⁾

Symbol	Parameter	Value	Unit
V_{IN}	Supply voltage	-0.3 to 7	V
V_{OUT}	Output voltage	-0.3 to $V_{IN} + 0.3$ -0.3 to $V_{BIAS} + 0.3$	V
V_{BIAS}	Bias supply voltage	-0.3 to 7	V
V_{EN}	Enable input voltage	-0.3 to 7	V
P_D	Power dissipation	Internally limited	
T_{STG}	Storage temperature range	-50 to 150	°C

1. All values are referred to ground.

Note: Absolute maximum ratings are those values beyond which damage to the device may occur. Functional operation under these conditions is not implied.

Table 4. Operating ratings

Symbol	Parameter	Value	Unit
V_{IN}	Supply voltage	1.4 to 5.5	V
V_{OUT}	Output voltage	0.8 to 4.5	V
V_{BIAS}	Bias supply voltage	3 to 6	V
V_{EN}	Enable input voltage	0 to V_{BIAS}	V
T_J	Junction temperature range	-25 to 125	°C

6 Electrical characteristics

$T_J = -25\text{ °C}$ to 125 °C ; $V_{BIAS} = V_O + 2.1\text{ V}$ ⁽¹⁾; $V_I = V_O + 1\text{ V}$; $V_{EN} = V_{BIAS}$ ⁽²⁾; $I_O = 10\text{ mA}$; $C_I = 1\text{ }\mu\text{F}$; $C_O = 10\text{ }\mu\text{F}$; $C_{BIAS} = 1\text{ }\mu\text{F}$; unless otherwise specified. Typical values refer to $T_J = 25\text{ °C}$.

Table 5. Electrical characteristics

Symbol	Parameter	Test conditions	Min.	Typ.	Max.	Unit
V_O	Output voltage accuracy	$T_J = 25\text{ °C}$, fixed voltage option	-1.5		1.5	%
		$T_J = -25\text{ °C}$ to 125 °C	-3		3	
V_{LINE}	Line regulation	$V_I = V_O + 1\text{ V}$ to 5.5 V	-0.1		0.1	%/V
V_{LOAD}	Load regulation	$I_L = 0\text{ mA}$ to 1.5 A , $V_{BIAS} \geq 3\text{ V}$			1	%
V_{DROP}	Dropout voltage ($V_I - V_O$)	$I_L = 1.5\text{ A}$			200	mV
V_{DROP}	Dropout voltage ($V_{BIAS} - V_O$)	$I_L = 1.5\text{ A}$ ⁽¹⁾		1.5	2.1	V
I_{GND}	Ground pin current	$I_L = 0\text{ mA}$		4	6	mA
		$I_L = 1.5\text{ A}$		4	6	
I_{GND_SHD}	Ground pin current in shutdown	$V_{EN} \leq 0.4\text{ V}$ ⁽²⁾			5	μA
I_{VBIAS}	Current through V_{BIAS}	$I_L = 0\text{ mA}$		3	5	mA
		$I_L = 1.5\text{ A}$		3	5	
I_L	Current limit	$V_O = 0\text{ V}$	2.5			A
Enable input ⁽²⁾						
V_{EN}	Enable input threshold (fixed voltage only)	Regulator enable	1.4			V
		Regulator shutdown			0.4	
I_{EN}	Enable pin input current			0.1	1	μA
Reference						
V_{REF}	Reference voltage	$T_J = 25\text{ °C}$	0.788	0.8	0.812	V
		$T_J = -25\text{ °C}$ to 125 °C	0.776	0.8	0.824	
SVR	Supply voltage rejection	$V_I = 2.5\text{ V} \pm 0.5\text{ V}$, $V_O = 1\text{ V}$, $F = 120\text{ Hz}$, $V_{BIAS} = 3.3\text{ V}$		68		dB

1. For $V_O \leq 1\text{ V}$, V_{BIAS} dropout specification is not applied due to 3 V minimum V_{BIAS} input.

2. Fixed output voltage version only.

7 Typical characteristics

Figure 7. Reference voltage vs. temperature

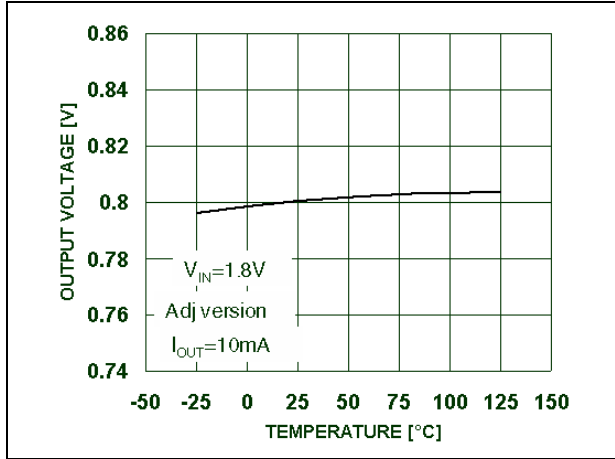

Figure 8. Output voltage vs. temperature

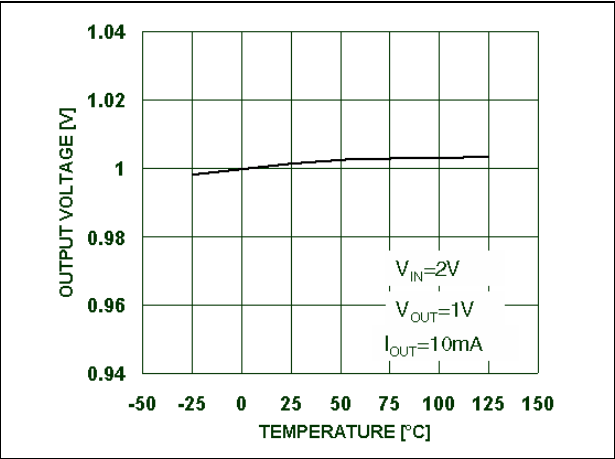

Figure 9. Load regulation vs. temperature

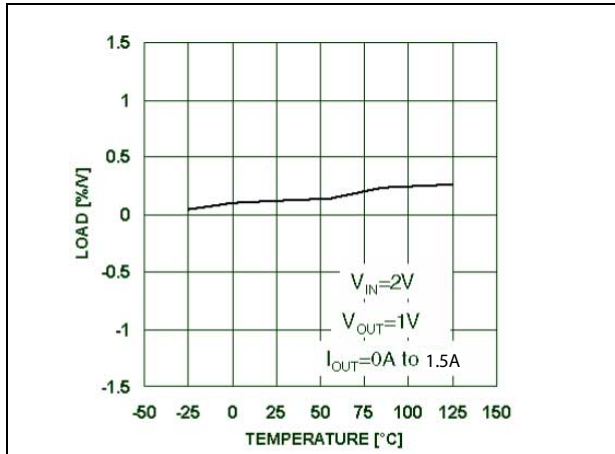

Figure 10. Line regulation vs. temperature

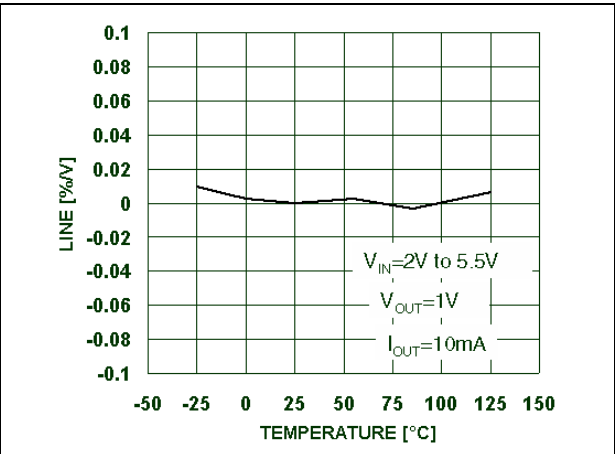

Figure 11. Output voltage vs. input voltage

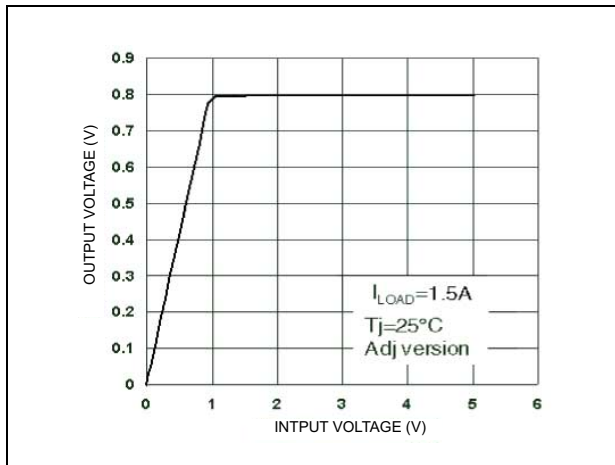

Figure 12. Dropout voltage ($V_{IN}-V_{OUT}$) vs. temperature

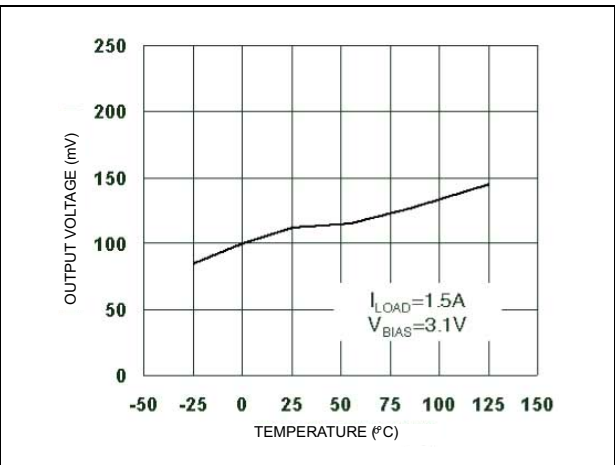

Figure 13. V_{BIAS} pin current vs. temperature

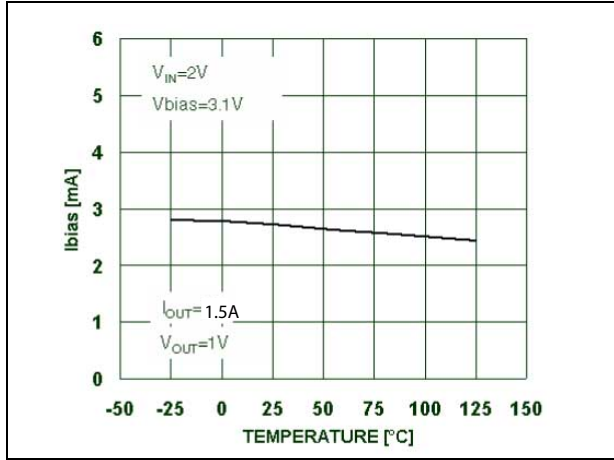

Figure 14. Noise vs. frequency

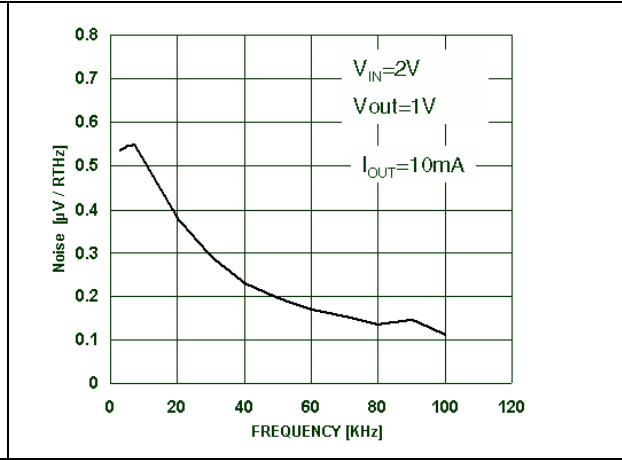

Figure 15. Quiescent current vs. temperature

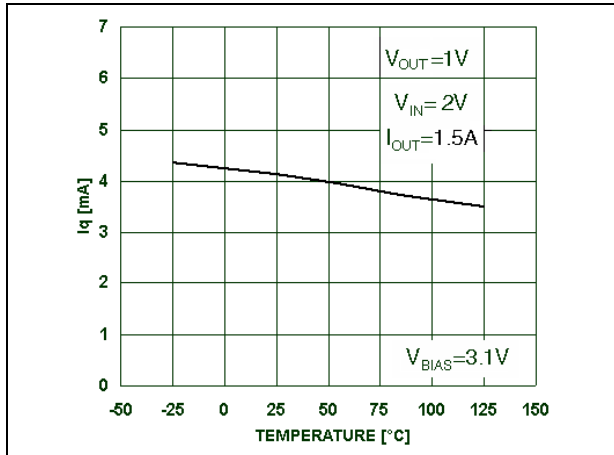

Figure 16. Supply voltage rejection vs. output current

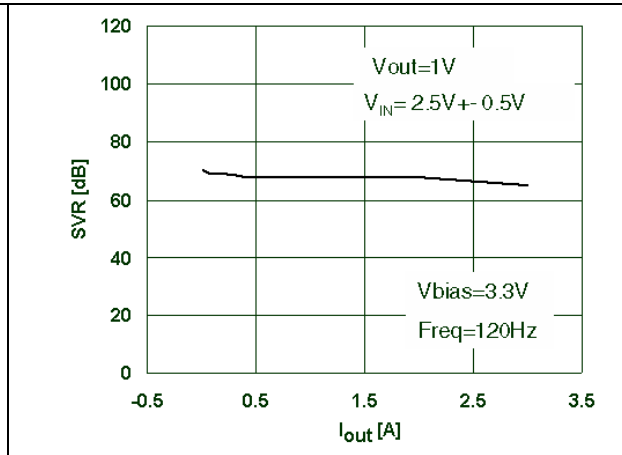

Figure 17. Stability region vs. C_{OUT} and high ESR

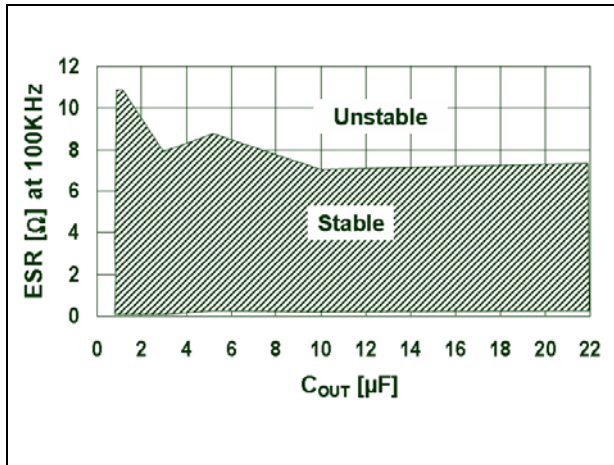

Figure 18. Stable region vs. C_{OUT} and low ESR

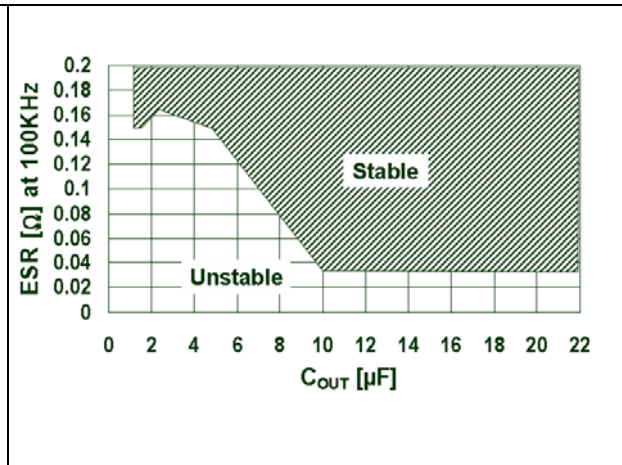

Figure 19. V_{BIAS} and V_{IN} start-up transient response (V_{IN} and V_{BIAS} startup at the same time)

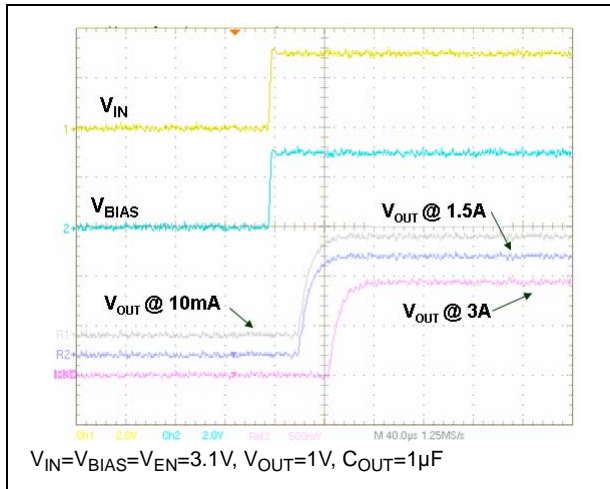

Figure 20. V_{IN} start-up transient response (V_{BIAS} startup before than V_{IN}) $T_{rise} = 300 µs$

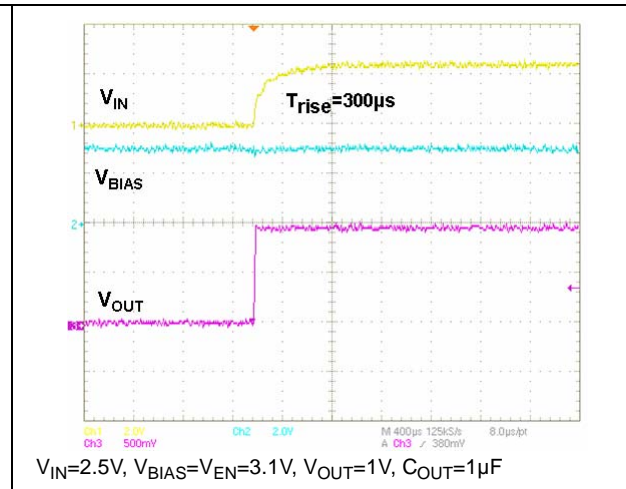

Figure 21. V_{IN} start-up transient response (V_{BIAS} startup before than V_{IN}) $T_{rise} = 30 µs$

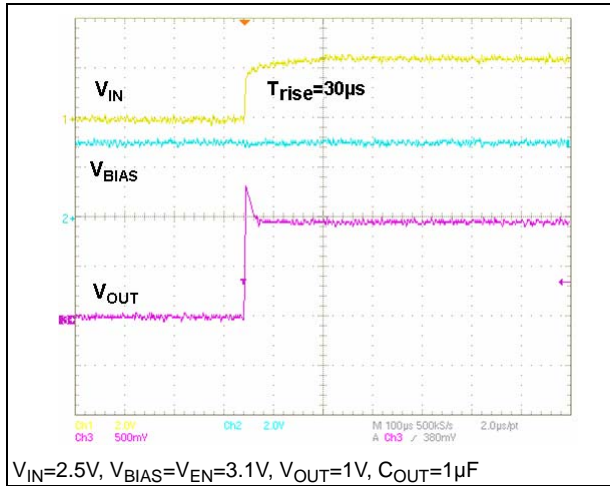
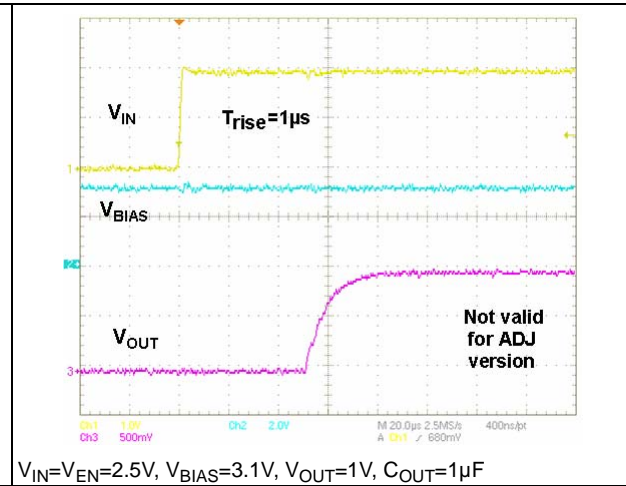

Figure 22. V_{IN} start-up transient response (V_{BIAS} startup before than V_{IN} and $V_{EN}=V_{IN}$)



8 Application hints

The LD49150 is a low-dropout linear regulator, designed for high-current applications requiring a fast transient response. The LD49150 has separate input and bias voltage ports, in order to reduce dropout voltage. Thanks to the LD49150, a minimum quantity of external components is required.

8.1 Input supply voltage (V_{IN})

V_{IN} provides the LD49150 with power input current. The minimum input voltage can be as low as 1.4 V, allowing conversion from very low voltage supplies to achieve low output voltage levels and low power dissipation.

8.2 Bias supply voltage (V_{BIAS})

The LD49150 control circuitry is supplied by V_{BIAS} pin, which requires a very low bias current (3 mA typ.) even at the maximum output current level (1.5 A). A bypass capacitor on V_{BIAS} pin improves the LD49150 performance during line and load transient. The small ceramic capacitor from V_{BIAS} to ground reduces high frequency noise that could be injected into the control circuitry. In typical applications, one ceramic chip capacitor of 1 μ F may be used. V_{BIAS} input voltage has to be 2.1 V above the output voltage, with a minimum V_{BIAS} input voltage of 3 V.

8.3 External capacitors

To assure regulator stability, input and output capacitors are required as shown in [Section 1](#).

8.4 Output capacitor

The LD49150 requires a minimum output capacitance to maintain stability. At least 1 μ F ceramic chip capacitor is required. However, a specific capacitor selection assures the transient response. 1 μ F ceramic chip capacitor satisfies most applications but 10 μ F guarantees a better transient performance. In applications where V_{IN} level is close to the maximum operating voltage ($V_{IN} > 4$ V), a minimum 10 μ F output capacitor avoids overvoltage stress on the input/output power pins during short-circuit conditions due to parasitic inductive effect. The output capacitor has to be as closer as possible to the LD49150 output pin. ESR output capacitor (equivalent series resistance) has to be within the stable region as shown in [Section 7](#). Both ceramic and tantalum capacitors are suitable.

8.5 Minimum load current

The LD49150 does not require a minimum load to maintain the output voltage regulation.

8.6 Power sequencing recommendations

To assure the correct biasing and settling of the regulator internal circuitry during the start-up phase, and to avoid overvoltage spikes on the output, the correct power sequencing has to be provided.

As general rule, V_{IN} and V_{INH} signal timings should be chosen properly, so that they are applied to the device after V_{BIAS} voltage has already been settled on its minimum operative value (see [Section 8.2](#)). This can be achieved, for instance, by avoiding too slow V_{BIAS} rising edges ($T_r > 10$ ms).

Provided that the above condition is satisfied, when fast V_{IN} transient input ($T_r < 100$ μ s) is present, a smooth startup, with limited overvoltage on the output, can be achieved by V_{IN} and V_{BIAS} voltage simultaneously (refer to [Figure 20](#), [Figure 21](#) and [Figure 22](#)).

In the fixed voltage version, overvoltage spikes can be reduced during very fast startup ($T_r \ll 100$ μ s) by pulling V_{EN} pin up to V_{IN} voltage (see [Figure 23](#)).

8.7 Power dissipation/heatsinking

In relation to the maximum power dissipation and maximum ambient temperature of the application, a heatsink may be required. Junction temperature has to be within the specified range under operating conditions. The total power dissipation of the device is given by:

Equation 1

$$P_D = V_{IN} \times I_{IN} + V_{BIAS} \times I_{BIAS} - V_{OUT} \times I_{OUT}$$

where:

- V_{IN} = input supply voltage
- V_{BIAS} = bias supply voltage
- V_{OUT} = output voltage
- I_{OUT} = load current

The required θ_{SA} thermal resistance for the heatsink is given by the following formula:

Equation 2

$$\theta_{SA} = (T_J - T_A/P_D) - (\theta_{JC} + \theta_{CS})$$

T_{Rmax} , the maximum allowed temperature rise depends on T_{Amax} , the maximum ambient temperature of the application, and T_{Jmax} , the maximum allowable junction temperature:

Equation 3

$$T_{Rmax} = T_{Jmax} - T_{Amax}$$

θ_{JA} , the maximum allowable value for junction-to-ambient thermal resistance can be calculated as follows:

Equation 4

$$\theta_{JAmax} = T_{Rmax} / P_D$$

The thermal resistance depends on the amount of copper area or heatsink, and on the air flow. If θ_{JA} the maximum allowable value is ≥ 100 $^{\circ}$ C/W for the PPAK package, no heatsink is

needed since the package can dissipate enough heat to satisfy these requirements. If the allowable θ_{JA} value falls below these limits, a heatsink is required as described below.

8.8 PPAK package heatsinking

The PPAK package uses the copper plane on the PCB as a heatsink. The tab of this package is soldered onto the copper plane for the heatsinking. PCB ground plane can be used as a heatsink. This area can be the inner GND layer of a multi-layer PCB, or, in a dual-layer PCB, it can be an unbroken GND area on the bottom layer, thermally connected to the tab through-via holes.

Figure 23 shows θ_{JA} curve for PPAK package for different copper area sizes, using a typical PCB: thickness 1/16 G10 FR4.

Figure 23. θ_{JA} vs. copper area for PPAK package

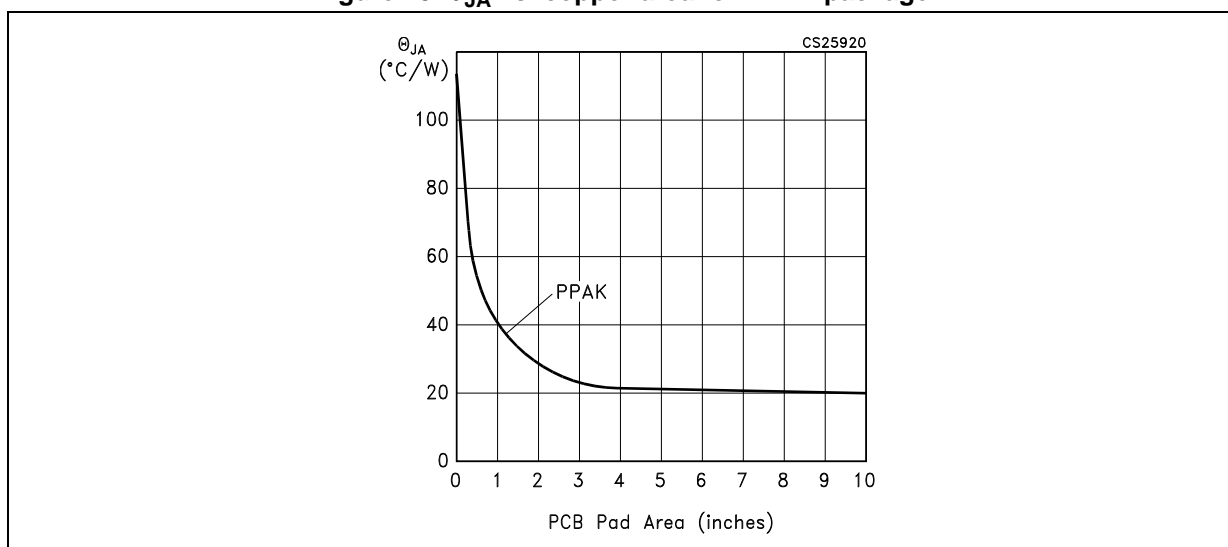

8.9 Adjustable regulator design

The LD49150 adjustable version allows the output voltage to be fixed anywhere between 0.8 V and 4.5 V using two resistors as shown in the typical application circuit. For example, to fix R_1 resistor value between V_{OUT} and ADJ pin, the resistor value between ADJ and GND (R_2) is calculated as follows:

$$R_2 = R_1 [0.8/(V_{OUT} - 0.8)]$$

where V_{OUT} is the desired output voltage.

R_1 values should be lower than 10 k Ω to obtain a better load transient performance. Higher values up to 100 k Ω are suitable.

8.10 Enable

The LD49150 fixed output voltage version features an active high enable input (EN) that allows the on-off control of the regulator. EN input threshold is guaranteed between 0.4 V and 1.4 V. The regulator is in shutdown mode when $V_{EN} < 0.4$ V and it is in operating mode (V_{OUT} activated) when $V_{EN} > 1.4$ V. If it is not in use, EN pin has to be tied directly to V_{IN} to keep the regulator continuously activated. En pin has not to be left with high impedance.

9 Package mechanical data

In order to meet environmental requirements, ST offers these devices in different grades of ECOPACK[®] packages, depending on their level of environmental compliance. ECOPACK[®] specifications, grade definitions and product status are available at: www.st.com. ECOPACK[®] is an ST trademark.

Figure 24. PPAK drawing

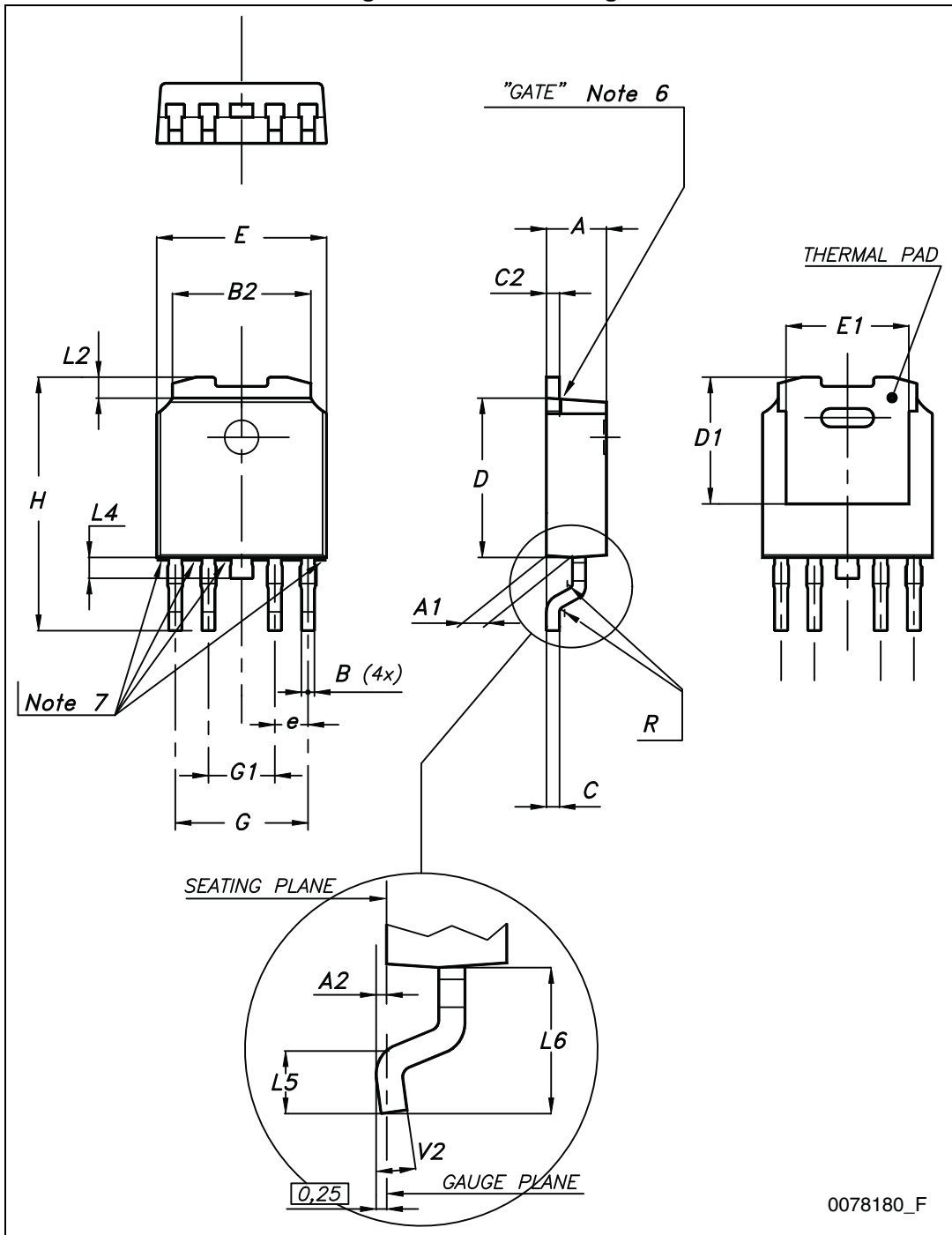

Table 6. PPAK mechanical data

Dim.	mm		
	Min.	Typ.	Max.
A	2.2		2.4
A1	0.9		1.1
A2	0.03		0.23
B	0.4		0.6
B2	5.2		5.4
C	0.45		0.6
C2	0.48		0.6
D	6		6.2
D1		5.1	
E	6.4		6.6
E1		4.7	
e		1.27	
G	4.9		5.25
G1	2.38		2.7
H	9.35		10.1
L2		0.8	1
L4	0.6		1
L5	1		
L6		2.8	
R		0.20	
V2	0°		8°

Figure 25. DFN6 (3x3 mm) drawing

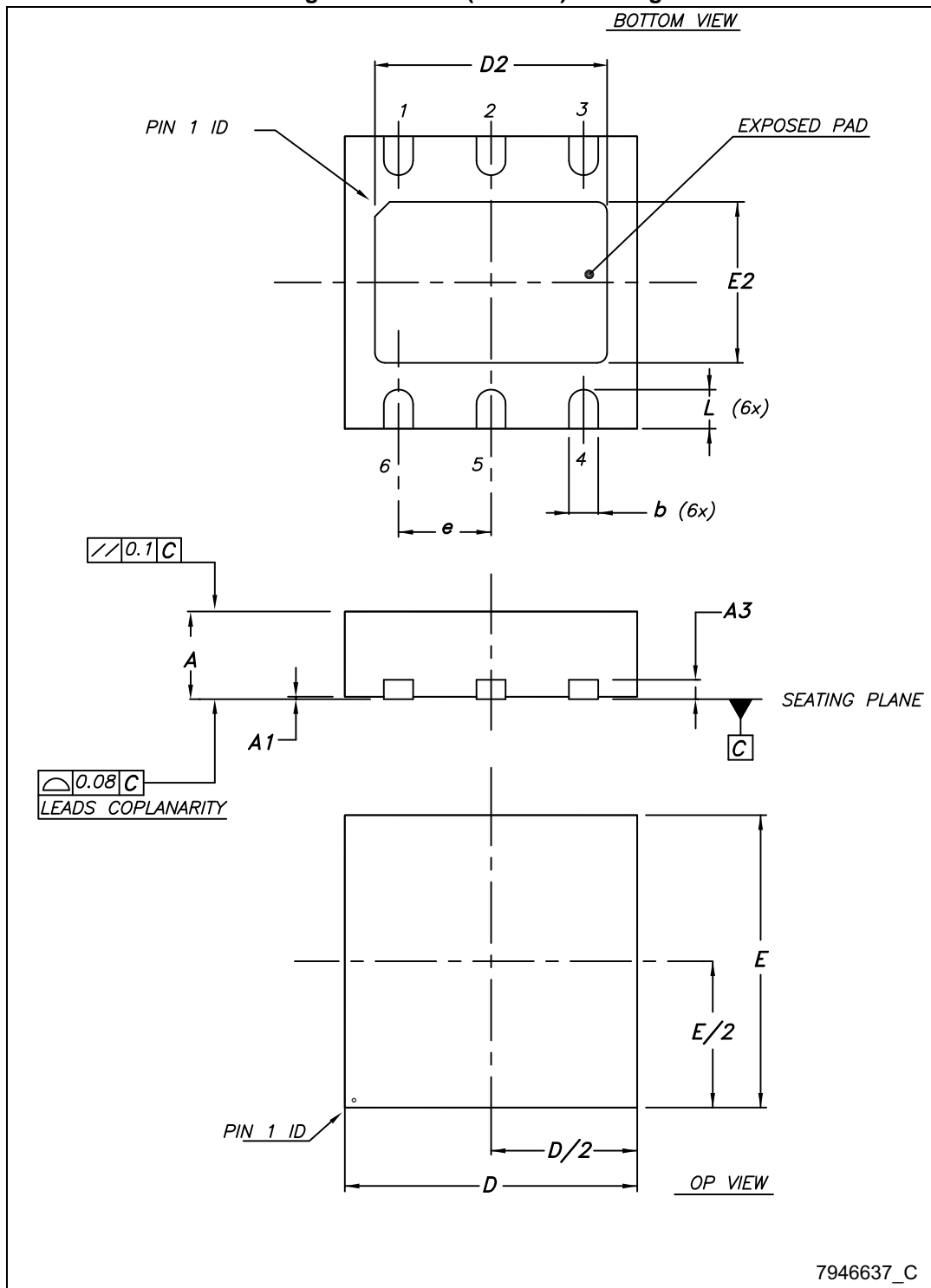
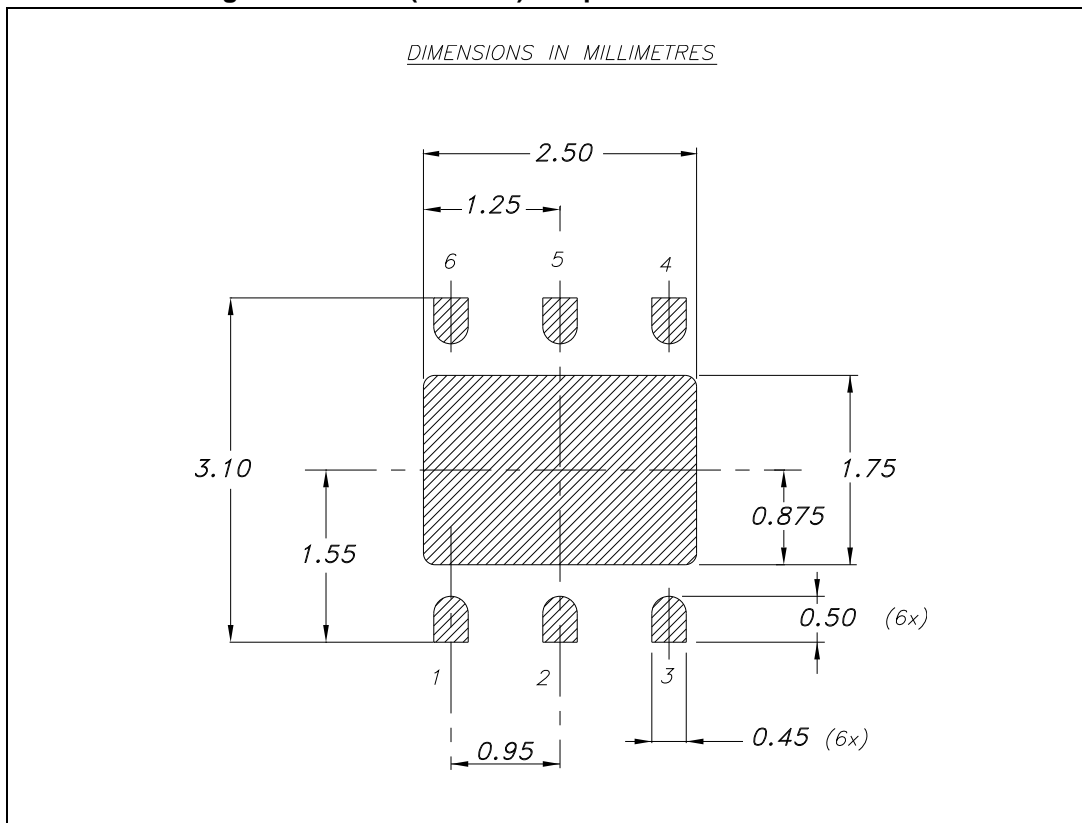

Table 7. DFN6 (3x3 mm) mechanical data

Dim.	mm		
	Min.	Typ.	Max.
A	0.80		1
A1	0	0.02	0.05
A3		0.20	
b	0.23		0.45
D	2.90	3	3.10
D2	2.23		2.50
E	2.90	3	3.10
E2	1.50		1.75
e		0.95	
L	0.30	0.40	0.50

Figure 26. DFN6 (3x3 mm) footprint recommended data



10 Packaging mechanical data

Figure 27. DFN6 (3x3 mm) tape

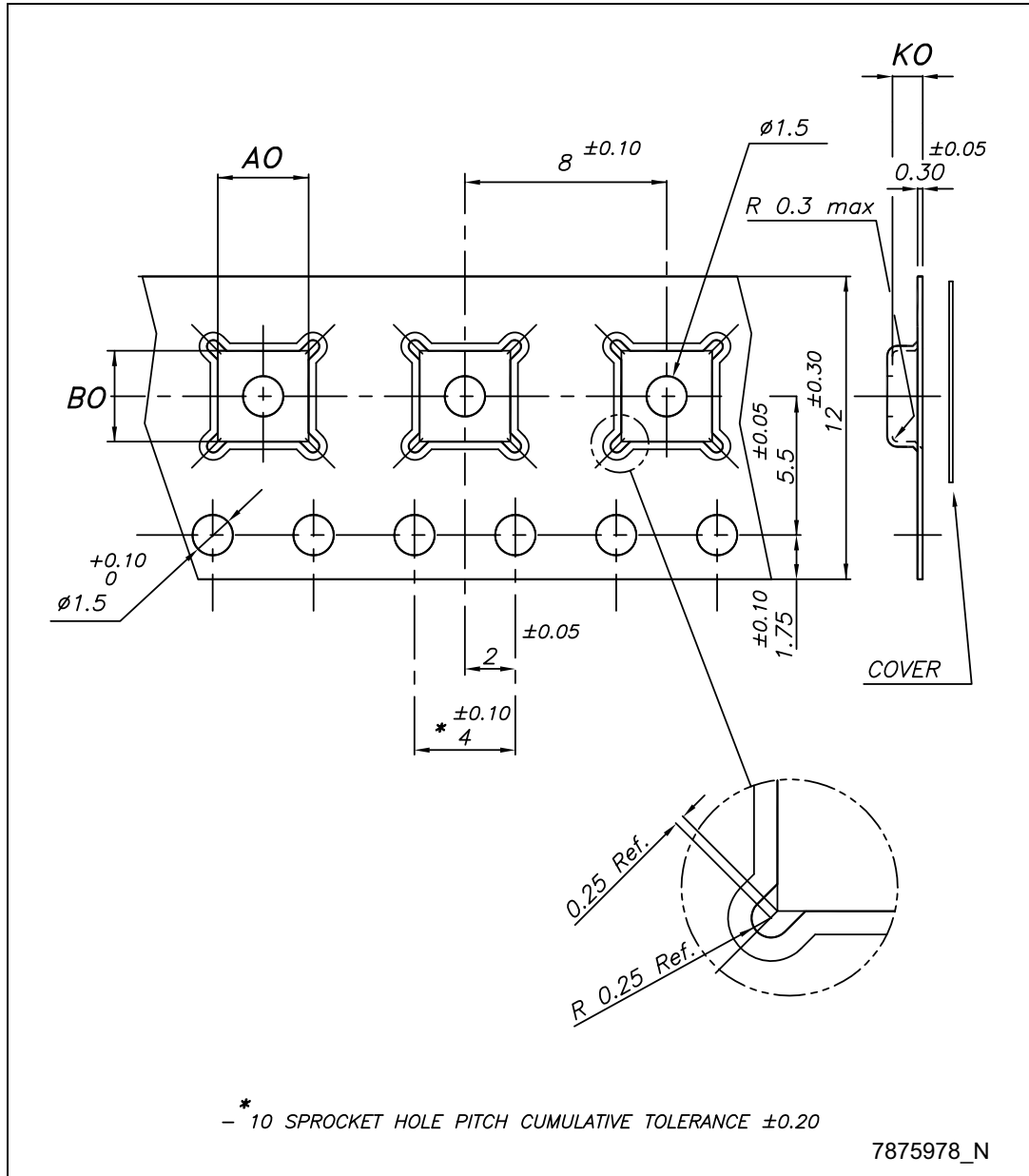

Figure 28. DFN6 (3x3 mm) reel

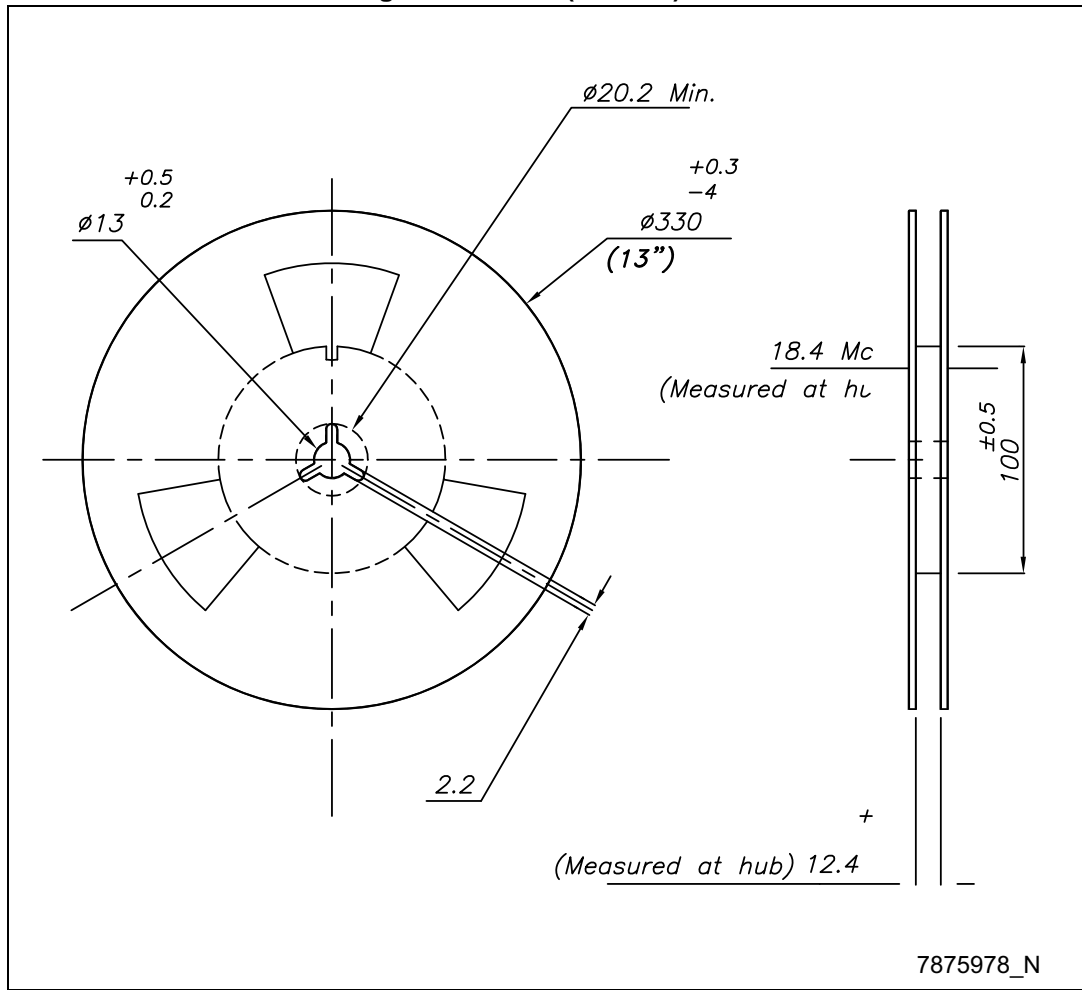

Table 8. DFN6 (3x3 mm) tape and reel mechanical data

Dim.	mm		
	Min.	Typ.	Max.
A0	3.20	3.30	3.40
B0	3.20	3.30	3.40
K0	1	1.10	1.20

11 Revision history

Table 9. Document revision history

Date	Revision	Changes
18-Apr-2007	1	Initial release.
12-Jan-2009	2	Added new package DFN6 (3x3 mm) and mechanical data.
29-Jun-2010	3	Modified Section 8.6: Power sequencing recommendations on page 13 .
26-May-2014	4	Changed the part numbers LD49150xx08, LD49150xx10 and LD49150xx12 to LD49150. Changed the title. Updated the description in cover page, Table 1: Device summary , Section 7: Typical characteristics , Section 8: Application hints , Section 9: Package mechanical data . Added Section 10: Packaging mechanical data . Minor text changes.

Please Read Carefully:

Information in this document is provided solely in connection with ST products. STMicroelectronics NV and its subsidiaries ("ST") reserve the right to make changes, corrections, modifications or improvements, to this document, and the products and services described herein at any time, without notice.

All ST products are sold pursuant to ST's terms and conditions of sale.

Purchasers are solely responsible for the choice, selection and use of the ST products and services described herein, and ST assumes no liability whatsoever relating to the choice, selection or use of the ST products and services described herein.

No license, express or implied, by estoppel or otherwise, to any intellectual property rights is granted under this document. If any part of this document refers to any third party products or services it shall not be deemed a license grant by ST for the use of such third party products or services, or any intellectual property contained therein or considered as a warranty covering the use in any manner whatsoever of such third party products or services or any intellectual property contained therein.

UNLESS OTHERWISE SET FORTH IN ST'S TERMS AND CONDITIONS OF SALE ST DISCLAIMS ANY EXPRESS OR IMPLIED WARRANTY WITH RESPECT TO THE USE AND/OR SALE OF ST PRODUCTS INCLUDING WITHOUT LIMITATION IMPLIED WARRANTIES OF MERCHANTABILITY, FITNESS FOR A PARTICULAR PURPOSE (AND THEIR EQUIVALENTS UNDER THE LAWS OF ANY JURISDICTION), OR INFRINGEMENT OF ANY PATENT, COPYRIGHT OR OTHER INTELLECTUAL PROPERTY RIGHT.

ST PRODUCTS ARE NOT DESIGNED OR AUTHORIZED FOR USE IN: (A) SAFETY CRITICAL APPLICATIONS SUCH AS LIFE SUPPORTING, ACTIVE IMPLANTED DEVICES OR SYSTEMS WITH PRODUCT FUNCTIONAL SAFETY REQUIREMENTS; (B) AERONAUTIC APPLICATIONS; (C) AUTOMOTIVE APPLICATIONS OR ENVIRONMENTS, AND/OR (D) AEROSPACE APPLICATIONS OR ENVIRONMENTS. WHERE ST PRODUCTS ARE NOT DESIGNED FOR SUCH USE, THE PURCHASER SHALL USE PRODUCTS AT PURCHASER'S SOLE RISK, EVEN IF ST HAS BEEN INFORMED IN WRITING OF SUCH USAGE, UNLESS A PRODUCT IS EXPRESSLY DESIGNATED BY ST AS BEING INTENDED FOR "AUTOMOTIVE, AUTOMOTIVE SAFETY OR MEDICAL" INDUSTRY DOMAINS ACCORDING TO ST PRODUCT DESIGN SPECIFICATIONS. PRODUCTS FORMALLY ESCC, QML OR JAN QUALIFIED ARE DEEMED SUITABLE FOR USE IN AEROSPACE BY THE CORRESPONDING GOVERNMENTAL AGENCY.

Resale of ST products with provisions different from the statements and/or technical features set forth in this document shall immediately void any warranty granted by ST for the ST product or service described herein and shall not create or extend in any manner whatsoever, any liability of ST.

ST and the ST logo are trademarks or registered trademarks of ST in various countries.

Information in this document supersedes and replaces all information previously supplied.

The ST logo is a registered trademark of STMicroelectronics. All other names are the property of their respective owners.

© 2014 STMicroelectronics - All rights reserved

STMicroelectronics group of companies

Australia - Belgium - Brazil - Canada - China - Czech Republic - Finland - France - Germany - Hong Kong - India - Israel - Italy - Japan - Malaysia - Malta - Morocco - Philippines - Singapore - Spain - Sweden - Switzerland - United Kingdom - United States of America

www.st.com

Данный компонент на территории Российской Федерации

Вы можете приобрести в компании MosChip.

Для оперативного оформления запроса Вам необходимо перейти по данной ссылке:

<http://moschip.ru/get-element>

Вы можете разместить у нас заказ для любого Вашего проекта, будь то серийное производство или разработка единичного прибора.

В нашем ассортименте представлены ведущие мировые производители активных и пассивных электронных компонентов.

Нашей специализацией является поставка электронной компонентной базы двойного назначения, продукции таких производителей как XILINX, Intel (ex.ALTERA), Vicor, Microchip, Texas Instruments, Analog Devices, Mini-Circuits, Amphenol, Glenair.

Сотрудничество с глобальными дистрибьюторами электронных компонентов, предоставляет возможность заказывать и получать с международных складов практически любой перечень компонентов в оптимальные для Вас сроки.

На всех этапах разработки и производства наши партнеры могут получить квалифицированную поддержку опытных инженеров.

Система менеджмента качества компании отвечает требованиям в соответствии с ГОСТ Р ИСО 9001, ГОСТ РВ 0015-002 и ЭС РД 009

Офис по работе с юридическими лицами:

105318, г.Москва, ул.Щербаковская д.3, офис 1107, 1118, ДЦ «Щербаковский»

Телефон: +7 495 668-12-70 (многоканальный)

Факс: +7 495 668-12-70 (доб.304)

E-mail: info@moschip.ru

Skype отдела продаж:

moschip.ru

moschip.ru_4

moschip.ru_6

moschip.ru_9