

Single IDC Contact 12-18 AWG

9177-500

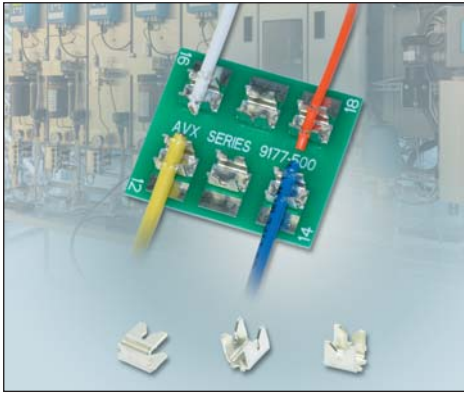

AVX's STRIPT™, insulation displacement naked contact technology provides cost effective, insulator-less, wire-to-board connection for discrete wire applications. Designed from the ground up to function just like a traditional insulated connector, these UL certified contacts have been industry proven for many years. This 9177-500 series has been designed to support the larger wire gauges from a robustness and current rating perspective.

APPLICATIONS

- Industrial motor controls, drives & pumps
- Commercial building wiring and electrical systems
- Outdoor/Transportation lighting
- Solar and alternative energy

FEATURES AND BENEFITS

- Proven “gas tight” cold welded wire termination
- Redundant contact systems provides enhanced wire retention and high current carrying capabilities
- Cost effective STRIPT™ insulator-less contact system

ELECTRICAL

- Current Rating: 15
- Voltage Rating: 600 VAC

ENVIRONMENTAL

- Operating Temperature: -40°C to +125°C

MECHANICAL

- Contact Material: Phosphor Bronze
- Contact Plating: Pure tin over nickel
- Durability: 3 termination cycles

HOW TO ORDER

70
Prefix
70 = Contact

9177
Series

001
Number of Ways
001 = 1

5XX
Wire Gauge Size
591 = 12AWG Stranded and Solid
501 = 14AWG Stranded and Solid
512 = 16AWG Stranded and Solid
522 = 18AWG Stranded and Solid

006
Plating Option
006 = Pure Tin all over



Certification: UL File #E90723

Single IDC Contact 12-18 AWG

9177-500

CONTACT DETAILS

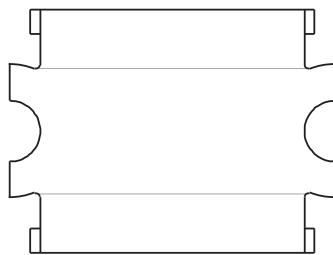
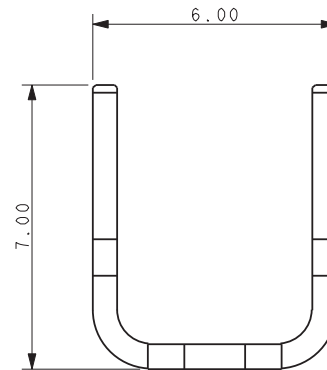
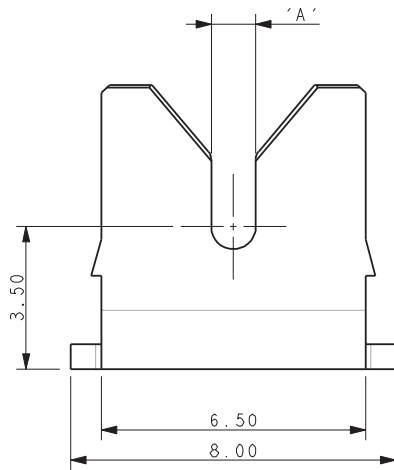

Code	Accepted Wire Gauge	A
591	12AWG Stranded and Solid	1.50
501	14AWG Stranded and Solid	1.10
512	16AWG Stranded and Solid	0.82
522	18AWG Stranded and Solid	0.72

NOTES:

- CONNECTOR FO IDC WIRE TO BOARD CONNECTION.
- CONTACT MATERIAL: PHOSPHORE BRONZE.
- CONTACT PLATING: PURE TIN.
- CONTACTS DESIGNED TO ACCEPT BETWEEN 12 AND 18 GAUGE STANDED WIRE, SEE TABLE.
- ALL DIMENSIONS FOR REFERENCE UNLESS OTHERWISE STATED.
- FOR FULL PRODUCT SPECIFICATIONS REFER TO AVX SPECIFICATION 201-01-208 AND APPLICATION NOTES 201-01-209.
- SMT PCB LAYOUT, REFER TO PAGE 3.
- PACKING IN TAPE AND REEL, QUANTITY PER REEL 700.
- ASSEMBLY TOOLING ON PAGE 4.
- UL REFERENCE E90723 (US AND CANADA).

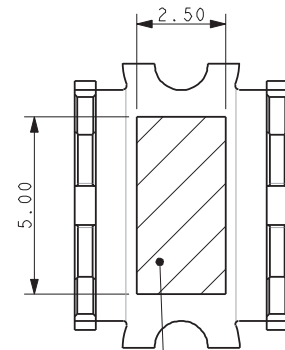

PICK AND PLACE AREA

PACKING DETAILS

REEL QTY	700
LEADER	480MM
TRAILER	120MM

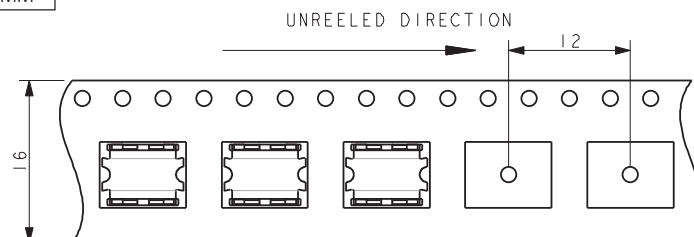
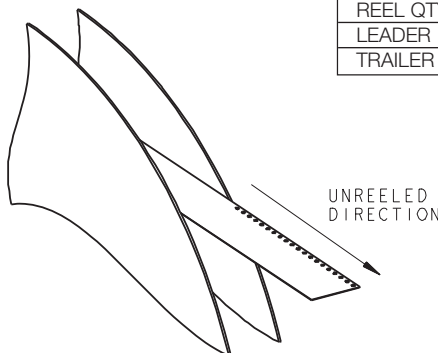

Single IDC Contact 12-18 AWG

9177-500

12-18 AWG IDC WIRE TO BOARD CONNECTOR SINGLE CONTACT

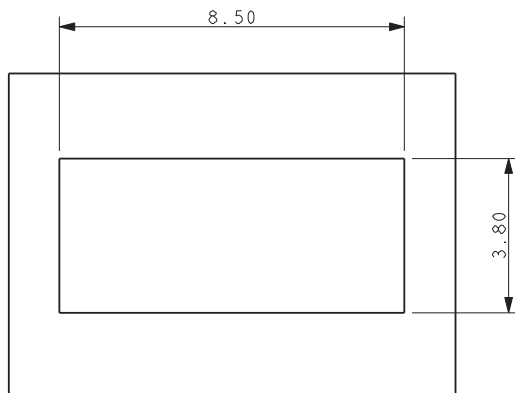

SUGGESTED PCB LAYOUT

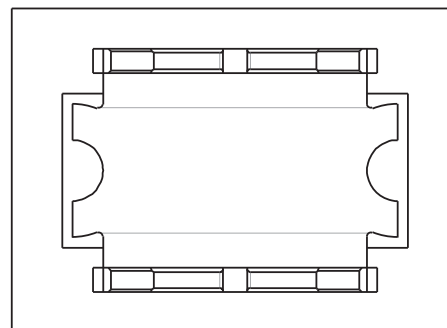

**ORIENTATION OF CONTACT
ON PAD**

NOTES:

1. FOR FULL PRODUCT SPECIFICATION REFER TO AVX SPEC 201-01-208 AND 201-01-209
2. DIMENSIONS SHOWN ARE REFERENCE DIMENSIONS.
3. ASSEMBLY TOOLING ON PAGE 4.

Single IDC Contact 12-18 AWG

9177-500

ASSEMBLY TOOLING

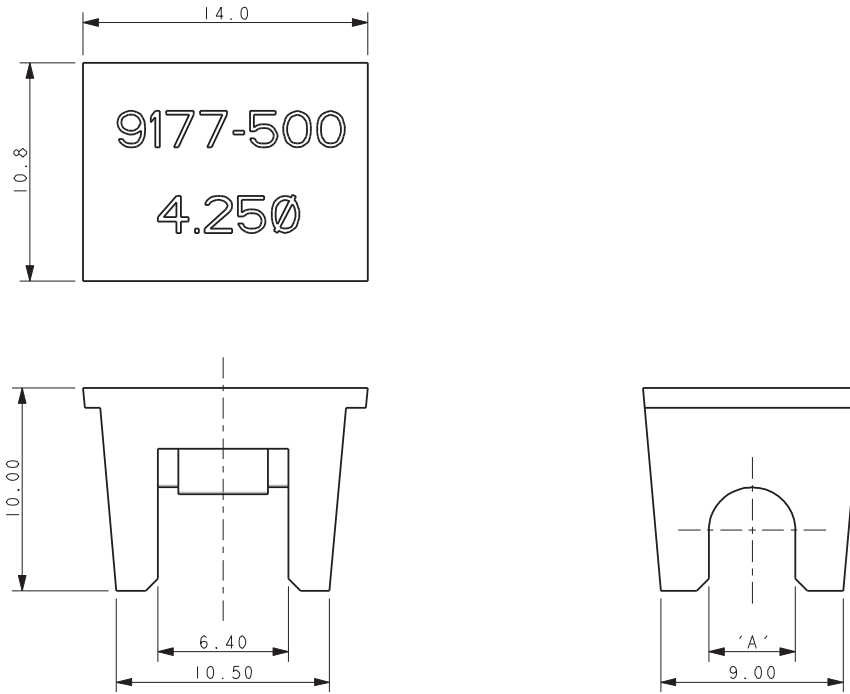

Wire Gauge	Max Insulation (Dimensions 'A')	Tool Number Metal Tool for High Volume	Tool Number Plastic Tool for Small to Medium Volume
12-18 AWG	ø 4.25	06-9177-7020-01-001	06-9177-7022-01-001
12-18 AWG	ø 3.50	06-9177-7020-02-001	06-9177-7022-02-001
12-18 AWG	ø 2.75	06-9177-7020-03-001	06-9177-7022-03-001

NOTES:

1. ASSEMBLY TOOLING FOR CONTACTS 70-9177-001-5XX-006 ONLY.
2. MINIMUM AREA OF PCB TO BE KEPT CLEAR OF COMPONENTS. TRACKS PERMISSIBLE.
3. MAXIMUM COMPONENT HEIGHT 9.0MM IN THIS AREA.
4. REFER TO TABLE FOR CORRECT TOOL/WIRE COMBINATION.
5. REFER TO APPLICATION NOTE 201-01-209 FOR FURTHER INFORMATION.
6. DIMENSIONS FOR TOOL ARE REFERENCE DIMENSIONS.

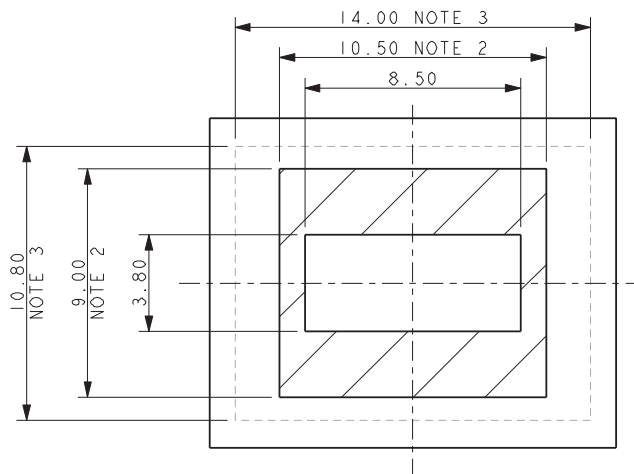

Данный компонент на территории Российской Федерации

Вы можете приобрести в компании MosChip.

Для оперативного оформления запроса Вам необходимо перейти по данной ссылке:

<http://moschip.ru/get-element>

Вы можете разместить у нас заказ для любого Вашего проекта, будь то серийное производство или разработка единичного прибора.

В нашем ассортименте представлены ведущие мировые производители активных и пассивных электронных компонентов.

Нашей специализацией является поставка электронной компонентной базы двойного назначения, продукции таких производителей как XILINX, Intel (ex.ALTERA), Vicor, Microchip, Texas Instruments, Analog Devices, Mini-Circuits, Amphenol, Glenair.

Сотрудничество с глобальными дистрибьюторами электронных компонентов, предоставляет возможность заказывать и получать с международных складов практически любой перечень компонентов в оптимальные для Вас сроки.

На всех этапах разработки и производства наши партнеры могут получить квалифицированную поддержку опытных инженеров.

Система менеджмента качества компании отвечает требованиям в соответствии с ГОСТ Р ИСО 9001, ГОСТ РВ 0015-002 и ЭС РД 009

Офис по работе с юридическими лицами:

105318, г.Москва, ул.Щербаковская д.3, офис 1107, 1118, ДЦ «Щербаковский»

Телефон: +7 495 668-12-70 (многоканальный)

Факс: +7 495 668-12-70 (доб.304)

E-mail: info@moschip.ru

Skype отдела продаж:

moschip.ru

moschip.ru_4

moschip.ru_6

moschip.ru_9