

## USB 2380, PCI Express to USB 2.0 Peripheral Controller

### Features

- **USB 2.0 Client Interface**
  - Compliant to the USB 2.0 Specification
  - 1 upstream port
  - Support Hi-Speed, Full-Speed modes
  - Four Descriptor-based DMA channels for automatic data transfers
  - Support USB Duet® Technology
  - Support for Bulk, Isochronous, and Interrupt Endpoints
  - USB Power Management
    - USB 2.0 link power management states: L0, L1, L2
- **PCI Express Interface**
  - PCI Express Gen 1 (2.5Gbps)
  - Electrical Compliance to PCI Express Base Specification r2.0
  - One x1 upstream port
  - PCI Express Power Management
    - All link power management states: L0, L0s, L1, L2/L3 Ready, and L3
    - Device states: D0 and D3(hot & cold)
    - Vaux, Wake#, Beacon support
  - 256 byte maximum payload size
  - ExpressCard 2.0 compliance
- **General**
  - Four GPIO pins for maximum design flexibility
  - 10mm x 10mm 88-pin QFN package with 0.4 mm pitch
  - Low power 90nm technology
  - Industrial Temp support
  - Lead-free package

The USB 2380 is a PCI Express Gen 1 (2.5Gbps) to USB 2.0 Hi-Speed Peripheral Controller. It features one PCI Express Gen 1 x1 port and one USB 2.0-compliant client port.



### High Performance and Flexibility

The USB 2380 provides 480Mbps bandwidth between the PCI Express Gen 1 bus and the USB 2.0 Hi-Speed bus. The controller can easily add a USB 2.0 client port to an existing PCI Express system. The USB 2380's standard PCI Express interface provides a x1 upstream port to connect directly to any PCI Express downstream port for maximum performance of the product.

### Abundant Software

As the successor of the gold standard NET 2280, PCI to USB 2.0 Peripheral Controller, the USB 2380 can be used with existing NET 2280/2282 software with no change. Driver stacks are already available in common OS's such as Windows (XP, Vista, 7 and CE), Linux, and VxWorks. The USB Duet software will provide the fastest PC interconnect at 480Mbps of transfer speed with just a simple USB cable.

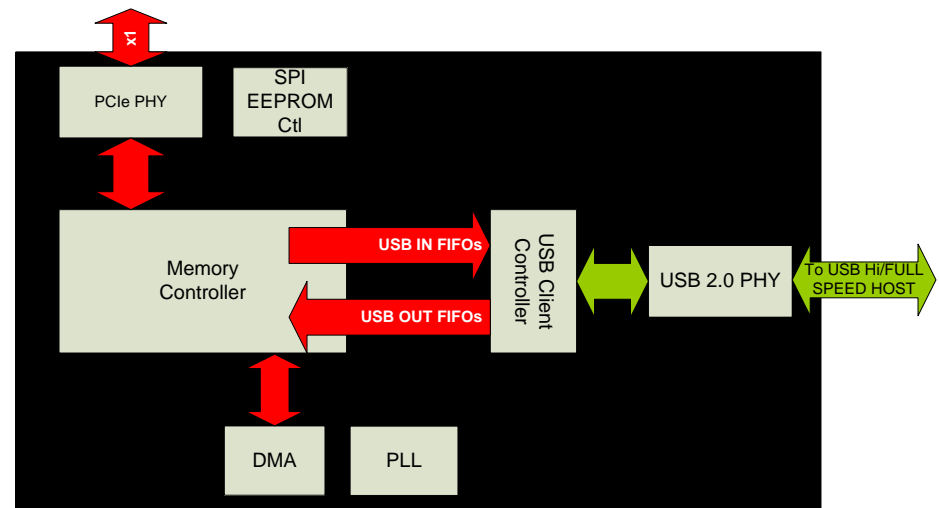

Figure 1: USB 2380 Block Diagram

### Applications

Target applications for the USB 2380 as a PCI Express endpoint include PCs, servers, set-top boxes (STBs), digital video recorders (DVRs), printers, and PCI Express embedded systems.

### Add a USB 2.0 Client Port to PCI Express-Based Systems

The USB 2380 can be used to easily add a USB 2.0 client port to any PCI Express based embedded system. As a PCI Express endpoint, the USB 2380's standard PCI Express interface connects directly to any PCI Express bus.

## USB 2380, PCI Express to USB 2.0 Peripheral Controller

Standard PCI Express registers allow the existing Root Complex to configure and send data to and from the USB 2380.

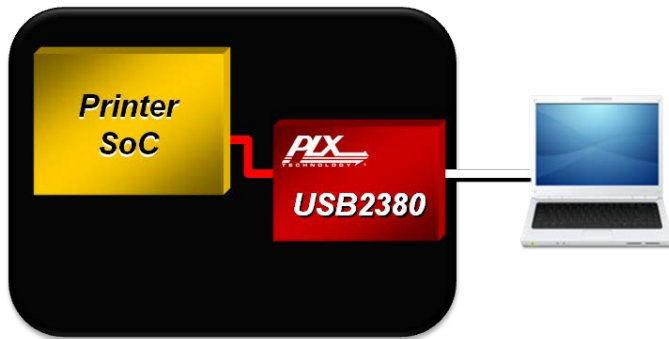

**Figure 2: Adding a USB 2.0 client port to a PCI Express based Printer with USB 2380**

Firmware is available to configure the USB 2380 to resemble a standard USB class device (like a printer or mass storage device) for which no USB host drivers will need to be written. For custom applications, firmware APIs are provided to abstract the USB transactions to reads and writes. This firmware is available for various operating systems including Windows (XP, Vista, 7 and CE), Linux, and VxWorks.

### USB Duet Technology for Mobile PCs

The USB 2380 can be used to easily add a USB 2.0 client port to a PCI Express based netbook architecture. The hardware design is simple by connecting the PCI Express signals to the PCI Express bus on the netbook chipset.

Adding a USB 2.0 client port to the netbook creates innovative and killer applications for users, such as optical disc drive sharing, instant file sharing, networking, and full HDD/partition recovery, all over a simple USB cable connection.

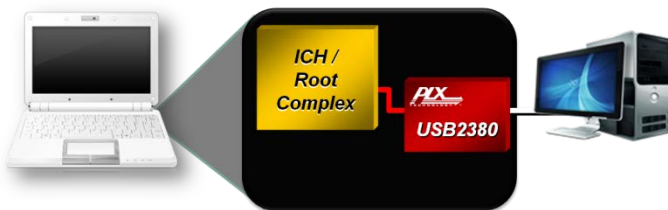

**Figure 2: Adding a USB 2.0 client port to a PCI Express based Netbook/Mobile PC with USB 2380**

Software is already complete with Windows 7 Logo certified and Linux drivers available for the USB Duet file-sharing and networking functions. PLX provides a turnkey hardware and software solution, which brings the netbook with USB Duet Technology quick to market. For more information on USB Duet Technology, visit [www.usbduet.com](http://www.usbduet.com).

### Development Tools

PLX offers hardware and software tools to enable rapid customer design activity. These tools consist of a hardware module (USB2380EVK), hardware documentation (available at [www.plxtech.com](http://www.plxtech.com)), and a Software Development Kit.

The USB2380EVK is a x1 PCI Express adapter board that easily plugs into any standard PCI Express slot.

Both USB host and peripheral-side software is included with the USB2380EVK. The host-side software consists of USB drivers and test applications. The peripheral-side firmware is used to configure the USB 2380 to resemble a standard USB class device (like a printer or mass storage device) for which no USB host drivers will need to be written. For custom applications, firmware APIs are provided to abstract the USB transactions to reads and writes. While this software is available for various operating systems, it is written in standard C with portability in mind.

### Product Ordering Information

Part Number	Description
USB2380-AB25NI G	One x1-port PCI Express Gen 1.0 to USB 2.0 Hi-Speed Peripheral Controller (10x10mm <sup>2</sup> )
USB2380-AB EVK	USB 2380 Rapid Development Kit

Visit [www.plxtech.com](http://www.plxtech.com) for more information.

## Данный компонент на территории Российской Федерации

### Вы можете приобрести в компании MosChip.

Для оперативного оформления запроса Вам необходимо перейти по данной ссылке:

<http://moschip.ru/get-element>

Вы можете разместить у нас заказ для любого Вашего проекта, будь то серийное производство или разработка единичного прибора.

В нашем ассортименте представлены ведущие мировые производители активных и пассивных электронных компонентов.

Нашей специализацией является поставка электронной компонентной базы двойного назначения, продукции таких производителей как XILINX, Intel (ex.ALTERA), Vicor, Microchip, Texas Instruments, Analog Devices, Mini-Circuits, Amphenol, Glenair.

Сотрудничество с глобальными дистрибьюторами электронных компонентов, предоставляет возможность заказывать и получать с международных складов практически любой перечень компонентов в оптимальные для Вас сроки.

На всех этапах разработки и производства наши партнеры могут получить квалифицированную поддержку опытных инженеров.

Система менеджмента качества компании отвечает требованиям в соответствии с ГОСТ Р ИСО 9001, ГОСТ РВ 0015-002 и ЭС РД 009

### Офис по работе с юридическими лицами:

105318, г.Москва, ул.Щербаковская д.3, офис 1107, 1118, ДЦ «Щербаковский»

Телефон: +7 495 668-12-70 (многоканальный)

Факс: +7 495 668-12-70 (доб.304)

E-mail: [info@moschip.ru](mailto:info@moschip.ru)

Skype отдела продаж:

moschip.ru

moschip.ru\_4

moschip.ru\_6

moschip.ru\_9