

RYC91xx

PWM Power Supply Controller

Document: SCD 25391
Status: Preliminary
Rev. A April 16, 2003

GENERAL DESCRIPTION

The RYC91XX is a digital PWM controller designed for small power, universal line voltage applications.

The RYC91xx series of PWM controllers allows the designer to implement source switched architecture to control the HV MOSFET or emitter switched architecture to control a BJT. Using this technique, the pin count, as well as the number of external components are minimized.

The RYC91XX utilizes three-terminal operation by combining the feedback pin with the bias supply pin. Current sensing is incorporated within the device and is made possible through the unique source/emitter switching architecture.

The RYC91xx contains a startup current source, PWM generator, junction temperature monitor, current sensing and its comparator, and a high current open-drain output stage capable of carrying the entire primary side peak and RMS current for up to 5W applications.

FEATURES

- Unique emitter drive capability to switch BJT's
- Low operating current allows for low power consumption, green supply designs
- 3 terminal design in a TO-92 package
- Auto shut down and restart
- Cycle-by-cycle current limit
- Pulse skip mode operation
- OT protection
- UV protection
- Optional frequency dither to reduce Electromagnetic Interference (EMI)

APPLICATIONS

- Cell phone battery chargers
- PDA power supplies
- Digital Cameras
- Set-top cable converter boxes
- Digital video keep-alive supplies
- Low Quiescent current (Green) power supplies for appliances and White Goods
- Universal off-line power supplies (up to 5W)

TYPICAL APPLICATION SCHEMATICS

Implemented with a BJT

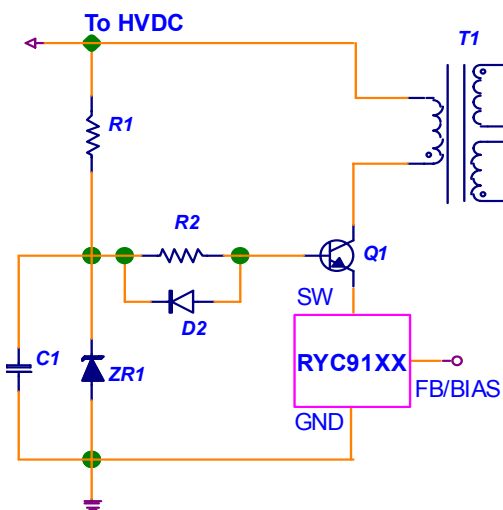

Implemented with a MOSFET

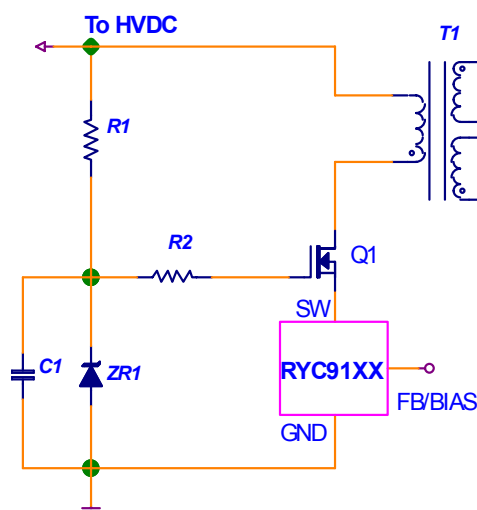

RYC91xx

PWM Power Supply Controller

Document: SCD 25391
Status: Preliminary
Rev. A April 16, 2003

ORDERING INFORMATION

Part Description	Voltage mode vs. Current mode	Frequency (kHz)	Current Limit (mA, typ)	Package Type
RYC9114-1T	Current	65	400	TO-92
RYC9114-2T	Voltage	65	400	TO-92
RYC9124-1T	Current	130	400	TO-92
RYC9124-2T	Voltage	130	400	TO-92

Note: Other options are available, please contact factory.

PIN CONFIGURATION

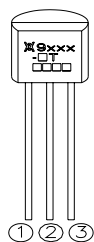

DEVICE MARKING

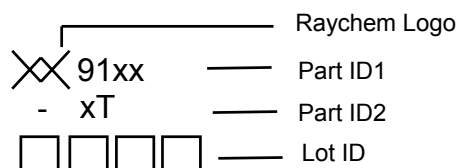

PIN DESCRIPTION

Pin Number	Pin Name	Pin Function
1	FB/BIAS	Input for both IC feedback and bias supply, acceptable range: 3.6 to 5.8V
2	GND	Control ground and supply return
3	SW	Switch output

BLOCK DIAGRAM

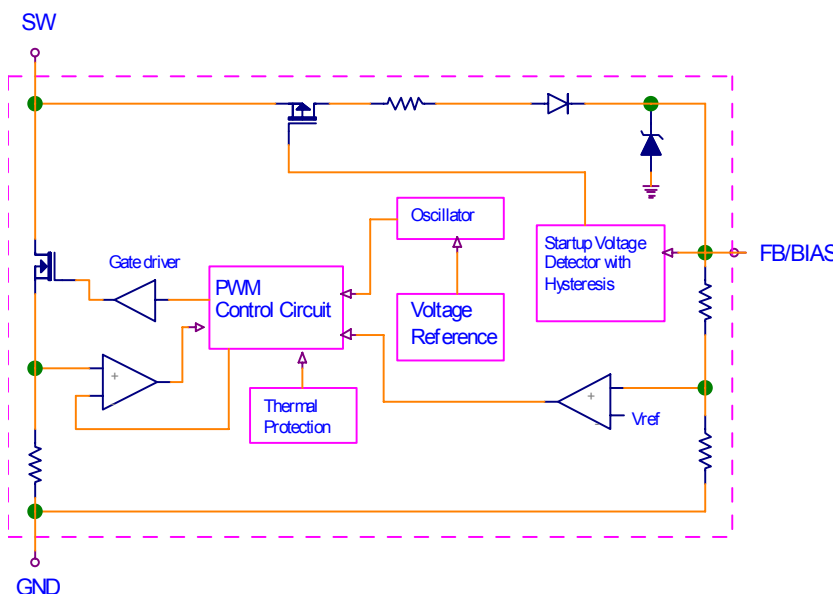

RYC91xx

PWM Power Supply Controller

Document: SCD 25391
 Status: Preliminary
 Rev. A April 16, 2003

ABSOLUTE MAXIMUM RATINGS (Notes 1,2)

Parameter	Symbol	Value	Units
Max Switch Voltage	V_{SW}	-0.3 to +25	V
Max Bias Supply Voltage	$V_{FB/BIAS}$	-0.3 to +6.7	V
Storage Temperature	T_S	-65 to +165	°C
Operating Junction Temperature	T_J	-20 to 125	°C
Max Power Dissipation	P_D	0.6	W
Junction To Ambient Thermal resistance	$R_{\theta,J-A}$	200	°C/W

Note 1. Operation beyond absolute maximum rating or improper use may result in permanent damage to the device. Exposure to absolute maximum rating conditions for extended periods or to conditions beyond absolute maximum rating conditions may adversely affect device reliability. Functional operation under absolute maximum rating conditions is not implied.

Note 2. Devices are ESD sensitive. Handling precautions recommended.

ELECTRICAL CHARACTERISTICS ($T_A = 25^\circ\text{C}$ unless noted)

Parameters	Conditions	Min	Typ	Max	Units
FB/BIAS Clamp voltage	$I_{IN} = 5\text{mA}$	5.9	6.3	6.7	V
FB/BIAS Start Threshold		5.4	5.8	6.2	V
FB/BIAS UV Threshold	After turn on	3.4	3.6	4.0	V
Supply Current	No switching	0.2	0.4	1	mA
	Full load switching, $F_{SW} = 130\text{kHz}$	0.5	0.9	1.5	mA
OFF State Leakage Current	$V_{SW} = 10\text{V}$	0.2	2.2	30	μA
Switch to Bias Resistor	During startup, Note 3		2.5		$\text{k}\Omega$
Rise Time	1000 pF capacitor load with 15 Ω pull up resistor	15	30	70	ns
Fall Time	1000 pF capacitor load with 15 Ω pull up resistor	10	20	50	ns
Output Drive FET On Resistance	25 °C		1.9		Ω
	125 °C, Note 3		2.9		Ω
Thermal Shutdown Temperature	Note 3		145		°C
Thermal Shutdown Hysteresis	Note 3		14		°C
Output Current Limit	$di/dt = 100\text{mA}/\mu\text{s}$		400		mA
Output Current Limit Delay	$di/dt = 165\text{mA}/\mu\text{s}$		150		ns
Output Current Limit Blanking Time		150	250	380	ns
Output Frequency	RYC9114		65		kHz
	RYC9124		125		kHz
Output Frequency Dither			0		kHz
Minimum Duty Cycle			3.9	6	%
Maximum Duty Cycle		65	74	80	%
PWM Gain		0.06	0.09	0.15	%/mV
Input Dynamic Impedance		4.3	5.7	7.2	$\text{k}\Omega$

Note 3. Validated by design, not production tested.

RYC91xx

PWM Power Supply Controller

Document: SCD 25391
Status: Preliminary
Rev. A April 16, 2003

TYPICAL CHARACTERISTICS

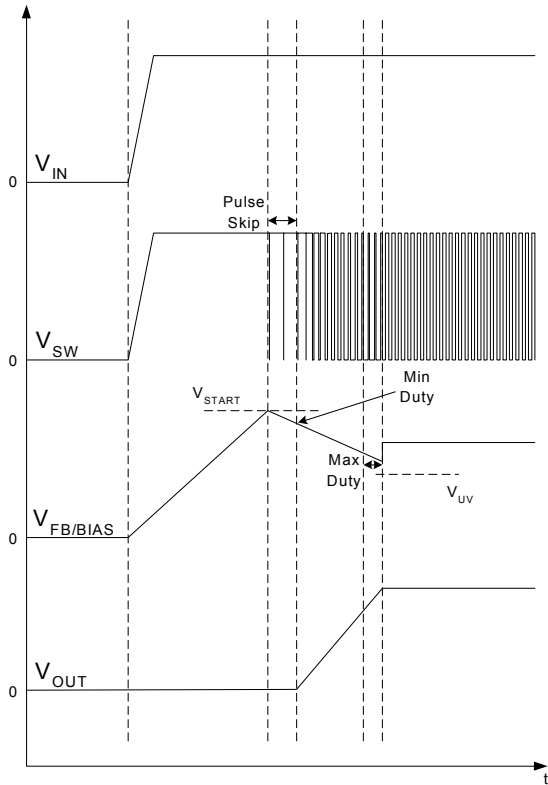

Figure 1. Power-up waveforms

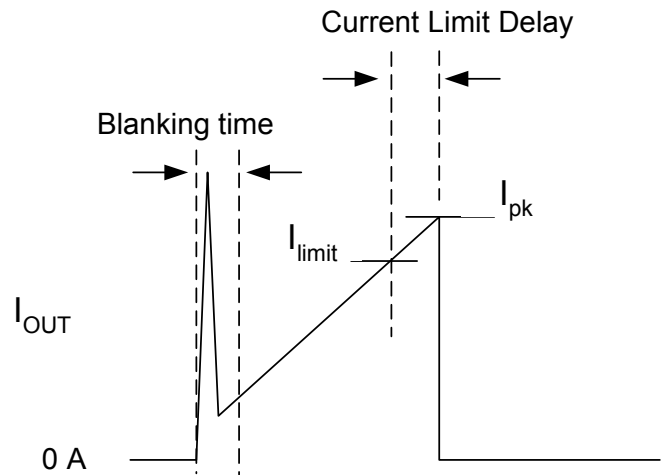

Figure 2. Graphical explanation of Current Limit terminology

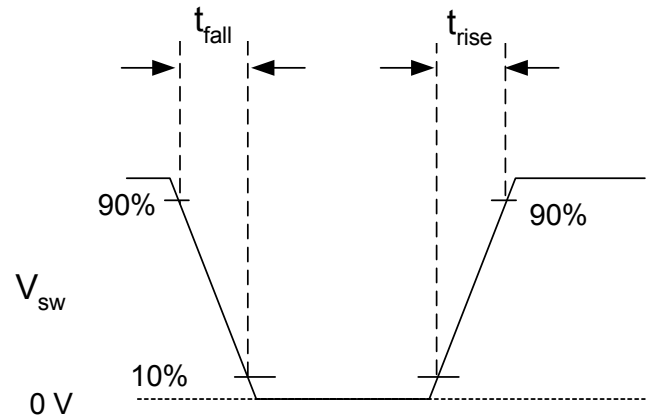

Figure 3. Rise and fall time

RYC91xx

PWM Power Supply Controller

Document: SCD 25391
Status: Preliminary
Rev. A April 16, 2003

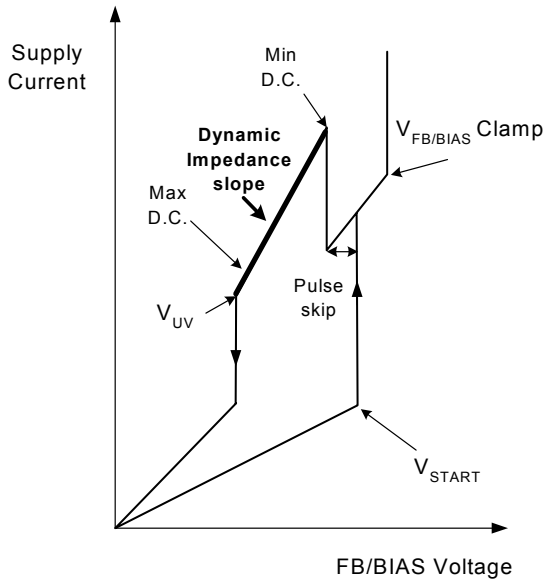

Figure 4. Supply Current vs. FB/BIAS Voltage

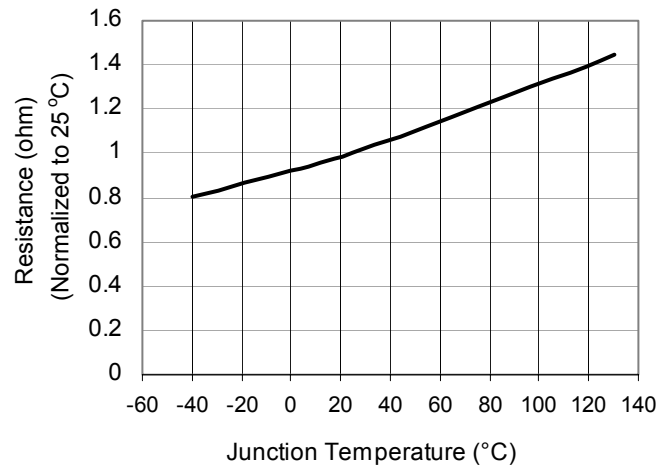

Figure 5. R_{ON} vs. Temperature

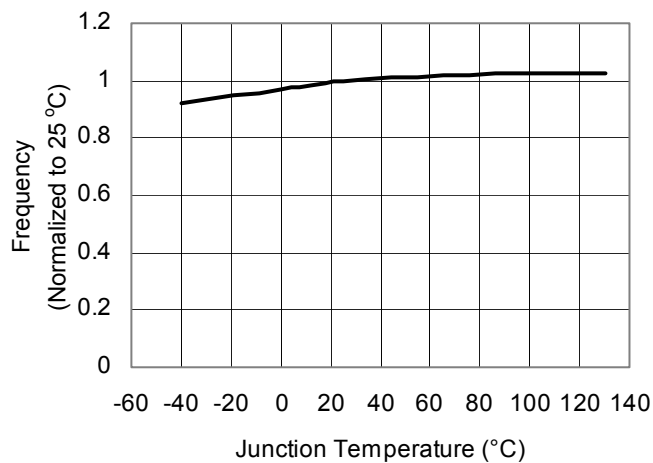

Figure 6. Frequency vs. Temperature

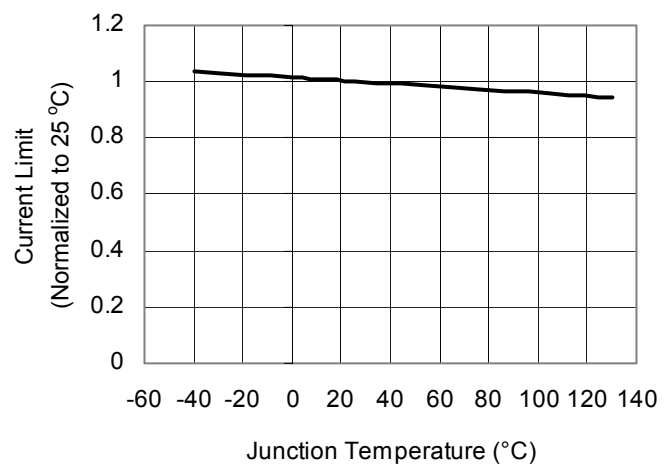

Figure 7. Current Limit vs. Temperature

RYC91xx

PWM Power Supply Controller

Document: SCD 25391
Status: Preliminary
Rev. A April 16, 2003

FUNCTIONAL DESCRIPTION

The three-terminal RYC91XX series PWM controller includes a switch pin (SW), a feedback and bias pin (FB/BIAS) and ground pin (GND). The SW pin is an open-drain output with a current sensing circuit in its output path. The open-drain MOSFET is designed to carry the entire primary side peak and RMS currents for up to 5W line-voltage fed power supplies. The startup current source is also supplied through the switch terminal. The FB/BIAS pin accomplishes two functions: 1) Voltage feedback function. The output voltage is normally fed back to this pin through an op-to isolator. And 2) Bias supply function. The IC's bias power is received at this pin. These two functions are internally decoupled for independent performance.

The initial bias power is supplied through the P-Ch MOSFET, the resistor and the blocking diode as shown in the functional block diagram. As the FB/BIAS pin voltage reaches a startup threshold value, the PMOS is turned off and the IC starts to drive the HV transistor in a PWM manner. The initial IC bias voltage is supplied by the energy of the external capacitor on the FB/BIAS terminal until feedback energy is received from the auxiliary winding of the transformer.

APPLICATION INFORMATION

4W Constant Voltage Constant Current Cell-Phone Charger

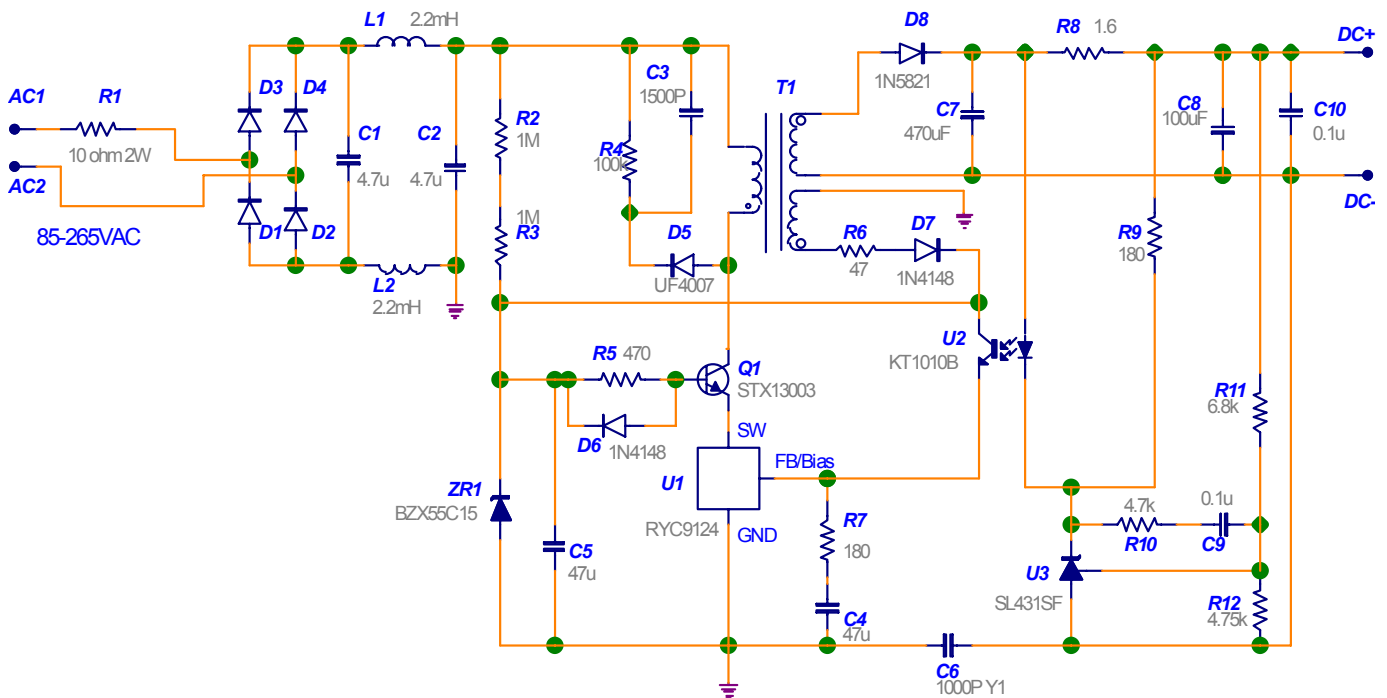

A typical application schematic is shown above, using the RYC91XX with a BJT as the high voltage transistor. The power supply operates over a universal input range (85–265 VAC) and delivers 6V, 700mA current which is adequate to charge most single-cell Lithium-ion batteries.

RYC91xx

PWM Power Supply Controller

Document: SCD 25391
Status: Preliminary
Rev. A April 16, 2003

The inductors L1 and L2, along with the capacitors C1 and C2, provide both common mode and differential mode attenuations for EMI. This filter along with the Y1 Capacitor C6 and the BJT slew control during switching transitions, ensures the power supply to meet the worldwide EMI standards with a 130 kHz switching frequency.

The high voltage BJT is driven with an emitter switched manner, hence the turn-off storage time is drastically reduced. Resistor R5 limits the base current during turn-on and during forward conduction. Zener diode ZR1 clamps the BJT bias as well as the auxiliary winding output of the transformer to 15V. During startup, a small base and collector current flow into the internal current source of RYC91XX and charge the capacitor C4. As the voltage at the FB/BIAS pin reaches the start threshold level (5.8V), the controller wakes up, performing PWM function and the internal current source is disconnected at the same time. The energy stored in C4 supplies the IC bias power until adequate energy has been transferred to the output and the auxiliary winding.

The error amplifier circuit of U3 provides a constant voltage output. The constant current output is accomplished by the voltage drop across the current sensing resistor R8. As the output current increases this voltage reaches the forward bias voltage of the LED of the op-to isolator, the output control is thus switched to a constant current mode.

Please refer to the appropriate application notes for more details of the application.

PACKAGE INFORMATION

Mechanical Dimensions

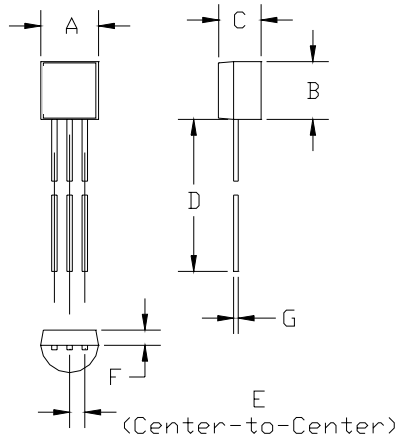

DIMENSION	MIN mm	MAX mm	MIN inch	MAX inch
A	4.45	5.08	0.175	0.2
B	4.45	5.08	0.175	0.2
C	3.45	3.68	0.135	0.145
D	12.7		0.5	
E	1.26	1.28	0.0498	0.0502
F	1.14	1.40	0.045	0.055
G	0.13	0.51	0.005	0.02

TO-92 PACKAGE NOTES:

1. Dimensions and tolerance per ANSI Y14.5M-1982.
2. Controlling dimensions: Millimeters
3. Dimensions do not include mold flash. Mold flash shall not exceed 0.15mm [0.006] per side.
4. Interlead flash shall not exceed 0.25 mm [0.010].

RYC91xx

PWM Power Supply Controller

Information furnished is believed to be accurate and reliable. However, users should independently evaluate the suitability of each product for their applications. Tyco Electronics Corporation assumes no responsibility for the use of its product or for any infringement of patents or other rights of third parties resulting from the use of its product. No license is granted by implication or otherwise under any patent or proprietary right of Tyco Electronics except the right to use such product for the purpose for which it is sold. Tyco Electronics reserves the right to change or update, without notice, any information contained in this publication; to change, without notice, the design, construction, processing, or specification of any product; and to discontinue or limit production or distribution of any product. This publication supersedes and replaces all information previously supplied. Without express written consent by an officer of Tyco Electronics, Tyco Electronics does not authorize the use of any its products as components in nuclear facility applications, aerospace, or in critical life support devices or systems. Tyco Electronics' only obligations are those in the Tyco Electronics Standard Terms and Conditions of Sale and in no case will Tyco Electronics be liable for any incidental, indirect, or consequential damages arising from the sale, resale, use, or misuse of its products.

Raychem is a trademark of Tyco Electronics Corporation

© 2003 Tyco Electronics Corporation

Mouser Electronics

Authorized Distributor

Click to View Pricing, Inventory, Delivery & Lifecycle Information:

[Littelfuse:](#)

[RYC9114-1T](#) [RYC9114-2T](#) [RYC9124-2T](#)

Данный компонент на территории Российской Федерации

Вы можете приобрести в компании MosChip.

Для оперативного оформления запроса Вам необходимо перейти по данной ссылке:

<http://moschip.ru/get-element>

Вы можете разместить у нас заказ для любого Вашего проекта, будь то серийное производство или разработка единичного прибора.

В нашем ассортименте представлены ведущие мировые производители активных и пассивных электронных компонентов.

Нашей специализацией является поставка электронной компонентной базы двойного назначения, продукции таких производителей как XILINX, Intel (ex.ALTERA), Vicor, Microchip, Texas Instruments, Analog Devices, Mini-Circuits, Amphenol, Glenair.

Сотрудничество с глобальными дистрибьюторами электронных компонентов, предоставляет возможность заказывать и получать с международных складов практически любой перечень компонентов в оптимальные для Вас сроки.

На всех этапах разработки и производства наши партнеры могут получить квалифицированную поддержку опытных инженеров.

Система менеджмента качества компании отвечает требованиям в соответствии с ГОСТ Р ИСО 9001, ГОСТ РВ 0015-002 и ЭС РД 009

Офис по работе с юридическими лицами:

105318, г.Москва, ул.Щербаковская д.3, офис 1107, 1118, ДЦ «Щербаковский»

Телефон: +7 495 668-12-70 (многоканальный)

Факс: +7 495 668-12-70 (доб.304)

E-mail: info@moschip.ru

Skype отдела продаж:

moschip.ru

moschip.ru_4

moschip.ru_6

moschip.ru_9