

3M™ Bumpon™ Protective Products

Resilient Rollstock

SJ5200 • SJ5800 • SJ5900 • SJ6000 • SJ6200 Series

Product Description

3M™ Bumpon™ Resilient Rollstock Products are opaque, colored polyurethane materials produced with aggressive pressure-sensitive adhesives.

3M™ Bumpon™ Resilient Rollstock Product	Thickness		Polyurethane Hardness, Shore M	Polyurethane Surface Finish	Adhesive Type
	Inches	mm			
SJ5216	1/16	1.6	36 (soft foam)	matte	R-25 (synthetic rubber)
SJ5208	1/8	3.2	29 (soft foam)		
SJ5832	1/32	0.8	72	matte	R-30 (natural rubber)
SJ5801	3/64	1.0	72		
SJ5816	1/16	1.6	72		
SJ5808	1/8	3.2	72		
SJ5916	1/16	1.6	40 (medium foam)	matte	A-20 (acrylic)
SJ5908	1/8	3.2	36 (medium foam)		
SJ5904	1/4	6.4	36 (medium foam)		
SJ6032	1/32	0.8	72	matte	A-20 (acrylic)
SJ6016	1/16	1.6	72		
SJ6008	1/8	3.2	72		
SJ6005	1/5	5.0	72		
SJ6232	1/32	0.8	72	matte	R-25 (synthetic rubber)
SJ6216	1/16	1.6	72		
SJ6208	1/8	3.2	72		

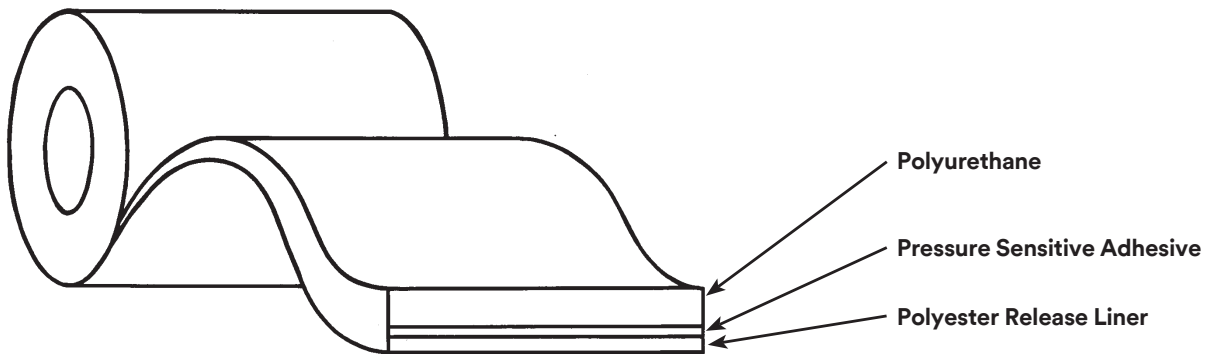

3M™ Bumpon™ Protective Products

Resilient Rollstock SJ5200 • SJ5800 • SJ5900 • SJ6000 • SJ6200 Series

Features

- Can be die cut to a variety of shapes and sizes.
- Excellent skid-resistance, high coefficient of friction.
- Excellent resistance to marring or staining.*
- Long aging resiliency – will not crack or harden.*
- Excellent cushioning properties.
- Excellent abrasion resistance.
- Vibration and shock dampening.
- Easy application – pressure-sensitive backing.

*Resulting from a urethane composition.

Application Ideas

- Die cut into circles or squares for use as skid-resistant feet on hand held or desktop computers, calculators, electric housewares, electronic equipment, desk top items and medical devices.
- Die cut for gasket application.
- Skid-resistant surface on floor.
- Cushions or spacers within electronic devices.
- Selective masking for sandblast operation.
- Spacer or stop to prevent surface damage.
- Anti-rattle spacer to fill gaps, dampen noise and reduce vibration.
- Door kick pads.
- Corner protection strips.
- Roll covering for textile industry and other web feed machinery.
- Die cut cushioning stop for cabinetry (3M™ Bumpon™ Resilient Rollstock SJ5200 and SJ5900 Foam).

3M™ Bumpon™ Protective Products

Resilient Rollstock SJ5200 • SJ5800 • SJ5900 • SJ6000 • SJ6200 Series

Product Construction

3M™ Bumpon™ Resilient Rollstock Series										
	SJ5200	SJ5800		SJ5900		SJ6000		SJ6200		
Elastomer	Polyurethane (foam)		Polyurethane (solid)		Polyurethane (foam)		Polyurethane (solid)		Polyurethane (solid)	
Elastomer Finish	matte		matte		matte		matte		matte	
Release Liner	4 mil, silicone coated, translucent polyester (PET), with printed 3M logo		4 mil, silicone coated, translucent polyester (PET), with printed 3M logo		4 mil, silicone coated, translucent polyester (PET), with printed 3M logo		4 mil, silicone coated, translucent polyester (PET), with printed 3M logo		4 mil, silicone coated, translucent polyester (PET), with printed 3M logo	
Adhesive	R-25 (synthetic rubber)		R-30 (natural rubber)		A-20 (acrylic)		A-20 (acrylic)		R-25 (synthetic rubber)	

3M™ Bumpon™ Resilient Rollstock Product

	SJ5216	SJ5208	SJ5832	SJ5801	SJ5816	SJ5808	SJ5916	SJ5908	SJ5904	SJ6032	SJ6016	SJ6008	SJ6005	SJ6232	SJ6216	SJ6208
Color	Light Brown	Light Brown	Black Brown	Black	Black Brown	Black Brown	Black	Black	Black	Black Brown	Black Brown	Black Brown	White Black	Black	Black	Black
Thickness* in.	1/16	1/8	1/32	3/64	1/16	1/8	1/16	1/8	1/4	1/32	1/16	1/8	1/5	1/32	1/16	1/8
in. (mm)	0.062 (1.6)	0.125 (3.2)	0.031 (0.8)	0.039 (1.0)	0.062 (1.6)	0.125 (3.2)	0.062 (1.6)	0.125 (3.2)	0.250 (6.4)	0.031 (0.8)	0.062 (1.6)	0.125 (3.2)	0.20 (5.0)	0.031 (0.8)	0.062 (1.6)	0.125 (3.2)
Thickness ± in.	0.010	0.015	0.005	0.006	0.007	0.010	0.010	0.015	0.020	0.005	0.007	0.010	0.012	0.05	0.007	0.010
Tolerance ± (mm)	(0.25)	(0.38)	(0.13)	(0.15)	(0.18)	(0.25)	(0.25)	(0.38)	(0.50)	(0.13)	(0.18)	(0.25)	(0.31)	(0.13)	(0.18)	(0.25)
Roll Length yd.	36	36	72	72	36	36	36	36	18	72	36	36	24	72	36	36
Roll Width**																
Standard in.	4.5	4.5	4.5	4.5	4.5	4.5	4.5	4.5	4.5	4.5	4.5	4.5	4.5	4.5	4.5	4.5
(mm)	(114.3)	(114.3)	(114.3)	(114.3)	(114.3)	(114.3)	(114.3)	(114.3)	(114.3)	(114.3)	(114.3)	(114.3)	(114.3)	(114.3)	(114.3)	(114.3)
Minimum in.	0.5	0.5	0.5	-	0.5	1	0.5	0.5	1	0.5	0.5	1	-	0.5	0.5	1
(mm)	(12.7)	(12.7)	(12.7)	-	(12.7)	(25.4)	(12.7)	(12.7)	(25.4)	(12.7)	(12.7)	(25.4)	-	(12.7)	(12.7)	(25.4)
Maximum in.	9	9	9	9	9	9	9	9	9	9	9	9	9	9	9	9
(mm)	(228.6)	(228.6)	(228.6)	(228.6)	(228.6)	(228.6)	(228.6)	(228.6)	(228.6)	(228.6)	(228.6)	(228.6)	(228.6)	(228.6)	(228.6)	(228.6)
Slitting ± in.	1/32		1/32				1/32			1/32			1/32			
Tolerance ± in.	0.031		0.031				0.031			0.031			0.031			
± (mm)	(0.8)		(0.8)				(0.8)			(0.8)			(0.8)			

*Tested in accordance with ASTM D-3767 method, procedure A (3.2 psi) measured without liner.

**Non-standard sizes may be subject to minimum order requirements.

Custom Rollstock Products

Custom Thickness: 3M can customize thickness to your specifications.

Note: The capability range for 3M™ Bumpon™ Resilient Rollstock Series SJ5800, SJ6000, and SJ6200 is 1/32 in. (0.031) minimum and 1/4 in. (0.250) maximum.

The capability range for 3M™ Bumpon™ Resilient Rollstock Series SJ5900 is 1/16 in. (0.062) minimum and 5/16 in. (0.312) maximum.

Custom Color: 3M can match most colors to your specifications.

Note: Special products require a qualifying minimum order quantity, and one-time color matching charge. For more information please contact your local 3M sales rep or distributor.

3M™ Bumpon™ Protective Products

Resilient Rollstock SJ5200 • SJ5800 • SJ5900 • SJ6000 • SJ6200 Series

Typical Physical Properties and Performance Characteristics

Note: The following technical information and data should be considered representative or typical only and should not be used for specification purposes.

Property	Test Method***	3M™ Bumpon™ Resilient Rollstock Series				
		SJ5200	SJ5800	SJ5900	SJ6000	SJ6200
Hardness, Shore M	ASTM-D-2240	36 (SJ5216) 29 (SJ5208)	72	40 (SJ5916) 36 (SJ5908, SJ5904)	72	72
Approximate Density, lb/ft ³ (g/cm ³)		40 (0.64)	80 (1.3)	40 (0.64)	80 (1.3)	80 (1.3)
Kinetic Coefficient of Friction*	ASTM-D-1894					
	Stainless Steel	*	>1	>1	>1	>1
	Glass	*	>1	>1	>1	>1
	Formica® laminate	*	0.9 - 1.4	0.8 - 1.4	0.9 - 1.4	0.9 - 1.4
Wood	*	0.9 - 1.4	0.9 - 1.4	0.8 - 1.4	0.9 - 1.4	0.9 - 1.4
<p>* Two important laws of friction applicable to 3M™ Bumpon™ Resilient Rollstock are: (1) Friction is independent of the area of contact between solids. (2) Friction is proportional to the load between solid surfaces. Thus, if the load (weight) is doubled, the force required to cause surface sliding is also doubled. This is expressed mathematically as follows:</p> <p style="text-align: center;">Sliding force = (kinetic coefficient of friction) x (weight)</p>						
Abrasion Resistance Taber H 18, 1 kg, g/1000 cycles	ASTM-C-501	*	1.7 - 1.9	1.8 - 2.0	1.7 - 1.9	1.7 - 1.9
Tensile, lb/in ² (kPa)	ASTM-D-412, Die A	*	600 (4140)	120 (830)	600 (4140)	600 (4140)
Elongation, %	ASTM-D-412, Die A	*	100	100	100	100
Compression Set, %	ASTM-D-1056	8	–	12	–	–
	(50% deflection)	10	–	14	–	–
	ASTM-D-395	–	3	–	3	3
(25% deflection)	–	4	–	4	4	
Dielectric Strength, volts/mil	ASTM-D-1000	*	200	140	200	200
Flammability Listing	UL Classification	*	UL94HB	UL94HBF (except SJ5916)	UL94HB	UL94HB
Stain Resistance**	3M - 24 hrs. @ 158°F against white paint, 7 days exposed to UV		No staining observed			
Ozone and Oxygen Resistance**	3M - 30 days @ 50 ppm ozone		No visual deterioration			
Solvent and Fuel Resistance**	3M - 24 hr. immersion					
	5% Detergent in water		No apparent effect			
	25% Ammonia in water		No apparent effect			
	Bleach		No apparent effect			
	Hydrochloric Acid (1 normal solution)		No apparent effect			
	Diesel Fuel		No apparent effect			
	Auto Oil		No apparent effect			
	Isopropyl Alcohol		Slight effect (swelling)			
	Heptane		Slight effect (swelling)			
	Toluene (Toluol)		Considerable effect (swelling)			
	Lacquer Thinner		Considerable effect (swelling)			
Load Tolerance	The recommended maximum load which Bumpon Resilient Rollstock series SJ5800, SJ6000 and SJ6200 will support is 100 psi (690 kPa) at 70°F (21°C) to 120°F (49°C).					
Environmental Performance	Bumpon Resilient Rollstock is intended for interior applications where resilience and all other physical properties will remain unchanged. When exposed to UV light for extended periods, some discoloration may occur. Bumpon resilient rollstock may be used outdoors in a protected area with some discoloration and chalking possible.					

* = Not tested for Bumpon SJ5200 Series (soft foam)

** = Reference test for time periods specified only.

Results may vary for different product application conditions.

*** = When ASTM method is listed, data was collected in accordance with ASTM test method.

3M™ Bumpon™ Protective Products

Resilient Rollstock SJ5200 • SJ5800 • SJ5900 • SJ6000 • SJ6200 Series

Relative Adhesive Performance Characteristics

Note: The following technical information and data should be considered representative or typical only and should not be used for specification purposes.

3M™ Bumpon™ Resilient Rollstock			
	SJ5800 Series	SJ5900 Series SJ6000 Series	SJ5200 Series SJ6200 Series
Adhesive:	Natural Rubber R-30	Acrylic A-20	Synthetic Rubber R-25
Adhesion (Peel) Low Surface Energy: High Surface Energy:	Good Good	Poor Good	Excellent Excellent
Static Shear 75°F (25°C): 120°F (49°C): 158°F (70°C):	Excellent Fair Poor	Excellent Excellent Excellent	Excellent Good Fair
Initial Adhesion Low Surface Energy: High Surface Energy:	Good Good	Poor Fair	Excellent Excellent
Solvent Resistance:	Good	Excellent	Good
Age Life:	Good	Excellent	Good

Adhesive Performance

Note: The following technical information and data should be considered representative or typical only and should not be used for specification purposes.

The following table on peel adhesion provide representative performance characteristics of the adhesive systems used in the construction of 3M™ Bumpon™ Resilient Rollstock SJ5200, SJ5800, SJ5900, SJ6000, and SJ6200 series products.

90° Peel Adhesion

Peel Force, oz. per 1/2 inch

3M™ Bumpon™ Resilient Rollstock			
	SJ5800 Series	SJ5900 Series SJ6000 Series	SJ5200 Series SJ6200 Series
Substrate:	Natural Rubber R-30	Acrylic A-20	Synthetic Rubber R-25
Polypropylene	25	3	52
Polystyrene	25	11	55
ABS	25	25	55
Stainless Steel	22	25	55
Aluminum	22	25	55

3M Test Method TM-2011; 72 hour dwell, 1/2 inch wide samples pulled at 12 inches per minute. Testing completed using Bumpon Resilient Rollstock products SJ5816, SJ6016, and SJ6216.

3M™ Bumpon™ Protective Products

Resilient Rollstock SJ5200 • SJ5800 • SJ5900 • SJ6000 • SJ6200 Series

Adhesive Description

Natural Rubber (R-30) – Used in the construction of 3M™ Bumpon™ Resilient Rollstock SJ5800 Series products. This high tack adhesive system provides excellent initial adhesion and is designed for providing excellent adhesion to a wide variety of surfaces including many low surface energy surfaces such as polypropylene, polyethylene and powder coated paints. This adhesive system shows reduced shear properties at elevated temperatures.

Acrylic (A-20) – Used in construction of 3M™ Bumpon™ Resilient Rollstock SJ5900 and SJ6000 Series products. This high strength adhesive system provides excellent shear strength properties. The adhesive is designed for providing excellent adhesion to many high surface energy substrates such as metals, ABS, polycarbonate and acrylic. When adhesion is required on low surface energy substrates (ie, polypropylene, polyethylene, etc.) acrylic-based adhesives do not perform as well as rubber-based adhesives.

Synthetic Rubber (R-25) – Used in the construction of 3M™ Bumpon™ Resilient Rollstock SJ6200 Series products. This very high tack adhesive system provides excellent initial adhesion and is designed for providing excellent adhesion to a wide variety of surfaces including many low surface energy surfaces such as polypropylene, polyethylene and powder coated paints. Improved die-cutting performance with new polyester (PET) release liner. This adhesive system shows reduced shear properties at elevated temperatures.

Application Techniques

Application Temperature: 40°F (5°C) to 125°F (52°C)

Service Temperature: -30°F (-34°C) to 150°F (66°C)
225°F (107°C) intermittent exposure

To obtain maximum adhesion, surfaces should be flat, dry, and free of contaminants. Surface contact is essential to adhesive performance. To maximize contact on a substrate:

- Clean surfaces with low strength solvent such as isopropyl alcohol (rubbing alcohol) or heptane.
Note: Be sure to follow the solvent manufacturer's precautions and directions for use when using solvents.
- Apply firm pressure to help increase the cold flow and contact of the adhesive with the substrate.
- Allow time (dwell) to increase the surface contact and adhesion (see illustration below).

Adhesive Surface Contact

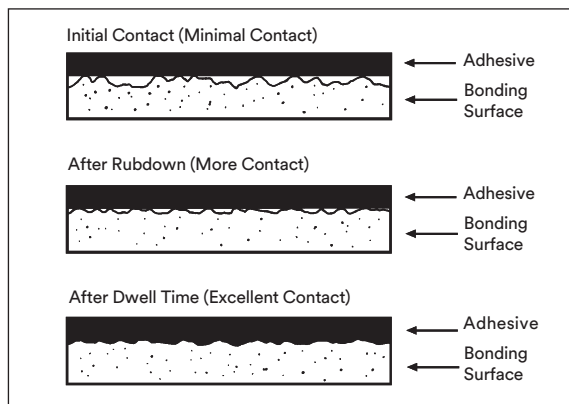

Rubber Adhesive vs. Acrylic Adhesive Bond Build-up

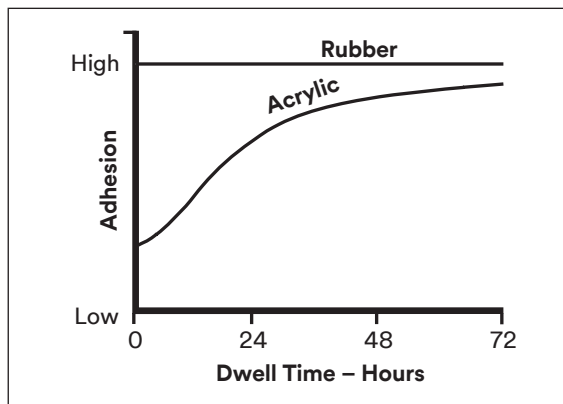

Note: Product selection is ultimately the responsibility of the user and should conduct their own tests under actual use and storage conditions to determine whether product is fit for a particular purpose and user's method of application.

3M™ Bumpon™ Protective Products

Resilient Rollstock SJ5200 • SJ5800 • SJ5900 • SJ6000 • SJ6200 Series

Die Cut Considerations

- Very important that knives be sharp.
- Although rotary die cutting can be used for thicker materials ($\geq 1/16$ inches), distortion in the die cut shape is possible using this die cutting method. Flat bed die cutting is recommended for thicker materials.
- The R-25 (synthetic rubber) adhesive system is very firm (tough). It can be more difficult to die cut versus the R-30 and A-20 adhesive systems. Also, the R-25 adhesive system is inherently stringy; as a result, if the adhesive is not thoroughly cut, the adhesive may have a tendency to string-out when the die cut parts are removed from the release liner quickly or by using a snapping motion. The adhesive string-out will not diminish the performance of the product.
- Some re-welding (tendency of the adhesive system to flow back together after die cutting) is possible with the R-25 adhesive system. Exposure to high temperature (greater than the recommended storage temperature of 60° to 80°F [16° to 27°C]) in combination with time and pressure will increase the tendency of re-welding.

Die Cut Examples

3M™ Bumpon™ Resilient Rollstock Products can be die cut to a variety of shapes and sizes. The following examples illustrate just a few of the possibilities.

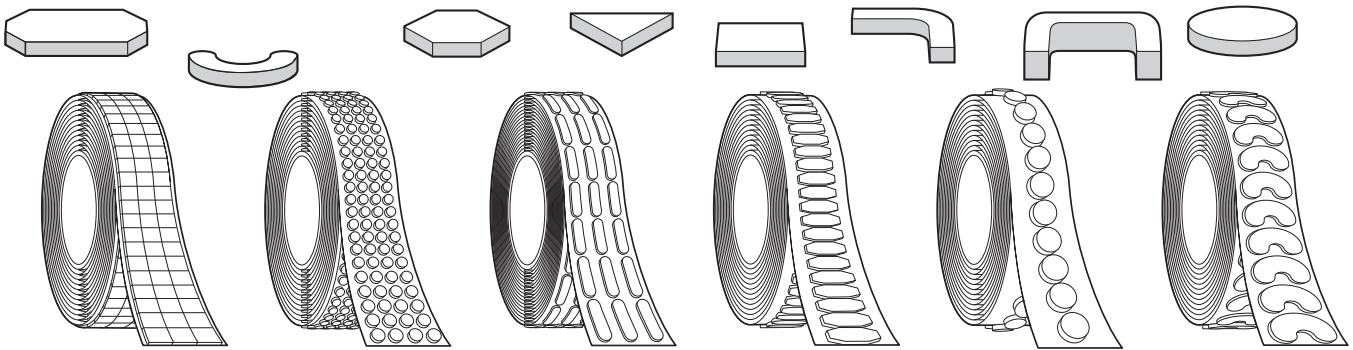

Storage and Shelf Life

The shelf life of 3M™ Bumpon™ Protective Products is 18 months from the date of manufacture when stored in the original packaging materials and stored at 16-27°C (60-80°F) and 50% relative humidity.

3M™ Bumpon™ Protective Products

Resilient Rollstock SJ5200 • SJ5800 • SJ5900 • SJ6000 • SJ6200 Series

Regulatory: For regulatory information about this product, contact your 3M representative.

Technical Information: The technical information, recommendations and other statements contained in this document are based upon tests or experience that 3M believes are reliable, but the accuracy or completeness of such information is not guaranteed.

Product Use: Many factors beyond 3M's control and uniquely within user's knowledge and control can affect the use and performance of a 3M product in a particular application. Given the variety of factors that can affect the use and performance of a 3M product, user is solely responsible for evaluating the 3M product and determining whether it is fit for a particular purpose and suitable for user's method of application.

Warranty, Limited Remedy, and Disclaimer: Unless an additional warranty is specifically stated on the applicable 3M product packaging or product literature, 3M warrants that each 3M product meets the applicable 3M product specification at the time 3M ships the product. 3M MAKES NO OTHER WARRANTIES OR CONDITIONS, EXPRESS OR IMPLIED, INCLUDING, BUT NOT LIMITED TO, ANY IMPLIED WARRANTY OR CONDITION OF MERCHANTABILITY OR FITNESS FOR A PARTICULAR PURPOSE OR ANY IMPLIED WARRANTY OR CONDITION ARISING OUT OF A COURSE OF DEALING, CUSTOM OR USAGE OF TRADE. If the 3M product does not conform to this warranty, then the sole and exclusive remedy is, at 3M's option, replacement of the 3M product or refund of the purchase price.

Limitation of Liability: Except where prohibited by law, 3M will not be liable for any loss or damage arising from the 3M product, whether direct, indirect, special, incidental or consequential, regardless of the legal theory asserted, including warranty, contract, negligence or strict liability.

3M

Electronics Materials Solutions Division

3M Center, Building 224-3N-11
St. Paul, MN 55144-1000
1-800-251-8634 phone
651-778-4244 fax
www.3M.com/electronics

3M and Bumpon are trademarks of 3M Company.
Formica is a registered trademark of the Formica Corporation.
Please recycle.
©3M 2015. All rights reserved.
60-5002-0523-6



Данный компонент на территории Российской Федерации

Вы можете приобрести в компании MosChip.

Для оперативного оформления запроса Вам необходимо перейти по данной ссылке:

<http://moschip.ru/get-element>

Вы можете разместить у нас заказ для любого Вашего проекта, будь то серийное производство или разработка единичного прибора.

В нашем ассортименте представлены ведущие мировые производители активных и пассивных электронных компонентов.

Нашей специализацией является поставка электронной компонентной базы двойного назначения, продукции таких производителей как XILINX, Intel (ex.ALTERA), Vicor, Microchip, Texas Instruments, Analog Devices, Mini-Circuits, Amphenol, Glenair.

Сотрудничество с глобальными дистрибьюторами электронных компонентов, предоставляет возможность заказывать и получать с международных складов практически любой перечень компонентов в оптимальные для Вас сроки.

На всех этапах разработки и производства наши партнеры могут получить квалифицированную поддержку опытных инженеров.

Система менеджмента качества компании отвечает требованиям в соответствии с ГОСТ Р ИСО 9001, ГОСТ РВ 0015-002 и ЭС РД 009

Офис по работе с юридическими лицами:

105318, г.Москва, ул.Щербаковская д.3, офис 1107, 1118, ДЦ «Щербаковский»

Телефон: +7 495 668-12-70 (многоканальный)

Факс: +7 495 668-12-70 (доб.304)

E-mail: info@moschip.ru

Skype отдела продаж:

moschip.ru

moschip.ru_4

moschip.ru_6

moschip.ru_9