

One-Time Programmable, Linear-Taper Digital Potentiometers

General Description

The MAX5527/MAX5528/MAX5529 linear-taper digital potentiometers perform the same function as mechanical potentiometers, replacing the mechanics with a simple 2-wire up/down digital interface. These digital potentiometers provide an optional one-time programmable feature that sets the power-on reset position of the wiper. Once the wiper position is programmed, the 2-wire interface can be disabled to prevent unwanted adjustment.

The MAX5527/MAX5528/MAX5529 provide an end-to-end resistance of 100k Ω , 50k Ω , and 10k Ω , respectively. The devices feature low temperature coefficients of 35ppm/ $^{\circ}$ C end-to-end and 5ppm/ $^{\circ}$ C ratiometric. All devices offer 64 wiper positions and operate from a single +2.7V to +5.5V supply. An ultra-low, 0.25 μ A (typ) standby supply current saves power in battery-operated applications.

The MAX5527/MAX5528/MAX5529 are available in 3mm x 3mm, 8-pin TDFN and 5mm x 3mm, 8-pin μ MAX[®] packages. Each device is guaranteed over the -40 $^{\circ}$ C to +105 $^{\circ}$ C temperature range.

Applications

Products Using One-Time Factory Calibration
Mechanical Potentiometer Replacements

Pin Configurations



μ MAX is a registered trademark of Maxim Integrated Products, Inc.

Features

- ◆ Wiper Position Stored After One-Time Fuse Programming
- ◆ 64 Tap Positions
- ◆ Wiper Position Programmed Through Simple 2-Wire Up/Down Interface
- ◆ 35ppm/ $^{\circ}$ C End-to-End Temperature Coefficient
- ◆ 5ppm/ $^{\circ}$ C Ratiometric Temperature Coefficient
- ◆ Ultra-Low 1.5 μ A (max) Static Supply Current
- ◆ +2.7V to +5.5V Single-Supply Operation
- ◆ 10k Ω , 50k Ω , and 100k Ω End-to-End Resistances
- ◆ Tiny, 3mm x 3mm, 8-Pin TDFN and 5mm x 3mm, 8-Pin μ MAX Packages

Ordering Information

PART	PIN-PACKAGE	RESISTANCE (k Ω)	TOP MARK
MAX5527GTA+	8 TDFN-EP*	100	AOG
MAX5527GUA+	8 μ MAX	100	—
MAX5528GTA+	8 TDFN-EP*	50	AOH
MAX5528GUA+	8 μ MAX	50	—
MAX5529GTA+	8 TDFN-EP*	10	AOI
MAX5529GUA+	8 μ MAX	10	—

+ Denotes a lead(Pb)-free/RoHS-compliant package.

*EP = Exposed pad.

Note: All devices are specified over the -40 $^{\circ}$ C to +105 $^{\circ}$ C operating temperature range.

Functional Diagram



One-Time Programmable, Linear-Taper Digital Potentiometers

ABSOLUTE MAXIMUM RATINGS

V _{DD} to GND	-0.3V to +6.0V	Continuous Power Dissipation (T _A = +70°C)
PV to GND	-0.3V to +12.0V	8-Pin μMAX (derate 4.5mW/°C above +70°C)
All Other Pins to GND	-0.3V to (V _{DD} + 0.3V)	8-Pin TDFN (derate 18.2mW/°C above +70°C)
Maximum Continuous Current into H, L, and W		Operating Temperature Range
MAX5527	±0.5mA	Junction Temperature
MAX5528	±1.0mA	Storage Temperature Range
MAX5529	±2.0mA	Lead Temperature (soldering, 10s)

Stresses beyond those listed under "Absolute Maximum Ratings" may cause permanent damage to the device. These are stress ratings only, and functional operation of the device at these or any other conditions beyond those indicated in the operational sections of the specifications is not implied. Exposure to absolute maximum rating conditions for extended periods may affect device reliability.

ELECTRICAL CHARACTERISTICS

(V_{DD} = +2.7V to +5.5V, V_H = V_{DD}, V_L = GND, T_A = -40°C to +105°C, unless otherwise noted. Typical values are at V_{DD} = +5.0V, T_A = +25°C.) (Note 1)

PARAMETER	SYMBOL	CONDITIONS	MIN	TYP	MAX	UNITS
DC PERFORMANCE						
Resolution			64			Taps
End-to-End Resistance		MAX5527	75	100	125	kΩ
		MAX5528	37.5	50	62.5	
		MAX5529	7.5	10	12.5	
End-to-End Resistance Temperature Coefficient	TC _R			35		ppm/°C
Resistance Ratio Temperature Coefficient		MAX5527/MAX5528		5		ppm/°C
		MAX5529		10		
Integral Nonlinearity	INL	Potentiometer configuration, no load, Figure 1		±0.025	±1	LSB
Differential Nonlinearity	DNL	Potentiometer configuration, no load, Figure 1		±0.01	±1	LSB
Full-Scale Error		Potentiometer configuration, no load, Figure 1		-0.005	-1	LSB
Zero-Scale Error		Potentiometer configuration, no load, Figure 1		+0.006	+1	LSB
Wiper Resistance (Note 2)	R _W	V _{DD} ≥ 3V		90	200	Ω
		V _{DD} < 3V		125	650	
DYNAMIC CHARACTERISTICS						
Wiper -3dB Bandwidth (Note 3)		MAX5527		100		kHz
		MAX5528		200		
		MAX5529		1000		
Total Harmonic Distortion		f = 10kHz, midscale, 1V _{RMS} R _L = 100kΩ	MAX5527		-78	dB
			MAX5528		-82	
			MAX5529		-94	

One-Time Programmable, Linear-Taper Digital Potentiometers

MAX5527/MAX5528/MAX5529

ELECTRICAL CHARACTERISTICS (continued)

($V_{DD} = +2.7V$ to $+5.5V$, $V_H = V_{DD}$, $V_L = GND$, $T_A = -40^{\circ}C$ to $+105^{\circ}C$, unless otherwise noted. Typical values are at $V_{DD} = +5.0V$, $T_A = +25^{\circ}C$.) (Note 1)

PARAMETER	SYMBOL	CONDITIONS	MIN	TYP	MAX	UNITS
DIGITAL INPUTS (\overline{CS}, U/\overline{D})						
Input High Voltage	V_{IH}		0.7 x V_{DD}			V
Input Low Voltage	V_{IL}				0.3 x V_{DD}	V
Input Current	I_{IN}			± 0.1	± 1	μA
Input Capacitance	C_{IN}			5		pF
TIMING CHARACTERISTICS (Note 4)						
U/\overline{D} Mode to \overline{CS} Setup Time	t_{CU}	Figures 2 and 3	50			ns
U/\overline{D} Mode to \overline{CS} Hold Time	t_{CI}	Figures 2 and 3	50			ns
\overline{CS} to U/\overline{D} Step Hold Time	t_{tC}	Figures 2 and 3	0			ns
U/\overline{D} Step Low Time	t_{tL}	Figures 2 and 3	100			ns
U/\overline{D} Step High Time	t_{tH}	Figures 2 and 3	100			ns
Wiper Settling Time	t_{tW}	$C_L = 0pF$, Figures 2 and 3 (Note 5)		400		ns
PV Rising Edge to \overline{CS} Falling Edge	t_{PC}	Figure 5	1			ms
\overline{CS} Falling Edge to PV Falling Edge	t_{CP}	Figure 5	5			ms
\overline{CS} Step Low Time	t_{CL}	Figure 5	5			ms
\overline{CS} Step High Time	t_{CH}	Figure 5	5			ms
PV Falling Edge to \overline{CS} Rising Edge	t_{PH}	Figure 5	1			ms
U/\overline{D} Frequency	$f_{U/\overline{D}MAX}$				5	MHz
Power-Up Time	t_{UP}	(Note 6)			1	ms
POWER SUPPLY						
Supply Voltage	V_{DD}		2.7		5.5	V
Static Supply Current	I_{DD}	$\overline{CS} = U/\overline{D} = GND$ or V_{DD}			1.5	μA
Programming Voltage	PV	$T_A < +50^{\circ}C$	10.45		11.55	V
		$T_A \geq +50^{\circ}C$	11.00		11.55	
Programming Current	I_{PV}	$V_{PV} = 11V$		4	5	mA

Note 1: All devices are production tested at $T_A = +25^{\circ}C$, and are guaranteed by design for $T_A = -40^{\circ}C$ to $+105^{\circ}C$.

Note 2: The wiper resistance is measured by driving the wiper terminal with a source of $20\mu A$ for the MAX5527, $40\mu A$ for the MAX5528, and $200\mu A$ for the MAX5529.

Note 3: Wiper at midscale with a $10pF$ load.

Note 4: Digital timing is guaranteed by design, not production tested.

Note 5: Wiper setting time is measured for a single step from U/\overline{D} transition until wiper voltage reaches 90% of final value.

Note 6: Power-up time is the period of time from when the power supply is applied, until the serial interface is ready for writing.

One-Time Programmable, Linear-Taper Digital Potentiometers

Typical Operating Characteristics

($V_{DD} = +5.0V$, $T_A = +25^\circ C$, unless otherwise noted.)

MAX5527 R-DNL ERROR vs. WIPER POSITION

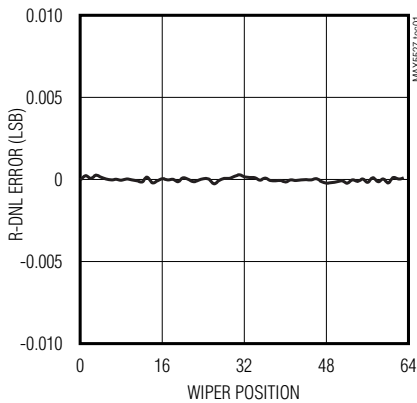

MAX5527 R-INL ERROR vs. WIPER POSITION

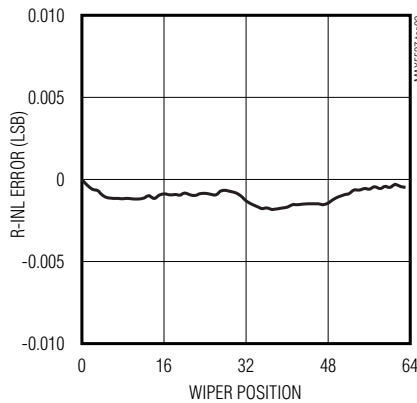

MAX5528 R-DNL ERROR vs. WIPER POSITION

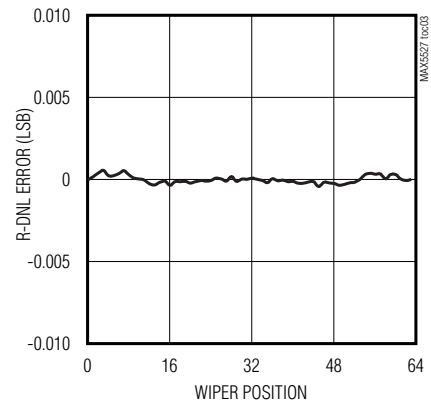

MAX5528 R-INL ERROR vs. WIPER POSITION

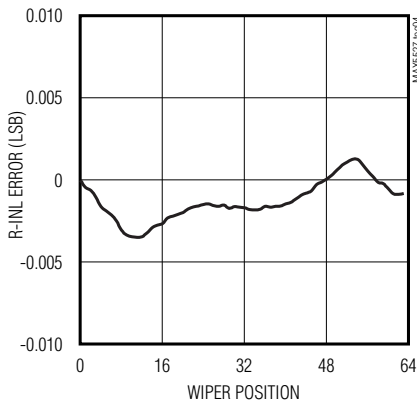

MAX5529 R-DNL ERROR vs. WIPER POSITION

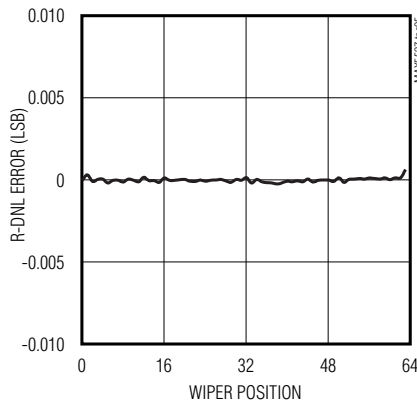

MAX5529 R-INL ERROR vs. WIPER POSITION

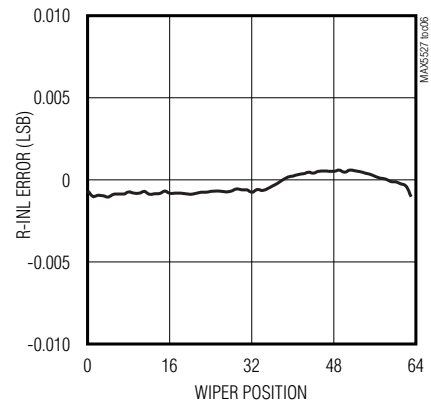

WIPER RESISTANCE vs. WIPER VOLTAGE

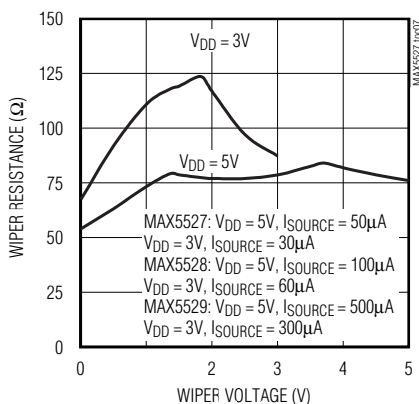

END-TO-END RESISTANCE PERCENTAGE CHANGE vs. TEMPERATURE

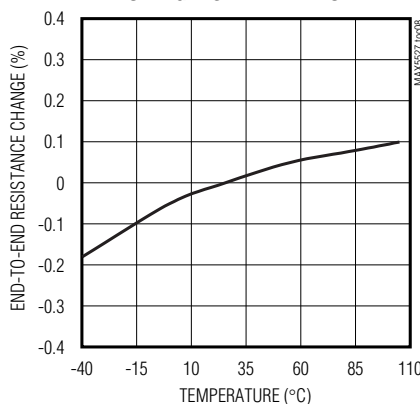

W-TO-L RESISTANCE vs. WIPER POSITION

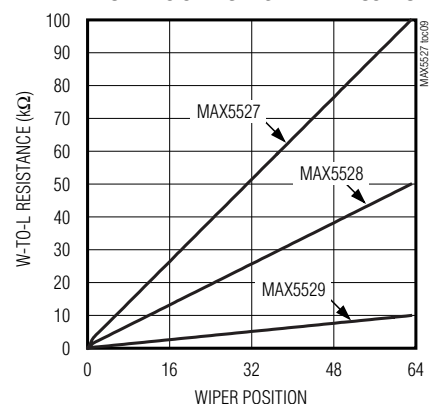

One-Time Programmable, Linear-Taper Digital Potentiometers

Typical Operating Characteristics (continued)

($V_{DD} = +5V$, $T_A = +25^\circ C$, unless otherwise noted.)

MAX5527/MAX5528/MAX5529

STATIC SUPPLY CURRENT vs. TEMPERATURE

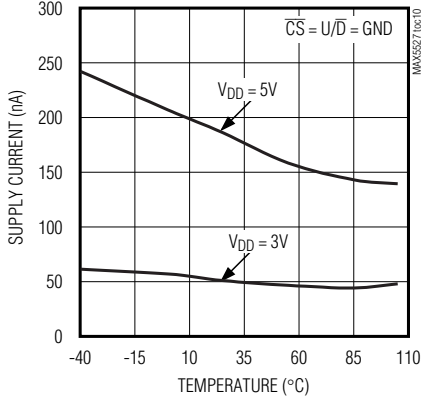

STATIC SUPPLY CURRENT vs. SUPPLY VOLTAGE

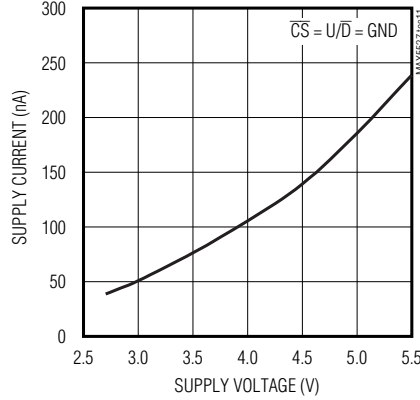

SUPPLY CURRENT vs. DIGITAL INPUT VOLTAGE

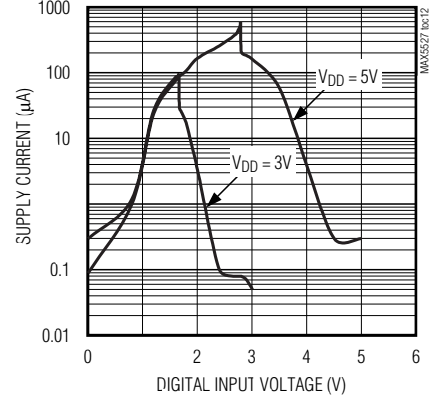

MIDSCALE WIPER RESPONSE vs. FREQUENCY

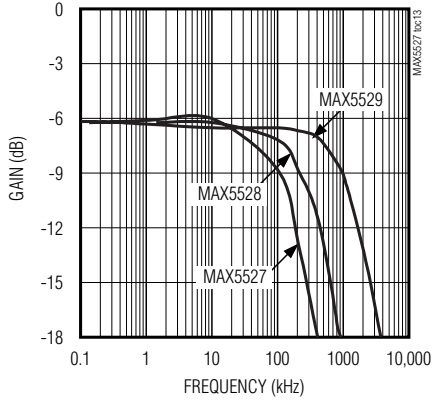

TOTAL HARMONIC DISTORTION vs. FREQUENCY

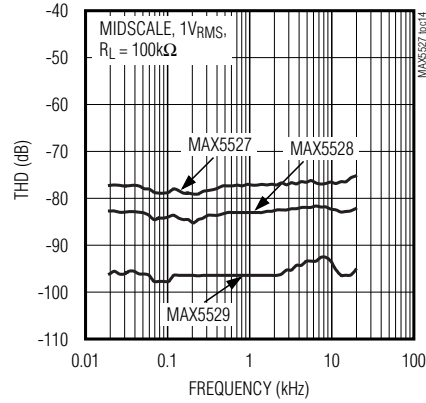

TAP-TO-TAP SWITCHING TRANSIENT

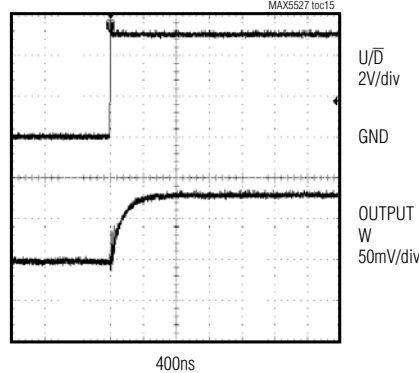

One-Time Programmable, Linear-Taper Digital Potentiometers

Typical Operating Characteristics (continued)

($V_{DD} = +5V$, $T_A = +25^\circ C$, unless otherwise noted.)

TAP-TO-TAP SWITCHING TRANSIENT

MAX5527 ttc16

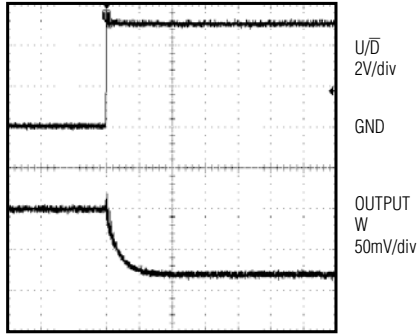

400ns

MAX5527 POWER-UP WIPER TRANSIENT

MAX5527 ttc17

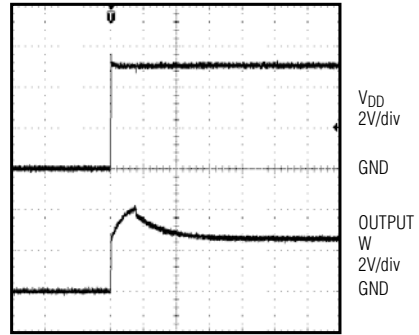

2µs

MAX5528 POWER-UP WIPER TRANSIENT

MAX5527 ttc18

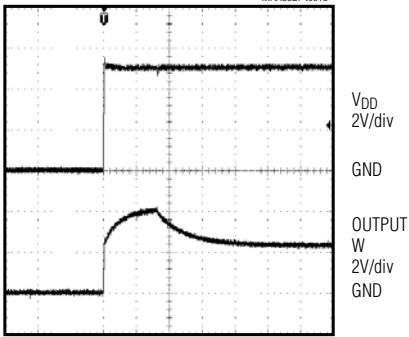

1µs

MAX5529 POWER-UP WIPER TRANSIENT

MAX5527 ttc19

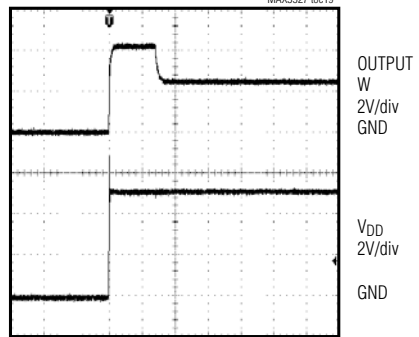

2µs

One-Time Programmable, Linear-Taper Digital Potentiometers

Pin Description

PIN	NAME	FUNCTION
1	W	Wiper Connection
2	\overline{CS}	Chip-Select Input. A high-to-low \overline{CS} transition determines the increment/decrement mode. Increment if U/\overline{D} is high, or decrement if U/\overline{D} is low. \overline{CS} is also used for one-time programming. See the <i>PV One-Time Programming</i> section.
3	V_{DD}	Supply Voltage. Bypass with a 0.1 μ F capacitor to GND.
4	GND	Ground
5	PV	One-Time Programming Voltage. Connect PV to an 11V supply at the time the device is programmed/locked, and bypass with a 22 μ F capacitor to GND. For normal operation, connect to GND or leave floating.
6	U/\overline{D}	Up/Down Control Input. When \overline{CS} is low, a low-to-high transition at U/\overline{D} increments or decrements the wiper position. See the <i>Digital Interface Operation</i> section.
7	L	Resistor Low Terminal
8	H	Resistor High Terminal
—	EP	Exposed Pad (TDFN Only). Internally connected to GND. Connect to a large ground plane to maximize thermal dissipation.

Detailed Description

The MAX5527/MAX5528/MAX5529 100k Ω /50k Ω /10k Ω end-to-end resistance digitally-controlled potentiometers offer 64 wiper tap positions accessible along the resistor array between H and L. These devices function as potentiometers or variable resistors (see Figure 1).

The wiper (W) position is adjusted sequentially through the tap positions using a simple 2-wire up/down interface. These digital potentiometers provide an optional one-time programmable feature that sets and locks the power-on reset position of the wiper (see the *PV One-Time Programming* section). Once the desired wiper position is programmed, the 2-wire interface can be disabled to prevent unwanted adjustment.

Digital Interface Operation

The MAX5527/MAX5528/MAX5529 provide two modes of operation when the serial interface is active: increment mode or decrement mode. The serial interface is only active when \overline{CS} is low.

The \overline{CS} and U/\overline{D} inputs control the position of the wiper along the resistor array. Set U/\overline{D} high to increment the MAX5527/MAX5528/MAX5529 when \overline{CS} transitions from high to low (Figure 2). Set U/\overline{D} low to decrement the MAX5527/MAX5528/MAX5529 when \overline{CS} transitions high to low (Figure 3). Once \overline{CS} is held low, each low-to-high transition at U/\overline{D} increments or decrements the wiper one position. Once the increment or decrement

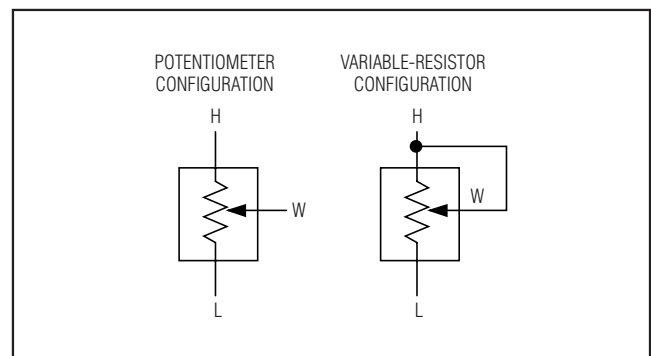

Figure 1. Potentiometer/Variable-Resistor Configuration

mode is set, the device remains in that mode until \overline{CS} goes high.

Idle U/\overline{D} high for normal operation. If U/\overline{D} is low when \overline{CS} transitions low to high, the wiper moves one additional tap in its present direction. The wiper remains in the same position when U/\overline{D} is high and \overline{CS} transitions low to high. After \overline{CS} returns high, the wiper position remains the same (Figure 4).

Additional increments do not change the wiper position when the wiper is at the maximum end of the resistor array. Additional decrements do not change the wiper position when the wiper is at the minimum end of the resistor array.

One-Time Programmable, Linear-Taper Digital Potentiometers



Figure 2. Increment-Mode Timing Diagram

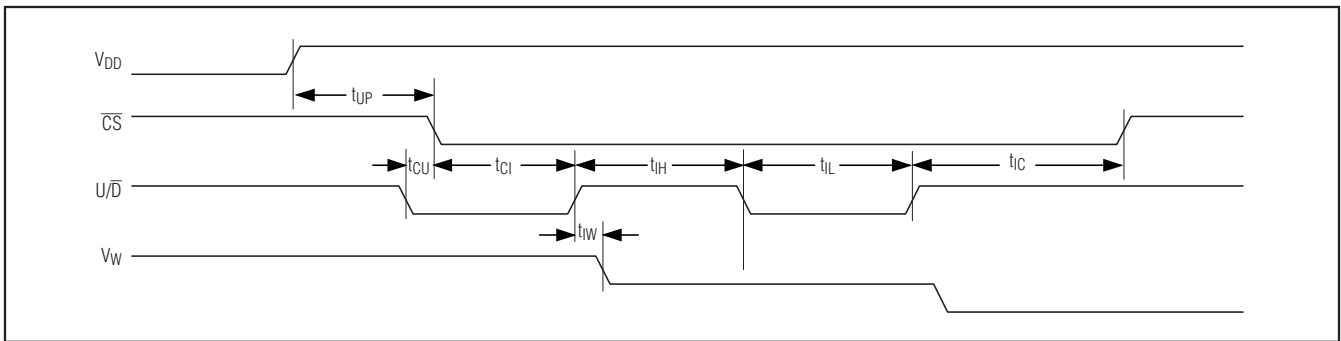

Figure 3. Decrement-Mode Timing Diagram



Figure 4. \overline{CS} Low-to-High Transition Timing Diagram

PV One-Time Programming

The MAX5527/MAX5528/MAX5529 power up and function after power-up with the wiper position set in one of three ways:

- 1) Factory default power-up position, midscale, adjustable wiper
- 2) A newly programmed power-up position, adjustable wiper
- 3) A new programmed power-up position, locked wiper

The wiper is set to the factory default position at power-up (midscale, tap 31). Connect PV to GND or leave floating to continue powering up the wiper position at midscale. See Table 1 for the default and one-time programming options.

One-Time Programmable, Linear-Taper Digital Potentiometers

MAX5527/MAX5528/MAX5529

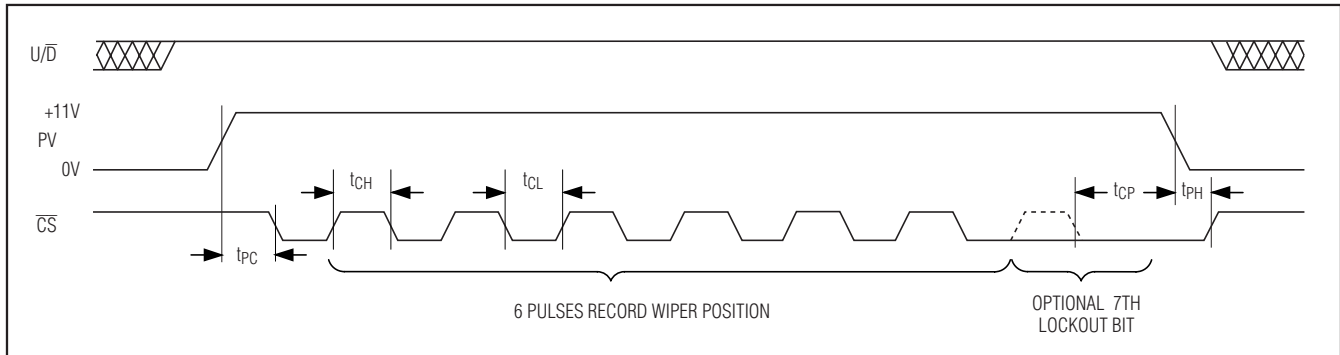

Figure 5. One-Time Program Mode, Serial-Interface Timing Diagram

Table 1. One-Time Programming Options

MODE	POWER-ON RESET WIPER POSITION	ADJUSTABLE WIPER
Factory Default (Unprogrammed)	Tap 31	Yes
Programmed by Six \overline{CS} Pulses	Programmed position	Yes
Programmed by Seven \overline{CS} Pulses	Programmed position	No

Change the wiper's power-up position using the PV one-time programming sequence after power-up (see Figure 5). After setting the wiper to the desired power-up position, perform the following six-step sequence:

- 1) Set U/\overline{D} and \overline{CS} high.
- 2) Connect an external voltage source at PV in the range of +11V to +11.55V.
- 3) Pull \overline{CS} low.
- 4a) Pulse \overline{CS} high for six cycles, consisting of \overline{CS} starting low and going high for at least t_{CH} , and then low for at least t_{CL} , to change the wiper power-up position. The wiper remains adjustable.
- 4b) Pulse \overline{CS} high for seven cycles, consisting of \overline{CS} starting low and going high for at least t_{CH} and then low for at least t_{CL} , to change the wiper power-up position and lock the wiper in that same position. The seventh \overline{CS} pulse is labeled the optional lock-out bit in Figure 5.
- 5) Connect PV to GND or release the voltage source, leaving PV floating.
- 6) Pull \overline{CS} high.

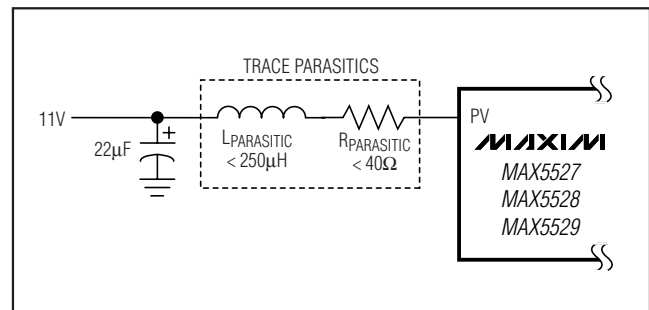

Figure 6. PV Power-Supply Decoupling

Pulse \overline{CS} high for six cycles to change the wiper power-up position. The wiper position returns to this programmed position on power-up, but remains adjustable.

Pulse \overline{CS} high for seven cycles to lock the MAX5527/MAX5528/MAX5529 to a specific wiper position with no further adjustments allowed. This effectively converts the potentiometer to a fixed resistor-divider. The seventh pulse locks the wiper position and disables the up/down interface. Once locked, connect U/\overline{D} and \overline{CS} high, low, or leave them floating without increasing the supply current (see Table 1).

If six clock pulses are used, the interface is enabled and the device can be put into program mode again. However, the part uses one-time programmable (OTP) memory and should be programmed only once. If the part is programmed more than once, all applied values are ORed together. Thus, if 010101 is programmed the first time and 101010 is programmed the second time, the result will be 111111.

The external PV power supply must source at least 5mA and have a good transient response. Decouple the PV power supply with a 22µF capacitor to GND. Ensure that no more than 250µH of inductance and/or 40Ω of parasitic resistance exists between the capacitor and the device (see Figure 6).

One-Time Programmable, Linear-Taper Digital Potentiometers

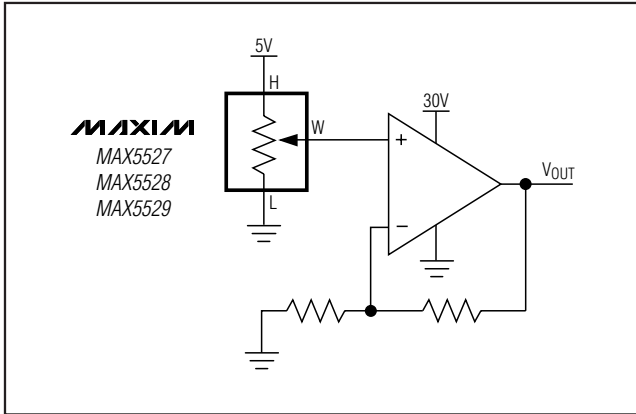

Figure 7. Positive LCD Bias Control Using a Voltage-Divider

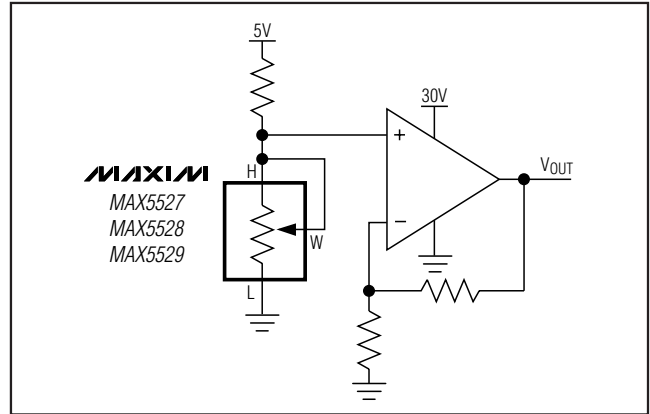

Figure 8. Positive LCD Bias Control Using a Variable Resistor

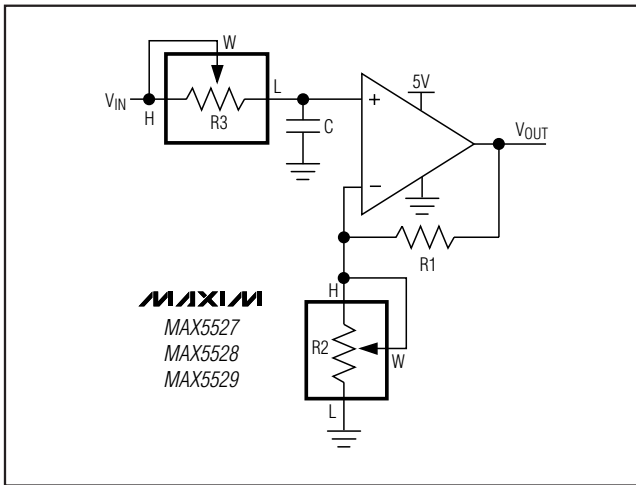

Figure 9. Programmable Filter

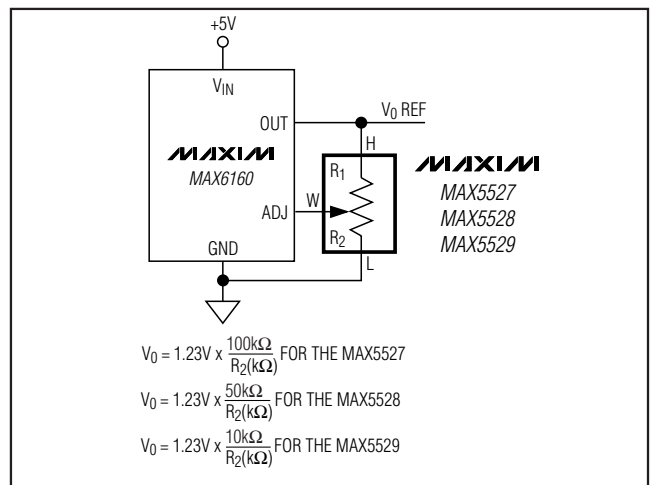

Figure 10. Adjustable Voltage Reference

Applications Information

Use the MAX5527/MAX5528/MAX5529 in applications requiring digitally controlled adjustable resistance, such as LCD contrast control where voltage biasing adjusts the display contrast, or for programmable filters with adjustable gain and/or cutoff frequency.

Positive LCD Bias Control

Figures 7 and 8 show an application where the voltage-divider or variable resistor is used to make an adjustable, positive LCD bias voltage. The op-amp provides buffering and gain to the resistor-divider network made by the potentiometer (Figure 7), or to a fixed resistor and a variable resistor (Figure 8).

Programmable Filter

Figure 9 shows the configuration for a 1st-order programmable filter. The gain of the filter is adjusted by R2, and the cutoff frequency is adjusted by R3. Use the following equations to calculate the gain (G), and the -3dB cutoff frequency (f_C), only up to frequencies one decade below the wiper -3dB bandwidth.

$$G = 1 + \frac{R_1}{R_2}$$

$$f_C = \frac{1}{2\pi \times R_3 \times C}$$

Adjustable Voltage Reference

Figure 10 shows the MAX5527/MAX5528/MAX5529 used as the feedback resistors in an adjustable-voltage reference application.

One-Time Programmable, Linear-Taper Digital Potentiometers

Layout and Power-Supply Considerations

Proper layout and power-supply bypassing can affect device performance. Bypass V_{DD} with a 0.1 μ F capacitor as close to the device as possible. When programming the wiper position, bypass PV with a 22 μ F capacitor as close to the device as possible. For a V_{DD} power supply with a slew rate greater than 1V/ μ s or in applications where power-supply overshoot is prevalent, connect a 10 Ω resistor in series to V_{DD} and bypass V_{DD} with an additional 4.7 μ F capacitor to ground.

Chip Information

TRANSISTOR COUNT: 3420

PROCESS: BiCMOS

Package Information

For the latest package outline information and land patterns, go to www.maxim-ic.com/packages. Note that "+", "#", or "-" in the package code indicates RoHS status only. Package drawings may show a different suffix character, but the drawing pertains to the package regardless of RoHS status.

PACKAGE TYPE	PACKAGE CODE	DOCUMENT NO.
8 TDFN-EP	T833+2	21-0137
8 μ MAX	U8+1	21-0036

MAX5527/MAX5528/MAX5529

One-Time Programmable, Linear-Taper Digital Potentiometers

Revision History

REVISION NUMBER	REVISION DATE	DESCRIPTION	PAGES CHANGED
0	5/05	Initial release	—
1	7/09	Added lead-free note to the <i>Ordering Information</i> . Added exposed pad information to the <i>Pin Description</i> . Added text to <i>PV One-Time Programming</i> section.	1, 7, 9

Maxim cannot assume responsibility for use of any circuitry other than circuitry entirely embodied in a Maxim product. No circuit patent licenses are implied. Maxim reserves the right to change the circuitry and specifications without notice at any time.

12 **Maxim Integrated Products, 120 San Gabriel Drive, Sunnyvale, CA 94086 408-737-7600**

Данный компонент на территории Российской Федерации

Вы можете приобрести в компании MosChip.

Для оперативного оформления запроса Вам необходимо перейти по данной ссылке:

<http://moschip.ru/get-element>

Вы можете разместить у нас заказ для любого Вашего проекта, будь то серийное производство или разработка единичного прибора.

В нашем ассортименте представлены ведущие мировые производители активных и пассивных электронных компонентов.

Нашей специализацией является поставка электронной компонентной базы двойного назначения, продукции таких производителей как XILINX, Intel (ex.ALTERA), Vicor, Microchip, Texas Instruments, Analog Devices, Mini-Circuits, Amphenol, Glenair.

Сотрудничество с глобальными дистрибьюторами электронных компонентов, предоставляет возможность заказывать и получать с международных складов практически любой перечень компонентов в оптимальные для Вас сроки.

На всех этапах разработки и производства наши партнеры могут получить квалифицированную поддержку опытных инженеров.

Система менеджмента качества компании отвечает требованиям в соответствии с ГОСТ Р ИСО 9001, ГОСТ РВ 0015-002 и ЭС РД 009

Офис по работе с юридическими лицами:

105318, г.Москва, ул.Щербаковская д.3, офис 1107, 1118, ДЦ «Щербаковский»

Телефон: +7 495 668-12-70 (многоканальный)

Факс: +7 495 668-12-70 (доб.304)

E-mail: info@moschip.ru

Skype отдела продаж:

moschip.ru

moschip.ru_4

moschip.ru_6

moschip.ru_9