

MABA-010061-CF4FA0



Transformer, 1:4 Flux Coupled Transformer
5 to 100 MHz

M/A-COM Products
Rev. V1

Features

- Surface mount
- 1:4 Impedance ratio
- Centre tap on Secondary
- 260°C reflow compatible
- RoHS* compliant and lead free
- Available on tape and reel

Description

M/A Com's MABA-010061-CF4FA0 is a 1:4 RF Flux coupled transformer in a low cost, surface mount package. Ideally suited for broadband CATV applications.

Schematic

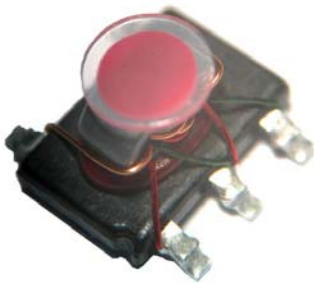
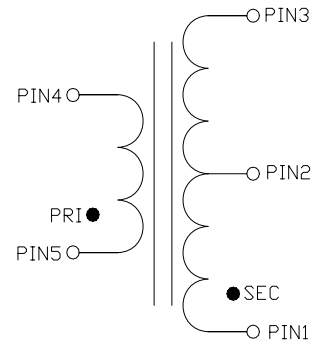

Case style

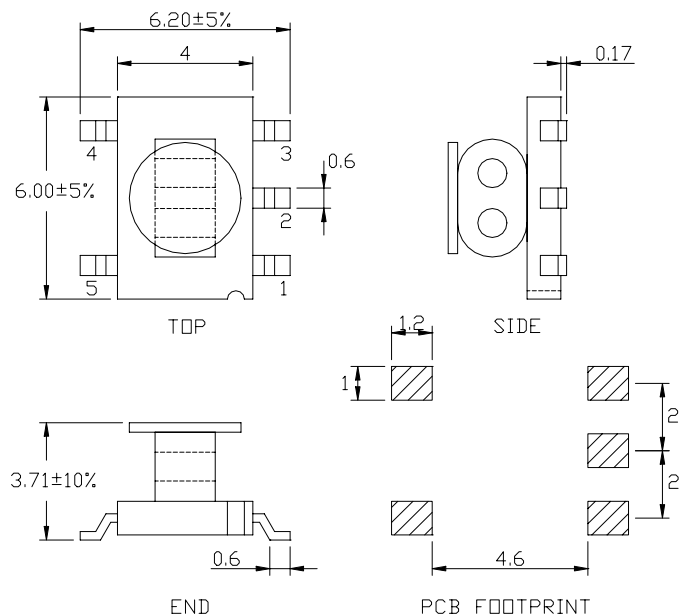

Pin Configuration

Pin no.	Function
1	Secondary dot
2	Secondary Centre Tap
3	Secondary
4	Primary
5	Primary Dot

* Restrictions on Hazardous Substances, European Union Directive 2002/95/EC.

ADVANCED: Data Sheets contain information regarding a product MA-COM Technical Solutions is considering for development. Performance is based on target specifications, simulated results, and/or prototype measurements. Commitment to develop is not guaranteed.

PRELIMINARY: Data Sheets contain information regarding a product MA-COM Technical Solutions has under development. Performance is based on engineering tests. Specifications are typical.

Mechanical outline has been fixed. Engineering samples and/or test data may be available. Commitment to produce in volume is not guaranteed.

• **North America** Tel: 800.366.2266 / Fax: 978.366.2266

• **Europe** Tel: 44.1908.574.200 / Fax: 44.1908.574.300

• **Asia/Pacific** Tel: 81.44.844.8296 / Fax: 81.44.844.8298

Visit www.macomtech.com for additional data sheets and product information.

MA-COM Technical Solutions and its affiliates reserve the right to make changes to the product(s) or information contained herein without notice.

Electrical Specifications: $T_A = 25^\circ\text{C}$, 0dBm , $Z_0 = 75\Omega$, $P_{in} = 0\text{dBm}$

Parameter	Frequency	Units	Min	Typ	Max
Insertion Loss	5 - 100 MHz	dB	-	1.22	1.5
Amplitude Unbalance (Nominal 0dB)	5 - 100 MHz	dB	-	0.01	± 0.1
Phase Unbalance (Nominal 180°)	5 - 100 MHz	°	-	0.05	± 1.0
Input Return Loss	5 - 65 MHz	dB	15	19	-
	65 - 200 MHz	dB	16	18	-

Recommended Maximum Ratings

Parameter	Value
Input power	At least +28dBm (631mW)
DC current (tested at 5V)	At least 600mA
Operating Temperature	-40°C to +85°C
Storage Temperature	-55°C to +100°C

Application Circuit

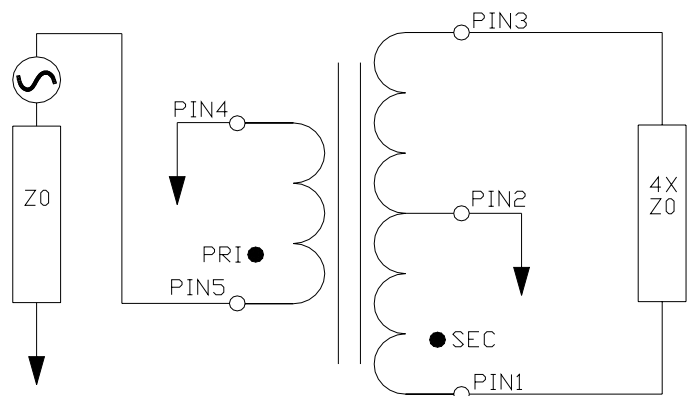

MABA-010061-CF4FA0



Transformer, 1:4 Flux Coupled Transformer
5 to 100 MHz

M/A-COM Products
Rev. V1

Typical Performance Curves: $T_A = 25^\circ\text{C}$, 0dBm , $Z_0 = 75\Omega$, $P_{in} = 0\text{dBm}$

Insertion Loss 1: (Pin 5 to 1)

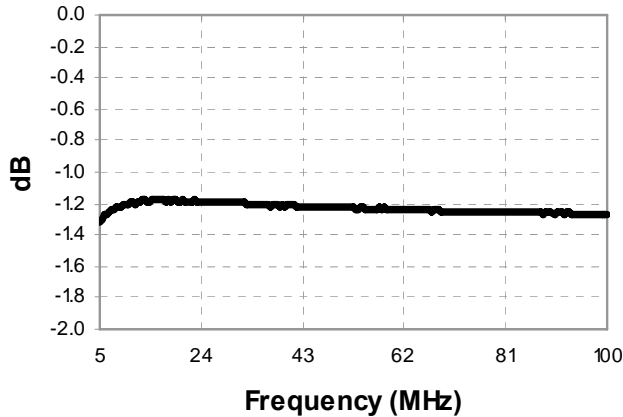

Insertion Loss 2: (Pin 5 to 3)

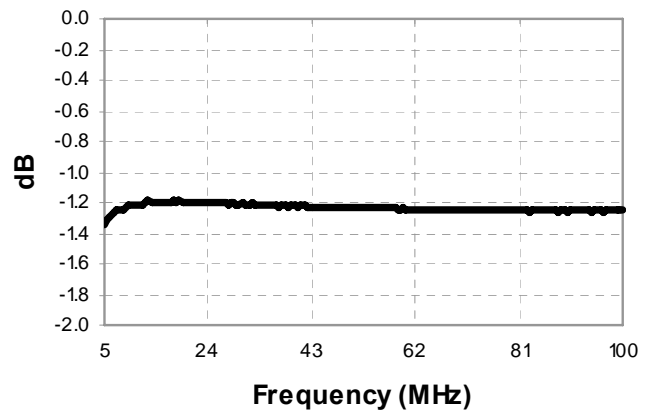

Amplitude Balance

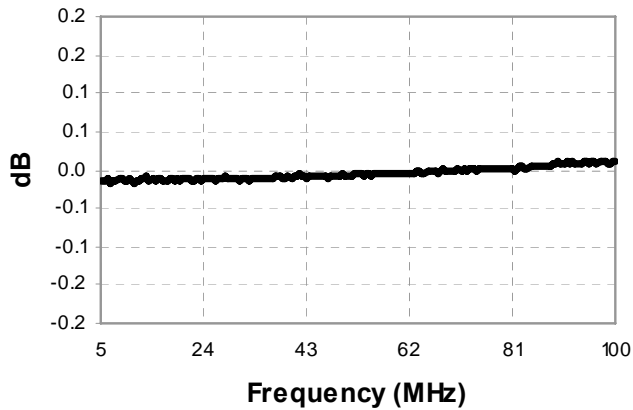

Phase Balance

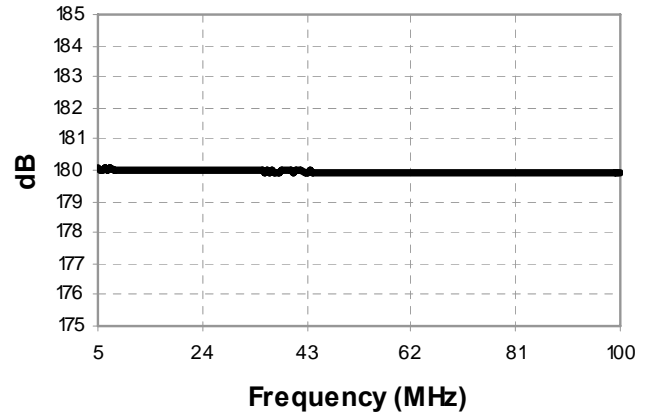

Return Loss: Input (Pin 5)

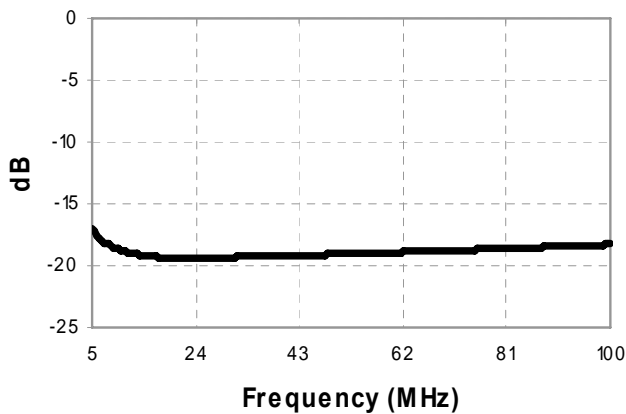

ADVANCED: Data Sheets contain information regarding a product MA-COM Technical Solutions is considering for development. Performance is based on target specifications, simulated results, and/or prototype measurements. Commitment to develop is not guaranteed.

PRELIMINARY: Data Sheets contain information regarding a product MA-COM Technical Solutions has under development. Performance is based on engineering tests. Specifications are typical. Mechanical outline has been fixed. Engineering samples and/or test data may be available. Commitment to produce in volume is not guaranteed.

• **North America** Tel: 800.366.2266 / Fax: 978.366.2266
• **Europe** Tel: 44.1908.574.200 / Fax: 44.1908.574.300
• **Asia/Pacific** Tel: 81.44.844.8296 / Fax: 81.44.844.8298

Visit www.macomtech.com for additional data sheets and product information.

MA-COM Technical Solutions and its affiliates reserve the right to make changes to the product(s) or information contained herein without notice.

MABA-010061-CF4FA0



Transformer, 1:4 Flux Coupled Transformer
5 to 100 MHz

M/A-COM Products
Rev. V1

Tape & Reel Information

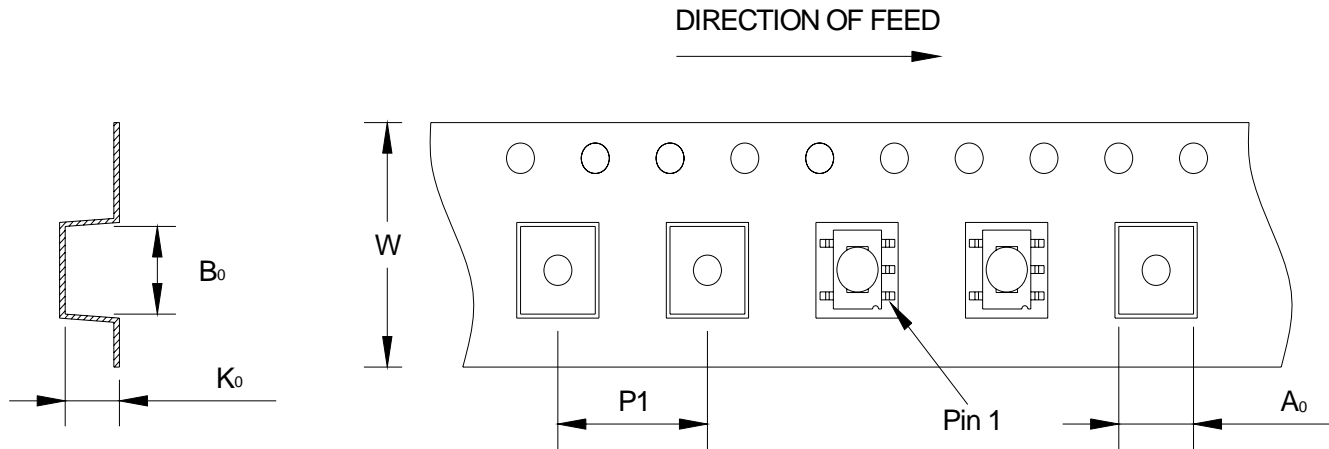

Item	Dimension
Ao	6.6mm +/- 0.1mm
Bo	6.2mm +/- 0.1mm
Ko	4.2mm +/- 0.1mm
W	16.0mm +/- 0.3mm
P1	8.00mm +/- 0.1mm

Ordering Information

Part number	Description
MABA-010061-CF4FA0	900 piece reel
MABA-010061-CF4FTB	Customer Test Board

Данный компонент на территории Российской Федерации

Вы можете приобрести в компании MosChip.

Для оперативного оформления запроса Вам необходимо перейти по данной ссылке:

<http://moschip.ru/get-element>

Вы можете разместить у нас заказ для любого Вашего проекта, будь то серийное производство или разработка единичного прибора.

В нашем ассортименте представлены ведущие мировые производители активных и пассивных электронных компонентов.

Нашей специализацией является поставка электронной компонентной базы двойного назначения, продукции таких производителей как XILINX, Intel (ex.ALTERA), Vicor, Microchip, Texas Instruments, Analog Devices, Mini-Circuits, Amphenol, Glenair.

Сотрудничество с глобальными дистрибьюторами электронных компонентов, предоставляет возможность заказывать и получать с международных складов практически любой перечень компонентов в оптимальные для Вас сроки.

На всех этапах разработки и производства наши партнеры могут получить квалифицированную поддержку опытных инженеров.

Система менеджмента качества компании отвечает требованиям в соответствии с ГОСТ Р ИСО 9001, ГОСТ РВ 0015-002 и ЭС РД 009

Офис по работе с юридическими лицами:

105318, г.Москва, ул.Щербаковская д.3, офис 1107, 1118, ДЦ «Щербаковский»

Телефон: +7 495 668-12-70 (многоканальный)

Факс: +7 495 668-12-70 (доб.304)

E-mail: info@moschip.ru

Skype отдела продаж:

moschip.ru

moschip.ru_4

moschip.ru_6

moschip.ru_9