

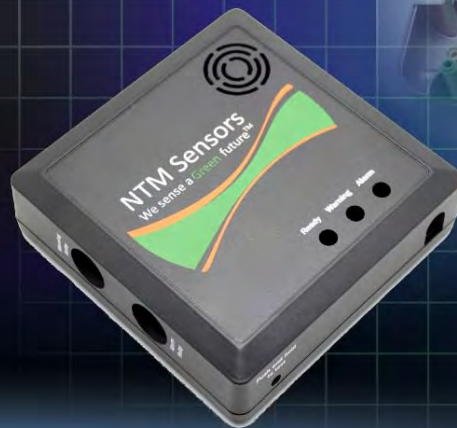

Ordering a market-ready enclosure® is made fast and affordable with our complete in-house capabilities. New Age provides machined openings to fit your PCB, pad printing for your graphics, custom enclosures, custom colors, final assembly, testing and fulfillment services to save you additional time and money. Ask your representative for a free quote today 805-595-1310.

Fast and Affordable Customization

**CNC Modifications
Pad Printing
Colored Resins
EMI/RF Shielding
Custom Enclosure
Assembly & Testing**



ISO quality
off-the-shelf
to market-ready®

NEW AGE ENCLOSURES

www.NewAgeEnclosures.com

4330 Santa Fe Road • San Luis Obispo, CA 93401 • T 805.595.1310 • F 805.595.1024

NOTES: UNLESS OTHERWISE SPECIFIED

1. CORNERS DRAWN SHARP TO BE R.005 MAXIMUM.
2. EXTERIOR SURFACE TEXTURE TO BE EQUIVELANT TO MT-11020.
3. ALL INSIDE RADII .010R. ALL OUTSIDE RADII .020R MAX, UNLESS OTHERWISE SPECIFIED.
4. ALL EXTERNAL DIMENSIONS AFFECTED BY THE DRAFT APPLY AT THE LARGE END OF THE FEATURE, AND ALL INTERNAL FEATURES AFFECTED BY THE DRAFT APPLY AT THE SMALL END OF THE FEATURE UNLESS OTHERWISE SPECIFIED.
5. 1 DEGREE DRAFT IN THE DIRECTION OF PULL IS PERMISSIBLE UNLESS OTHERWISE SPECIFIED.
6. ASSEMBLY SCREWS FOR THE ENCLOSURE INCLUDED.
7. MATERIAL / COLOR: ABS PLASTIC IS STANDARD IN BLACK OR WHITE. CUSTOM MATERIALS AND COLORS ARE AVAILABLE UPON REQUEST FOR QUOTE.
8. PCB SIZES ARE RECOMMENDATIONS ONLY. FINAL SIZES AND VERIFICATION OF IT'S FIT ARE THE SOLE RESPONSIBILITY OF OEM.
9. STANDARD OR CUSTOM LABEL RECESSES ARE AVAILABLE UPON REQUEST FOR QUOTE.

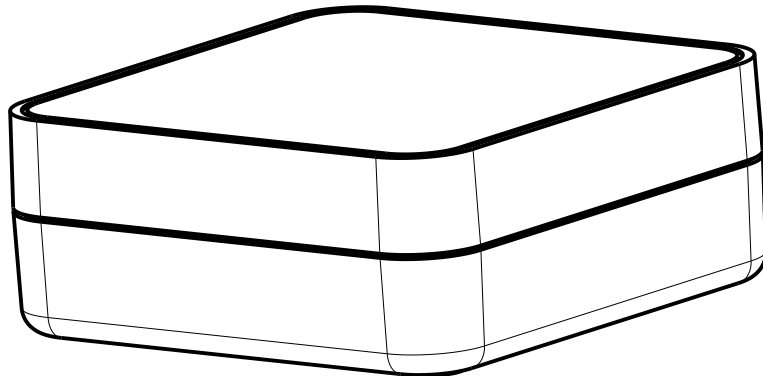

SCALE 0.750

R E V I S I O N					
REV.	DRAWN BY	ECO No	DESCRIPTION	DATE	APPROVED
A	M BOYER		PRELIMINARY RELEASE	24-Dec-10	D.C.
B	M BOYER		REVISE PER MEETING 01-Mar-11	02-Mar-11	D.C.
C	M BOYER		CHANGE TITLE FROM "4AA SQUARE"	03-Mar-11	D.C.
D	M BOYER		REMOVE 9V OPTION, INCLUDE Wii BATTERY	06-May-11	D.C.
E	M BOYER		ADD BATTERY RIBS AND AND UPDATE ASSEMBLY HOLES	11-Jul-11	D.C.
F	M BOYER		UPDATE DRAWING FORMAT - NO DIM CHANGES	04-Dec-12	D.C.
G	M BOYER		UPDATE KEEP OUT ZONES	18-Mar-13	D.C.
H	M BOYER		INCLUDE BATTERY SEQUENCE NUMBERS	02-Apr-13	D.C.
1.0	R CRUZ		UPDATE TO AS BUILT & RELEASE	06-Aug-13	

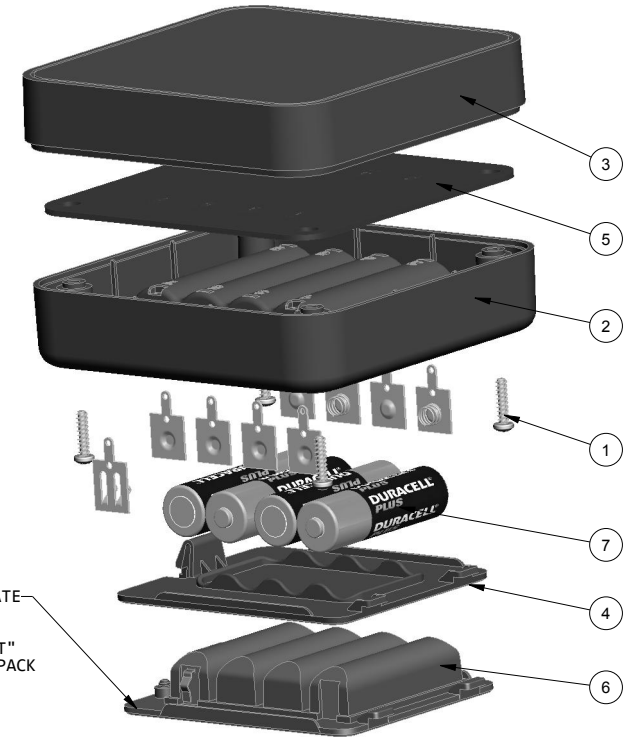

THIS ENCLOSURE CAN ACCOMODATE-
4 "AA" BATTERIES IN
PARALLEL OR SERIES.
ALTERNATE BATTERY: "Wii FIT"
LI-ION RECHARGEABLE BATTERY PACK
(4.8 Volt)

EXPLODED VIEW
SCALE 0.500

ITEM	DESCRIPTION	MATERIAL	COLOR	QTY.
10	SINGLE COIL SPRING BATTERY CONTACT	ACC-AANEG-5201	OPTIONAL	4
9	SINGLE BUTTON BATTERY CONTACT	ACC-AAPOS-5223	OPTIONAL	1
8	SINGLE BUTTON BATTERY CONTACT	ACC-AAPOS-5223	OPTIONAL	4
7	AA BATTERY	CUSTOMER SUPPLIED	REFERENCE ONLY	4
6	404017 Wii HATCH - RECHARGEABLE	CUSTOMER SUPPLIED	REFERENCE ONLY	1
5	404017 PCB - .062" THICK	CUSTOMER SUPPLIED	REFERENCE ONLY	1
4	404017 HATCH - STANDARD	ABS	BLACK or WHITE	1
3	404017 COVER - STANDARD	ABS	BLACK or WHITE	1
2	404017 BASE - STANDARD	ABS	BLACK or WHITE	1
1	#6 HiLo x .500" SCREW	ZINK PLATED	INCLUDED	4

BILL OF MATERIALS

THIRD ANGLE PROJECTION	TOLERANCES: UNLESS OTHERWISE SPECIFIED DIMENSIONS ARE IN U.S. INCHES. X.XXX = .015 X.XXXX = .001 X.XXX = .010 X.X" = 1"
DO NOT SCALE DRAWING	NEW AGE ENCLOSURES
Customer's Part No: 404017	
APPROVAL	BY DATE
CHECK	
ENG.	
SCALE	AS NOTED
DRAWN BY	24-Dec-10

NEW AGE ENCLOSURES
 4330 Santa Fe Road San Luis Obispo, CA. 93401
 ph. (805) 595-1310 fax (805) 595-1024
www.newageenclosures.com

**STANDARD - 4AA PALM-HELD
SXX-404017-XXX**

SIZE	DRAWING NAME	SHEET	REV.DOC
A	404017_R1_0	1 OF 7	1.0

404017 ASSEMBLY

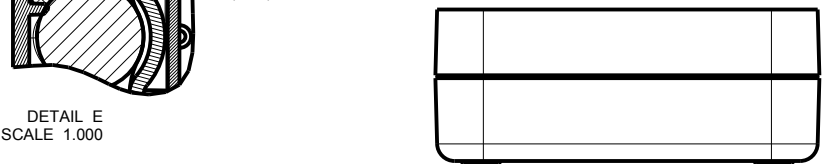
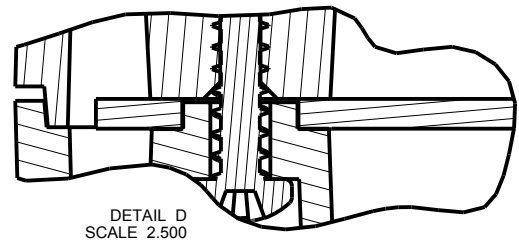
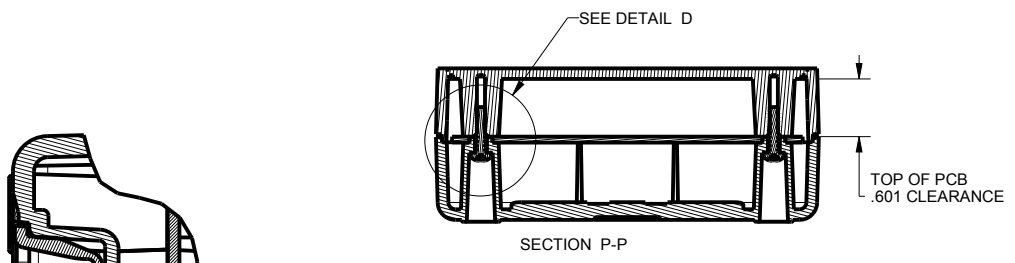
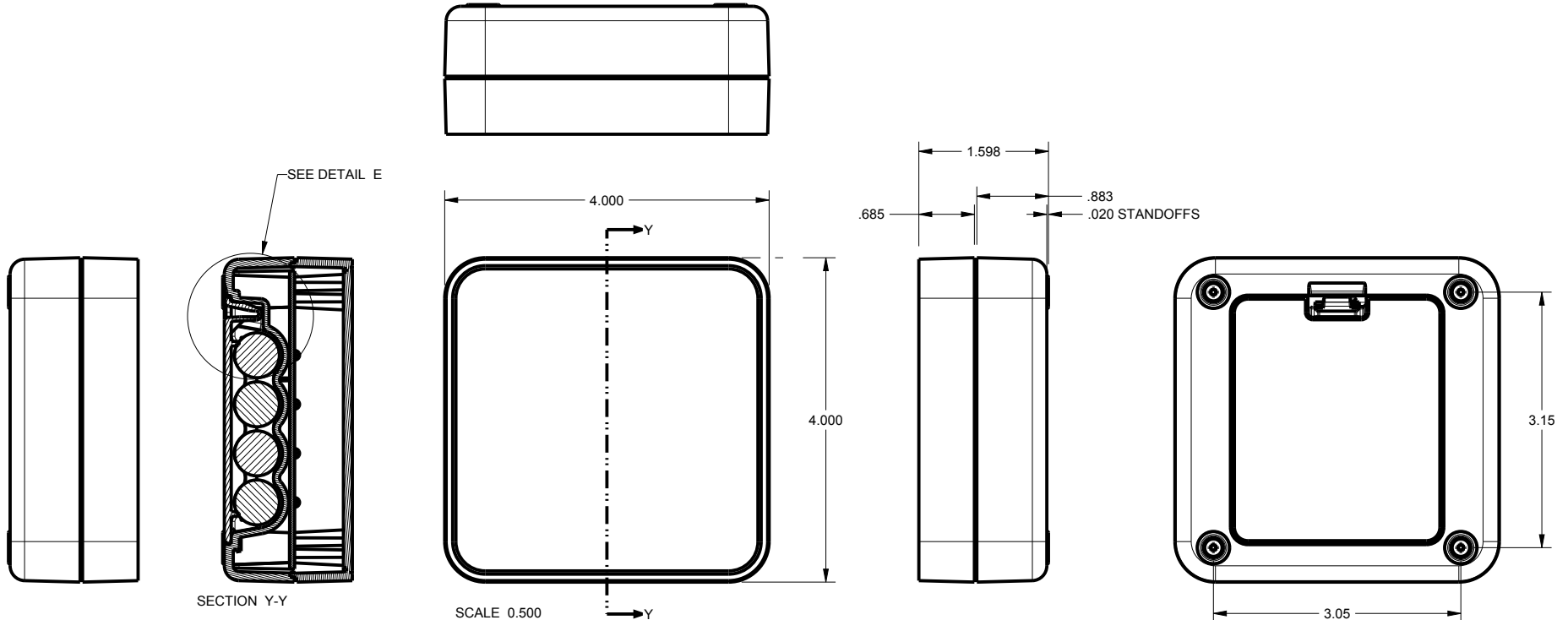

TOLERANCES: UNLESS OTHERWISE SPECIFIED DIMENSIONS ARE IN U.S. INCHES.		NEW AGE ENCLOSURES		
X.XX = .015 X.XXXX = .001		4330 Santa Fe Road San Luis Obispo, CA. 93401		
X.XXX = .010 X.X° = 1°		ph. (805) 595-1310 fax (805) 595-1024		
NEW AGE ENCLOSURES		www.newageenclosures.com		
Customer's Part No: 404017				
APPROVAL	BY	DATE	STANDARD - 4AA PALM-HELD SXX-404017-XXX	
CHECK				
ENG.				
SCALE	AS NOTED			
DRAWN BY	SIZE	DRAWING NAME	SHEET	REV. DOC
M BOYER	A	404017_R1_0	2 OF 7	1.0

404017 COVER

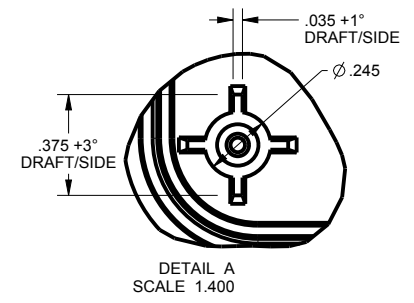
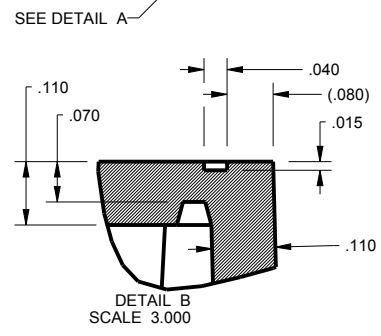
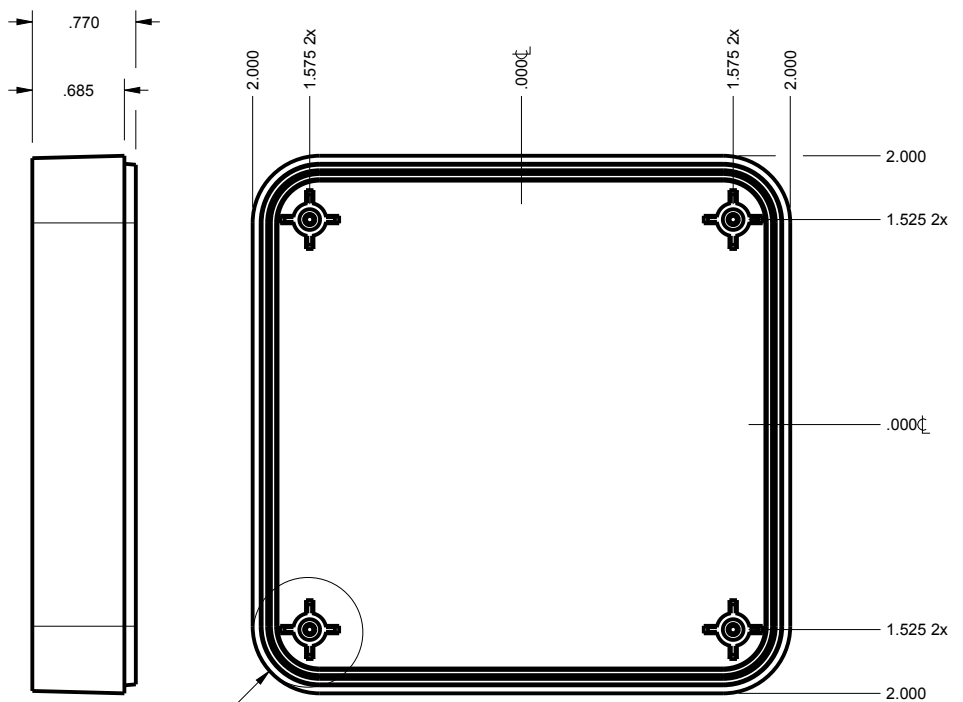
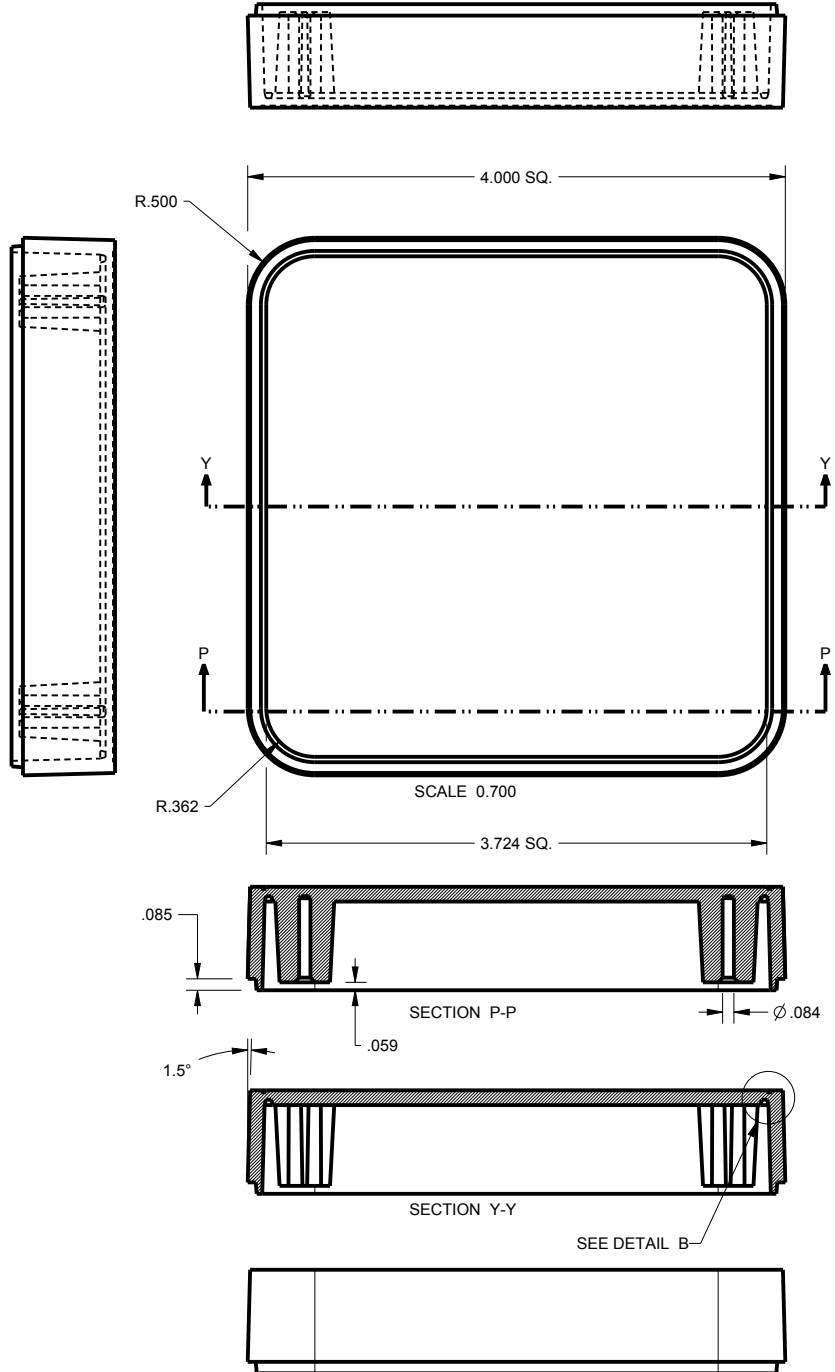

TOLERANCES: UNLESS OTHERWISE SPECIFIED
DIMENSIONS ARE IN U.S. INCHES.

X.XX = .015 X.XXXX = .001
X.XXX = .010 X.X° = 1°

NEW AGE ENCLOSURES
Customer's Part No: 404017

APPROVAL	BY	DATE
CHECK		
ENG.		
SCALE	AS NOTED	
DRAWN BY	M BOYER	
	24-Dec-10	

NEW AGE ENCLOSURES
 4330 Santa Fe Road San Luis Obispo, CA. 93401
 ph. (805) 595-1310 fax (805) 595-1024
www.newageenclosures.com

**STANDARD - 4AA PALM-HELD
 SXX-404017-XXX**

SIZE	DRAWING NAME	SHEET	REV.DOC
A	404017_R1_0	3 OF 7	1.0

404017 BASE

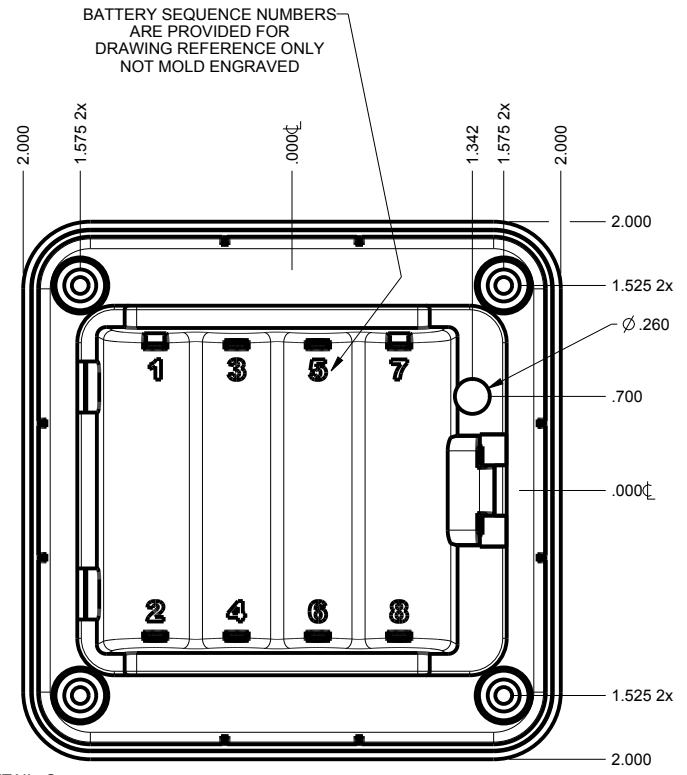
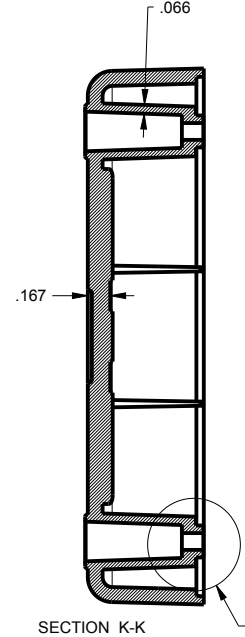
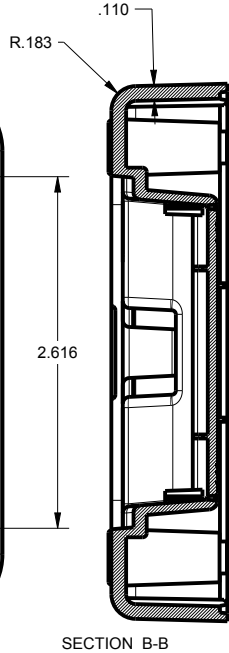
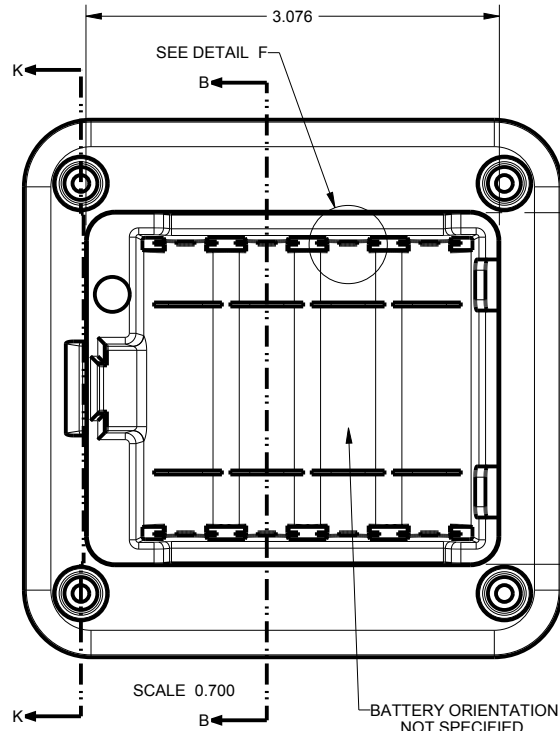
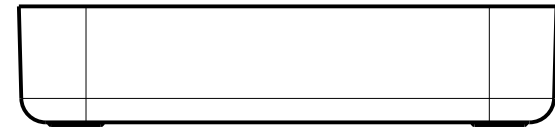

BATTERY SEQUENCE NUMBERS
ARE PROVIDED FOR
DRAWING REFERENCE ONLY
NOT MOLD ENGRAVED

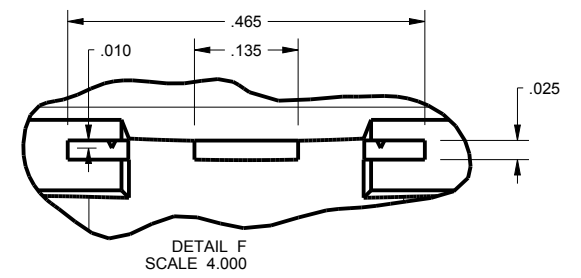
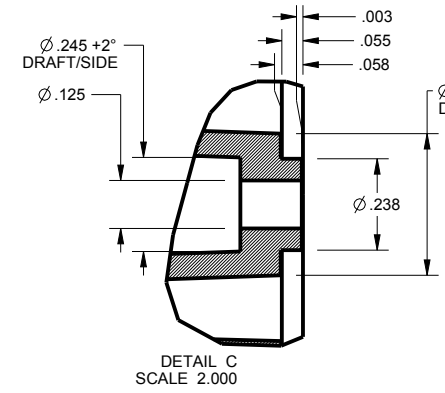
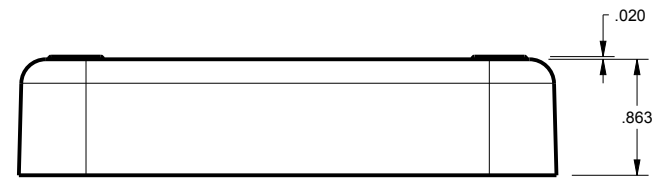

TOLERANCES: UNLESS OTHERWISE SPECIFIED DIMENSIONS ARE IN U.S. INCHES.		NEW AGE ENCLOSURES	
X.XX = .015 X.XXXX = .001		4330 Santa Fe Road San Luis Obispo, CA. 93401	
X.XXX = .010 X.X° = 1°		ph. (805) 595-1310 fax (805) 595-1024	
NEW AGE ENCLOSURES		www.newageenclosures.com	
Customer's Part No: 404017			
APPROVAL	BY	DATE	STANDARD - 4AA PALM-HELD SXX-404017-XXX
CHECK			
ENG.			
SCALE	AS NOTED		
DRAWN BY	SIZE	DRAWING NAME	SHEET
M BOYER	24-Dec-10	A 404017_R1_0	4 OF 7
			REV.DOC
			1.0

404017 HATCH

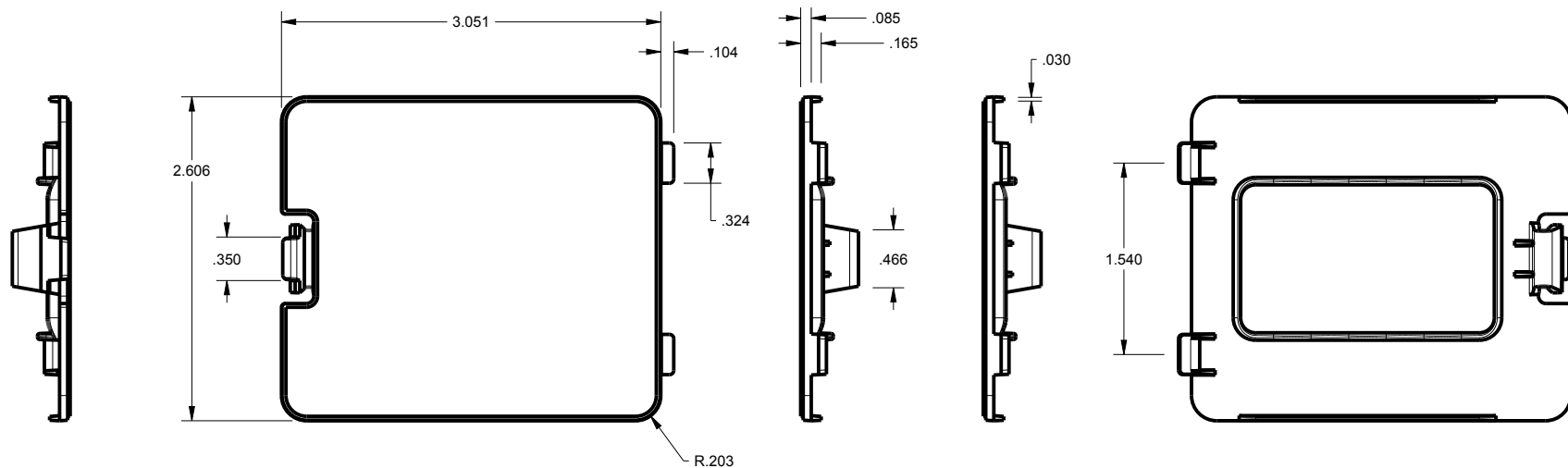

SCALE 0.700

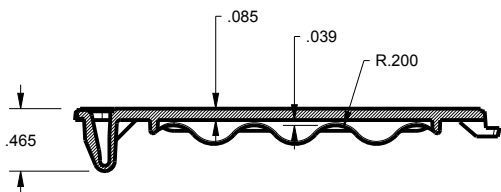

SECTION Y-Y

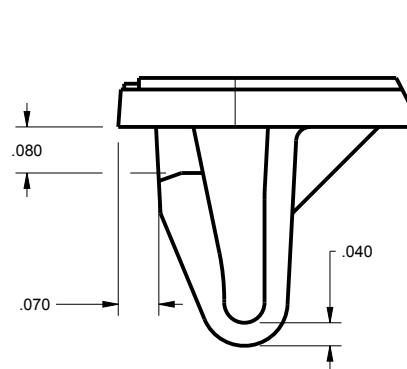

DETAIL G
SCALE 3.000

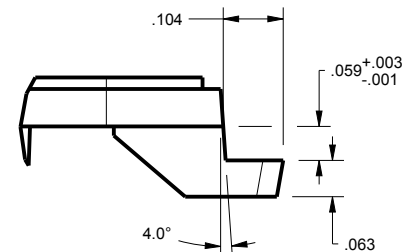

DETAIL H
SCALE 3.000

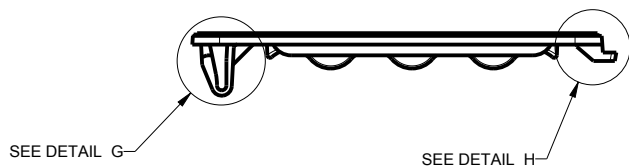

TOLERANCES: UNLESS OTHERWISE SPECIFIED
DIMENSIONS ARE IN U.S. INCHES.

X.XX = .015 X.XXXX = .001
X.XXX = .010 X.X° = 1°

NEW AGE ENCLOSURES

Customer's Part No: 404017

APPROVAL BY DATE

CHECK

ENG.

SCALE AS NOTED

DRAWN BY M BOYER

24-Dec-10

NEW AGE ENCLOSURES

4330 Santa Fe Road San Luis Obispo, CA. 93401
ph. (805) 595-1310 fax (805) 595-1024

www.newageenclosures.com

STANDARD - 4AA PALM-HELD
SXX-404017-XXX

SIZE A DRAWING NAME 404017_R1_0

SHEET 5 OF 7

REV.DOC 1.0

404017 PCB - CUSTOMER SUPPLIED

PCB SIZES ARE RECOMMENDATIONS ONLY. FINAL SIZES AND VERIFICATION OF IT'S FIT ARE THE SOLE RESPONSIBILITY OF THE OEM.

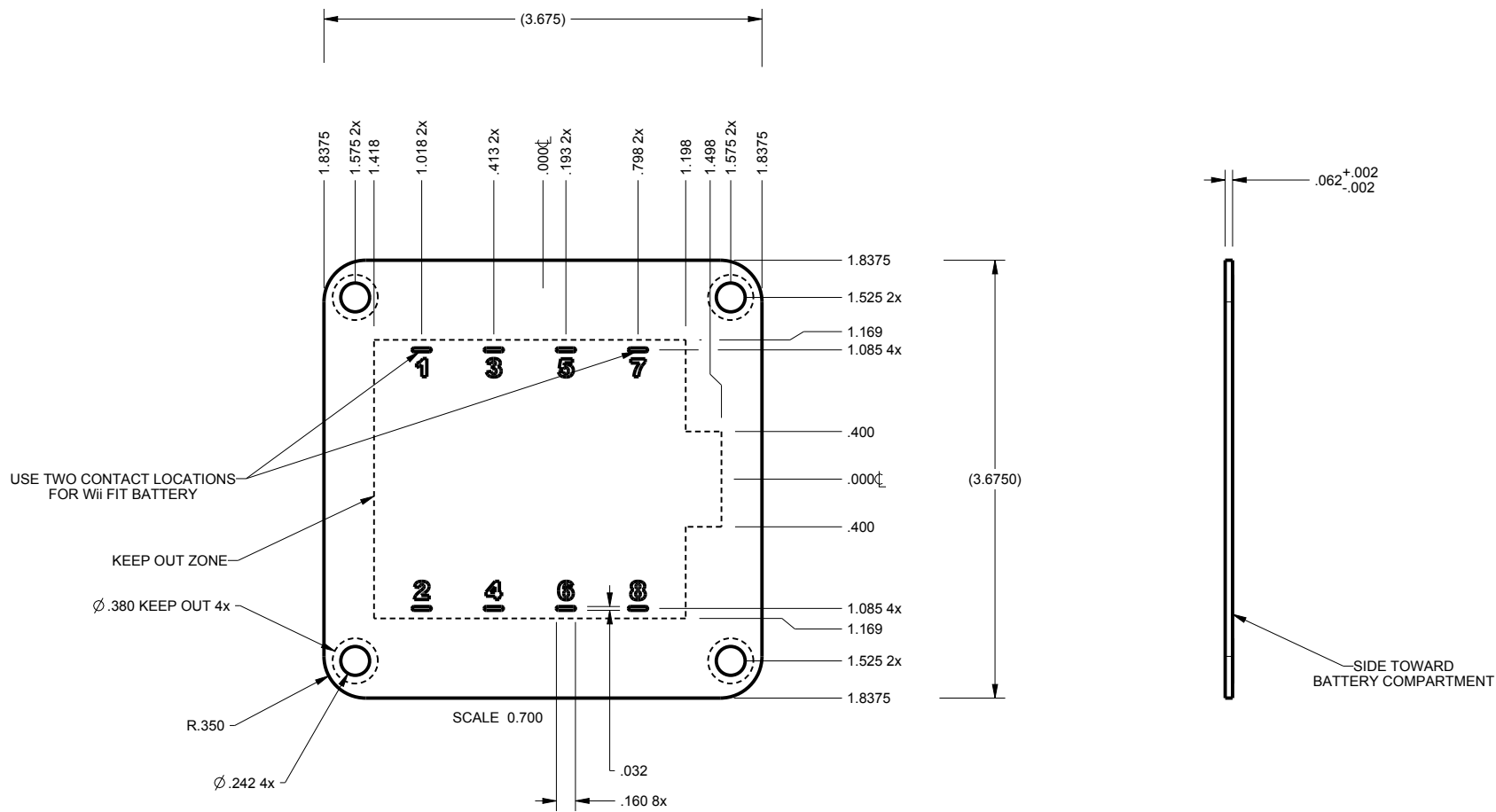

TOLERANCES: UNLESS OTHERWISE SPECIFIED DIMENSIONS ARE IN U.S. INCHES.
 X.XX = .015 X.XXXX = .001
 X.XXX = .010 X.X° = 1°

NEW AGE ENCLOSURES
 Customer's Part No: 404017

APPROVAL	BY	DATE
CHECK		
ENG.		
SCALE	AS NOTED	
DRAWN BY	M BOYER	
	24-Dec-10	

NEW AGE ENCLOSURES
 4330 Santa Fe Road San Luis Obispo, CA. 93401
 ph. (805) 595-1310 fax (805) 595-1024
www.newageenclosures.com

**STANDARD - 4AA PALM-HELD
 SXX-404017-XXX**

SIZE	DRAWING NAME	SHEET	REV.DOC
A	404017_R1_0	6 OF 7	1.0

404017 - 2nd OPERATION DETAILS

NEW AGE ENCLOSURES DELIVERS YOUR ENCLOSURE MARKET-READY WITH IN-HOUSE CNC MACHINING, PAD PRINTING, ASSEMBLY, AND FULFILLMENT.
 ALL SURFACES AND AREAS ARE AVAILABLE FOR CNC ALTERATION BY NEW AGE ENCLOSURES
 CALL (805) 595-1310 FOR PRICING AND SCHEDULE.
 THE INSIDE RADIUS OF ANY MACHINED FEATURES SHOULD BE NO SMALLER THAN .031"

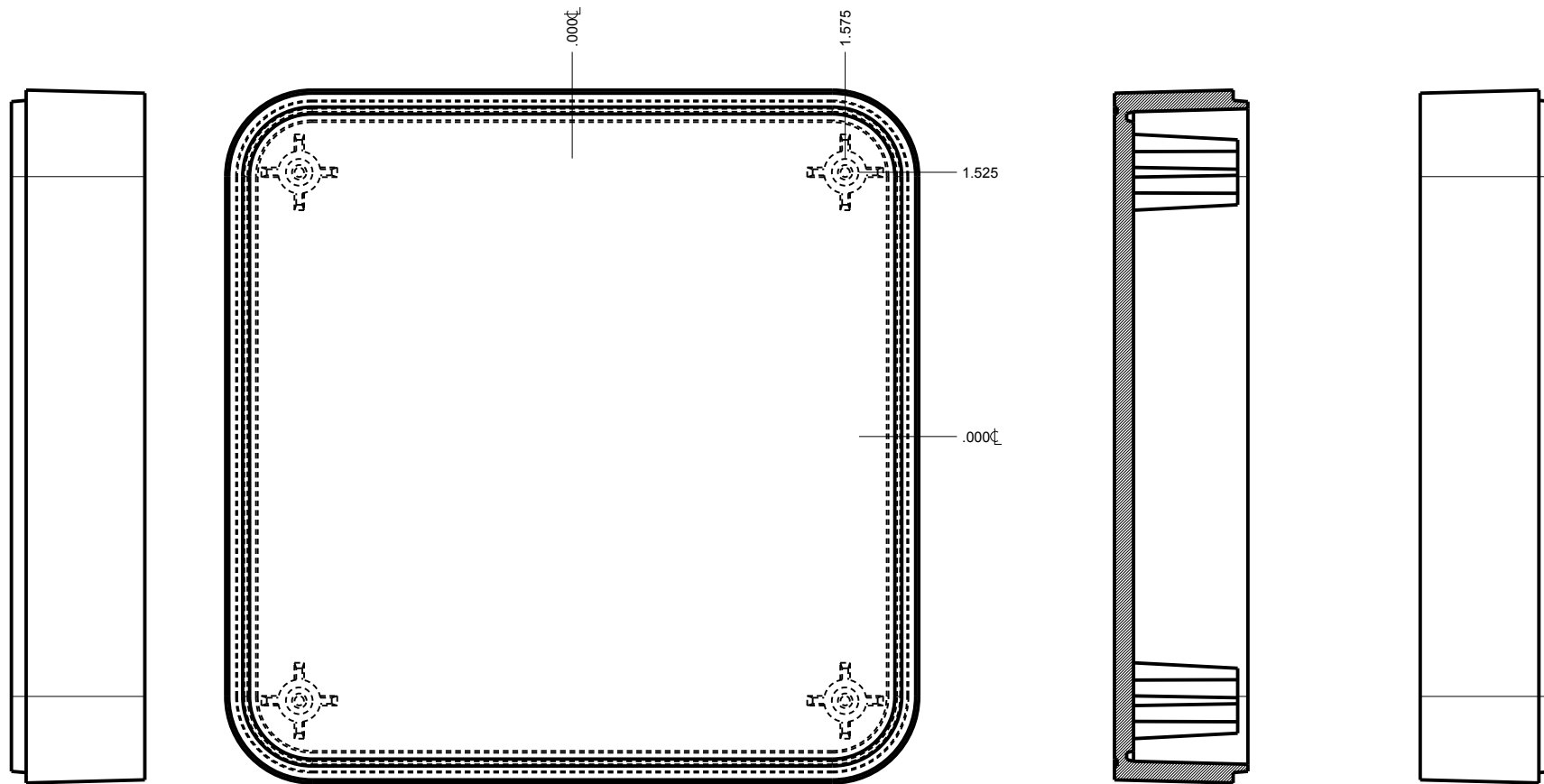

SCALE 1.000

SECTION X-X

SXX-404017-XXX COVER - ABS, BLACK

STEP	DESCRIPTION	CUTTER	FIXTURE	ORIENTATION	PROGRAM
2		T2 = .062" EM			
3					
4					

TOLERANCES: UNLESS OTHERWISE SPECIFIED
 DIMENSIONS ARE IN U.S. INCHES.
 X.XX = .015 X.XXXX = .001
 X.XXX = .010 X.X° = 1°

NEW AGE ENCLOSURES
 Customer's Part No: 404017

NEW AGE ENCLOSURES
 4330 Santa Fe Road San Luis Obispo, CA. 93401
 ph. (805) 595-1310 fax (805) 595-1024
www.newageenclosures.com

STANDARD - 4AA PALM-HELD
 SXX-404017-XXX

APPROVAL	BY	DATE
CHECK		
ENG.		
SCALE	AS NOTED	
DRAWN BY	24-Dec-10	
M BOYER		

SIZE	DRAWING NAME	SHEET	REV.DOC
A	404017_R1_0	7 OF 7	1.0

Mouser Electronics

Authorized Distributor

Click to View Pricing, Inventory, Delivery & Lifecycle Information:

[New Age Enclosures:](#)

[S1A-404017](#) [S3A-404017](#)

Данный компонент на территории Российской Федерации

Вы можете приобрести в компании MosChip.

Для оперативного оформления запроса Вам необходимо перейти по данной ссылке:

<http://moschip.ru/get-element>

Вы можете разместить у нас заказ для любого Вашего проекта, будь то серийное производство или разработка единичного прибора.

В нашем ассортименте представлены ведущие мировые производители активных и пассивных электронных компонентов.

Нашей специализацией является поставка электронной компонентной базы двойного назначения, продукции таких производителей как XILINX, Intel (ex.ALTERA), Vicor, Microchip, Texas Instruments, Analog Devices, Mini-Circuits, Amphenol, Glenair.

Сотрудничество с глобальными дистрибьюторами электронных компонентов, предоставляет возможность заказывать и получать с международных складов практически любой перечень компонентов в оптимальные для Вас сроки.

На всех этапах разработки и производства наши партнеры могут получить квалифицированную поддержку опытных инженеров.

Система менеджмента качества компании отвечает требованиям в соответствии с ГОСТ Р ИСО 9001, ГОСТ РВ 0015-002 и ЭС РД 009

Офис по работе с юридическими лицами:

105318, г.Москва, ул.Щербаковская д.3, офис 1107, 1118, ДЦ «Щербаковский»

Телефон: +7 495 668-12-70 (многоканальный)

Факс: +7 495 668-12-70 (доб.304)

E-mail: info@moschip.ru

Skype отдела продаж:

moschip.ru

moschip.ru_4

moschip.ru_6

moschip.ru_9