

# QUICK START GUIDE FOR DEMONSTRATION CIRCUIT 700

## 2.4MHZ, 2-PHASE BOOST CONVERTER

### LTC3428EDD

## DESCRIPTION

Demonstration circuit 700 is a 2.4MHz, Dual Phase Step-Up DC/DC Converter featuring the LTC3428EDD. The demo board demonstrates a dual phase DC/DC boost converter, with a 2A switch (per phase), capable of providing either 5V at 2A or 3.3V at 1.5A. The circuit demonstrates the advantages of the dual phase architecture for an effective switching frequency of 2.4MHz. Small circuit size and low component count makes the LTC3428 suitable for use in many space-

conscious applications such as handheld instruments, point-of-load converters, digital cameras, cellular phones, distributed power and networking equipment. Other integrated features include internal soft-start, antiringing control and thermal shutdown.

**Design files for this circuit board are available. Call the LTC factory.**

LTC is a trademark of Linear Technology Corporation

**Table 1. Performance Summary ( $T_A = 25^\circ\text{C}$ )**

PARAMETERS FOR 5V OUT	CONDITION	VALUE
Minimum Input Voltage		3.3V
Maximum Input Voltage		4.5V
Output Voltage $V_{OUT}$	$V_{IN} = 3.3V, I_{OUT} = 0A \text{ to } 2A$	$5V \pm 4\%$
Maximum Output Current		2A
Typical Output Ripple $V_{OUT}$	$V_{IN} = 3.3V, I_{OUT} = 2A$	20mV <sub>P-P</sub>
Typical efficiency	$V_{IN} = 5V, I_{OUT} = 2A$	87.5%
PARAMETERS FOR 3.3V OUT	CONDITION	VALUE
Minimum Input Voltage		1.8V
Maximum Input Voltage		3.3V
Output Voltage $V_{OUT}$	$V_{IN} = 1.8V \text{ to } 3V, I_{OUT} = 0A \text{ to } 1.5A$	$3.3V \pm 4\%$
Maximum Output Current		1.5A
Typical Output Ripple $V_{OUT}$	$V_{IN} = 2.5V, I_{OUT} = 1.5A$	20mV <sub>P-P</sub>
Typical efficiency	$V_{IN} = 1.8V \text{ to } 3V, I_{OUT} = 1.5A$	81%

Input capacitor C1 used only for operation with long inductive input leads. See Application Note 88 for further details.

## QUICK START PROCEDURE

Demonstration circuit 700 is easy to set up to evaluate the performance of the LTC3428EDD. Refer to Figure 1 for proper measurement equipment setup and follow the procedure below:

**NOTE:** When measuring the input or output voltage ripple, care must be taken to avoid a long ground lead on the oscilloscope probe. Measure the input or output voltage ripple by touching the probe tip directly across the Vin or Vout and GND terminals. See Figure 2 for proper scope probe technique.

**NOTE:** Steps 1-4 are for 5V operation only.

1. Place jumpers in the following positions:

**JP1** Run, JP2 on.

2. With power off, connect the input power supply to VIN and GND.
3. Turn on the power at the input.  
**NOTE:** Make sure that the input voltage does not exceed 4.5V.
4. Check for the proper output voltages.

**NOTE:** If there is no output, temporarily disconnect the load to make sure that the load is not set too high.

**NOTE:** Once the proper output voltages are established, adjust the loads within the operating range and observe the output voltage regulation, ripple voltage, efficiency and other parameters.

**NOTE:** Steps 5-9 are for 3.3V operation only.

5. Place jumper in the following positions:

**JP1** Run, JP2 Removed.

6. With power off, connect the input power supply to VIN and GND.
7. Turn on the power at the input.

**NOTE:** Make sure that the input voltage is set between 1.8V and 3.3V.

8. Check for the proper output voltages.

**NOTE:** If there is no output, temporarily disconnect the load to make sure that the load is not set too high.

9. Once the proper output voltages are established, adjust the loads within the operating range and observe the output voltage regulation, ripple voltage, efficiency and other parameters.

# QUICK START GUIDE FOR DEMONSTRATION CIRCUIT 700

## 2.4MHZ, 2-PHASE BOOST CONVERTER

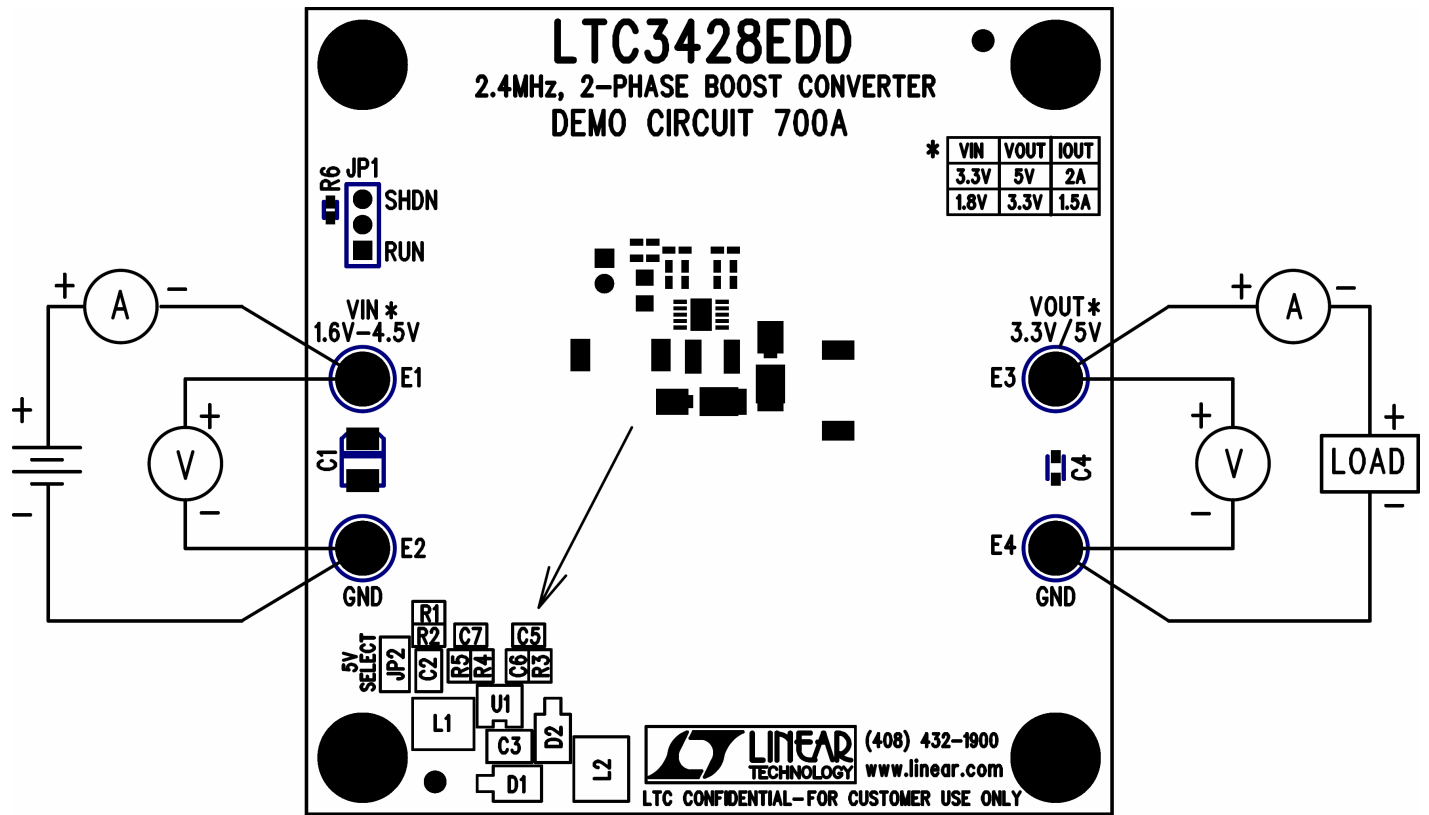

Figure 1. Proper Measurement Equipment Setup

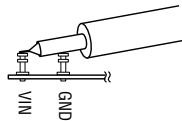
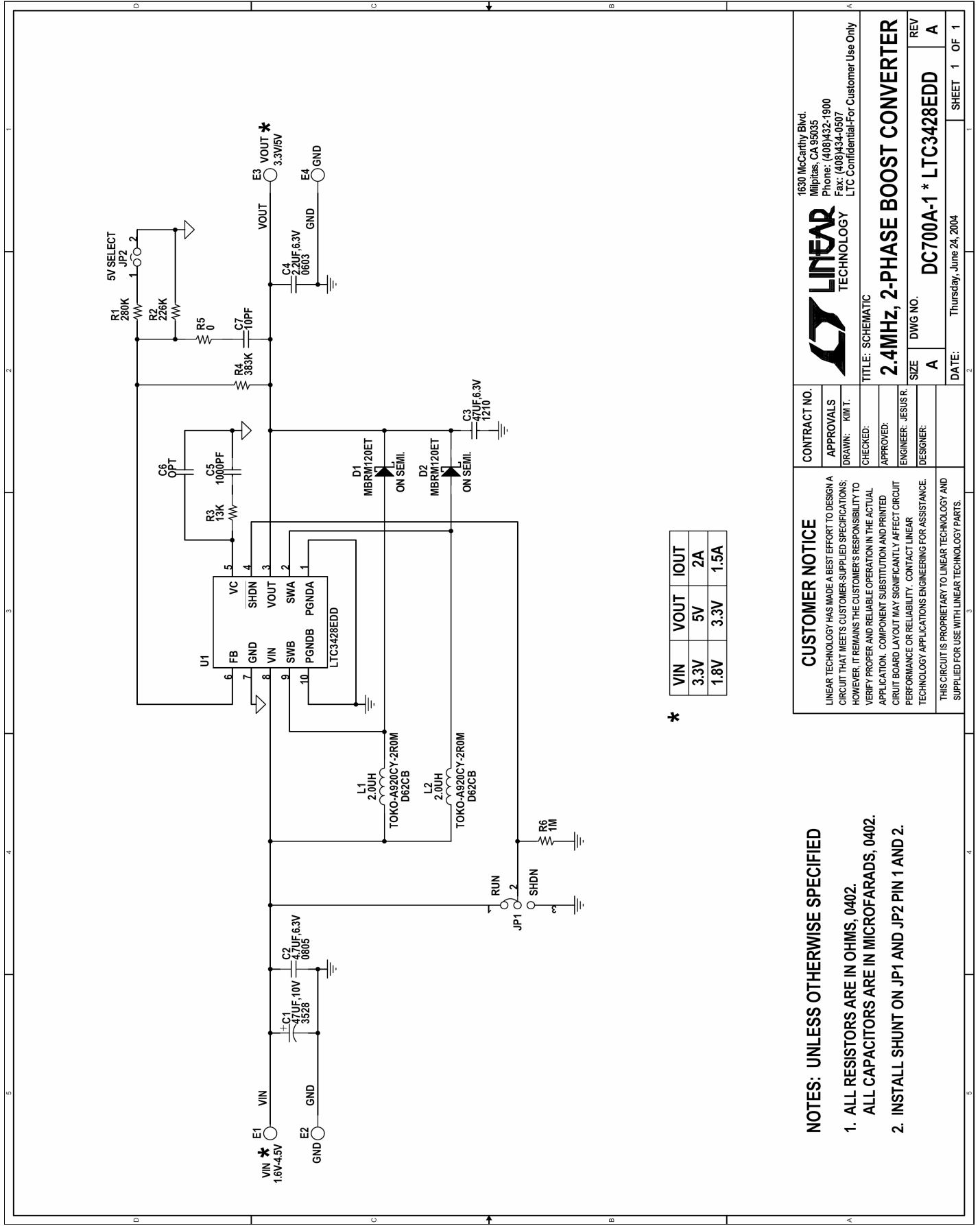

Figure 2. Measuring Input or Output Ripple

# QUICK START GUIDE FOR DEMONSTRATION CIRCUIT 700

## 2.4MHZ, 2-PHASE BOOST CONVERTER



VIN	VOUT	IOUT
3.3V	5V	2A
1.8V	3.3V	1.5A

\*

### NOTES: UNLESS OTHERWISE SPECIFIED

1. ALL RESISTORS ARE IN OHMS, 0402.  
ALL CAPACITORS ARE IN MICROFARADS, 0402.
2. INSTALL SHUNT ON JP1 AND JP2 PIN 1 AND 2.

### CUSTOMER NOTICE

LINEAR TECHNOLOGY HAS MADE A BEST EFFORT TO DESIGN A CIRCUIT THAT MEETS CUSTOMER-SUPPLIED SPECIFICATIONS; HOWEVER, IT REMAINS THE CUSTOMER'S RESPONSIBILITY TO VERIFY PROPER AND RELIABLE OPERATION IN THE ACTUAL APPLICATION. COMPONENT SUBSTITUTION AND PRINTED CIRCUIT BOARD LAYOUT MAY SIGNIFICANTLY AFFECT CIRCUIT PERFORMANCE OR RELIABILITY. CONTACT LINEAR TECHNOLOGY APPLICATIONS ENGINEERING FOR ASSISTANCE. THIS CIRCUIT IS PROPRIETARY TO LINEAR TECHNOLOGY AND SUPPLIED FOR USE WITH LINEAR TECHNOLOGY PARTS.

### CONTRACT NO.

APPROVALS

DRAWN: KIM T.

CHECKED:

APPROVED:

ENGINEER: JESUS R.

DESIGNER:



1630 McCarthy Blvd.  
Milpitas, CA 95035  
Phone: (408)432-1900  
Fax: (408)434-0507  
LTC Confidential-For Customer Use Only

TITLE: SCHEMATIC

### 2.4MHZ, 2-PHASE BOOST CONVERTER

SIZE: A

DWG NO. DC700A-1 \* LTC3428EDD

REV: A

DATE: Thursday, June 24, 2004

SHEET 1 OF 1

## Данный компонент на территории Российской Федерации

### Вы можете приобрести в компании MosChip.

Для оперативного оформления запроса Вам необходимо перейти по данной ссылке:

<http://moschip.ru/get-element>

Вы можете разместить у нас заказ для любого Вашего проекта, будь то серийное производство или разработка единичного прибора.

В нашем ассортименте представлены ведущие мировые производители активных и пассивных электронных компонентов.

Нашей специализацией является поставка электронной компонентной базы двойного назначения, продукции таких производителей как XILINX, Intel (ex.ALTERA), Vicor, Microchip, Texas Instruments, Analog Devices, Mini-Circuits, Amphenol, Glenair.

Сотрудничество с глобальными дистрибьюторами электронных компонентов, предоставляет возможность заказывать и получать с международных складов практически любой перечень компонентов в оптимальные для Вас сроки.

На всех этапах разработки и производства наши партнеры могут получить квалифицированную поддержку опытных инженеров.

Система менеджмента качества компании отвечает требованиям в соответствии с ГОСТ Р ИСО 9001, ГОСТ РВ 0015-002 и ЭС РД 009

### Офис по работе с юридическими лицами:

105318, г.Москва, ул.Щербаковская д.3, офис 1107, 1118, ДЦ «Щербаковский»

Телефон: +7 495 668-12-70 (многоканальный)

Факс: +7 495 668-12-70 (доб.304)

E-mail: [info@moschip.ru](mailto:info@moschip.ru)

Skype отдела продаж:

moschip.ru

moschip.ru\_4

moschip.ru\_6

moschip.ru\_9