

MR-MINI-RTC™ I<sup>2</sup>C Real Time Clock Board  
User Manual

# GRAVITECH.US

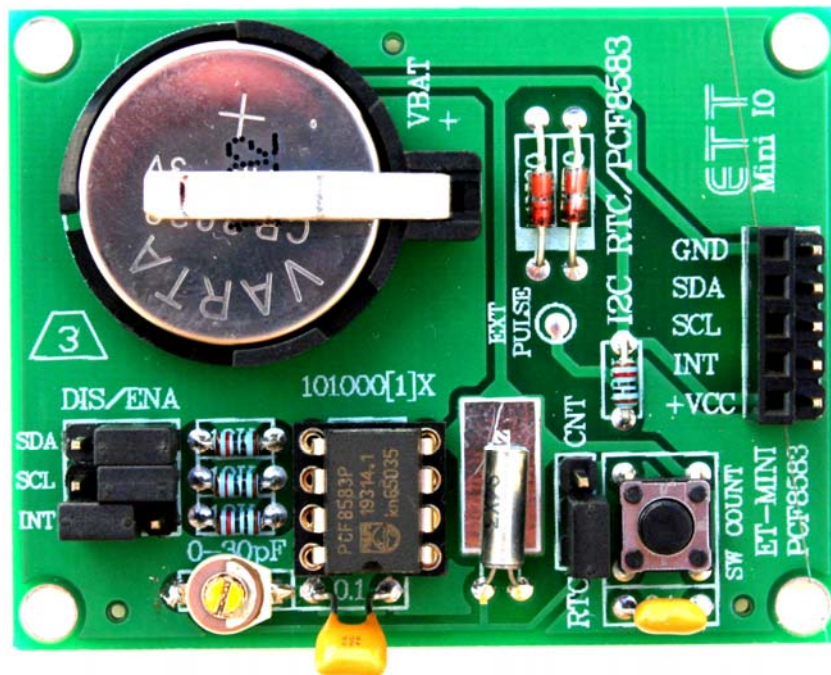

# *uResearch*

## GRAVITECH GROUP

Copyright © 2007 MicroResearch  
GRAVITECH GROUP WWW.GRAVITECH.US

# MR-MINI-RTC™ I<sup>2</sup>C Real Time Clock Board User Manual

## Description

The MR-MINI-RTC is a Real Time Clock (RTC) board. It display time base such as clock, timer, and calendar. Moreover, it can be a counter for an external clock. The data can be interface via I<sup>2</sup>C bus. There are no external components required. This makes it perfect for embedded systems that need RTC. The board is small can compact in size 2.20 x 1.70 inches.

There are two modes of operation RTC mode and counter mode. When using RTC mode, there is a variable capacitor for frequency crystal adjustment. This makes crystal create correct frequency result in accurate time base. There is a on-board battery backup when there is no power apply to the board. This enable RTC to run continuously even without power supply. When using counter mode (CNT), user can input pulse signal from external generated source via a header pin. Moreover, there is an on-board push button switch so user can generate the pulse to test or experiment with this feature.

The MR-MINI-RTC is designed base on LM2575-5 IC. It is a clock/calendar circuit based on a 2048-bit static CMOS RAM organized as 256 words by 8 bits. Addresses and data are transferred serially via the two-line bidirectional I<sup>2</sup>C bus. The built-in word address register is incremented automatically after each written or read data byte.

Please take a look at PCF8583 datasheet for more information.

## Features:

- I<sup>2</sup>C bus interface operating supply voltage: 2.5V to 6V
- Clock function with four year calendar
- 24 or 12 hour format
- Thermal shutdown and current limit protection
- On-board variable capacitor for frequency adjustment
- Jumpers setting configuration
- Small and compact in size
- Four mounting holes on each corner
- Male and female output headers

## Interfacing:

There are two set of jumpers must be configure. The first set is DIS/ENA jumpers. These jumpers connect R pulled-up to SDA, SCL and INT pins. If there are pulled-up resistors on the bus already, these jumpers need to be in disable (DIS) positions. Otherwise, the jumpers need to be on enable (ENA) position.



FIG 1: Pulled-up R enable

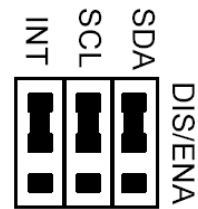

FIG 2: Pulled-up R disable

# MR-MINI-RTC™ I<sup>2</sup>C Real Time Clock Board User Manual

The second jumper is RTC/CNT position. It is an operation configuration of I<sup>2</sup>C. For RTC mode, the jumper must be set to RTC side. In CNT mode, the jumper is set at CNT position. The EXT PULSE pin then takes an input pulse from external source or from push button switch.



FIG 3: Jumper set for RTC mode FIG 4: Jumper set for CNT mode



# MR-MINI-RTC™ I<sup>2</sup>C Real Time Clock Board User Manual

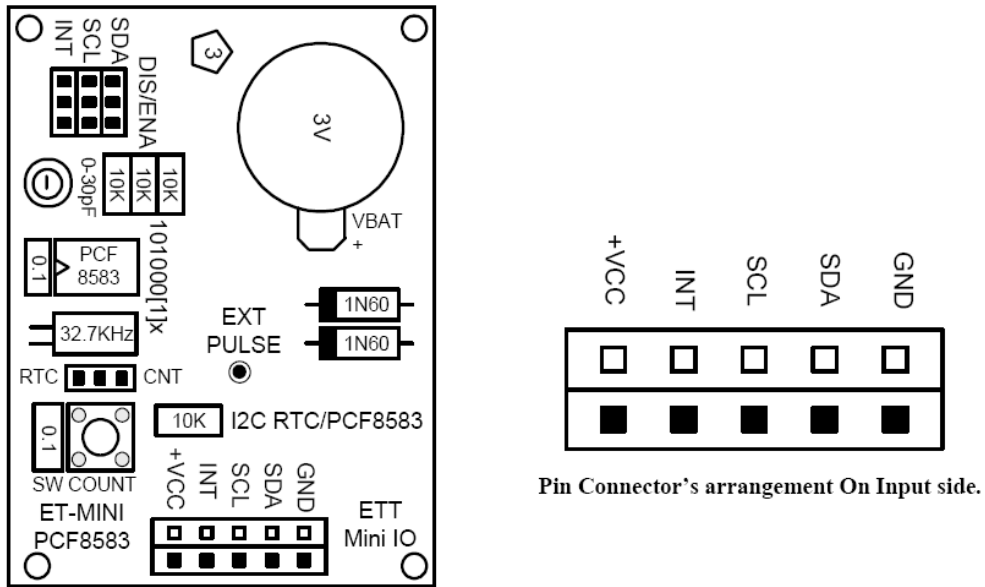

FIG 5: MR-MINI-RTC Board Layout

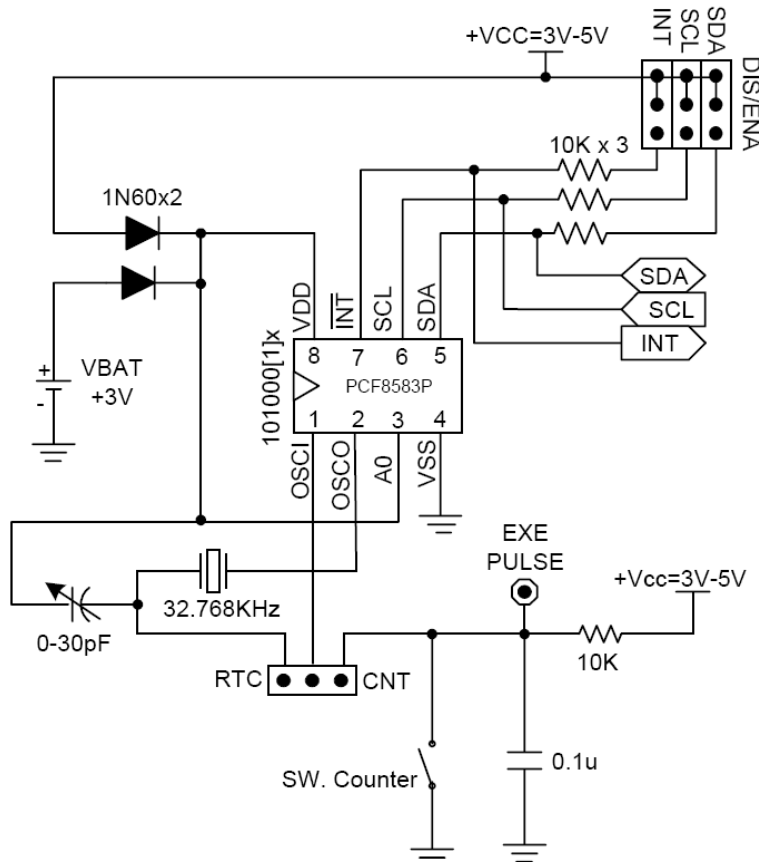

FIG 6: MR-MINI-RTC Schematic

# MR-MINI-RTC™ I<sup>2</sup>C Real Time Clock Board User Manual

## Notes

## Contact Us

We maintain a website where you can get information on our products, obtain literature and download support files. Visit us online at:

**[WWW.GRAVITECH.US](http://WWW.GRAVITECH.US)**

Use our online Forum or e-mail your technical support questions to [support@gravitech.us](mailto:support@gravitech.us). We try to respond to your questions the same day.

For sales questions or to place and order, direct your e-mails to [sales@gravitech.us](mailto:sales@gravitech.us). Refer to our website for product pricing, shipping rates, payment instructions, and for other info we need to complete your order.

**Disclaimer: MicroResearch reserves the right to modify its products or literature, or to discontinue any product at any time without prior notice. The customer is responsible for determining the suitability of any device for any application developed using MicroResearch components.**

**Copyright © 2007 MicroResearch**  
GRAVITECH GROUP      WWW.GRAVITECH.US

## Данный компонент на территории Российской Федерации

### Вы можете приобрести в компании MosChip.

Для оперативного оформления запроса Вам необходимо перейти по данной ссылке:

<http://moschip.ru/get-element>

Вы можете разместить у нас заказ для любого Вашего проекта, будь то серийное производство или разработка единичного прибора.

В нашем ассортименте представлены ведущие мировые производители активных и пассивных электронных компонентов.

Нашей специализацией является поставка электронной компонентной базы двойного назначения, продукции таких производителей как XILINX, Intel (ex.ALTERA), Vicor, Microchip, Texas Instruments, Analog Devices, Mini-Circuits, Amphenol, Glenair.

Сотрудничество с глобальными дистрибьюторами электронных компонентов, предоставляет возможность заказывать и получать с международных складов практически любой перечень компонентов в оптимальные для Вас сроки.

На всех этапах разработки и производства наши партнеры могут получить квалифицированную поддержку опытных инженеров.

Система менеджмента качества компании отвечает требованиям в соответствии с ГОСТ Р ИСО 9001, ГОСТ РВ 0015-002 и ЭС РД 009

### Офис по работе с юридическими лицами:

105318, г.Москва, ул.Щербаковская д.3, офис 1107, 1118, ДЦ «Щербаковский»

Телефон: +7 495 668-12-70 (многоканальный)

Факс: +7 495 668-12-70 (доб.304)

E-mail: [info@moschip.ru](mailto:info@moschip.ru)

Skype отдела продаж:

moschip.ru

moschip.ru\_4

moschip.ru\_6

moschip.ru\_9