

- **Excellent Size-to-Performance Ratio**
- **Hermetic 13.3 X 6.5 mm Surface-Mount Case**
- **Complies with Directive 2002/95/EC (RoHS)**

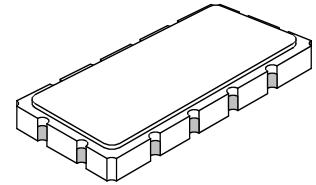

SF2140A-1

**140.0 MHz
SAW Filter**



SMP-53

Absolute Maximum Ratings

Rating	Value	Units
Input Power Level	+10	dBm
Storage Temperature Range	-40 to +85	°C
Operating Temperature Range	-30 to +80	°C
Suitable for Lead-free Soldering - Maximum Soldering Profile	260 °C for 30 s	

Electrical Characteristics

Characteristic	Sym	Notes	Min	Typ	Max	Units
Nominal Center Frequency	f_C	1		140.0		MHz
Maximum Insertion Loss at f_C	IL			10.3	11.0	dB
1 dB Bandwidth			18.4	20.8		MHz
3 dB Bandwidth			19.6	21.4		MHz
35 dB Bandwidth				25.2	26.4	MHz
Passband Ripple, 130.8 to 149.2 MHz				0.8	1.0	dB
Group Delay Ripple, 130.8 to 149.2 MHz				115	160	ns
Absolute Group Delay				1.0		µs
Input VSWR, 130.8 to 149.2 MHz				1.7	2.8	dB
Output VSWR, 130.8 to 149.2 MHz				1.8	2.3	dB
Temperature Coefficient						ppm/°C
Attenuation Referenced to Insertion Loss at f_C						dB
10 to 90 MHz			35	49		
90 to 120 MHz			40	47		
120 to 126.8 MHz			35	50		
153.2 to 160 MHz			35	45		
160 to 190 MHz			40	53		
190 to 800 MHz			35	62		
Source/Load Impedance				50		ohms

Case Style	SMP-53 13.3 X 6.5 mm Nominal Footprint
Lid Symbolization (YY=year, WW=week) See note 4	RFM SF2140A-1 YYWWS##



CAUTION: Electrostatic Sensitive Device. Observe precautions for handling.

NOTES:

1. Unless noted otherwise, all specifications apply over the operating temperature range with filter soldered to the specified demonstration board with impedance matching to 50 Ω and measured with 50 Ω network analyzer.
2. Unless noted otherwise, all frequency specifications are referenced to the nominal center frequency, f_C .
3. Rejection is measured as attenuation below the minimum IL point in the passband. Rejection in final user application is dependent on PCB layout and external impedance matching design. See Application Note No. 42 for details.
4. "LRIP" or "L" after the part number indicates "low rate initial production" and "ENG" or "E" indicates "engineering prototypes."
5. The design, manufacturing process, and specifications of this filter are subject to change.
6. Either Port 1 or Port 2 may be used for either input or output in the design. However, impedances and impedance matching may vary between Port 1 and Port 2, so that the filter must always be installed in one direction per the circuit design.
7. US and international patents may apply.
8. Murata, stylized Murata logo, and Murata N.A., Inc. are registered trademarks of Murata Manufacturing Co., Ltd.

SF2140A-1 S₂₁ Amplitude Response

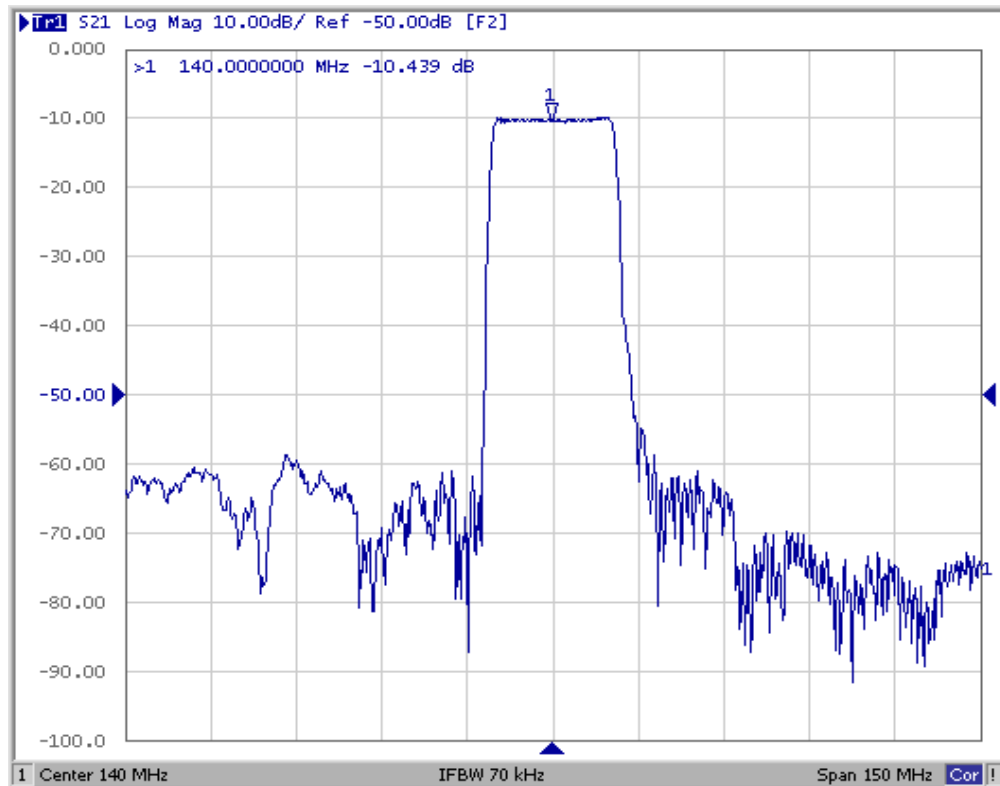

SF2140A-1 Pass-band Amplitude and Group Delay Ripple

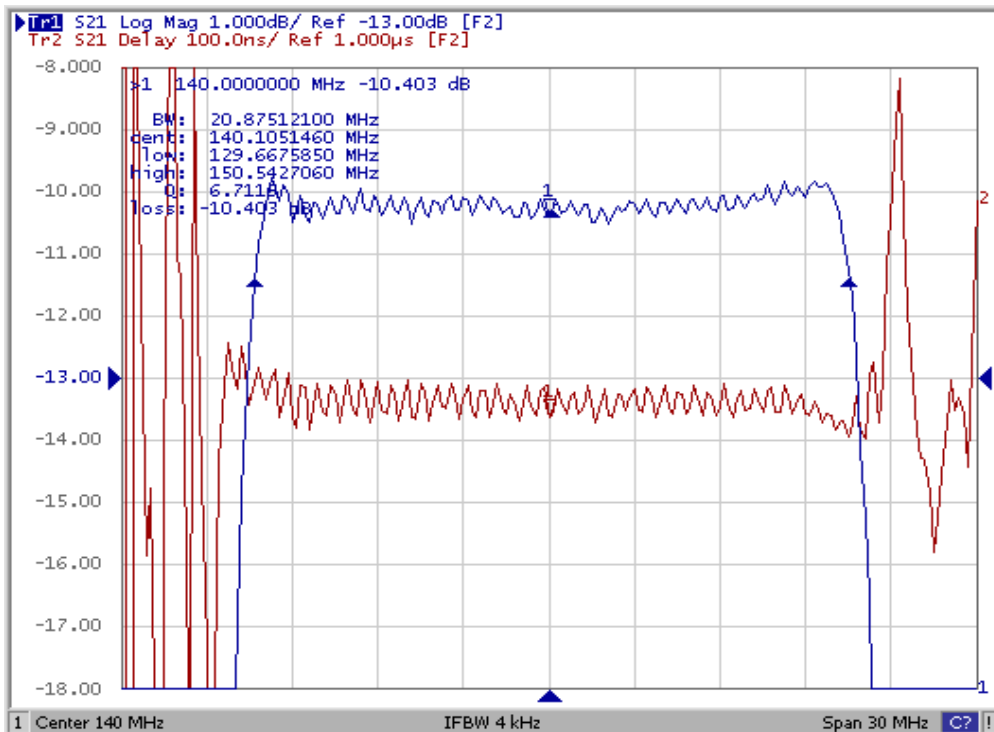

SF2140A-1 S_{11} Impedance Plot through Matching Network

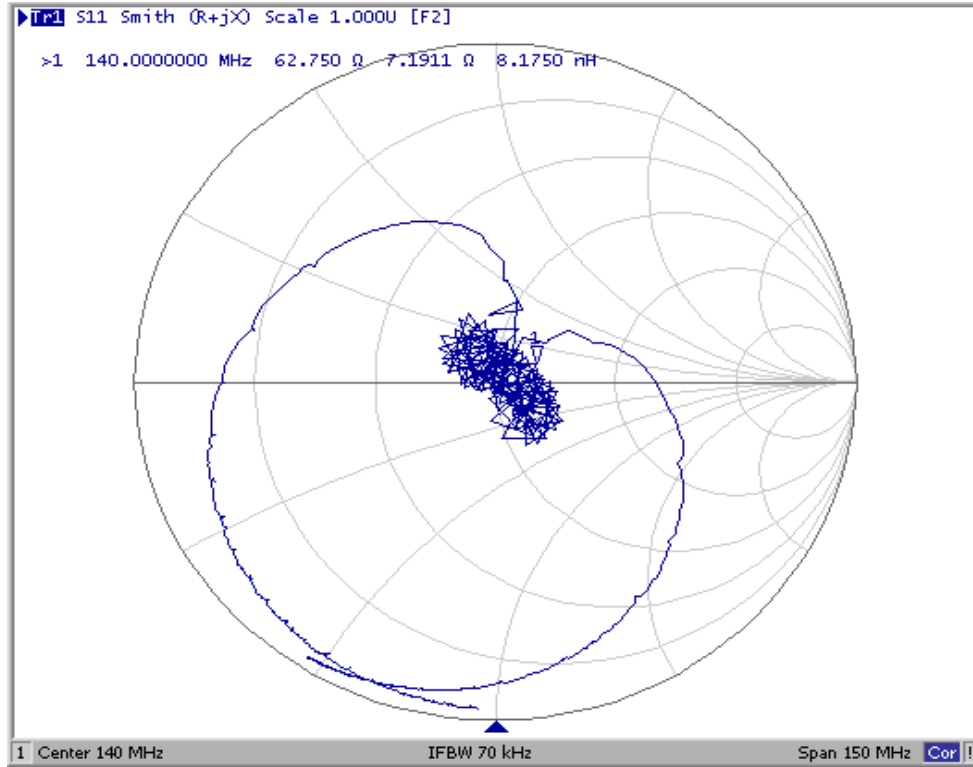

SF2140A-1 S_{22} Impedance Plot through Matching Network

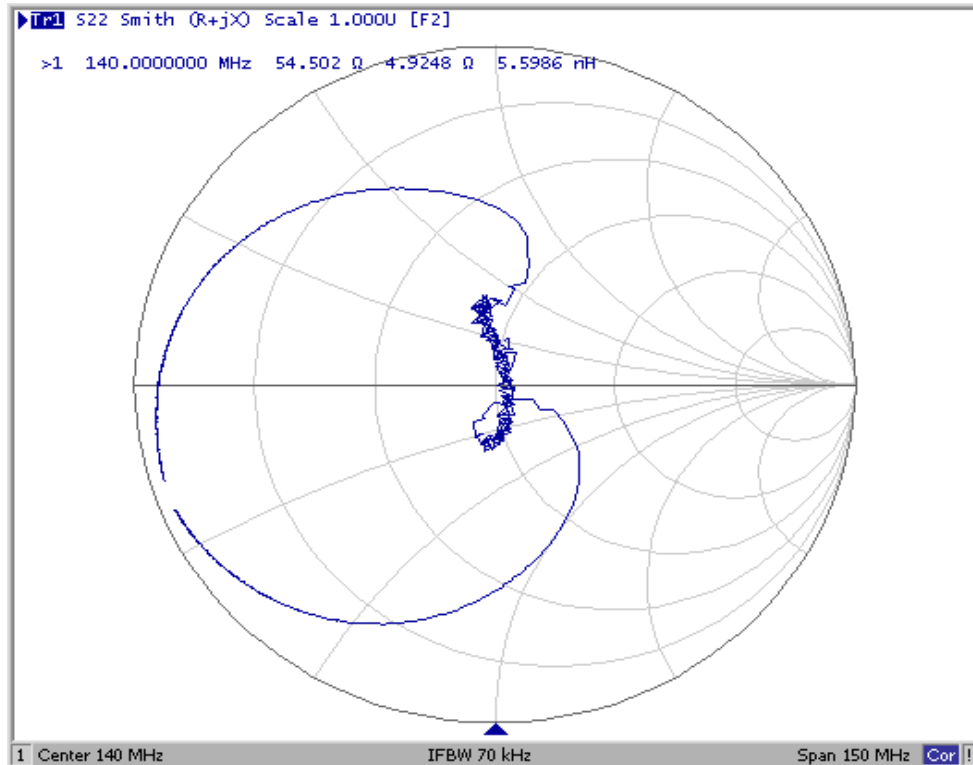

SF2140A-1 50 ohm Matching Network

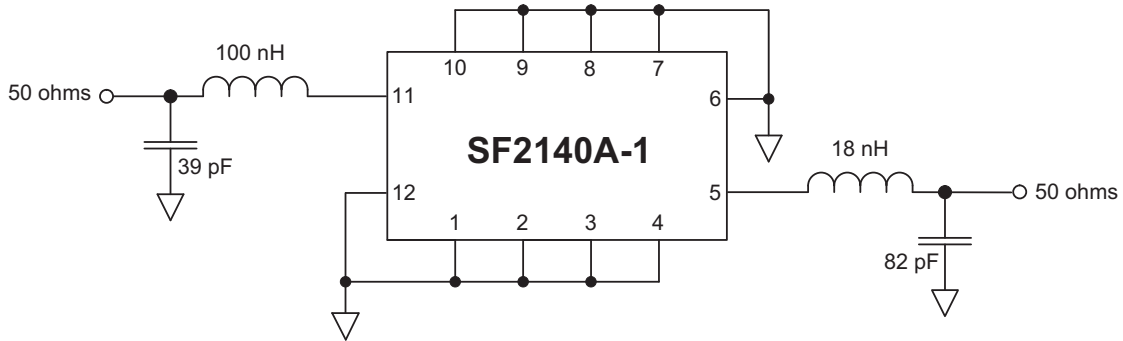

SF2140A-1 Circuit Board Pad Layout

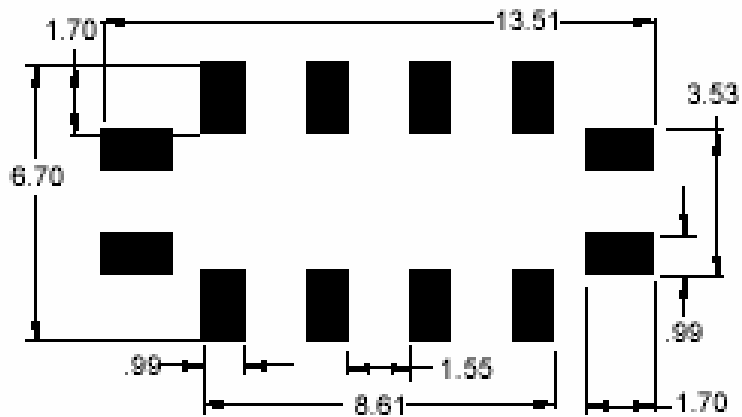

12-Terminal Ceramic Surface-Mount Case 13.3 x 6.5 mm Nominal Footprint

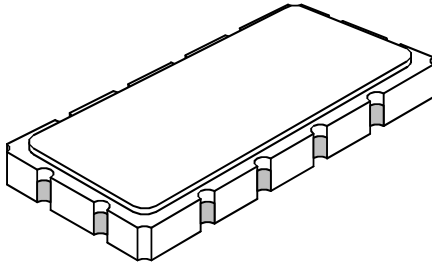

Case Dimensions						
Dimension	mm			Inches		
	Min	Nom	Max	Min	Nom	Max
A	13.08	13.31	13.60	0.515	0.524	0.535
B	6.27	6.50	6.80	0.247	0.256	0.268
C		1.91	2.00		0.075	0.079
D		1.50			0.059	
E		0.79			0.031	
H		1.0			0.039	
P		2.54			0.100	

Electrical Connections		
Connection		Terminals
Port 1	RF Input	11
	RF Input Ground	12
Port 2	RF Output	5
	RF Output Ground	6
Ground		All others

Materials	
Solder Pad Plating	0.3 to 1.0 μm Gold over 1.27 to 8.89 μm Nickel
Lid Plating	2.0 to 3.0 μm Nickel
Body	Al_2O_3 Ceramic
Pb Free	

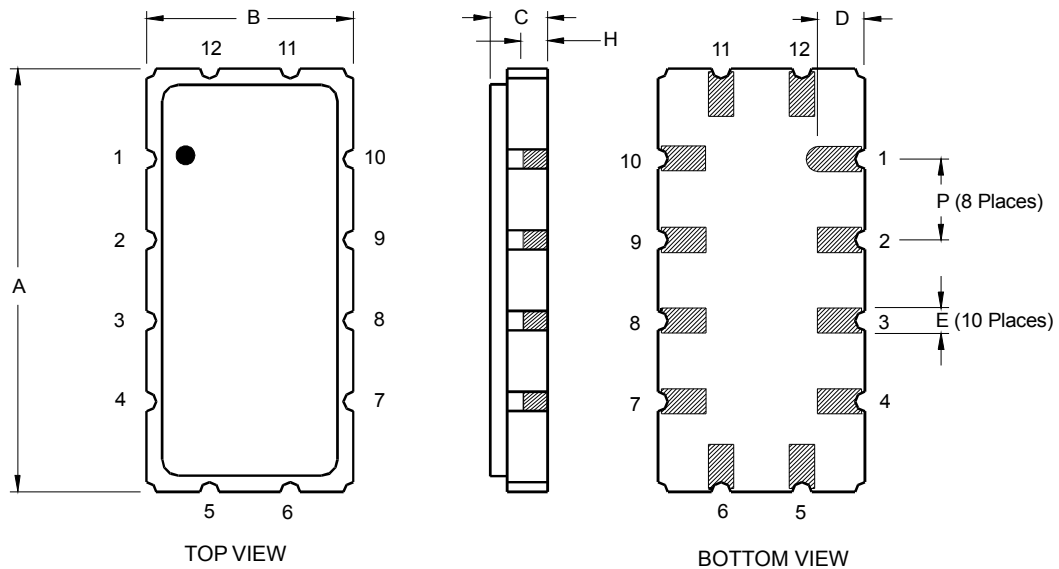

Tape and Reel Specifications

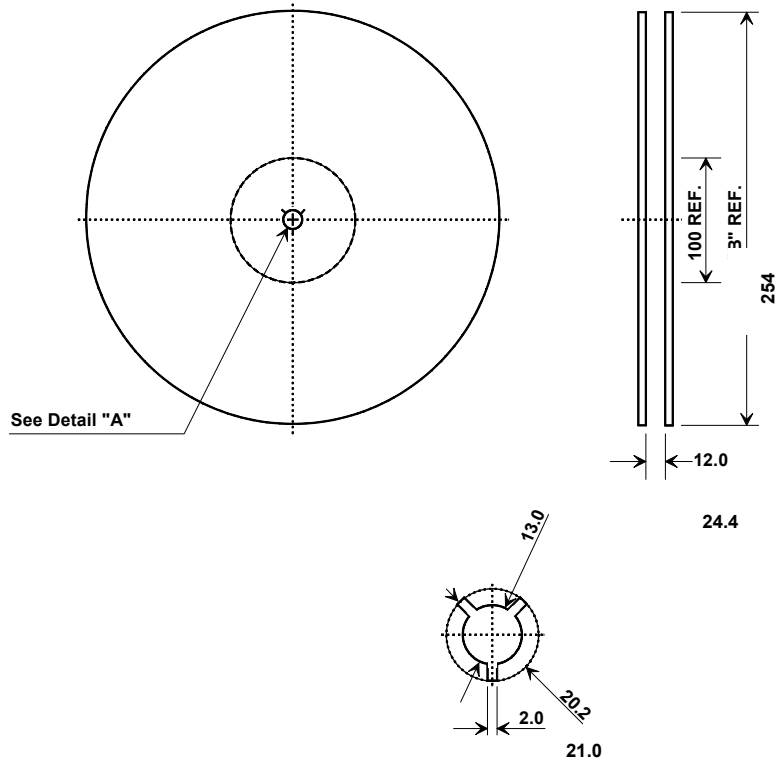

Quantity Per Reel
100 Min
1000 Max

COMPONENT ORIENTATION and DIMENSIONS

Carrier Tape Dimensions	
Ao	7.0 mm
Bo	13.8 mm
Ko	2.0 mm
Pitch	12.0 mm
W	24.0 mm

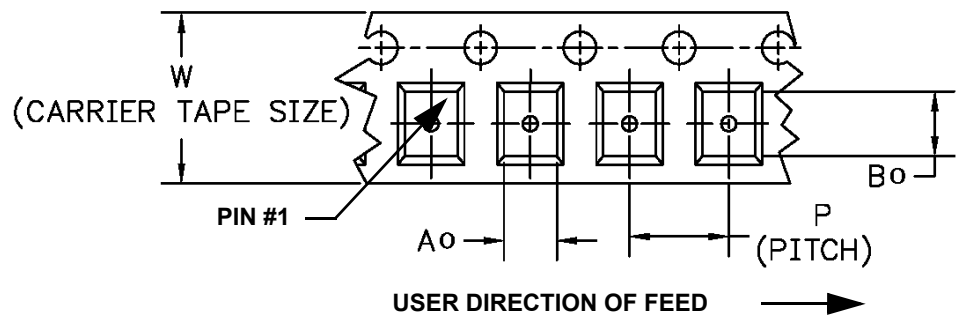
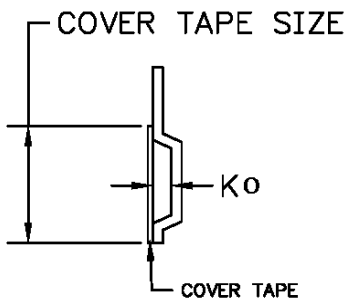

Данный компонент на территории Российской Федерации

Вы можете приобрести в компании MosChip.

Для оперативного оформления запроса Вам необходимо перейти по данной ссылке:

<http://moschip.ru/get-element>

Вы можете разместить у нас заказ для любого Вашего проекта, будь то серийное производство или разработка единичного прибора.

В нашем ассортименте представлены ведущие мировые производители активных и пассивных электронных компонентов.

Нашей специализацией является поставка электронной компонентной базы двойного назначения, продукции таких производителей как XILINX, Intel (ex.ALTERA), Vicor, Microchip, Texas Instruments, Analog Devices, Mini-Circuits, Amphenol, Glenair.

Сотрудничество с глобальными дистрибьюторами электронных компонентов, предоставляет возможность заказывать и получать с международных складов практически любой перечень компонентов в оптимальные для Вас сроки.

На всех этапах разработки и производства наши партнеры могут получить квалифицированную поддержку опытных инженеров.

Система менеджмента качества компании отвечает требованиям в соответствии с ГОСТ Р ИСО 9001, ГОСТ РВ 0015-002 и ЭС РД 009

Офис по работе с юридическими лицами:

105318, г.Москва, ул.Щербаковская д.3, офис 1107, 1118, ДЦ «Щербаковский»

Телефон: +7 495 668-12-70 (многоканальный)

Факс: +7 495 668-12-70 (доб.304)

E-mail: info@moschip.ru

Skype отдела продаж:

moschip.ru

moschip.ru_4

moschip.ru_6

moschip.ru_9