

Installation Instructions for the SR2 Series Hall-Effect Position Sensors

ISSUE 2

PK 88581

ELECTRICAL AND MAGNETIC SPECIFICATIONS

		SR2C-B4
Supply Voltage, VDC		4.5 to 24
Supply Current, mA max.		10
Output Type		NPN
Output Voltage, max.		0.40 V
Output Current, mA max.		40
Magnetic Type*		Unipolar
-40 to 100°C	Max. Op.	220
	Min. Rel.	50
	Min. Diff.	8
+25°C	Typ. Op.	150
	Typ. Rel.	80
	Typ. Diff.	10

* A unipolar sensor has a plus maximum operate point and a plus minimum release point. One magnetic pole (south) is required to operate and release a unipolar sensor.

ABSOLUTE MAXIMUM RATINGS*

Parameters	4.5 to 24 VDC Circuit
Supply Voltage (Vs)	-1.0 to +25 VDC
Voltage Externally Applied to Output	-0.5 V max. (ON or OFF) +25 V max. (OFF only)
Output Current	40 mA
Temperature, Operate and Storage	-40 to +100°C (-40 to +212°F)
Magnetic Flux	No limit. Circuit cannot be damaged by magnetic overdrive.

* Absolute maximum ratings are the extreme limits that the device will withstand without damage to the device. However, the electrical and magnetic characteristics are not guaranteed as the maximum limits (above recommended operating conditions) are approached, nor will the device necessarily operate at absolute maximum rating.

LEADWIRE COLOR CODE

Red	Vs (+)
Black	Ground (-)
White	Output (Digital)

NOTICE

Do not reverse supply voltage polarity.

Do not exceed maximum ratings.

MOUNTING DIMENSIONS (for reference only)

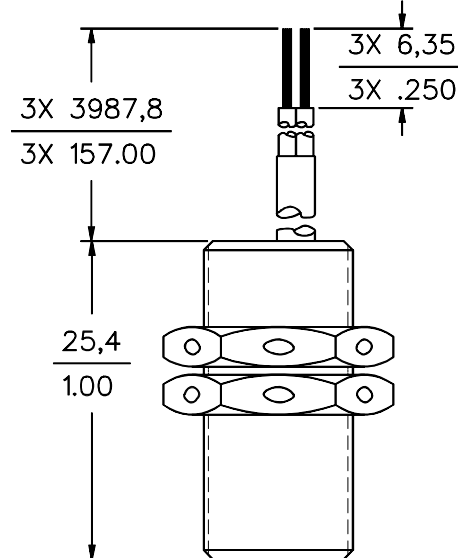

1SR15 Mounting Bracket

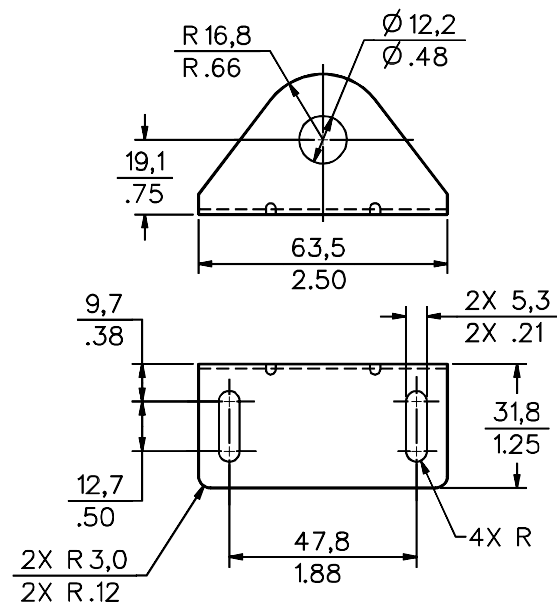

TROUBLESHOOTING

If sensor does not operate, follow these steps:

1. Make certain wiring is correct (load must be connected).
2. Measure supply voltage across the Red (+) and Black (-) leads to verify that proper supply voltage is present.
3. Connect positive lead of voltmeter to White (output) lead, and negative voltmeter lead to Black (-) lead. With magnet removed (or north pole present), the reading should equal V_s .
4. When the magnet (south pole) moves toward sensor face (beyond operating point), the sensor output should be 0.40 VDC.

WARRANTY/REMEDY

Honeywell warrants goods of its manufacture as being free of defective materials and faulty workmanship. Commencing with date of shipment, Honeywell's warranty runs for 18 months. If warranted goods are returned to Honeywell during that period of coverage, Honeywell will repair or replace without charge those items it finds defective. The foregoing is Buyer's sole remedy and is **in lieu of all other warranties, expressed or implied, including those of merchantability and fitness for a particular purpose.**

For application assistance, current specifications, pricing or name of the nearest Authorized Distributor, contact a nearby sales office. Or call:

1-800-537-6945 USA

1-416-293-8111 Canada

1-815-235-6847 International

<http://www.honeywell.sensing.com>

info.sc@honeywell.com

Specifications not affecting form, fit or function may change without notice. The information we supply is believed to be accurate and reliable as of this printing. However, we assume no responsibility for its use.

While we provide application assistance, personally and through our literature, it is up to the customer to determine the suitability of the product in the application.

CURRENT SINKING OUTPUTS

(Current flow through load into sensor.) Output terminal is open collector. In the unoperated condition ($I_L = 0$), the output voltage is normally high.

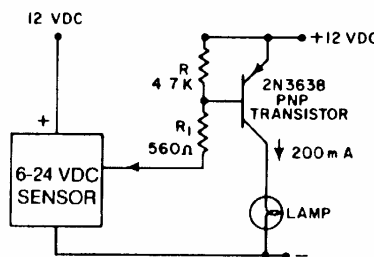
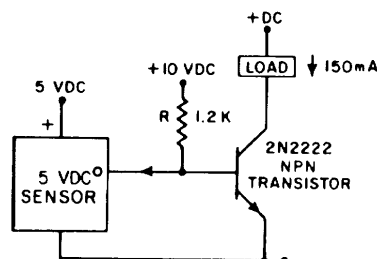
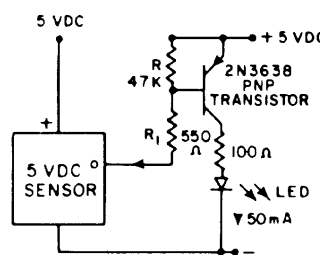
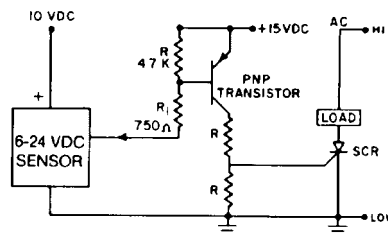

Honeywell

Sensing and Control

Honeywell

11 West Spring Street

Freeport, Illinois 61032



Printed with Soy Ink
on 50% Recycled Paper

PK 88581-2 0303 Printed in USA

www.honeywell.com/sensing

Данный компонент на территории Российской Федерации

Вы можете приобрести в компании MosChip.

Для оперативного оформления запроса Вам необходимо перейти по данной ссылке:

<http://moschip.ru/get-element>

Вы можете разместить у нас заказ для любого Вашего проекта, будь то серийное производство или разработка единичного прибора.

В нашем ассортименте представлены ведущие мировые производители активных и пассивных электронных компонентов.

Нашей специализацией является поставка электронной компонентной базы двойного назначения, продукции таких производителей как XILINX, Intel (ex.ALTERA), Vicor, Microchip, Texas Instruments, Analog Devices, Mini-Circuits, Amphenol, Glenair.

Сотрудничество с глобальными дистрибьюторами электронных компонентов, предоставляет возможность заказывать и получать с международных складов практически любой перечень компонентов в оптимальные для Вас сроки.

На всех этапах разработки и производства наши партнеры могут получить квалифицированную поддержку опытных инженеров.

Система менеджмента качества компании отвечает требованиям в соответствии с ГОСТ Р ИСО 9001, ГОСТ РВ 0015-002 и ЭС РД 009

Офис по работе с юридическими лицами:

105318, г.Москва, ул.Щербаковская д.3, офис 1107, 1118, ДЦ «Щербаковский»

Телефон: +7 495 668-12-70 (многоканальный)

Факс: +7 495 668-12-70 (доб.304)

E-mail: info@moschip.ru

Skype отдела продаж:

moschip.ru

moschip.ru_4

moschip.ru_6

moschip.ru_9