

## CUSTOMER DRAWING

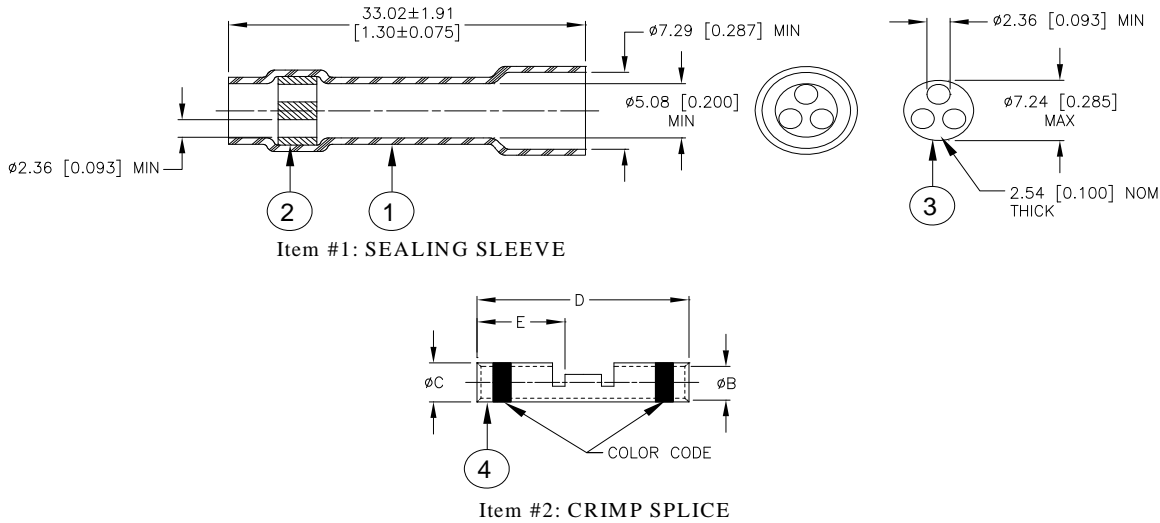

### MATERIALS

1. INSULATION SLEEVE: Heat-shrinkable, transparent blue, radiation cross-linked modified polyvinylidene flouride.
2. INTEGRAL MULTI-WIRE SEAL: Low outgassing immersion resistant thermoplastic fluoroelastomer.  
Color: BLUE.
3. SEPARATE MULTI-WIRE SEAL: Low outgassing immersion resistant thermoplastic fluoroelastomer.  
Color: BLUE.
4. CRIMP SPLICE: Base Metal: Copper Alloy 101 or 102 per ASTM B-75.  
Plating: Nickel per SAE AMS-QQ-N-290.  
Color Code: See table below.

#### Dimensions:

Part Name	Crimp Splice					Color Code
	$\phi B$	$\phi C$	D	E		
D-436-88	<u>1.27</u> [0.050]	<u>2.03</u> [0.080]	<u>12.95</u> [0.510]	<u>6.22</u> [0.245]	Red	
	1.14 [0.045]	1.91 [0.075]	12.45 [0.490]	5.72 [0.225]		
D-436-89	<u>1.75</u> [0.069]	<u>2.70</u> [0.106]	<u>14.86</u> [0.585]	<u>7.11</u> [0.280]	Blue	
	1.63 [0.064]	2.57 [0.101]	14.35 [0.565]	6.60 [0.260]		
D-436-90	<u>2.60</u> [0.102]	<u>3.91</u> [0.154]	<u>14.86</u> [0.585]	<u>7.11</u> [0.280]	Yellow	
	2.46 [0.097]	3.73 [0.147]	14.35 [0.565]	6.60 [0.260]		

		<i>Raychem</i> Devices	TITLE: <b>IN-LINE SPLICE SEALING SYSTEM, MULTI-WIRE SPLICER NICKEL PLATED, COLOR CODED, WITH INSPECTION SLOTS</b>			
Unless otherwise specified dimensions are in millimeters. [Inches dimensions are shown in brackets]			DOCUMENT NO.: <b>D-436-88/-90</b>			
TOLERANCES: 0.00 N/A 0.0 N/A 0 N/A	ANGLES: N/A  ROUGHNESS IN MICRON	TE CONNECTIVITY (TE) RESERVES THE RIGHT TO CHANGE THIS DRAWING AT ANYTIME. USER SHOULD EVALUATE THE SUITABILITY OF THE PRODUCT FOR THEIR APPLICATION.		DATE: June 26, 2015	REVISION: C	
DRAWN BY: M. FORONDA	ECO APPROVED: L. RODRIGUEZ	ECO NUMBER: 15-009842		SCALE: None	SIZE: A	SHEET: 1 of 2

©2015 TE CONNECTIVITY LTD. FAMILY OF COMPANIES. ALL RIGHT RESERVED.

If this document is printed it becomes uncontrolled. Check for the latest revision.

## SPECIFICATION CONTROL DRAWING

Installation Data:

Part Name	Wire Size Range of Crimp Splice (AWG)			
	Two wires		Three wires	
	Minimum	Maximum	Minimum	Maximum
D-436-88	26	24	28	24
D-436-89	24	20	24	22
D-436-90	22	16	22	18

MIL Spec equivalent size and wire accomodation:

Part Name	MIL Spec Equivalent Size	Wire Size Range (AWG)	Wgt. Lbs/Mpc max
D-436-88	M81824/1-1	26 - 20	1.02
D-436-89	M81824/1-2	20 - 16	1.61
D-436-90	M81824/1-3	16 - 12	2.72

### APPLICATION

1. These parts are designed to provide immersion resistant in-line splices of 2 or 3 to 2 or 3 wires falling within the size range listed on sheet 1, having nickel-plated conductors and insulations rated for at least 135°C.
2. Parts are available only as an assembly of one of each Item #1 and Item #2.
3. Parts are to be installed per assembly procedure as outlined below.
4. Inside diameter and outside diameter of splice are to be measured in crimp area, 2.54 to 5.08mm [0.100 to 0.200in] from ends of part. Slight burr permitted on parted surfaces.
5. Acceptance sampling shall be in accordance with Paragraph 4.6.1 of SAE AS81824.
6. Packing and packaging shall be in accordance with Section 5, Level C, of SAE AS81824.
7. This document takes precedence over documents referenced herein.

### ASSEMBLY PROCEDURE

#### 1.0 SCOPE

This document outlines the procedure to be followed to obtain immersion resistant multiple wire butt splices using Multi-Wire In-Line Splice Sealing system D-436-88/-90.

#### 2.0 PROCEDURE

- a) Pass the wires to be attached to one barrel through the separate multi-wire seal (3). Pass the wires to be attached to the other barrel through the sealing sleeve from the three hole insert end.
- b) Strip wires 5/16" to 11/32" and crimp into splice using a Raychem AD-1377 crimp tool. Care must be taken so that the wires remain untwisted between the splice and the separate multi-wire seal (3) or the sealing sleeve cannot be positioned properly.
- c) Position the separate multi-wire seal (3) as close as possible to the splice. Hold this piece in position by squeezing the wires directly behind it, and slide the sealing sleeve over the assembly so that the separate multi-wire seal (3) is as far inside the sleeve as possible.
- d) Apply heat, using the recommended heat source, first to the separate multi-wire seal end, and then to the other. Heat should be applied until insert melts and flows axially along the wire.

#### 3.0 RECOMMENDED RAYCHEM HEATING TOOLS

<i>Heater</i>	<i>Reflector</i>	<i>Recommended setting</i>
Heat Gun CV-1981	PR52D	7.5 - 8
Steinel HL-1802E	PR52D	8 - 9

\*Unless otherwise specified, dimensions are in millimeters. [Inches dimensions are shown in rackets]

DOCUMENT NO.: <b>D-436-88/-90</b>	ECO NUMBER: 15-009842	REVISION: C	DATE: June 26, 2015	SHEET: 2 of 2
--------------------------------------	--------------------------	----------------	------------------------	------------------

©2015 TE CONNECTIVITY LTD. FAMILY OF COMPANIES. ALL RIGHT RESERVED.

If this document is printed it becomes uncontrolled. Check for the latest revision.

## Данный компонент на территории Российской Федерации

### Вы можете приобрести в компании MosChip.

Для оперативного оформления запроса Вам необходимо перейти по данной ссылке:

<http://moschip.ru/get-element>

Вы можете разместить у нас заказ для любого Вашего проекта, будь то серийное производство или разработка единичного прибора.

В нашем ассортименте представлены ведущие мировые производители активных и пассивных электронных компонентов.

Нашей специализацией является поставка электронной компонентной базы двойного назначения, продукции таких производителей как XILINX, Intel (ex.ALTERA), Vicor, Microchip, Texas Instruments, Analog Devices, Mini-Circuits, Amphenol, Glenair.

Сотрудничество с глобальными дистрибьюторами электронных компонентов, предоставляет возможность заказывать и получать с международных складов практически любой перечень компонентов в оптимальные для Вас сроки.

На всех этапах разработки и производства наши партнеры могут получить квалифицированную поддержку опытных инженеров.

Система менеджмента качества компании отвечает требованиям в соответствии с ГОСТ Р ИСО 9001, ГОСТ РВ 0015-002 и ЭС РД 009

### Офис по работе с юридическими лицами:

105318, г.Москва, ул.Щербаковская д.3, офис 1107, 1118, ДЦ «Щербаковский»

Телефон: +7 495 668-12-70 (многоканальный)

Факс: +7 495 668-12-70 (доб.304)

E-mail: [info@moschip.ru](mailto:info@moschip.ru)

Skype отдела продаж:

moschip.ru

moschip.ru\_4

moschip.ru\_6

moschip.ru\_9