

NL3S22S

USB 2.0 + Audio Switch

The NL3S22S is a double-pole/double-throw (DPDT) analog switch for routing high speed differential data and audio. The high-speed data path is compliant with High Speed USB 2.0, Full Speed USB 1.1, Low Speed USB 1.0 and any generic UART protocol. The multi-purpose audio path is capable of passing signals with negative voltages as low as 2 V below ground and features shunt resistors to reduce Pop and Click noise in the audio system.

Features

- V_{CC} Range: 2.7 V to 5.5 V
- Control Pins Compatible with 1.8 V Interfaces
- I_{CC} : 23 μ A (Typ)
- ESD Performance: 4 kV HBM
- Available in 1.4 mm x 1.8 mm UQFN10
- These Devices are Pb-Free, Halogen Free/BFR Free and are RoHS Compliant

High Speed Data Path

- Input Signal Range: 0 V to 3.7 V
- $R_{DS(on)}$: 5 Ω (Typ)
- C_{ON} : 4.5 pF (Typ)
- Data Rate: USB 2.0-Compliant – up to 480 Mbps

Audio Path

- Input Signal Range: -2.0 V to 2.0 V
- R_{DSON} : 3 Ω (Typ)
- $R_{ON(FLAT)}$: 0.002 Ω (Typ)
- THD: 0.002% ($R_L = 16 \Omega / V_{IS} = 0.4 V_{RMS}$)

Applications

- Smartphones
- Tablets
- USB 2.0 Hosts/Peripherals
- Audio / High-Speeds Data Switching



ON Semiconductor®

www.onsemi.com

MARKING DIAGRAM

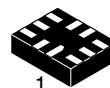

UQFN10
CASE 488AT

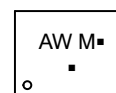

AW = Device Code
M = Date Code
▪ = Pb-Free Device

(Note: Microdot may be in either location)

ORDERING INFORMATION

Device	Package	Shipping†
NL3S22SMUTAG	UQFN10 (Pb-Free)	3000 / Tape & Reel

†For information on tape and reel specifications, including part orientation and tape sizes, please refer to our Tape and Reel Packaging Specification Brochure, BRD8011/D.

NL3S22S

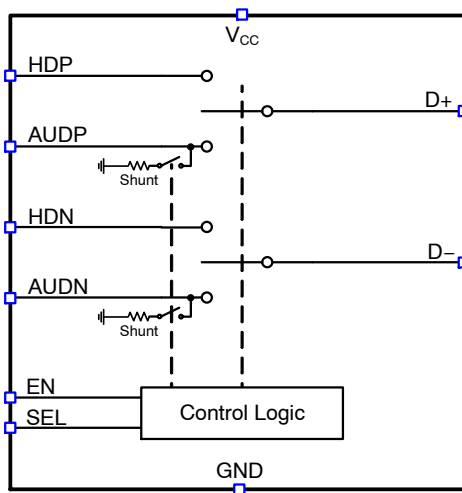

Figure 1. Block Diagram

FUNCTION TABLE

EN	SEL	Shunt Status	D+/D- Function
0	X	ON	No Connect
1	0	OFF	AUDP/AUDN
1	1	ON	HDP/HDN

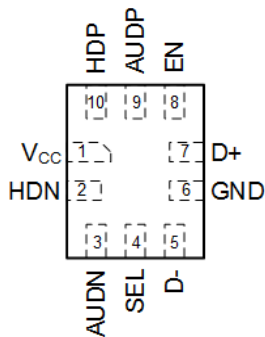

Figure 2. UQFN10 – Top Through View

PIN DESCRIPTION

Pin Name	Pin	Description
V _{CC}	1	Power Supply
HDN	2	High Speed Differential Data (-)
AUDN	3	Audio Signal (-)
SEL	4	Function Select
D-	5	Audio/Data Common I/O (-)
GND	6	Ground
D+	7	Audio/Data Common I/O (+)
EN	8	Chip Enable
AUDP	9	Audio Signal (+)
HDP	10	High Speed Differential Data (+)

NL3S22S

MAXIMUM RATINGS

Rating	Symbol	Value	Unit
V_{CC}	Positive DC Supply Voltage	-0.3 to +6	V
V_{IS}	Analog Input/Output Voltage	HDP, HDN	-0.3 to +5.5
		AUDP, AUDN	-2.5 to $V_{CC} + 0.3$
		D+, D-	-2.5 to +5.5
V_{IN}	Digital Control Pin Voltage on EN, SEL	-0.3 to $V_{CC} + 0.3$	V
T_s	Storage Temperature	-55 to +150	°C
T_L	Lead Temperature, 1 mm from Case for 10 seconds	260	°C
T_J	Junction Temperature Under Bias	150	°C
MSL	Moisture Sensitivity (Note 1)	Level 1	
I_{LU}	Latchup Current (Note 2)	±100	mA
ESD	ESD Protection (Note 3)	Human Body Model	4000

Stresses exceeding those listed in the Maximum Ratings table may damage the device. If any of these limits are exceeded, device functionality should not be assumed, damage may occur and reliability may be affected.

1. Moisture Sensitivity Level (MSL): 1 per IPC/JEDEC standard: J-STD-020A.
2. Latch up Current Maximum Rating: ±100 mA per JEDEC standard: JESD78.
3. This device series contains ESD protection and passes the following tests:
Human Body Model (HBM) ±4.0 kV per JEDEC standard: JESD22-A114 for all pins.

RECOMMENDED OPERATING CONDITIONS

Symbol	Parameter	Min	Max	Unit
V_{CCEN}	Positive DC Supply Voltage	2.7	5.5	V
V_{IS}	Switch Input / Output Voltage (Note 4)	HDP, HDN	0	3.7
		AUDP, AUDN	-2.0	2.0
		D+, D-	-2.0	3.7
V_{IN}	Digital Control Input Voltage	GND	V_{CC}	V
T_A	Operating Temperature Range	-40	+85	°C

4. If the audio channel is not in use, it is recommended that no signals are applied on the audio inputs AUDN and AUDP.

NL3S22S

DC ELECTRICAL CHARACTERISTICS (Typical values are at $V_{CC} = +3.6\text{ V}$ and $T_A = +25\text{ }^\circ\text{C}$)

Symbol	Parameter	Test Conditions	V_{CC} (V)	-40 °C to 85 °C			Unit
				Min	Typ	Max	

POWER SUPPLY

I_{CC}	Supply Current	$I_{IS} = 0\text{ mA}$	4.2	-	23	105	μA
----------	----------------	------------------------	-----	---	----	-----	---------------

Control Logic (EN, SEL)

V_{IH}	Input High Voltage		4.2	1.5	-	-	V
			3.6	1.4	-	-	
			2.7	1.3	-	-	
V_{IL}	Input Low Voltage		4.2	-	-	0.4	V
			3.6	-	-	0.4	
			2.7	-	-	0.4	
V_{IHYS}	Input Hysteresis		2.7 – 5.5	-	250	-	mV
I_{IN}	Leakage Current		2.7 – 5.5	-	-	± 150	nA

AUDIO SWITCH (AUDP/AUDN ↔ D+/D-)

R_{ON}	ON-Resistance	$V_{IS} = -2.0\text{ V to } 2.0\text{ V}, I_{IS} = 50\text{ mA}$	3.0	-	3	5	Ω
ΔR_{ON}	ON-Resistance Matching Between Channels	$V_{IS} = -2.0\text{ V to } 2.0\text{ V}, I_{IS} = 50\text{ mA}$	3.0	-	0.05	-	Ω
$R_{FLAT(ON)}$	ON Resistance Flatness	$V_{IS} = -2.0\text{ V to } 2.0\text{ V}, I_{IS} = 50\text{ mA}$	3.0	-	0.002	-	Ω
R_{SH}	Shunt Resistance		3.6	-	125	200	Ω

DATA SWITCH (HDP/HDN ↔ D+/D-)

R_{ON}	ON-Resistance	$V_{IS} = 0\text{ V to } 1.7\text{ V}, I_{IS} = 15\text{ mA}$	3.0	-	5	7.5	Ω
ΔR_{ON}	ON-Resistance Matching Between Channels	$V_{IS} = 0\text{ V to } 1.7\text{ V}, I_{IS} = 15\text{ mA}$	3.0	-	0.02	-	Ω
$R_{FLAT(ON)}$	ON Resistance Flatness	$V_{IS} = 0\text{ V to } 1.7\text{ V}, I_{IS} = 15\text{ mA}$	3.0	-	0.003	-	Ω
$I_{SW(OFF)}$	OFF-State Leakage	$V_{IS} = 0\text{ V to } 3.6$	3.6	-	-	200	nA
$I_{SW(ON)}$	ON-State Leakage	$V_{IS} = 0\text{ V to } 3.6$	3.6	-	-	± 200	nA

NL3S22S

AC ELECTRICAL CHARACTERISTICS (Typical values are at $V_{CC} = +3.6\text{ V}$ and $T_A = +25\text{ }^\circ\text{C}$)

Symbol	Parameter	Test Conditions	V_{CC} (V)	-40 °C to 85 °C			Unit
				Min	Typ	Max	

AUDIO SWITCH (AUDP/AUDN ↔ D+/D-)

THD	Audio THD	$f = 20\text{ Hz to }20\text{ kHz}$, $V_{IS} = 0.4\text{ V}_{RMS}$, DC Bias = 0 V, $R_L = 16\ \Omega$	2.7 – 5.5	–	0.002	–	%
PSRR	Power Supply Ripple Rejection	From V_{CC} unto AUDP/AUDN, $f = 217\text{ Hz}$, $R_L = 16\ \Omega$	2.7 – 5.5	–	118	–	dB

DATA SWITCH (HDP/HDN ↔ D+/D-)

C_{ON}	Equivalent ON-Capacitance	Switch ON, $f = 1\text{ MHz}$	3.6	–	4.84	–	pF
C_{OFF}	Equivalent OFF-Capacitance	Switch OFF, $f = 1\text{ MHz}$	3.6	–	2.06	–	pF
D_{IL}	Differential Insertion Loss	$f = 10\text{ MHz}$	2.7 – 5.5	–	-0.42	–	dB
		$f = 800\text{ MHz}$	2.7 – 5.5	–	-1.89	–	
		$f = 1.1\text{ GHz}$	2.7 – 5.5	–	-3.01	–	
D_{ISO}	Differential Off-Isolation	$f = 10\text{ MHz}$	2.7 – 5.5	–	-60	–	dB
		$f = 800\text{ MHz}$	2.7 – 5.5	–	-15	–	
		$f = 1.1\text{ GHz}$	2.7 – 5.5	–	-15	–	
D_{CTK}	Differential Crosstalk	$f = 10\text{ MHz}$	2.7 – 5.5	–	-67	–	dB
		$f = 800\text{ MHz}$	2.7 – 5.5	–	-23	–	
		$f = 1.1\text{ GHz}$	2.7 – 5.5	–	-19	–	
PSRR	Power Supply Ripple Rejection	From V_{CC} unto D+/D-, $f = 217\text{ Hz}$, $R_L = 50\ \Omega$	2.7 – 5.5	–	108	–	dB

DYNAMIC TIMING

t_{PD}	Propagation Delay (Notes 5 and 6)	V_{NO_n} or $V_{NC_n} = 0\text{ V}$, $R_L = 50\ \Omega$,	2.7 – 5.5	–	0.25	–	ns
t_{ON}	Turn-On Time	$V_{IS} = 1\text{ V}$, $R_L = 50\ \Omega$, $C_L = 7\text{ pF}$ (fix-ture only)	2.7 – 5.5				μs
		EN or SEL to AUDP/AUDN		–	2.2	–	
		EN or SEL to HDP/HDN		–	6.2	–	
t_{OFF}	Turn-Off Time	$V_{IS} = 1\text{ V}$, $R_L = 50\ \Omega$, $C_L = 7\text{ pF}$ (fix-ture only)	2.7 – 5.5				ns
		EN or SEL to AUDP/AUDN		–	67	–	
		EN or SEL to HDP/HDN		–	1200	–	
$t_{sk(b-b)}$	Bit to bit skew	Within the same differential channel	2.7 – 5.5	–	5	–	ps
$t_{sk(ch-ch)}$	Channel to channel skew	Maximum skew between all channels	2.7 – 5.5	–	5	–	ps

5. Guaranteed by design.

6. No other delays than the RC network formed by the load resistance and the load capacitance of the switch are added on the bus. For a 10 pF load, this delay is 5 ns which is much smaller than rise and fall time of typical driving systems. Propagation delays on the bus are determined by the driving circuit on the driving side and its interactions with the load of the driven side.

PARAMETER MEASUREMENT INFORMATION

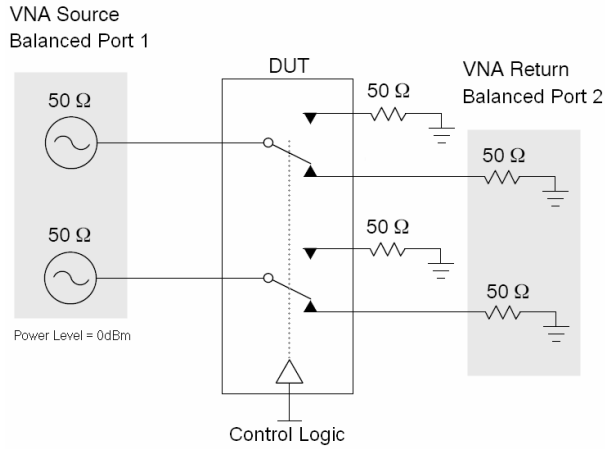

Figure 3. Differential Insertion Loss (S_{DD21})

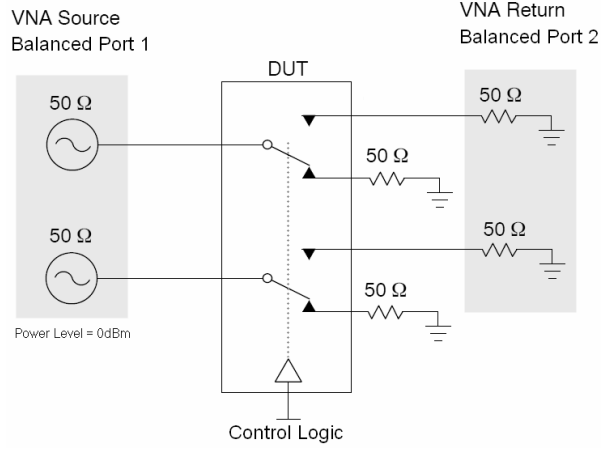

Figure 4. Differential Off Isolation (S_{DD21})

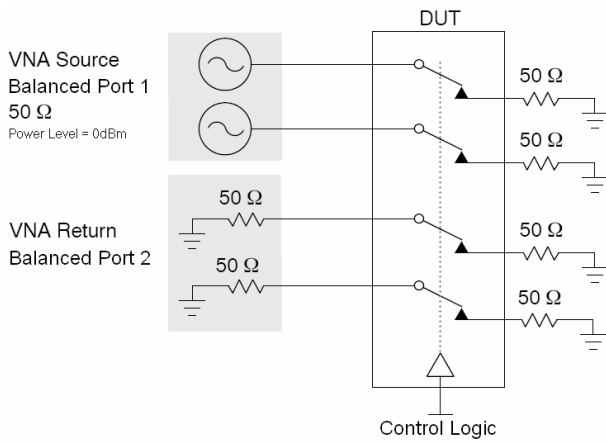
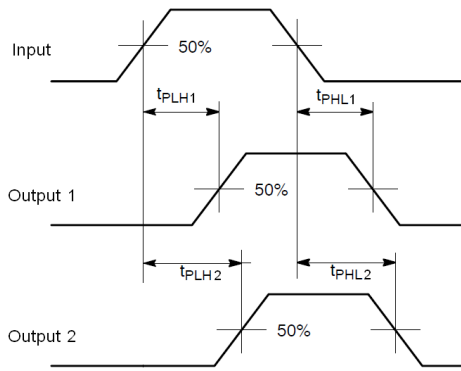

Figure 5. Differential Crosstalk (S_{DD21})



$$t_{skew} = |t_{PLH1} - t_{PLH2}| \text{ or } |t_{PHL1} - t_{PHL2}|$$

Figure 6. Bit-to-Bit and Channel-to-Channel Skew

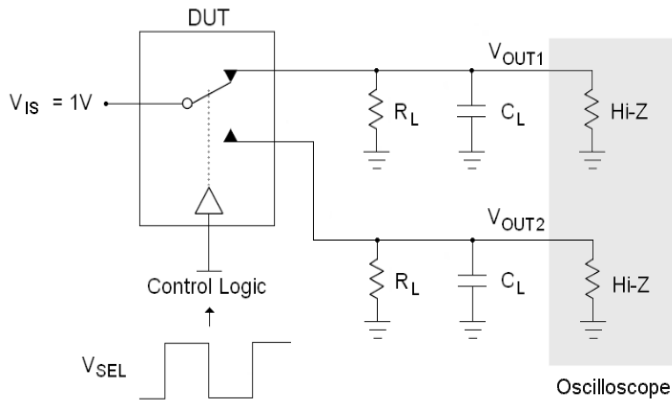

Figure 7. t_{ON} and t_{OFF}

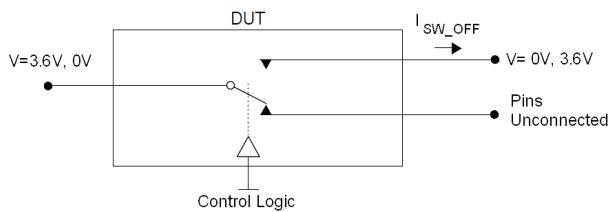
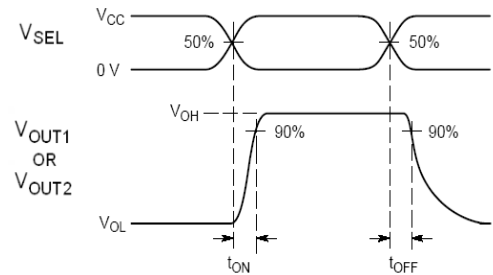

Figure 8. Off State Leakage

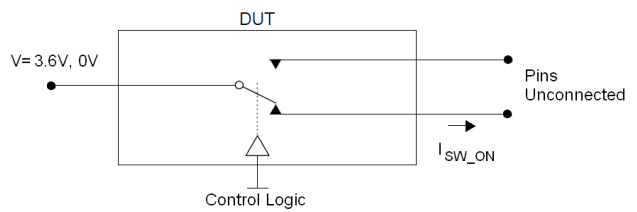

Figure 9. On State Leakage

NL3S22S

TYPICAL OPERATING CHARACTERISTICS

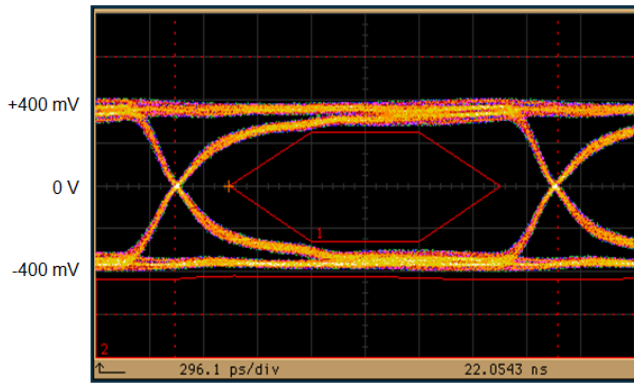

Figure 10. USB 2.0 High Speed Eye Diagram

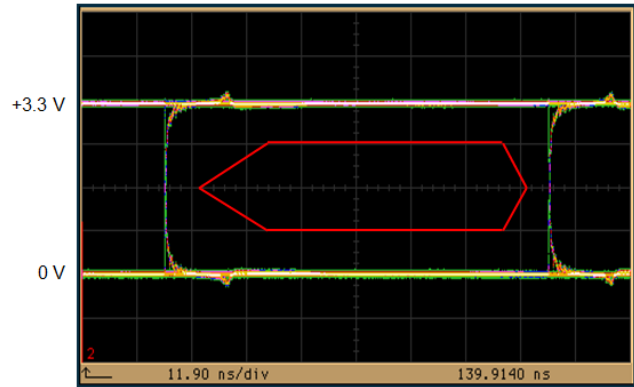

Figure 11. USB 1.1 Full Speed Eye Diagram

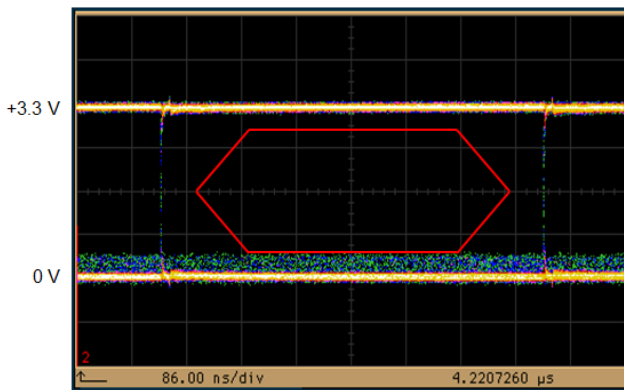

Figure 12. USB 1.0 Low Speed Eye Diagram

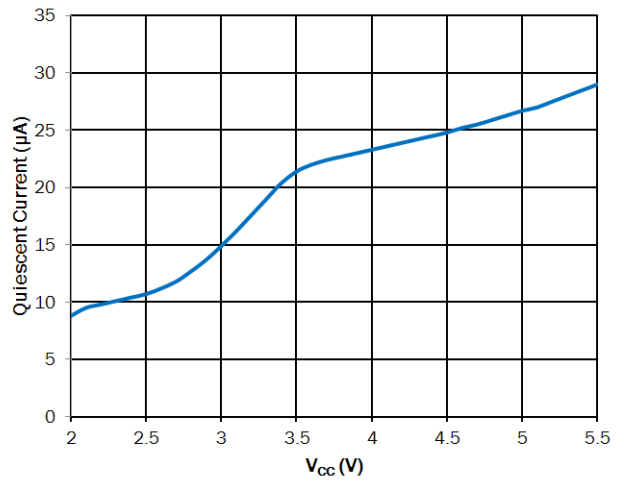

Figure 13. Product Supply Current

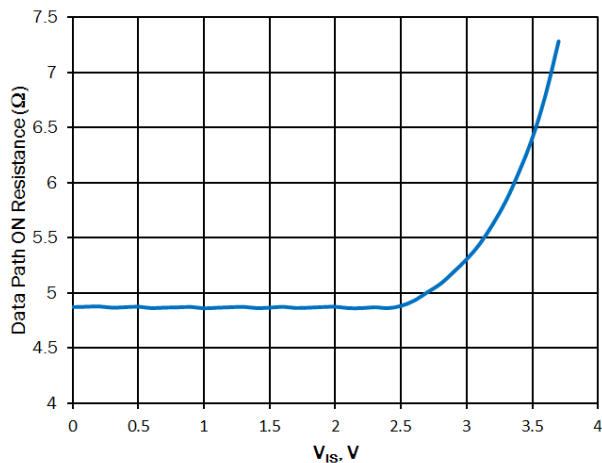

Figure 14. Data Path On Resistance

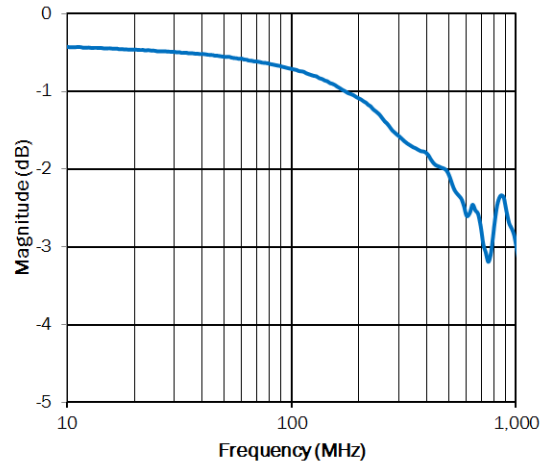

Figure 15. Data Switch Differential Insertion Loss

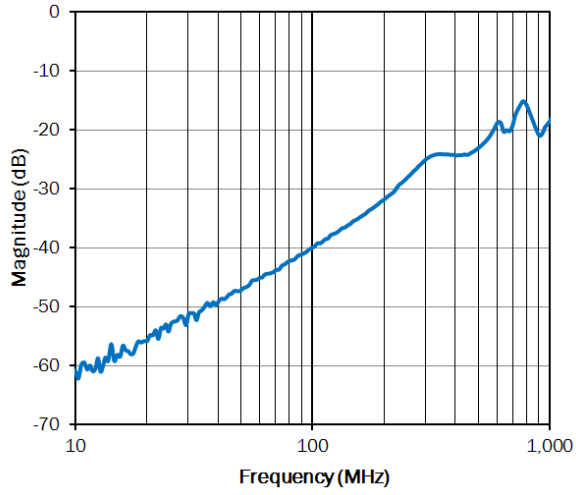

Figure 16. Data Switch Differential Off-Isolation

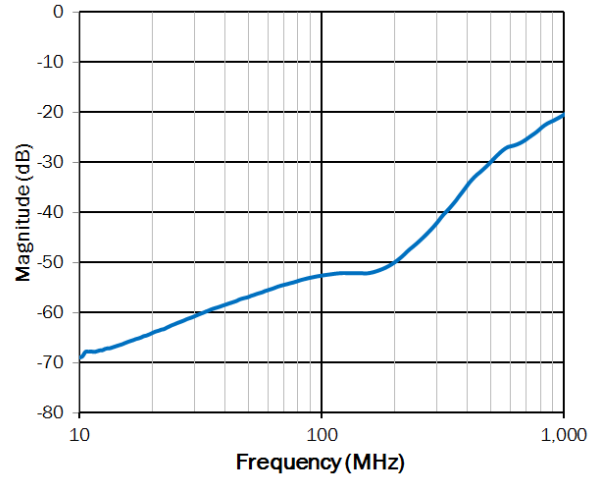

Figure 17. Data Switch Differential Crosstalk

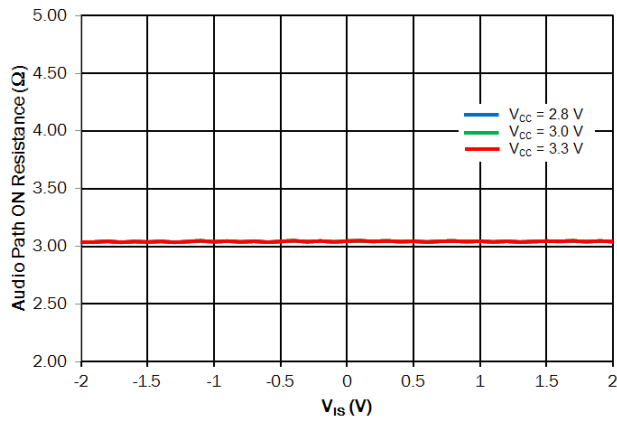

Figure 18. Audio Path On Resistance

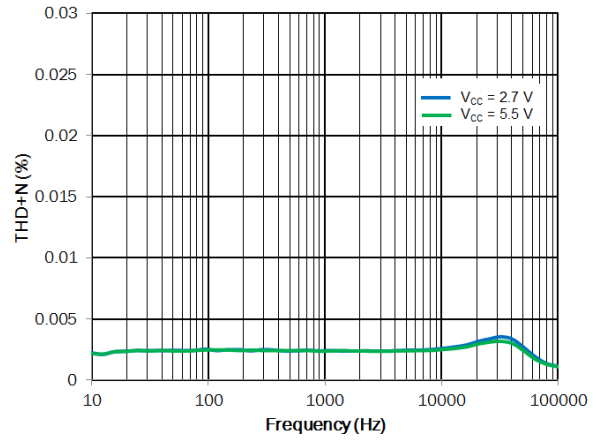
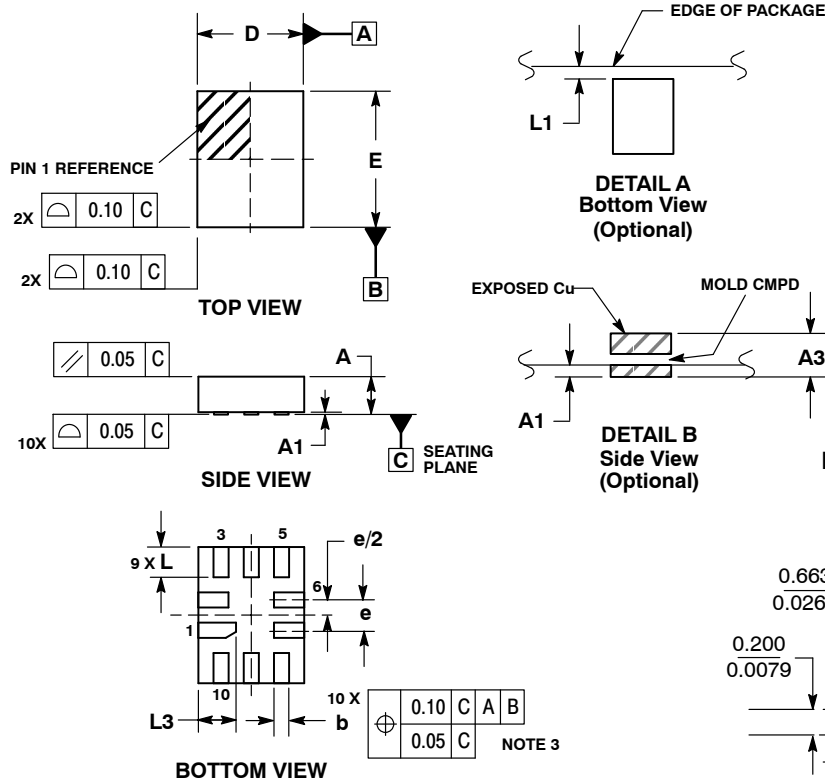

Figure 19. Audio THD

NL3S22S

PACKAGE DIMENSIONS

UQFN10 1.4x1.8, 0.4P CASE 488AT ISSUE A



NOTES:

1. DIMENSIONING AND TOLERANCING PER ASME Y14.5M, 1994.
2. CONTROLLING DIMENSION: MILLIMETERS
3. DIMENSION b APPLIES TO PLATED TERMINAL AND IS MEASURED BETWEEN 0.25 AND 0.30 MM FROM TERMINAL.
4. COPLANARITY APPLIES TO THE EXPOSED PAD AS WELL AS THE TERMINALS.

MILLIMETERS		
DIM	MIN	MAX
A	0.45	0.60
A1	0.00	0.05
A3	0.127 REF	
b	0.15	0.25
D	1.40 BSC	
E	1.80 BSC	
e	0.40 BSC	
L	0.30	0.50
L1	0.00	0.15
L3	0.40	0.60

MOUNTING FOOTPRINT*

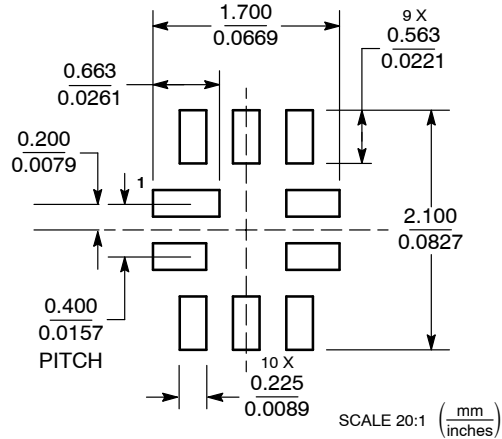

*For additional information on our Pb-Free strategy and soldering details, please download the ON Semiconductor Soldering and Mounting Techniques Reference Manual, SOLDERRM/D.

ON Semiconductor and are trademarks of Semiconductor Components Industries, LLC dba ON Semiconductor or its subsidiaries in the United States and/or other countries. ON Semiconductor owns the rights to a number of patents, trademarks, copyrights, trade secrets, and other intellectual property. A listing of ON Semiconductor's product/patent coverage may be accessed at www.onsemi.com/site/pdf/Patent-Marking.pdf. ON Semiconductor reserves the right to make changes without further notice to any products herein. ON Semiconductor makes no warranty, representation or guarantee regarding the suitability of its products for any particular purpose, nor does ON Semiconductor assume any liability arising out of the application or use of any product or circuit, and specifically disclaims any and all liability, including without limitation special, consequential or incidental damages. Buyer is responsible for its products and applications using ON Semiconductor products, including compliance with all laws, regulations and safety requirements or standards, regardless of any support or applications information provided by ON Semiconductor. "Typical" parameters which may be provided in ON Semiconductor data sheets and/or specifications can and do vary in different applications and actual performance may vary over time. All operating parameters, including "Typicals" must be validated for each customer application by customer's technical experts. ON Semiconductor does not convey any license under its patent rights nor the rights of others. ON Semiconductor products are not designed, intended, or authorized for use as a critical component in life support systems or any FDA Class 3 medical devices or medical devices with a same or similar classification in a foreign jurisdiction or any devices intended for implantation in the human body. Should Buyer purchase or use ON Semiconductor products for any such unintended or unauthorized application, Buyer shall indemnify and hold ON Semiconductor and its officers, employees, subsidiaries, affiliates, and distributors harmless against all claims, costs, damages, and expenses, and reasonable attorney fees arising out of, directly or indirectly, any claim of personal injury or death associated with such unintended or unauthorized use, even if such claim alleges that ON Semiconductor was negligent regarding the design or manufacture of the part. ON Semiconductor is an Equal Opportunity/Affirmative Action Employer. This literature is subject to all applicable copyright laws and is not for resale in any manner.

PUBLICATION ORDERING INFORMATION

LITERATURE FULFILLMENT:

Literature Distribution Center for ON Semiconductor
19521 E. 32nd Pkwy, Aurora, Colorado 80011 USA
Phone: 303-675-2175 or 800-344-3860 Toll Free USA/Canada
Fax: 303-675-2176 or 800-344-3867 Toll Free USA/Canada
Email: orderlit@onsemi.com

N. American Technical Support: 800-282-9855 Toll Free
USA/Canada
Europe, Middle East and Africa Technical Support:
Phone: 421 33 790 2910
Japan Customer Focus Center
Phone: 81-3-5817-1050

ON Semiconductor Website: www.onsemi.com

Order Literature: <http://www.onsemi.com/orderlit>

For additional information, please contact your local Sales Representative

Данный компонент на территории Российской Федерации

Вы можете приобрести в компании MosChip.

Для оперативного оформления запроса Вам необходимо перейти по данной ссылке:

<http://moschip.ru/get-element>

Вы можете разместить у нас заказ для любого Вашего проекта, будь то серийное производство или разработка единичного прибора.

В нашем ассортименте представлены ведущие мировые производители активных и пассивных электронных компонентов.

Нашей специализацией является поставка электронной компонентной базы двойного назначения, продукции таких производителей как XILINX, Intel (ex.ALTERA), Vicor, Microchip, Texas Instruments, Analog Devices, Mini-Circuits, Amphenol, Glenair.

Сотрудничество с глобальными дистрибьюторами электронных компонентов, предоставляет возможность заказывать и получать с международных складов практически любой перечень компонентов в оптимальные для Вас сроки.

На всех этапах разработки и производства наши партнеры могут получить квалифицированную поддержку опытных инженеров.

Система менеджмента качества компании отвечает требованиям в соответствии с ГОСТ Р ИСО 9001, ГОСТ РВ 0015-002 и ЭС РД 009

Офис по работе с юридическими лицами:

105318, г.Москва, ул.Щербаковская д.3, офис 1107, 1118, ДЦ «Щербаковский»

Телефон: +7 495 668-12-70 (многоканальный)

Факс: +7 495 668-12-70 (доб.304)

E-mail: info@moschip.ru

Skype отдела продаж:

moschip.ru

moschip.ru_4

moschip.ru_6

moschip.ru_9