

GaAs SPDT Switch DC - 3.0 GHz

Rev. V1

Features

- Low Insertion Loss: < 0.3 dB @ 900 MHz
- Low Power Consumption: < 15 μ A @ -2.3 Volts
- Positive or Negative 2.3 to 8 Volt Control
- Lead-Free SC-70 (SOT-363) Package
- 100% Matte Tin Plating over Copper
- Halogen-Free "Green" Mold Compound
- 260°C Reflow Compatible
- RoHS* Compliant version of SW-456

Description

M/A-COM's MASW-007221 is a GaAs monolithic switch in a lead-free SC-70 (SOT-363) surface mount plastic package. The MASW-007221 is ideally suited for applications where very low power consumption, low insertion loss, very small size, and low cost are required. Typical applications are in dual band systems where switching between small signal components is required, i.e. filter banks, single-band LNA's, converters, etc.

The MASW-007221 can be used in applications up to 0.25 watts in systems such as cellular, PCS, DCS1800, GSM, CDMA, W-CDMA and other analog / digital wireless communication systems.

The MASW-007221 is fabricated using a mature 0.5 micron PHEMT process. The process features full passivation for performance and reliability.

Ordering Information ¹

Part Number	Package
MASW-007221-000000	Bulk Packaging
MASW-007221-TR3000	3000 piece reel

1. Reference Application Note M513 for reel size information.

Functional Schematic: Positive Control Voltage

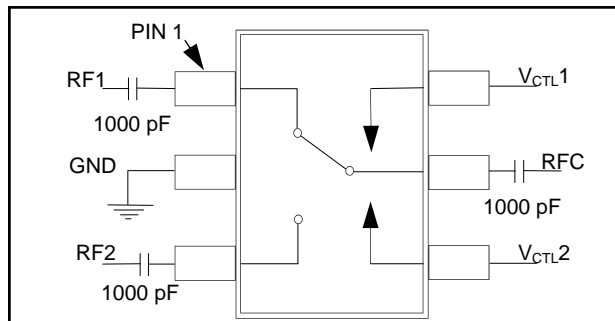

Functional Schematic: Negative Control Voltage

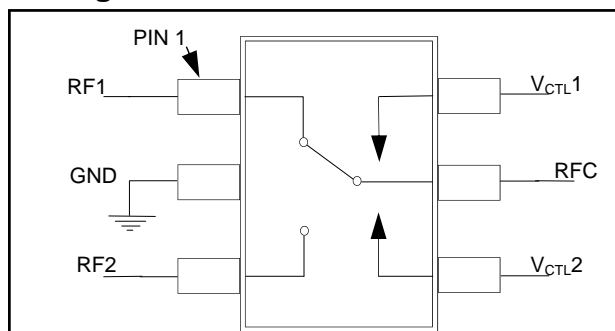

Pin Configuration

PIN	Function	Description
1	RF1	RF In/Out
2	GND	RF Ground
3	RF2	RF In/Out
4	V_CTL2	Voltage Control 2
5	RFC	RF Common
6	V_CTL1	Voltage Control 1

Absolute Maximum Ratings ^{2,3}

Parameter	Absolute Maximum
Input Power (0.5 - 3.0 GHz) 3 V Control 5 V Control	+30 dBm +33 dBm
Operating Voltage	+8.5 volts
Operating Temperature	-40°C to +85°C
Storage Temperature	-65°C to +150°C

2. Exceeding any one or combination of these limits may cause permanent damage to this device.

3. M/A-COM does not recommend sustained operation near these survivability limits.

¹ * Restrictions on Hazardous Substances, European Union Directive 2002/95/EC.

ADVANCED: Data Sheets contain information regarding a product M/A-COM Technology Solutions is considering for development. Performance is based on target specifications, simulated results, and/or prototype measurements. Commitment to develop is not guaranteed.

PRELIMINARY: Data Sheets contain information regarding a product M/A-COM Technology Solutions has under development. Performance is based on engineering tests. Specifications are typical. Mechanical outline has been fixed. Engineering samples and/or test data may be available. Commitment to produce in volume is not guaranteed.

• **North America** Tel: 800.366.2266 / Fax: 978.366.2266
 • **Europe** Tel: 44.1908.574.200 / Fax: 44.1908.574.300
 • **Asia/Pacific** Tel: 81.44.844.8296 / Fax: 81.44.844.8298
 Visit www.macomtech.com for additional data sheets and product information.

M/A-COM Technology Solutions Inc. and its affiliates reserve the right to make changes to the product(s) or information contained herein without notice.

GaAs SPDT Switch DC - 3.0 GHz

Rev. V1

Electrical Specifications: $T_A = 25^\circ\text{C}$, $V_{\text{CTL}} = 0, -2.3$ volts (unless otherwise specified), $Z_0 = 50$

Parameter	Test Conditions	Units	Min.	Typ.	Max.
Insertion Loss ⁵	DC - 1 GHz	dB	—	0.35	0.5
	1 - 2 GHz	dB	—	0.45	0.6
	2 - 3 GHz	dB	—	0.56	0.8
Isolation	DC - 1 GHz	dB	20	22	—
	1 - 2 GHz	dB	15	17	—
	2 - 3 GHz	dB	10	12	—
V_{SWR}	DC - 3 GHz	Ratio	—	1.2:1	1.4:1
$P_{1\text{dB}}$ (2.3V supply)	500 MHz - 3 GHz	dBm	—	21	—
$P_{1\text{dB}}$ (3V supply)	500 MHz - 3 GHz	dBm	—	27	—
Input IP_2	2-Tone 900 MHz, 5 MHz spacing (3.0 V)	dBm	—	81	—
Input IP_3	2-Tone 900 MHz, 5 MHz spacing (3.0 V)	dBm	—	52	—
Trise, Tfall	10% to 90% RF, 90% to 10% RF	ns	—	25	—
Ton, Toff	50% Control to 90% RF, Control to 10% RF	ns	—	25	—
Transients	In-Band	mV	—	25	—
Control Current	$V_{\text{CTL}} = -2.3$ V	μA	—	4	15

4. External DC blocking capacitors are required on all RF ports when using positive voltage control.

5. Insertion loss can be optimized by varying the DC blocking capacitor value, e.g. 1000 pF for 100 MHz - 1 GHz, 39 pF for 0.5 GHz - 3 GHz.

Truth Table

Mode (Control)	V1	V2	RFC - RF1	RFC - RF2
Positive ⁶	0 ± 0.2 V	+2.3 to +8 V	Off	On
	+2.3 to +8 V	0 ± 0.2 V	On	Off
Negative ⁷	0 ± 0.2 V	-2.3 V to -8 V	On	Off
	-2.3 V to -8 V	0 ± 0.2 V	Off	On

6. External DC blocking capacitors are required on all RF ports. 1000 pF capacitors used for positive control voltage. For higher frequency operation, smaller value DC blocking capacitors can be substituted.

7. If negative control is used, DC blocking capacitors are not required on RF ports.

Qualification

Qualified to M/A-COM specification REL-201, Process Flow -2.

Handling Procedures

Please observe the following precautions to avoid damage:

Static Sensitivity

Gallium Arsenide Integrated Circuits are sensitive to electrostatic discharge (ESD) and can be damaged by static electricity. Proper ESD control techniques should be used when handling these devices.

Lead-Free SC-70 (SOT-363) [†]

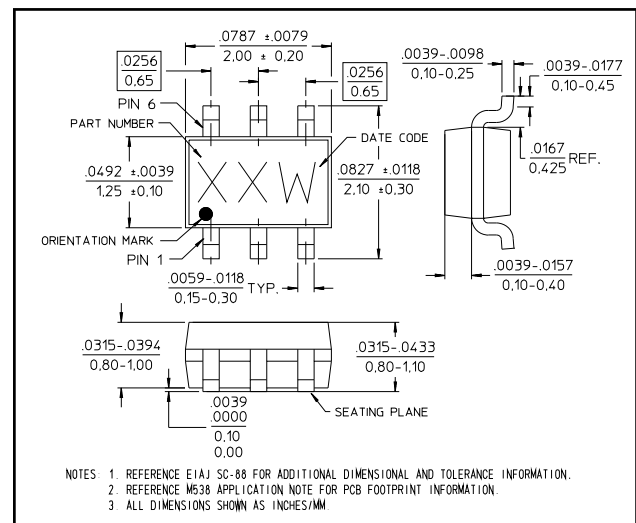

[†] Reference Application Note M538 for lead-free solder reflow recommendations.

Typical Performance Curves

Insertion Loss vs. Frequency Over Temperature

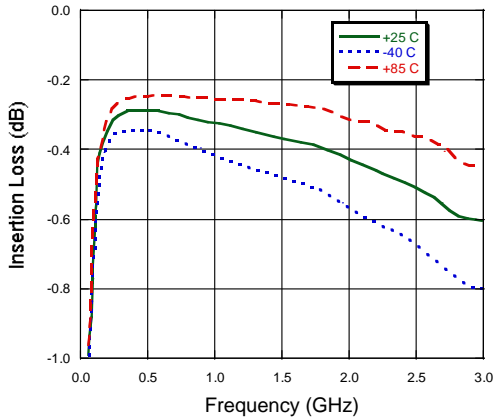

VSWR Over Temperature

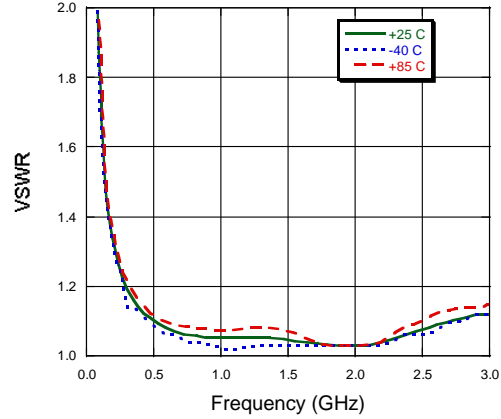

Isolation vs. Frequency Over Temperature

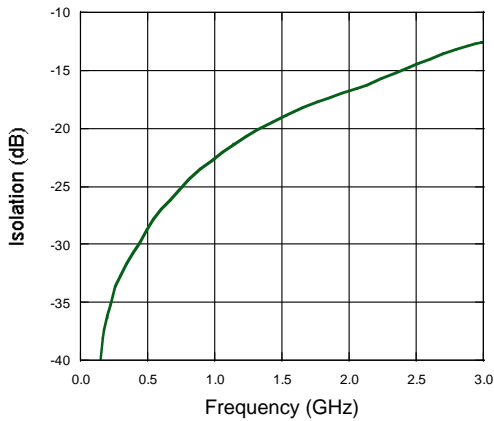

Insertion Loss vs. Frequency (+2.3 V Control, 1000 pF Capacitor on RF Ports)

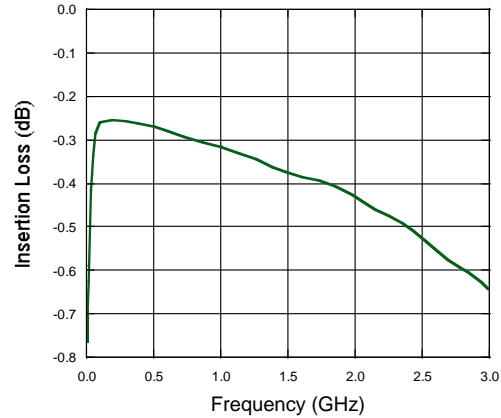

Isolation vs. Frequency (+2.3 V Control, 1000 pF Capacitor on RF Ports)

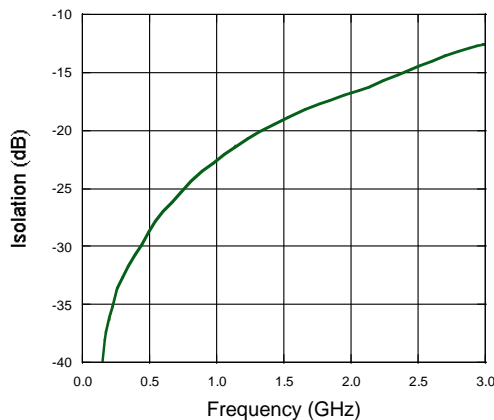

VSWR vs. Frequency (+2.3 V Control, 1000 pF Capacitor on RF Ports)

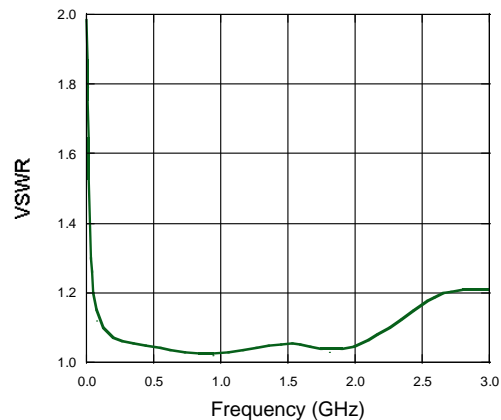

Данный компонент на территории Российской Федерации

Вы можете приобрести в компании MosChip.

Для оперативного оформления запроса Вам необходимо перейти по данной ссылке:

<http://moschip.ru/get-element>

Вы можете разместить у нас заказ для любого Вашего проекта, будь то серийное производство или разработка единичного прибора.

В нашем ассортименте представлены ведущие мировые производители активных и пассивных электронных компонентов.

Нашей специализацией является поставка электронной компонентной базы двойного назначения, продукции таких производителей как XILINX, Intel (ex.ALTERA), Vicor, Microchip, Texas Instruments, Analog Devices, Mini-Circuits, Amphenol, Glenair.

Сотрудничество с глобальными дистрибьюторами электронных компонентов, предоставляет возможность заказывать и получать с международных складов практически любой перечень компонентов в оптимальные для Вас сроки.

На всех этапах разработки и производства наши партнеры могут получить квалифицированную поддержку опытных инженеров.

Система менеджмента качества компании отвечает требованиям в соответствии с ГОСТ Р ИСО 9001, ГОСТ РВ 0015-002 и ЭС РД 009

Офис по работе с юридическими лицами:

105318, г.Москва, ул.Щербаковская д.3, офис 1107, 1118, ДЦ «Щербаковский»

Телефон: +7 495 668-12-70 (многоканальный)

Факс: +7 495 668-12-70 (доб.304)

E-mail: info@moschip.ru

Skype отдела продаж:

moschip.ru

moschip.ru_4

moschip.ru_6

moschip.ru_9