

Molex's LED Array Holder, ideal for OEM light-fixture manufacturers, simplifies the LED installation process for Bridgelux energy-efficient ES and RS Arrays and reduces installation time with compression contacts that eliminate hand soldering

LED technology has been proven to reduce the amount of energy consumed and is becoming a more reliable, efficient and user-friendly way for accommodating general illumination requirements. Using unmatched interconnect technology, Molex provides a solderless solution to mounting LED arrays into OEM designs.

LED array holders simplify the LED installation process by eliminating the need for hand or SMT soldering and expensive SMT equipment. The holders will allow customers to install LED arrays quickly into fixtures, enable field replacements and facilitate upgrades to current applications.

For additional information visit: www.molex.com/link/holderbridgelux.html

For information about additional Solid State Lighting (SSL) that complements Bridgelux and other array products visit: www.molex.com/industry/solidstatelighting.com

FEATURES AND BENEFITS

- Compression contacts to power array simplifies the LED installation process by eliminating hand soldering or expensive Surface Mount Technology (SMT) equipment and reduces installation time
- Double-ended wire-trap terminal to attach power source allows for wiring serial or parallel LED sequences, ensuring ease of array assembly
- Screw-mount attachment method for securing array to heat sink provides voltage isolation between LED and heat sink
- Releasable wire trap for rework or replacement allows for field serviceability
- High-temperature thermoplastic housing supports high heat-generating environments
- Overall array holder form factor is less than 50.00mm (1.96") in diameter for ES arrays and 70.00 by 71.00mm (2.75 by 2.80") for RS arrays is ideal for lamp and small-fixture applications, including MR16 or track lighting
- Clear LED protective cover is available (ES version only) with a snap-lock feature and the IP66 rated cover provides dust and impact protection; provides flexible design options
- Snap-lock feature for optional optic provides aiming of light source, per application

LED Array Holders for Bridgelux* ES and RS Arrays

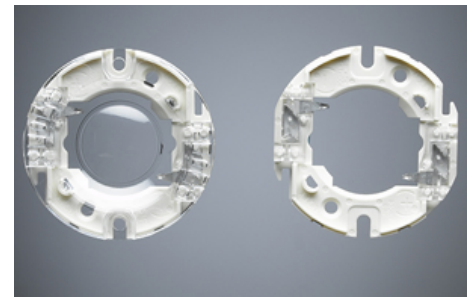

LED Array Holder for Bridgelux ES Array*

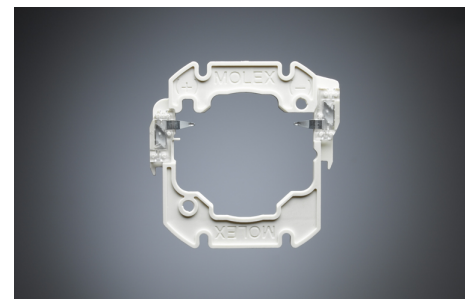

LED Array Holder for Bridgelux RS Array*

SPECIFICATIONS

Reference Information

Packaging: Tray
 UL File No.: Pending
 CSA File No.: Pending
 Designed In: Millimeters
 RoHS: Yes
 REACH: No SVHC

Electrical

Voltage (max.): 300V DC
 Current (max.): 2.5A continuous; 3.5A max.
 Contact Resistance: 20 milliohms max.
 Dielectric Withstanding Voltage: 300V DC
 Insulation Resistance: 5000 milliohms min.

Mechanical

Wire Insertion Force: 5N (1.12lbf) max.
 Wire Pull Out Force: 25N (5.62 lbf) max.
 Durability (min): 20 Cycles

Physical

Overall Diameter:
 ES: 50.00mm (1.96")
 RS: 70.00 by 71.00mm (2.75 by 2.80")
 Housing: PA66 Nylon GF
 Contact: Copper (Cu), Nickel (Ni) and Silver (Ag)
 Plating:
 Contact Area — Silver (Ag)
 Solder Tail Area — Silver (Ag)
 Underplating — Nickel (Ni)

*Bridgelux is a registered trademark of Bridgelux Inc.

APPLICATIONS

- All general illumination applications
 - Downlighting
 - Track
 - Pendants
 - Linear
 - Architectural
 - Decorative
- Area Lighting
 - Roadways
 - Parking Lots
 - Wall Packs

LED Array Holders for Bridgelux* ES and RS Arrays

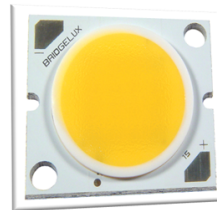

Bridgelux* ES Array

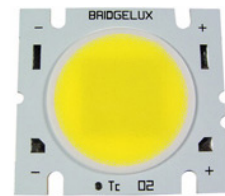

Bridgelux* RS Array



Recessed downlighting in residential and commercial buildings

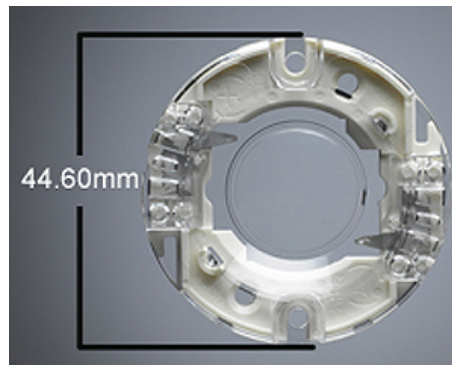

LED Array Holder for Bridgelux* ES Arrays

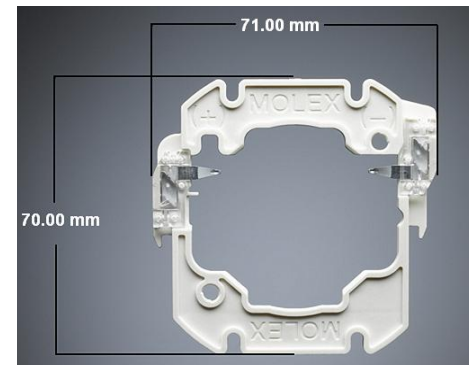

LED Array Holder for Bridgelux* RS Arrays

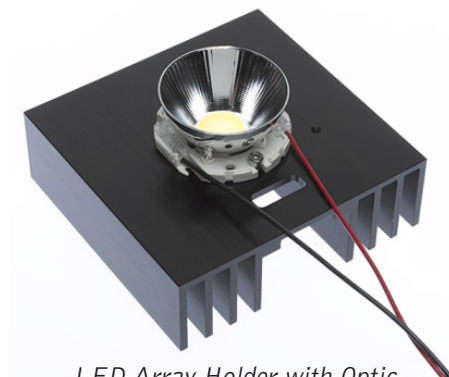

LED Array Holder with Optic for Bridgelux* ES Arrays (optic sold separately from LEDIL)

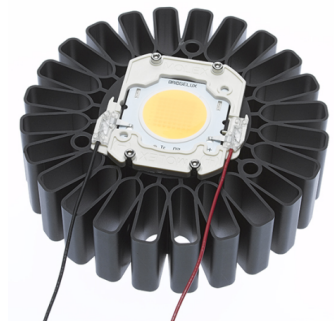

LED Array Holder Mounted to Heat Sink for Bridgelux* RS Arrays (Heat sink sold separately)

ORDERING INFORMATION

Order No.	Holder Version	Plating	Clear Cover
180150-0000	ES	Silver (Ag)	No
180150-0001			Yes
180180-0001	RS		No

*Bridgelux is a registered trademark of Bridgelux Inc.

Данный компонент на территории Российской Федерации

Вы можете приобрести в компании MosChip.

Для оперативного оформления запроса Вам необходимо перейти по данной ссылке:

<http://moschip.ru/get-element>

Вы можете разместить у нас заказ для любого Вашего проекта, будь то серийное производство или разработка единичного прибора.

В нашем ассортименте представлены ведущие мировые производители активных и пассивных электронных компонентов.

Нашей специализацией является поставка электронной компонентной базы двойного назначения, продукции таких производителей как XILINX, Intel (ex.ALTERA), Vicor, Microchip, Texas Instruments, Analog Devices, Mini-Circuits, Amphenol, Glenair.

Сотрудничество с глобальными дистрибьюторами электронных компонентов, предоставляет возможность заказывать и получать с международных складов практически любой перечень компонентов в оптимальные для Вас сроки.

На всех этапах разработки и производства наши партнеры могут получить квалифицированную поддержку опытных инженеров.

Система менеджмента качества компании отвечает требованиям в соответствии с ГОСТ Р ИСО 9001, ГОСТ РВ 0015-002 и ЭС РД 009

Офис по работе с юридическими лицами:

105318, г.Москва, ул.Щербаковская д.3, офис 1107, 1118, ДЦ «Щербаковский»

Телефон: +7 495 668-12-70 (многоканальный)

Факс: +7 495 668-12-70 (доб.304)

E-mail: info@moschip.ru

Skype отдела продаж:

moschip.ru

moschip.ru_4

moschip.ru_6

moschip.ru_9