



# Technical Data Sheet

## 7343-2USRC/S1060

### Features

- Popular T-1 3/4package.
- High efficiency.
- General purpose leads.
- Selected minimum intensities.
- Available on tape and reel.
- Pb free .



### Descriptions

- The series is specially designed for applications requiring higher brightness.
- The LED lamps are available with different colors, intensities, epoxy colors ,etc.
- Superior performance in outdoor environment.

### Applications

- Status indicators.
- Commercial use.
- Advertising Signs.

### Device Selection Guide

LED Part No.	Chip		Lens Color
	Material	Emitted Color	
7343-2USRC/S1060	AlGaInP	Super Red	Water Clear

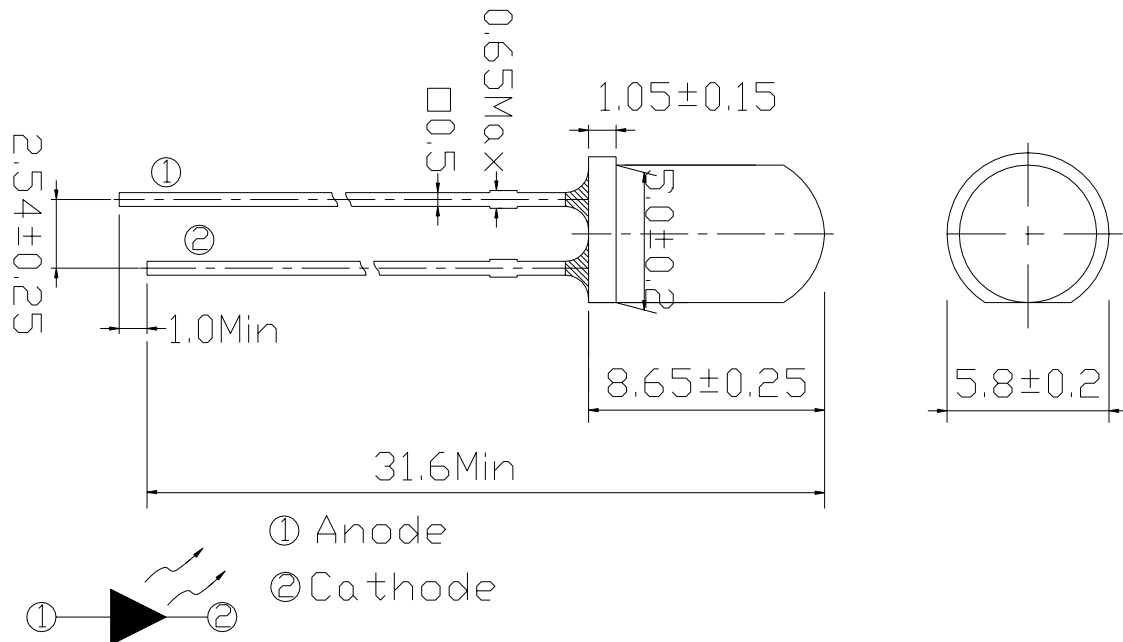
**Package Dimensions**

**Notes:**

- All dimensions are in millimeters, tolerance is 0.25mm except being specified.
- Lead spacing is measured where the lead emerges from the package.
- Protruded resin under flange is 1.5mm Max LED.

**Absolute Maximum Ratings (Ta=25°C)**

Parameter	Symbol	Rating	Units
Forward Current	$I_F$	50	mA
Pulse Forward Current(Duty 1/10 @ 1kHz) <sup>*1</sup>	$I_{FP}$	100	mA
Operating Temperature	$T_{opr}$	-40 ~ +85	°C
Storage Temperature	$T_{stg}$	-40 ~ +100	°C
LED Junction Temperature	$T_{jmax}$	125	°C
Electrostatic Discharge	ESD	2000	V
Soldering Temperature <sup>*2</sup>	$T_{sol}$	260 ±5	°C
Through-the-Wave Preheat Temperature	----	145	°C
Power Dissipation	$P_d$	100	mW
Reverse Voltage	$V_R$	5	V

**Notes:** \*1: $I_{FP}$  Conditions--Pulse Width  $\leq 10$ msec and Duty  $\leq 1/10$ .

\*2:Soldering time  $\leq 5$  seconds.

**Electro-Optical Characteristics (Ta=25°C)**

Parameter	Symbol	Condition	Min.	Typ.	Max.	Units
Forward Voltage	$V_F$	$I_F=20mA$	--	2.0	2.6	V
Reverse Current	$I_R$	$V_R=5V$	--	--	10	$\mu A$
Radiance Intensity	$I_V$	$I_F=20mA$	2500	4000	--	mcd
Viewing Angle	$2\theta_{1/2}$	$I_F=20mA$	--	30	--	deg
Peak Wavelength	$\lambda_p$	$I_F=20mA$	--	639	--	nm
Dominant Wavelength	$\lambda_d$	$I_F=20mA$	--	631	--	nm
Spectrum Radiation Bandwidth	$\Delta\lambda$	$I_F=20mA$	--	20	--	nm

**Typical Electro-Optical Characteristics Curves**

**Relative Intensity vs. Wavelength**

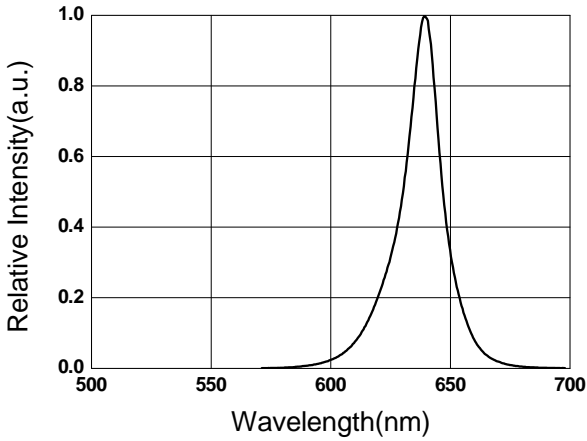

**Forward Current vs. Forward Voltage**

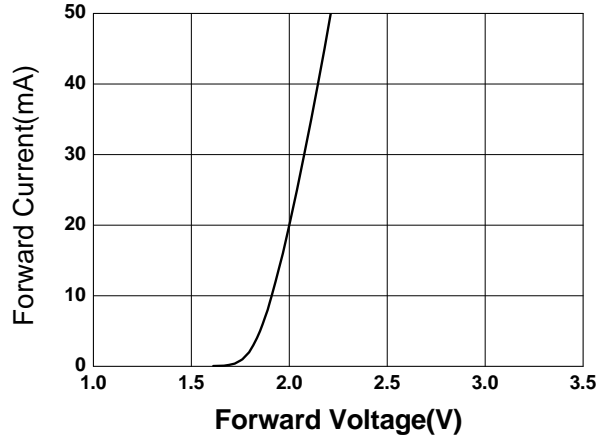

**Relative Intensity vs. Ambient Temp**

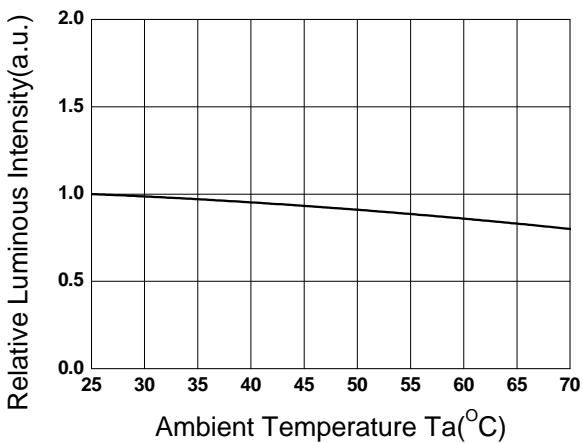

**Forward Current vs. Relative Intensity**

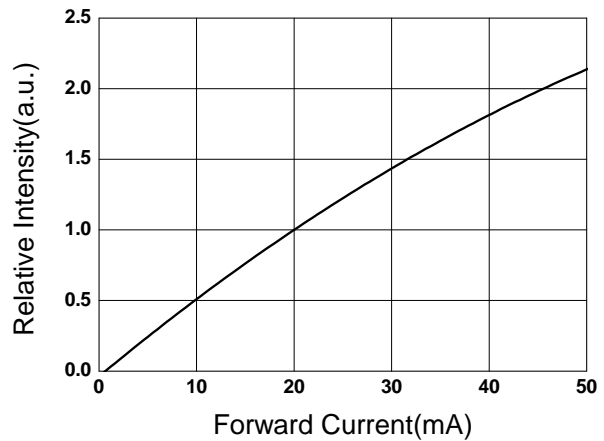

**Forward Current vs. Ambient Temp.**

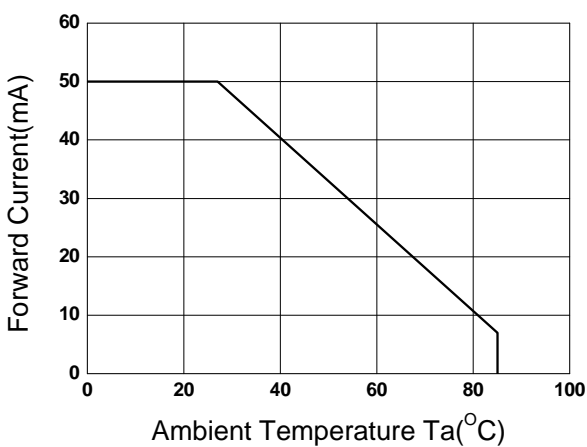

**Radiation Characteristics**

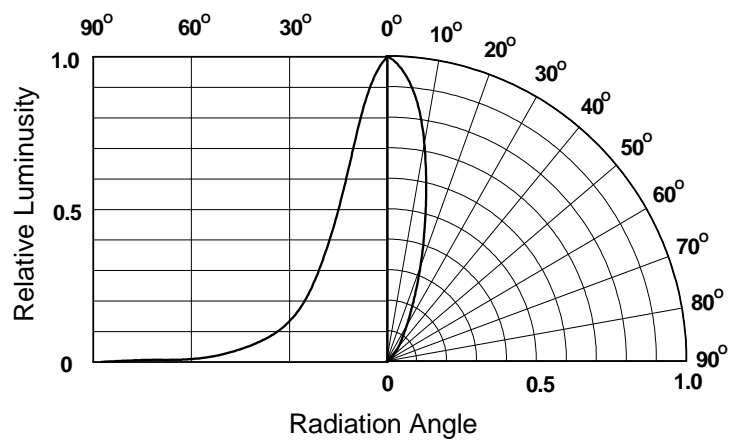



**Packing Quantity Specification**

- 1. 500 PCS/1 Anti ESD Bag
- 2. 5 Anti ESD Bags /1 Box
- 3. 10 Boxes/1 Carton

**Label Form Specification**

CPN:	
P/N:	
7343-2USRC/S1060	
QTY :	CAT:
LOT NO :	HUE:
MADE IN TAIWAN	

CPN: Customer's Production Number  
P/N : Production Number  
7343-2USRC/S1060:Production name  
QTY: Packing Quantity  
CAT: Ranks of Luminous and Forward Voltage  
HUE: Ranks of Dominant Wavelength  
REF: Reference  
LOT No: Lot Number  
MADE IN TAIWAN: Production Place

**Notes**

- 1. Above specification may be changed without notice. EVERLIGHT will reserve authority on material change for above specification.
- 2. When using this product, please observe the absolute maximum ratings and the instructions for using outlined in these specification sheets. EVERLIGHT assumes no responsibility for any damage resulting from use of the product which does not comply with the absolute maximum ratings and the instructions included in these specification sheets.
- 3. These specification sheets include materials protected under copyright of EVERLIGHT corporation. Please don't reproduce or cause anyone to reproduce them without EVERLIGHT's consent.

<b>EVERLIGHT ELECTRONICS CO., LTD.</b> Office: No 25, Lane 76, Sec 3, Chung Yang Rd, Tucheng, Taipei 236, Taiwan, R.O.C	Tel: 886-2-2267-2000, 2267-9936 Fax: 886-2267-6244, 2267-6189, 2267-6306 <a href="http://www.everlight.com">http://www.everlight.com</a>
---	--

## Данный компонент на территории Российской Федерации

### Вы можете приобрести в компании MosChip.

Для оперативного оформления запроса Вам необходимо перейти по данной ссылке:

<http://moschip.ru/get-element>

Вы можете разместить у нас заказ для любого Вашего проекта, будь то серийное производство или разработка единичного прибора.

В нашем ассортименте представлены ведущие мировые производители активных и пассивных электронных компонентов.

Нашей специализацией является поставка электронной компонентной базы двойного назначения, продукции таких производителей как XILINX, Intel (ex.ALTERA), Vicor, Microchip, Texas Instruments, Analog Devices, Mini-Circuits, Amphenol, Glenair.

Сотрудничество с глобальными дистрибьюторами электронных компонентов, предоставляет возможность заказывать и получать с международных складов практически любой перечень компонентов в оптимальные для Вас сроки.

На всех этапах разработки и производства наши партнеры могут получить квалифицированную поддержку опытных инженеров.

Система менеджмента качества компании отвечает требованиям в соответствии с ГОСТ Р ИСО 9001, ГОСТ РВ 0015-002 и ЭС РД 009

### Офис по работе с юридическими лицами:

105318, г.Москва, ул.Щербаковская д.3, офис 1107, 1118, ДЦ «Щербаковский»

Телефон: +7 495 668-12-70 (многоканальный)

Факс: +7 495 668-12-70 (доб.304)

E-mail: [info@moschip.ru](mailto:info@moschip.ru)

Skype отдела продаж:

moschip.ru

moschip.ru\_4

moschip.ru\_6

moschip.ru\_9