

# CAT4101AGEVB

## CAT4101 LED Driver Evaluation Board User's Manual



ON Semiconductor®

<http://onsemi.com>

### EVAL BOARD USER'S MANUAL

#### Introduction

This document describes the CAT4101AGEVB evaluation board for the ON Semiconductor CAT4101 low dropout current sink. The functionality and major parameters of the CAT4101 can be evaluated with the CAT4101AGEVB board.

The CAT4101 is a low dropout current sink capable of driving strings of high-brightness LEDs up to 1 A. The current sink is programmed by a single resistor from the RSET pin to GND. Enable and dimming control is available via the EN/PWM pin. Additional details and electrical characteristics can be found in the CAT4101 data sheet.

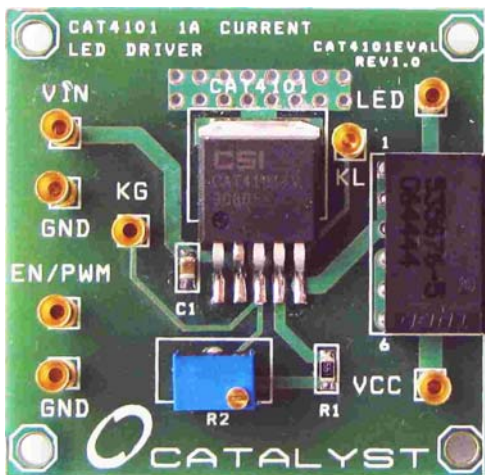

Figure 1. CAT4101AGEVB Board

#### Board Hardware

The evaluation board contains one CAT4101 in a typical application circuit. A six pin header receptacle is available to connect strings of LED modules. If LED modules are not available, a separate LED string can be used by connecting the cathode end to the LED test point.

The VIN test point is connected to the VIN supply of the CAT4101. The voltage between test points VIN and GND should not exceed 6.0 V.

The EN/PWM test point is the enable and PWM input for the CAT4101. The control signal should be connected between test points EN/PWM and GND.

Trimmer potentiometer R2 can be adjusted to change the LED current. The RSET pin of the CAT4101 is a fixed 1.2 V reference and the LED current is set by changing the current through the RSET resistor (R1 + R2).

The CAT4101 has a typical dropout voltage of 500 mV for 1 A LED current. To measure the dropout there are kelvin connections at test points KL and KG. These connections allow for accurate measurement of the LED pin voltage. At high current, there could be a significant voltage drop across board traces. These test points should be used for measurement purposes only as they are not meant to carry any current.

# CAT4101AGEVB

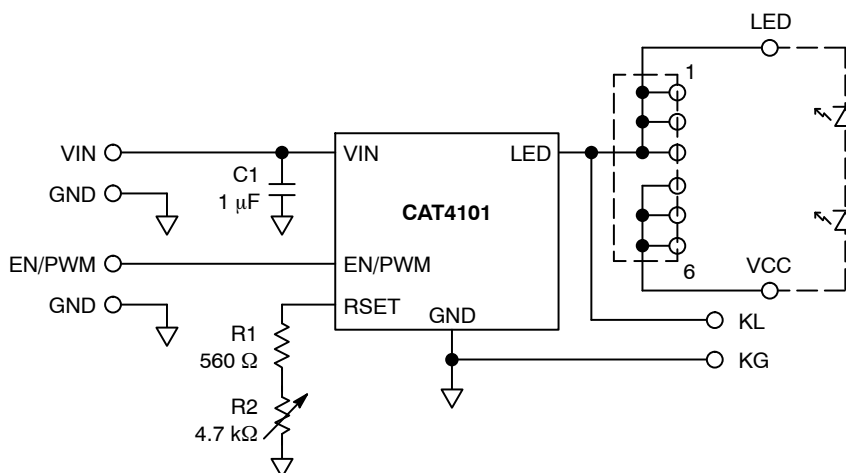

Figure 2. CAT4101AGEVB Board Schematic

Table 1. CAT4101AGEVB BOARD LIST OF COMPONENTS

Name	Manufacturer	Description	Part Number	Units
U1	ON Semiconductor	Low Dropout Current Sink, TO-263-5	CAT4101TV	1
C1	Taiyo Yuden	Ceramic Capacitor 1 μF/10 V, 10%, X7R, Size 0805	LMK212B7105KD-T	1
R1	Yageo	SMT Resistor 1/8 W, 560 Ω, Size 0805	RC0805FR-07560RL	1
R2	Vishay	Trimmer Potentiometer, 4.7 kΩ	T63YB472K	1
	Tyco	6 Pin Header Receptacle 0.1" Pitch	535676-5	1

ON Semiconductor and are registered trademarks of Semiconductor Components Industries, LLC (SCILLC). SCILLC reserves the right to make changes without further notice to any products herein. SCILLC makes no warranty, representation or guarantee regarding the suitability of its products for any particular purpose, nor does SCILLC assume any liability arising out of the application or use of any product or circuit, and specifically disclaims any and all liability, including without limitation special, consequential or incidental damages. "Typical" parameters which may be provided in SCILLC data sheets and/or specifications can and do vary in different applications and actual performance may vary over time. All operating parameters, including "Typicals" must be validated for each customer application by customer's technical experts. SCILLC does not convey any license under its patent rights nor the rights of others. SCILLC products are not designed, intended, or authorized for use as components in systems intended for surgical implant into the body, or other applications intended to support or sustain life, or for any other application in which the failure of the SCILLC product could create a situation where personal injury or death may occur. Should Buyer purchase or use SCILLC products for any such unintended or unauthorized application, Buyer shall indemnify and hold SCILLC and its officers, employees, subsidiaries, affiliates, and distributors harmless against all claims, costs, damages, and expenses, and reasonable attorney fees arising out of, directly or indirectly, any claim of personal injury or death associated with such unintended or unauthorized use, even if such claim alleges that SCILLC was negligent regarding the design or manufacture of the part. SCILLC is an Equal Opportunity/Affirmative Action Employer. This literature is subject to all applicable copyright laws and is not for resale in any manner.

## PUBLICATION ORDERING INFORMATION

**LITERATURE FULFILLMENT:**  
Literature Distribution Center for ON Semiconductor  
P.O. Box 5163, Denver, Colorado 80217 USA  
**Phone:** 303-675-2175 or 800-344-3860 Toll Free USA/Canada  
**Fax:** 303-675-2176 or 800-344-3867 Toll Free USA/Canada  
**Email:** orderlit@onsemi.com

**N. American Technical Support:** 800-282-9855 Toll Free  
USA/Canada  
**Europe, Middle East and Africa Technical Support:**  
Phone: 421 33 790 2910  
**Japan Customer Focus Center**  
Phone: 81-3-5773-3850

**ON Semiconductor Website:** [www.onsemi.com](http://www.onsemi.com)  
**Order Literature:** <http://www.onsemi.com/orderlit>

For additional information, please contact your local Sales Representative

## Данный компонент на территории Российской Федерации

### Вы можете приобрести в компании MosChip.

Для оперативного оформления запроса Вам необходимо перейти по данной ссылке:

<http://moschip.ru/get-element>

Вы можете разместить у нас заказ для любого Вашего проекта, будь то серийное производство или разработка единичного прибора.

В нашем ассортименте представлены ведущие мировые производители активных и пассивных электронных компонентов.

Нашей специализацией является поставка электронной компонентной базы двойного назначения, продукции таких производителей как XILINX, Intel (ex.ALTERA), Vicor, Microchip, Texas Instruments, Analog Devices, Mini-Circuits, Amphenol, Glenair.

Сотрудничество с глобальными дистрибьюторами электронных компонентов, предоставляет возможность заказывать и получать с международных складов практически любой перечень компонентов в оптимальные для Вас сроки.

На всех этапах разработки и производства наши партнеры могут получить квалифицированную поддержку опытных инженеров.

Система менеджмента качества компании отвечает требованиям в соответствии с ГОСТ Р ИСО 9001, ГОСТ РВ 0015-002 и ЭС РД 009

### Офис по работе с юридическими лицами:

105318, г.Москва, ул.Щербаковская д.3, офис 1107, 1118, ДЦ «Щербаковский»

Телефон: +7 495 668-12-70 (многоканальный)

Факс: +7 495 668-12-70 (доб.304)

E-mail: [info@moschip.ru](mailto:info@moschip.ru)

Skype отдела продаж:

moschip.ru

moschip.ru\_4

moschip.ru\_6

moschip.ru\_9