



# TAOGLAS®



## Datasheet

### 8 Ohm 4x6 Inch Coaxial Speaker with Foam Gasket

**Part No:**  
SPKA.46.8.B

**Description:**

4x6" Speaker Foam Gasket 8 Ohm with Delphi 12052832 connector

**Features:**

- 8 Ohm Impedance
- Foam Gasket
- Rated Power 25W
- High Sensitivity
- Distortion Free
- Dimensions: 158x107x56mm
- Connector: Delphi 12052832
- RoHS & Reach Compliant

1. Introduction	3
2. Specifications	4
3. Speaker Characteristics	5
4. Mechanical Drawing	6
5. Packaging	7
<hr/>	
Changelog	8

Taoglas makes no warranties based on the accuracy or completeness of the contents of this document and reserves the right to make changes to specifications and product descriptions at any time without notice. Taoglas reserves all rights to this document and the information contained herein.

Reproduction, use or disclosure to third parties without express permission is strictly prohibited.

Copyright © Taoglas Ltd.



## 1. Introduction



Designed for the rugged environment of heavy-duty trucks, Taoglas speakers deliver long lasting pure and true sound. Our 8-Ohm 4x6-inch Coaxial Speaker, full range high sensitivity speaker series provide distortion free audio, high fidelity, high power handling (25W RMS) and is a low-cost solution for heavy-duty applications such as Transportation, Truck and RV applications. It is also primed for IoT applications such as Smart Home and Agriculture in which the use of speakers is becoming more commonplace. With this in mind Taoglas has decided to add speakers to our extensive product catalogue in order to make the customers journey easier, as now we can provide a high quality antenna solution and a high quality speaker solution from one trusted company.

Taoglas' slim design, full range speakers are easy to install. Multiple mounting hole patterns provide flexibility for attaching to a vehicle door panel or integrating into a home Hi-Fi speaker cabinet. Installation requires just two cables to be routed.

The SPKA.46.8.B unlike the SPKA.46.8.A model comes with a spongy foam gasket making it the perfect solution for installation location where rattle noise through vibration can be problematic.

Contact your local Taoglas customer service team for more information or installation guidelines.

## 2. Specifications

Electrical	
Impedance	8Ω
Rated Power	25W
Maximum Input Power	50W
Mechanical	
Dimensions	158x107x56mm
Weight	0.6Kg
Connector	Delphi 12052832
Environmental	
Temperature Range	-40°C to 85°C
Humidity	Non-condensing 65°C 95% RH

### 3. Speaker Characteristics

#### 3.1 SPL

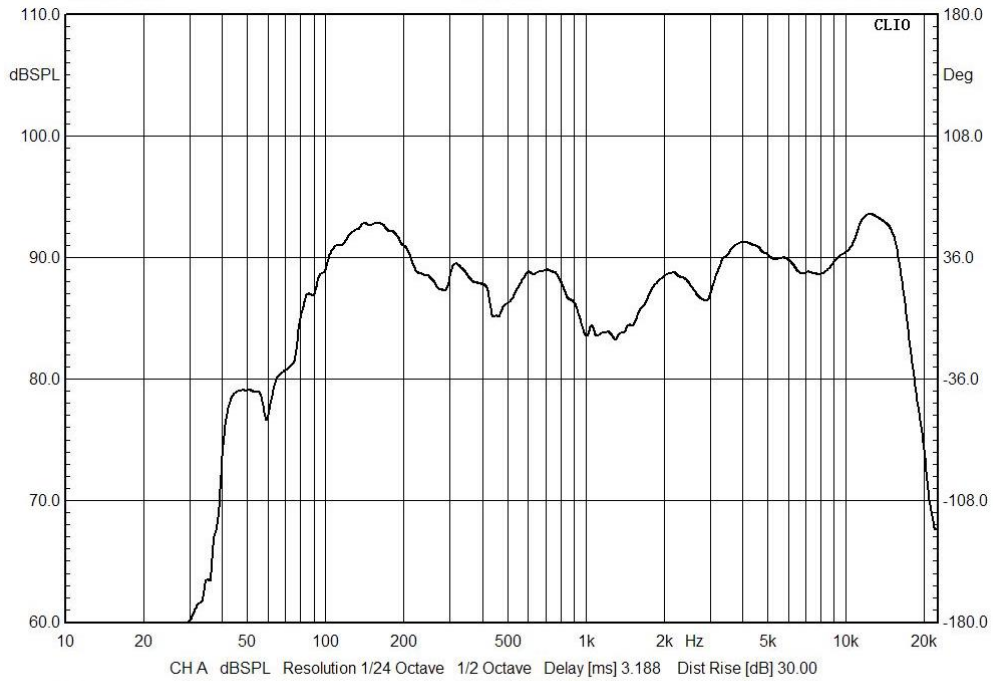

#### 3.2 Impedance

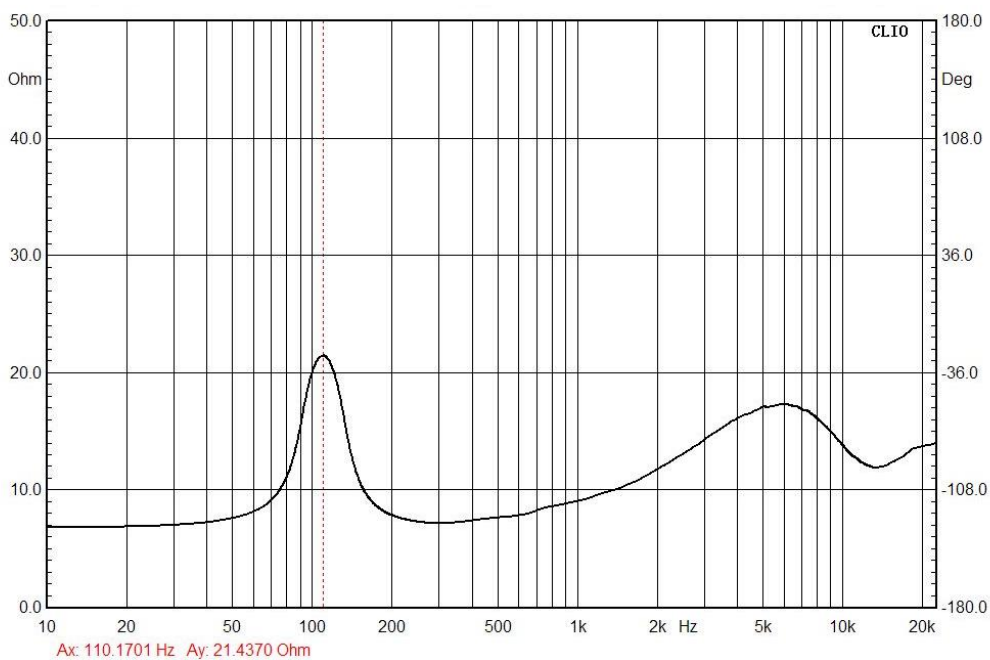

# 4. Mechanical Drawing (Units: mm)

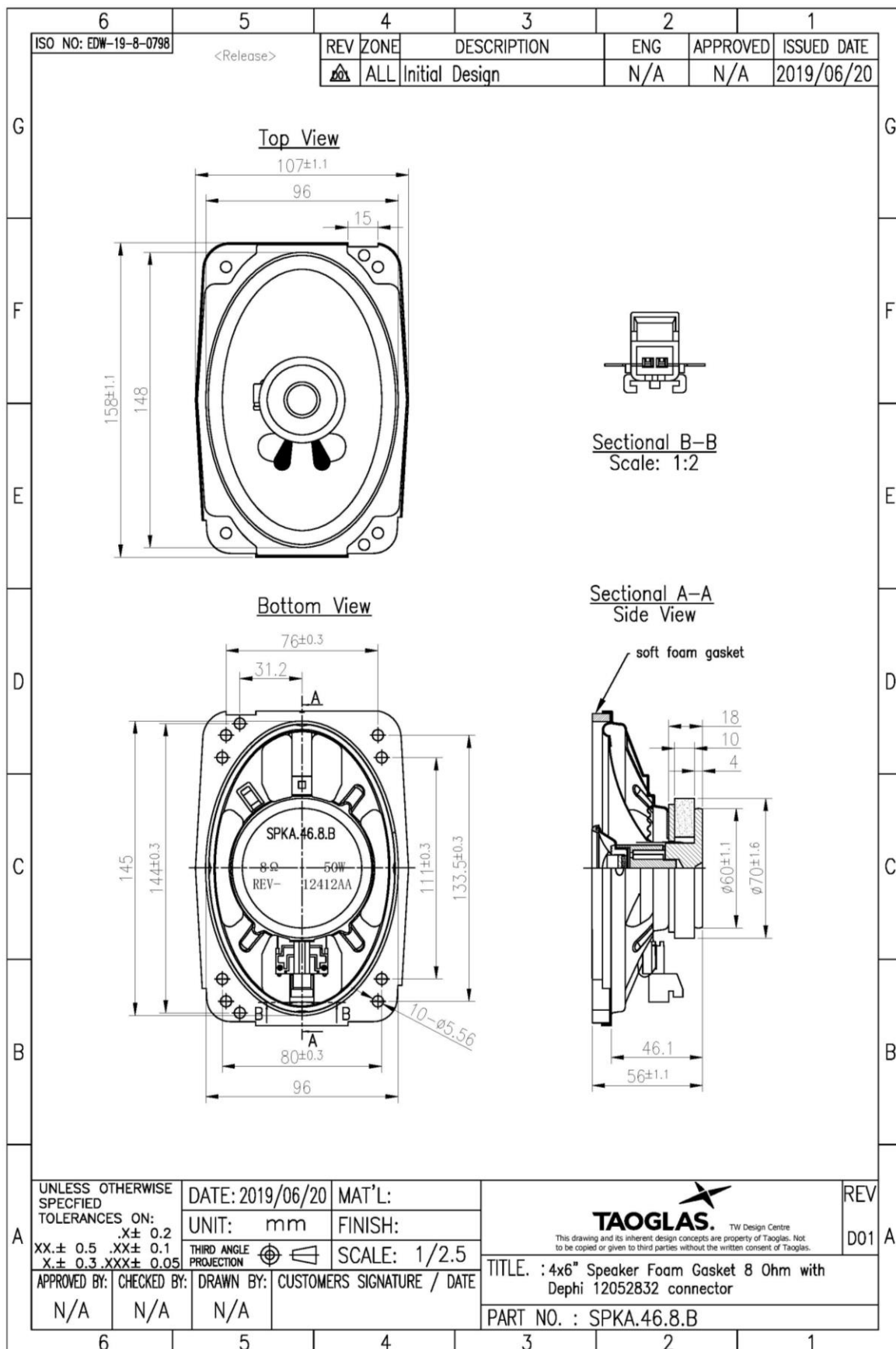

## 5. Packaging

1pcs SPKA.46.8.B per Box  
 Dimensions – 165x115x65mm  
 Weight – 0.6Kg

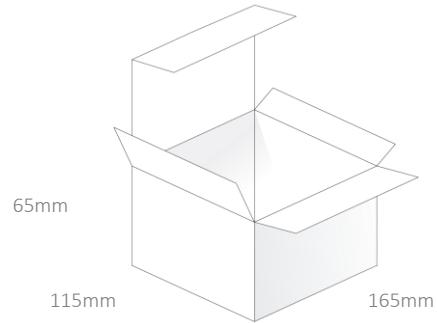

18pcs SPKA.46.8.B per carton  
 Dimensions – 523x436x125mm  
 Weight – 12.5Kg

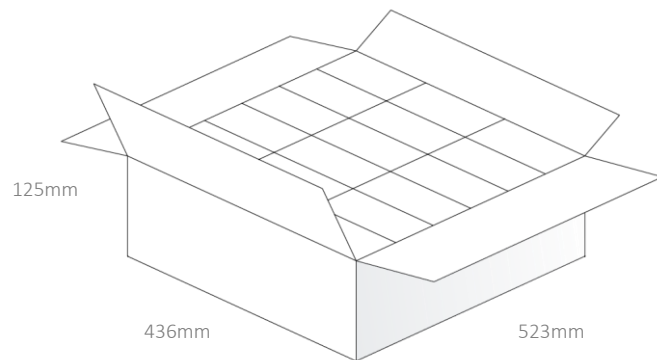

Changelog for the datasheet

**SPE-19-8-042 – SPKA.46.8.B**

**Revision: A (Current Version)**

Date:	2019-05-02
Changes:	
Changes Made by:	Jack Conroy

**Previous Revisions**





**TAOGLAS®**

[www.taoglas.com](http://www.taoglas.com)



## Данный компонент на территории Российской Федерации

### Вы можете приобрести в компании MosChip.

Для оперативного оформления запроса Вам необходимо перейти по данной ссылке:

<http://moschip.ru/get-element>

Вы можете разместить у нас заказ для любого Вашего проекта, будь то серийное производство или разработка единичного прибора.

В нашем ассортименте представлены ведущие мировые производители активных и пассивных электронных компонентов.

Нашей специализацией является поставка электронной компонентной базы двойного назначения, продукции таких производителей как XILINX, Intel (ex.ALTERA), Vicor, Microchip, Texas Instruments, Analog Devices, Mini-Circuits, Amphenol, Glenair.

Сотрудничество с глобальными дистрибьюторами электронных компонентов, предоставляет возможность заказывать и получать с международных складов практически любой перечень компонентов в оптимальные для Вас сроки.

На всех этапах разработки и производства наши партнеры могут получить квалифицированную поддержку опытных инженеров.

Система менеджмента качества компании отвечает требованиям в соответствии с ГОСТ Р ИСО 9001, ГОСТ РВ 0015-002 и ЭС РД 009

### Офис по работе с юридическими лицами:

105318, г.Москва, ул.Щербаковская д.3, офис 1107, 1118, ДЦ «Щербаковский»

Телефон: +7 495 668-12-70 (многоканальный)

Факс: +7 495 668-12-70 (доб.304)

E-mail: [info@moschip.ru](mailto:info@moschip.ru)

Skype отдела продаж:

moschip.ru

moschip.ru\_4

moschip.ru\_6

moschip.ru\_9