



Features

- Compact design, long life and high reliability
- Momentary push switch option
- Available in a wide variety of configurations to meet many user requirements



PEC12R - 12 mm Incremental Encoder

Electrical Characteristics

Output	2-bit quadrature code
Contact Rating	10 mA @ 5 VDC
Insulation Resistance	10 megohms @ 250 VDC
Dielectric Withstanding Voltage	
Sea Level	50 VAC minimum
Electrical Travel	Continuous
Contact Bounce (15 RPM)	2.0 ms. maximum**
RPM (Operating)	100 maximum**

Environmental Characteristics

Operating Temperature Range	-30 °C to +70 °C (-22 °F to +158 °F)
Storage Temperature Range	-40 °C to +85 °C (-40 °F to +185 °F)
Humidity	MIL-STD-202, Method 103B, Condition B
Vibration	10~55~10 Hz / 1 min. / Amplitude 1.5 mm
Shock	100 G
Rotational Life	30,000 cycles minimum
Switch Life	20,000 cycles minimum
IP Rating	IP 40

Mechanical Characteristics

Mechanical Angle	360 ° continuous
Torque	
Running	30.6 to 204 g-cm (0.42 to 2.83 oz.-in.)
Mounting	10.2 kgf.cm (8.83 lb.-in.) maximum
Shaft Side Load (Static)	2.04 kgf (4.5 lbs.) minimum
Weight	3 gm (0.1 oz.) maximum
Terminals	Printed circuit board terminals
Terminals	Printed circuit board terminals
Soldering Condition	
Wave Soldering	Sn95.5/Ag2.8/Cu0.7 solder with no-clean flux: 260 °C max. for 3 ± 1 sec.
Hand Soldering	Not recommended
Hardware	One flat washer and one mounting nut supplied with each encoder with bushing

Switch Characteristics

Switch Type	Contact Push ON Momentary SPST
Power Rating (Resistive Load)	10 mA at 5 V DC
Switch Travel	0.5 ± 0.3 mm
Switch Actuation Force	610 ± 306 gf (8.47 ± 4.24 oz.-in.)
Contact Resistance	100 milliohms @ 5 VDC

How To Order

	PEC12R - 4 0 20 F - S 0012	
Model	PEC12R	0012
Terminal/Bushing Configuration	4	0
2 = Vertical Mount - Radial PC Pin/No Bushing		
3 = Horizontal Mount - Axial PC Pin/with Bushing		
4 = Horizontal Mount - Axial PC Pin/No Bushing		
Detent Option	0	20
0 = No Detents		
1 = 12 Detents (available with 12 pulses only)		
2 = 24 Detents		
Standard Shaft Length	22 = 22.5 mm	
15 = 15.0 mm (Horizontal Mount/No Bushing only)	25 = 25.0 mm	
17 = 17.5 mm	30 = 30.0 mm	
20 = 20.0 mm		
Shaft Style	F	
F = Insulated Flatted Shaft		
Switch Configuration	S	
S = Push Momentary Switch		
N = No Switch		
Resolution		0012
0012 = 12 Pulses per 360 ° Rotation		
0024 = 24 Pulses per 360 ° Rotation		

Quadrature Output Table

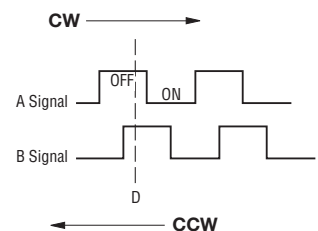

*RoHS Directive 2002/95/EC Jan. 27, 2003 including annex and RoHS Recast 2011/65/EU June 8, 2011.

**Devices are tested using standard noise reduction filters. For optimum performance, designers should use noise reduction filters in their circuits. Specifications are subject to change without notice.

The device characteristics and parameters in this data sheet can and do vary in different applications and actual device performance may vary over time. Users should verify actual device performance in their specific applications.

Applications

Level control, tuning and timer settings in:

- Audio-visual equipment
- Consumer electric appliances
- Musical instrumentation
- Communications equipment

PEC12R - 12 mm Incremental Encoder **BOURNS®**

Product Dimensions

PEC12R-2xxxF-Nxxxx (Vertical Mount - Radial PC Pin/No Bushing, No Switch)

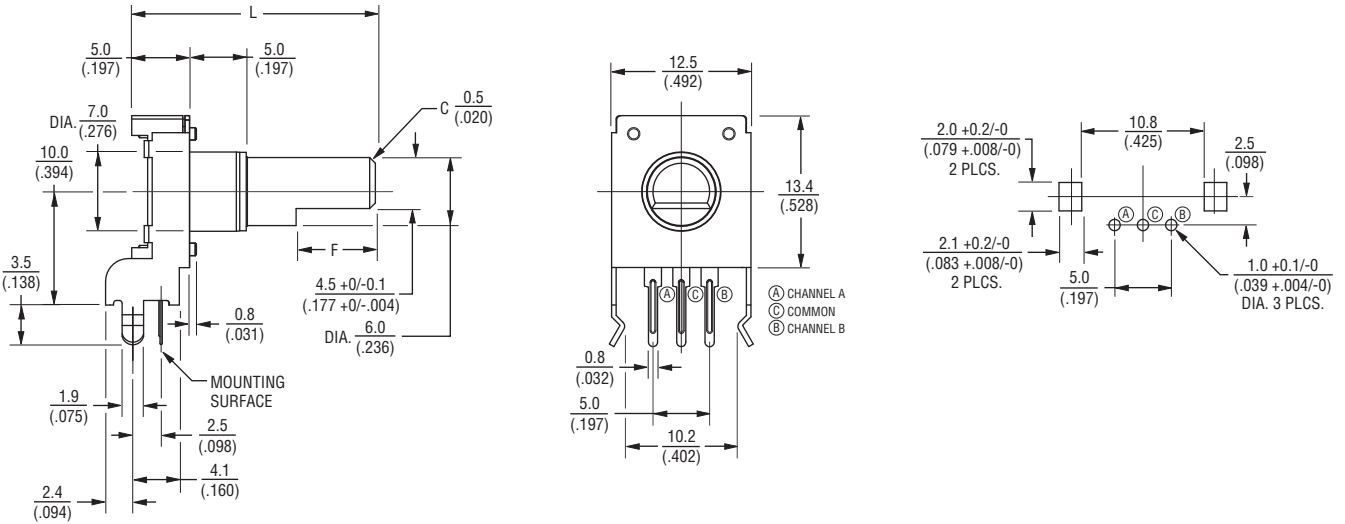

PEC12R-2xxxF-Sxxxx (Vertical Mount - Radial PC Pin/No Bushing, Push Momentary Switch)



Switch Circuit

Suggested Filter Circuit

	L	17.5 (.688)	20.0 (.787)	22.5 (.886)	25.0 (.984)	30.0 (1.181)
	F	5.0 (.197)	7.0 (.276)	7.0 (.276)	12.0 (.472)	12.0 (.472)



DIMENSIONS: $\frac{\text{MM}}{\text{(INCHES)}}$

TOLERANCE: $\frac{<10}{(<.400)} = \frac{\pm 0.3}{(\pm .012)}$

$\frac{\ge 10}{(\ge .400)} = \frac{\pm 0.5}{(\pm .020)}$



Specifications are subject to change without notice. The device characteristics and parameters in this data sheet can and do vary in different applications and actual device performance may vary over time. Users should verify actual device performance in their specific applications.

PEC12R - 12 mm Incremental Encoder

BOURNS®

Product Dimensions

PEC12R-3xxxF-Nxxxx (Horizontal Mount - Axial PC Pin/with Bushing, No Switch)



PEC12R-3xxxF-Sxxxx (Horizontal Mount - Axial PC Pin/with Bushing, Push Momentary Switch)



L	$\frac{17.5}{(.688)}$	$\frac{20.0}{(.787)}$	$\frac{22.5}{(.886)}$	$\frac{25.0}{(.984)}$	$\frac{30.0}{(1.181)}$
LB	$\frac{5.0}{(.197)}$	$\frac{5.0}{(.197)}$	$\frac{7.0}{(.276)}$	$\frac{7.0}{(.276)}$	$\frac{7.0}{(.276)}$
F	$\frac{5.0}{(.197)}$	$\frac{7.0}{(.276)}$	$\frac{7.0}{(.276)}$	$\frac{12.0}{(.472)}$	$\frac{12.0}{(.472)}$

DIMENSIONS: $\frac{\text{MM}}{\text{(INCHES)}}$

TOLERANCE: $\frac{<10}{(<.400)} = \frac{\pm 0.3}{(\pm .012)}$

$\frac{\geq 10}{(\geq .400)} = \frac{\pm 0.5}{(\pm .020)}$

Specifications are subject to change without notice.

The device characteristics and parameters in this data sheet can and do vary in different applications and actual device performance may vary over time. Users should verify actual device performance in their specific applications.

PEC12R - 12 mm Incremental Encoder

BOURNS®

Product Dimensions

PEC12R-4xxxF-Nxxxx (Horizontal Mount - Axial PC Pin/No Bushing, No Switch)



PEC12R-4xxxF-Sxxxx (Horizontal Mount - Axial PC Pin/No Bushing, Push Momentary Switch)



L	15.0 (.591)	17.5 (.688)	20.0 (.787)	22.5 (.886)	25.0 (.984)	30.0 (1.181)
LB	2.0 (.079)	5.0 (.197)	5.0 (.197)	5.0 (.197)	5.0 (.197)	5.0 (.197)
F	5.0 (.197)	5.0 (.197)	7.0 (.276)	7.0 (.276)	12.0 (.472)	12.0 (.472)

DIMENSIONS: $\frac{\text{MM}}{(\text{INCHES})}$

TOLERANCE: $\frac{<10}{(<.400)} = \pm 0.3$
 $\frac{(\pm 0.012)}{(\pm 0.012)}$

$\frac{\geq 10}{(\geq .400)} = \pm 0.5$
 $\frac{(\pm 0.020)}{(\pm 0.020)}$

BOURNS®

Asia-Pacific:
 Tel: +886-2 2562-4117
 Fax: +886-2 2562-4116

EMEA:
 Tel: +36 88 520 390
 Fax: +36 88 520 211

The Americas:
 Tel: +1-951 781-5500
 Fax: +1-951 781-5700

www.bourns.com

REV. 04/15

Specifications are subject to change without notice.

The device characteristics and parameters in this data sheet can and do vary in different applications and actual device performance may vary over time.

Users should verify actual device performance in their specific applications.

Данный компонент на территории Российской Федерации

Вы можете приобрести в компании MosChip.

Для оперативного оформления запроса Вам необходимо перейти по данной ссылке:

<http://moschip.ru/get-element>

Вы можете разместить у нас заказ для любого Вашего проекта, будь то серийное производство или разработка единичного прибора.

В нашем ассортименте представлены ведущие мировые производители активных и пассивных электронных компонентов.

Нашей специализацией является поставка электронной компонентной базы двойного назначения, продукции таких производителей как XILINX, Intel (ex.ALTERA), Vicor, Microchip, Texas Instruments, Analog Devices, Mini-Circuits, Amphenol, Glenair.

Сотрудничество с глобальными дистрибьюторами электронных компонентов, предоставляет возможность заказывать и получать с международных складов практически любой перечень компонентов в оптимальные для Вас сроки.

На всех этапах разработки и производства наши партнеры могут получить квалифицированную поддержку опытных инженеров.

Система менеджмента качества компании отвечает требованиям в соответствии с ГОСТ Р ИСО 9001, ГОСТ РВ 0015-002 и ЭС РД 009

Офис по работе с юридическими лицами:

105318, г.Москва, ул.Щербаковская д.3, офис 1107, 1118, ДЦ «Щербаковский»

Телефон: +7 495 668-12-70 (многоканальный)

Факс: +7 495 668-12-70 (доб.304)

E-mail: info@moschip.ru

Skype отдела продаж:

moschip.ru

moschip.ru_4

moschip.ru_6

moschip.ru_9