

THIS COPY IS PROVIDED ON A RESTRICTED BASIS AND IS NOT TO BE USED IN ANY WAY DETRIMENTAL TO THE INTERESTS OF PANDUIT CORP.

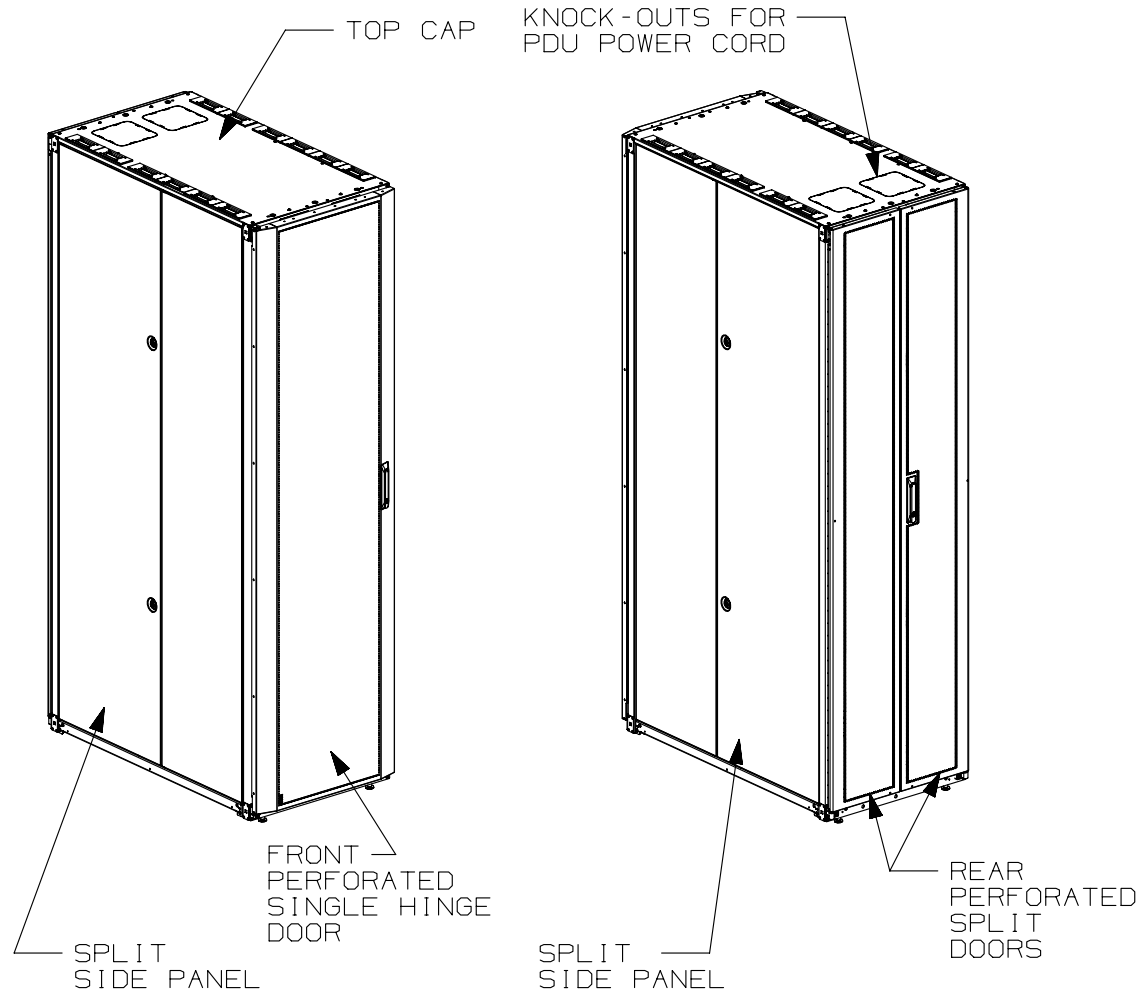

1. VISIT OUR ON-LINE CATALOG AT WWW.PANDUIT.COM FOR A LIST OF CURRENT PARTS APPLICABLE FOR USE WITH THIS PRODUCT.
2. PRIMARY DIMENSIONS ARE IN MILLIMETERS.
3. RAIL ADJUSTMENT MEASUREMENTS ARE TAKEN FROM THE FRONT FACE OF EACH EQUIPMENT RAIL. INDEPENDENT ADJUSTABLE REAR EQUIPMENT MOUNTING RAILS (EIA) ADJUST FROM 65mm [2.6in] TO 357mm [14.05in] AND FROM 521mm [20.5in] TO 765mm [30.1in] WITH PDU BRACKETS AND CABLE MANAGEMENT FINGERS IN PLACE. REMOVING PDU BRACKETS AND OPTIONAL FINGERS INCREASES MAXIMUM E-RAIL SPAN TO 911mm [35.86in].
4. CAN BE USED WITH ANY 19" EIA STANDARD COMPONENT IN ADDITION TO ALL PANDUIT HORIZONTAL CABLE MANAGEMENT AND PATCH PANEL PRODUCTS.
5. EIA UNIVERSAL STANDARD HOLE PROGRESSION ON EQUIPMENT RAILS 15.88mm [.625in], 15.88mm [.625in], 12.70mm [.5in], 15.88mm [.625in], 15.88mm [.625in], 12.7mm [.5in]...ETC.
6. PARTS SUPPLIED:
 - BASE CABINET
 - FRONT PERFORATED SINGLE HINGE DOOR (SEE CHART ON SHEET 2)
 - REAR PERFORATED SPLIT DOOR (SEE CHART ON SHEET 2)
 - EQUIPMENT RAILS FRONT & REAR (SEE CHART ON SHEET 2)
 - PDU BRACKETS (SEE CHART ON SHEET 2)
 - CASTERS (SEE CHART ON SHEET 2)
 - INSTRUCTION SHEET
7. RACK UNIT SPACING NUMERALS ARE CLEARLY PRINTED ON EQUIPMENT MOUNTING RAILS.
8. FULLY BONDED STRUCTURE WHEN ASSEMBLED PER INSTRUCTIONS.
9. STATIC LOAD RATING. 1360 Kg (3000 LBS)
10. ROLLING LOAD RATING. 1133 Kg (2500 LBS)
11. SINGLE POINT GROUND LOCATIONS AT TOP AND BOTTOM OF CABINET.
12. ALL CABINET RAILS ARE INSTALLED NUMBERS UP.
13. MAXIMUM EQUIPMENT DEPTH, 959mm [37.75].

REV	DATE	BY	CHK	APR	DESCRIPTION	ECN
O1A	10-10-14	PBS	ADP	TCN	FLOOR MOUNT DIMENSIONS UPDATED	V09000BX
O0B	5-14-13	PBS	NAGL	JDWE	REVISED CHART	12V305QX-DC
O0A	8-27-12	TKW	JDW	PBD	RELEASED TO PRODUCTION	12V305QX-DC

TITLE		NET-ACCESS S TYPE CABINET 600mm WIDE X 1070mm DEEP FAMILY	
		CUSTOMER DRAWING	
ITEM REVISION NAME		12V305QX/01.PRT	
DATASET FILE NAME		12V305QX_DC/01A.PRT	
		MATERIAL: N/A	
		DRAWING NUMBER: 12V305QX-DC	
DRAWN BY	DATE	CHK	SCALE
TKW	8-27-12	JDW	NONE
		THIRD ANGLE PROJECTION	
		SHT 1 OF 5	
		SIZE A	

THIS COPY IS PROVIDED ON A RESTRICTED BASIS AND IS NOT TO BE USED IN ANY WAY DETRIMENTAL TO THE INTERESTS OF PANDUIT CORP.

PART NO.	DESCRIPTION	SINGLE HINGE FRONT DOOR	SPLIT REAR DOOR	SPLIT SIDE PANEL	FRONT CAGE NUT E-RAIL	REAR CAGE NUT FINGER MGMT E-RAIL	REAR CAGE NUT VERTICAL PATCH E-RAIL	STANDARD PDU BRACKETS	CASTERS	CABLE MGMT FINGERS	CABINET WEIGHT FULLY UNPACKAGED	CABINET WEIGHT SHIPPING WEIGHT
S6212*	NET-ACCESS S-TYPE CABINET 600mm X 42RU X 1070mm DEEP	01	01	02	02	02	00	02	04	00	114 Kg/EACH 253 LBS/EACH	135 Kg/EACH 298 LBS/EACH
S6512*	NET-ACCESS S-TYPE CABINET 600mm X 45RU X 1070mm DEEP	01	01	02	02	02	00	02	04	00	119 Kg/EACH 263 LBS/EACH	139 Kg/EACH 308 LBS/EACH
S6812*	NET-ACCESS S-TYPE CABINET 600mm X 48RU X 1070mm DEEP	01	01	02	02	02	00	02	04	00	123 Kg/EACH 273 LBS/EACH	144 Kg/EACH 318 LBS/EACH
S6219*	NET-ACCESS S-TYPE CABINET 600mm X 42RU X 1070mm DEEP	01	01	00	02	02	00	02	04	00	81 Kg/EACH 180 LBS/EACH	102 Kg/EACH 225 LBS/EACH
S6519*	NET-ACCESS S-TYPE CABINET 600mm X 45RU X 1070mm DEEP	01	01	00	02	02	00	02	04	00	84 Kg/EACH 185 LBS/EACH	104 Kg/EACH 230 LBS/EACH
S6819*	NET-ACCESS S-TYPE CABINET 600mm X 48RU X 1070mm DEEP	01	01	00	02	02	00	02	04	00	86 Kg/EACH 190 LBS/EACH	106 Kg/EACH 235 LBS/EACH
S6212*F	NET-ACCESS S-TYPE CABINET 600mm X 42RU X 1070mm DEEP	01	01	02	02	02	00	02	04	01	115 Kg/EACH 255 LBS/EACH	136 Kg/EACH 300 LBS/EACH
S6512*F	NET-ACCESS S-TYPE CABINET 600mm X 45RU X 1070mm DEEP	01	01	02	02	02	00	02	04	01	120 Kg/EACH 265 LBS/EACH	140 Kg/EACH 310 LBS/EACH
S6812*F	NET-ACCESS S-TYPE CABINET 600mm X 48RU X 1070mm DEEP	01	01	02	02	02	00	02	04	01	125 Kg/EACH 275 LBS/EACH	145 Kg/EACH 320 LBS/EACH
S6219*F	NET-ACCESS S-TYPE CABINET 600mm X 42RU X 1070mm DEEP	01	01	00	02	02	00	02	04	01	82 Kg/EACH 182 LBS/EACH	103 Kg/EACH 227 LBS/EACH
S6519*F	NET-ACCESS S-TYPE CABINET 600mm X 45RU X 1070mm DEEP	01	01	00	02	02	00	02	04	01	85 Kg/EACH 187 LBS/EACH	105 Kg/EACH 232 LBS/EACH
S6819*F	NET-ACCESS S-TYPE CABINET 600mm X 48RU X 1070mm DEEP	01	01	00	02	02	00	02	04	01	87 Kg/EACH 192 LBS/EACH	107 Kg/EACH 237 LBS/EACH
S6212*S	NET-ACCESS S-TYPE CABINET 600mm X 42RU X 1070mm DEEP	00	00	02	02	02	00	02	04	00	90 Kg/EACH 198 LBS/EACH	110 Kg/EACH 243 LBS/EACH
S6512*S	NET-ACCESS S-TYPE CABINET 600mm X 45RU X 1070mm DEEP	00	00	02	02	02	00	02	04	00	94 Kg/EACH 208 LBS/EACH	114 Kg/EACH 253 LBS/EACH
S6812*S	NET-ACCESS S-TYPE CABINET 600mm X 48RU X 1070mm DEEP	00	00	02	02	02	00	02	04	00	99 Kg/EACH 218 LBS/EACH	119 Kg/EACH 263 LBS/EACH
S6219*S	NET-ACCESS S-TYPE CABINET 600mm X 42RU X 1070mm DEEP	00	00	00	02	02	00	02	04	00	57 Kg/EACH 125 LBS/EACH	77 Kg/EACH 170 LBS/EACH
S6519*S	NET-ACCESS S-TYPE CABINET 600mm X 45RU X 1070mm DEEP	00	00	00	02	02	00	02	04	00	59 Kg/EACH 130 LBS/EACH	79 Kg/EACH 175 LBS/EACH
S6819*S	NET-ACCESS S-TYPE CABINET 600mm X 48RU X 1070mm DEEP	00	00	00	02	02	00	02	04	00	61 Kg/EACH 135 LBS/EACH	81 Kg/EACH 180 LBS/EACH

* DENOTES COLOR
"B" = BLACK, "W" = WHITE

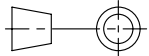
						TITLE NET-ACCESS S TYPE CABINET 600mm WIDE X 1070mm DEEP FAMILY CUSTOMER DRAWING						
						ITEM REVISION NAME 12V305QX/01.PRT						
						DATASET FILE NAME 12V305QX_DC/01A.PRT						
						MATERIAL: N/A						
O1A	10-01-14	PBS	ADP	TCN	SEE SHEET 1 OF 5 FOR REVISIONS	V09000BX	 THIRD ANGLE PROJECTION				DRAWING NUMBER: 12V305QX-DC	
O0B	5-14-13	PBS	NAGL	JDWE	SEE SHEET 1 OF 5 FOR REVISIONS	12V305QX-DC						
O0A	8-27-12	TKW	JDW	PBD	SEE SHEET 1 OF 5 FOR REVISIONS	12V305QX-DC						
REV	DATE	BY	CHK	APR	DESCRIPTION	ECN	DRAWN BY TKW	DATE 8-27-12	CHK JDW	SCALE NONE	SHT 2 OF 5	SIZE A

THIS COPY IS PROVIDED ON A RESTRICTED BASIS AND IS NOT TO BE USED IN ANY WAY DETRIMENTAL TO THE INTERESTS OF PANDUIT CORP.

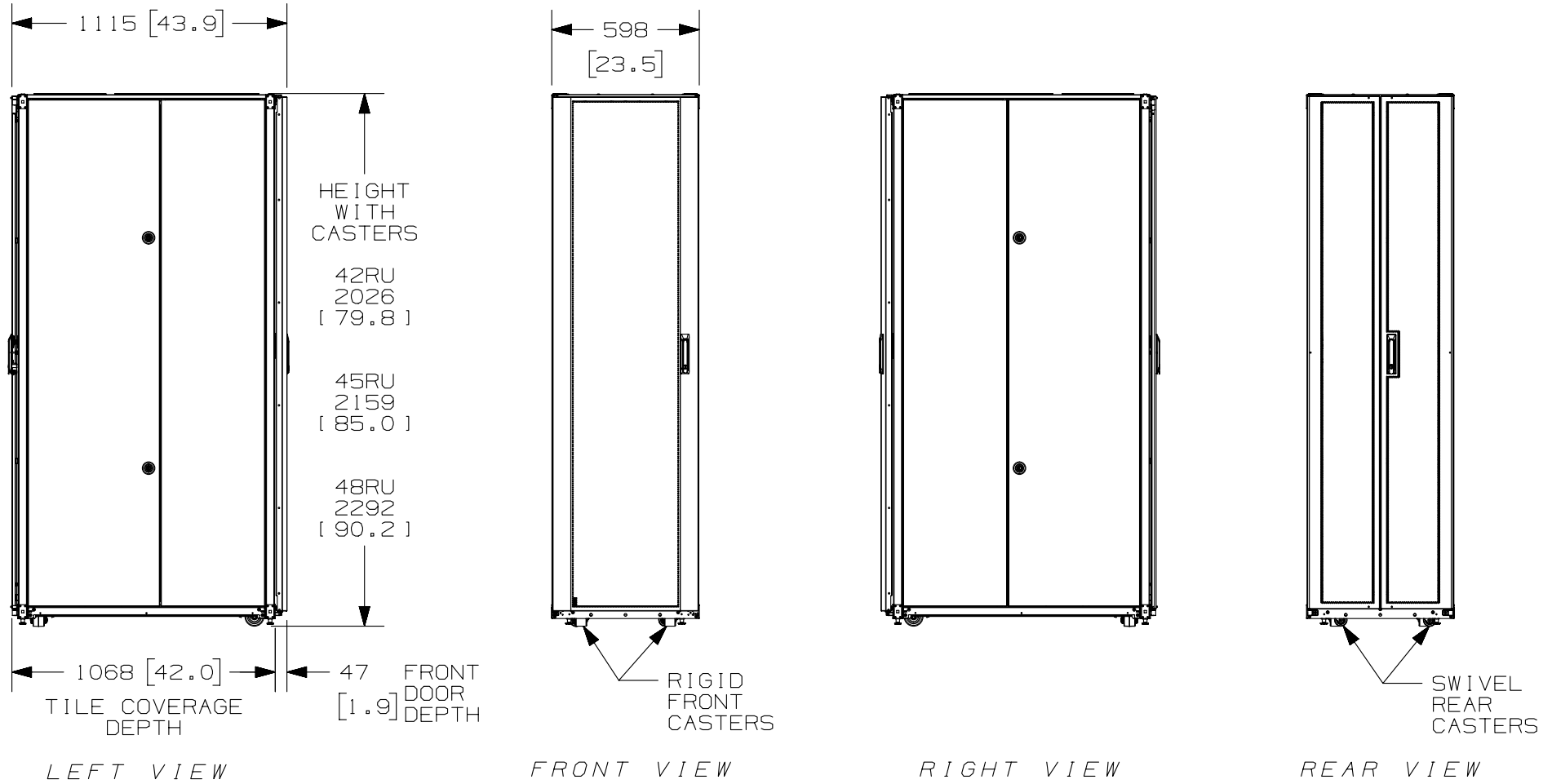

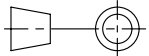
						TITLE		NET-ACCESS S TYPE CABINET 600mm WIDE X 1070mm DEEP FAMILY				
								CUSTOMER DRAWING				
						ITEM REVISION NAME		PANDUIT				
						12V305QX/01.PRT						
						DATASET FILE NAME		MATERIAL:				
						12V305QX_DC/01A.PRT		N/A				
01A	10-01-14	PBS	ADP	TCN	SEE SHEET 1 OF 5 FOR REVISIONS	V09000BX	 THIRD ANGLE PROJECTION					
00B	5-14-13	PBS	NAGL	JDWE	SEE SHEET 1 OF 5 FOR REVISIONS	12V305QX-DC						
00A	8-27-12	TKW	JDW	PBD	SEE SHEET 1 OF 5 FOR REVISIONS	12V305QX-DC						
REV	DATE	BY	CHK	APR	DESCRIPTION	ECN	DRAWN BY	DATE	CHK	SCALE	DRAWING NUMBER:	SIZE
							TKW	8-27-12	JDW	NONE	12V305QX-DC SHT 3 OF 5	A

THIS COPY IS PROVIDED ON A RESTRICTED BASIS AND IS NOT TO BE USED IN ANY WAY DETRIMENTAL TO THE INTERESTS OF PANDUIT CORP.

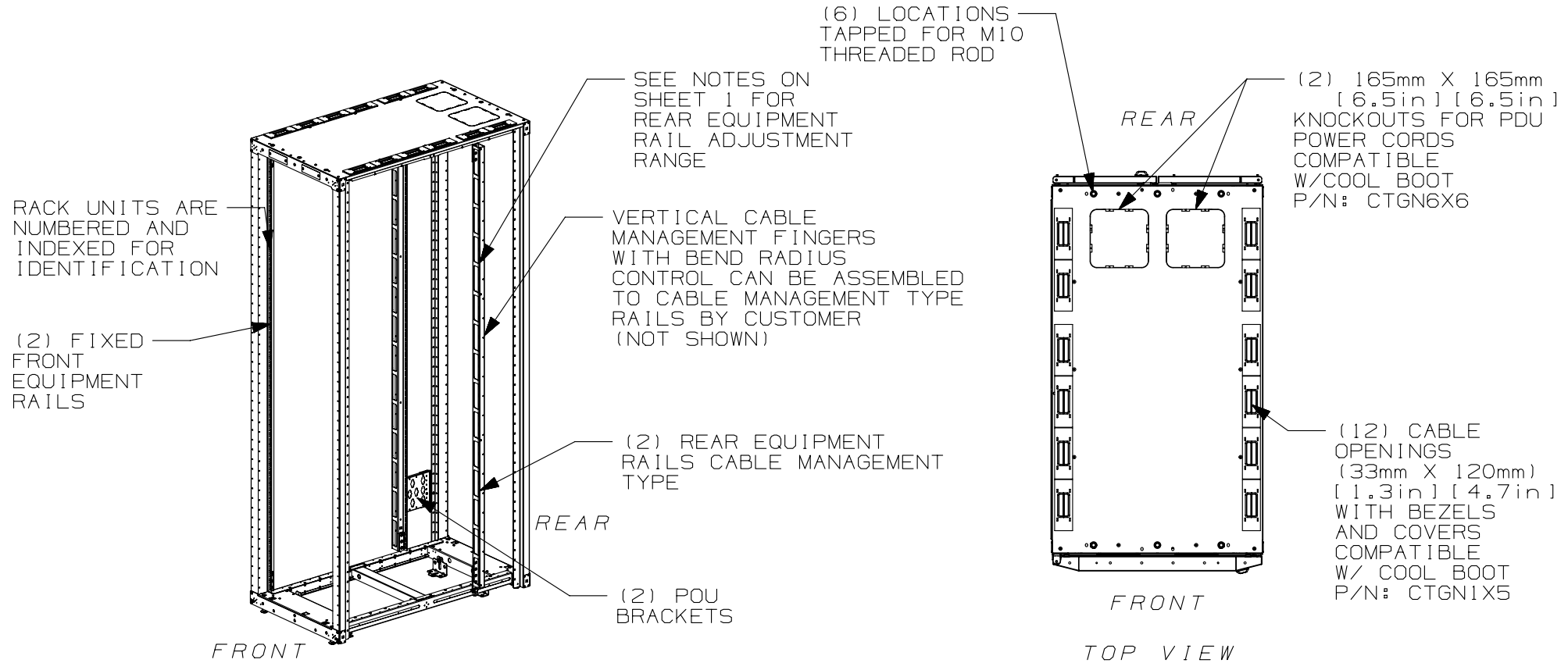

FRONT DOOR, REAR DOOR, AND SIDE PANELS NOT SHOWN

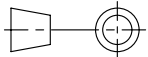
						TITLE NET-ACCESS S TYPE CABINET 600mm WIDE X 1070mm DEEP FAMILY CUSTOMER DRAWING	
						ITEM REVISION NAME 12V305QX/01.PRT	
						DATASET FILE NAME 12V305QX_DC/01A.PRT	
						MATERIAL: N/A	
01A	10-01-14	PBS	ADP	TCN	SEE SHEET 1 OF 5 FOR REVISIONS	V09000BX	 THIRD ANGLE PROJECTION DRAWING NUMBER: 12V305QX-DC
00B	5-14-13	PBS	NAGL	JDWE	SEE SHEET 1 OF 5 FOR REVISIONS	12V305QX-DC	
00A	8-27-12	TKW	JDW	PBD	SEE SHEET 1 OF 5 FOR REVISIONS	12V305QX-DC	
REV	DATE	BY	CHK	APR	DESCRIPTION	ECN	DRAWN BY: TKW DATE: 8-27-12 CHK: JDW SCALE: NONE SHT 4 OF 5 SIZE: A

THIS COPY IS PROVIDED ON A RESTRICTED BASIS AND IS NOT TO BE USED IN ANY WAY DETRIMENTAL TO THE INTERESTS OF PANDUIT CORP.

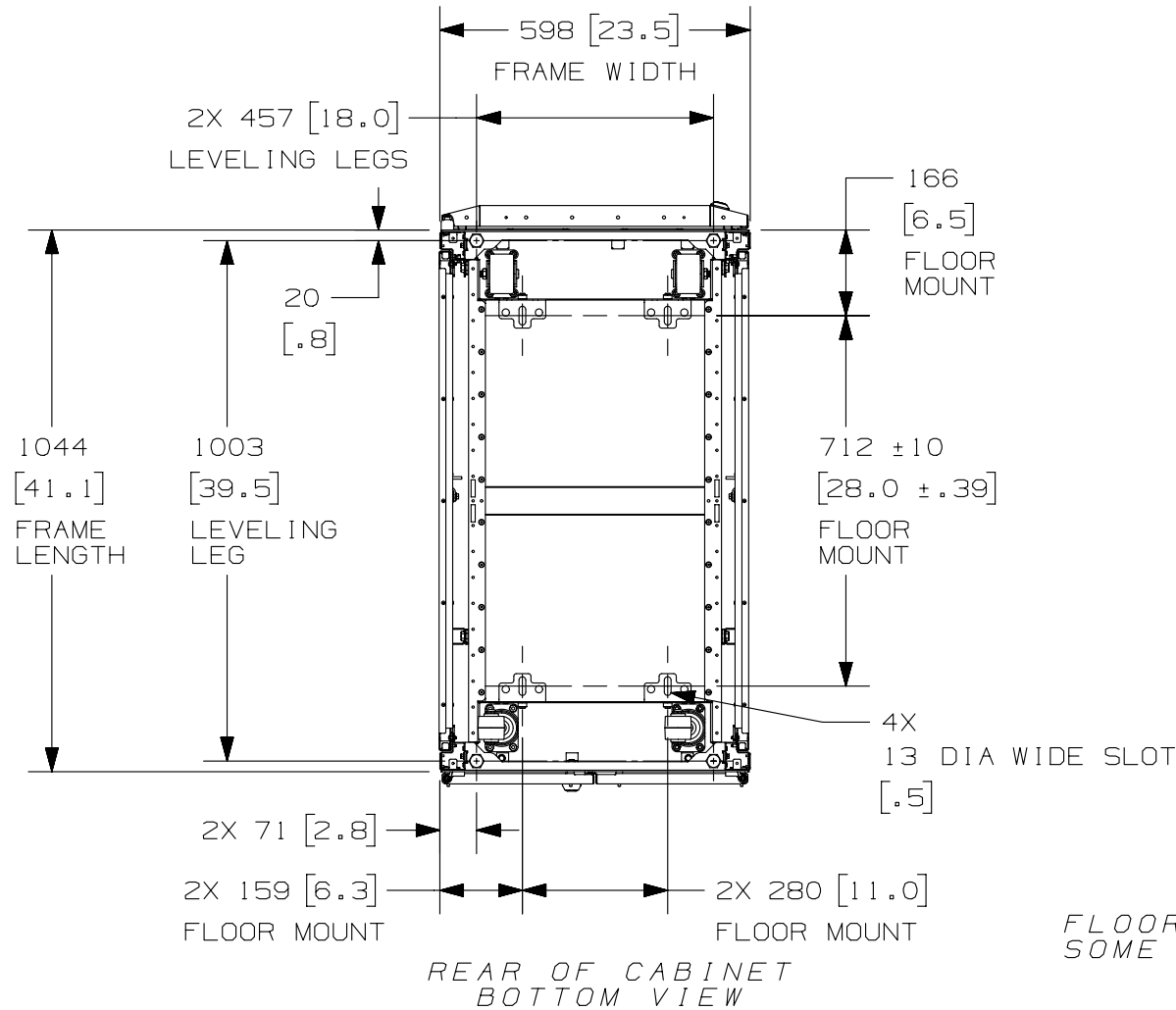

FLOOR MOUNTING HOLE LOCATIONS - SOME PARTS REMOVED FOR CLARITY

REV	DATE	BY	CHK	APR	DESCRIPTION	ECN
O1A	10-01-14	PBS	ADP	TCN	SEE SHEET 1 OF 5 FOR REVISIONS	V09000BX
O0B	5-14-13	PBS	NAGL	JDWE	SEE SHEET 1 OF 5 FOR REVISIONS	12V305QX-DC
O0A	8-27-12	TKW	JDW	PBD	SEE SHEET 1 OF 5 FOR REVISIONS	12V305QX-DC

TITLE		NET-ACCESS S TYPE CABINET 600mm WIDE X 1070mm DEEP FAMILY	
		CUSTOMER DRAWING	
ITEM REVISION NAME		12V305QX/01.PRT	
DATASET FILE NAME		12V305QX_DC/01A.PRT	
			
		MATERIAL: N/A	
		DRAWING NUMBER: 12V305QX-DC	
DRAWN BY		DATE	CHK
TKW	8-27-12	JDW	SCALE
		NONE	
		SHT 5 OF 5	
		SIZE	
		A	

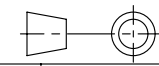

THIRD ANGLE PROJECTION

Данный компонент на территории Российской Федерации

Вы можете приобрести в компании MosChip.

Для оперативного оформления запроса Вам необходимо перейти по данной ссылке:

<http://moschip.ru/get-element>

Вы можете разместить у нас заказ для любого Вашего проекта, будь то серийное производство или разработка единичного прибора.

В нашем ассортименте представлены ведущие мировые производители активных и пассивных электронных компонентов.

Нашей специализацией является поставка электронной компонентной базы двойного назначения, продукции таких производителей как XILINX, Intel (ex.ALTERA), Vicor, Microchip, Texas Instruments, Analog Devices, Mini-Circuits, Amphenol, Glenair.

Сотрудничество с глобальными дистрибьюторами электронных компонентов, предоставляет возможность заказывать и получать с международных складов практически любой перечень компонентов в оптимальные для Вас сроки.

На всех этапах разработки и производства наши партнеры могут получить квалифицированную поддержку опытных инженеров.

Система менеджмента качества компании отвечает требованиям в соответствии с ГОСТ Р ИСО 9001, ГОСТ РВ 0015-002 и ЭС РД 009

Офис по работе с юридическими лицами:

105318, г.Москва, ул.Щербаковская д.3, офис 1107, 1118, ДЦ «Щербаковский»

Телефон: +7 495 668-12-70 (многоканальный)

Факс: +7 495 668-12-70 (доб.304)

E-mail: info@moschip.ru

Skype отдела продаж:

moschip.ru

moschip.ru_4

moschip.ru_6

moschip.ru_9