

Applications

- Base Station Receivers
- Tower Mount Amplifiers
- Balanced Amplifiers
- FDD-LTE, TDD-LTE, WCDMA, CDMA, GSM
- General Purpose Wireless

Product Features

- 0.33 dB NFmin (Single Channel) at 2600 MHz
- 2300–6000 MHz operational bandwidth
- Gain = 18.4 dB at 2600 MHz
- +20.2 dBm Input IP3
- Integrated shut-down biasing feature
- Bias adjustable
- Does not require negative voltage supply
- 4x4 mm 16-pin QFN package

General Description

The TQP3M9041 is a high linearity, ultra low noise figure dual device amplifier in a 4x4 mm package. At 2600 MHz in a balanced configuration, this LNA provides 18.4dB gain, 20.2 dBm IIP3 and 0.8 dB noise figure. The part does not require a negative supply for operation and is bias adjustable for both drain current and voltage. The device is housed in a green/RoHS-compliant industry standard QFN package.

The TQP3M9041 consists of a single monolithic GaAs E-pHEMT die and integrates bias circuitry as well as shut-down capability allowing the LNA to be useful for both FDD and TDD applications.

The TQP3M9041 is optimized for the 2500–2700 MHz band, but can be used outside of the band. TriQuint offers pin-compatible dual LNAs for 500–1500 MHz (TQP3M9039) and 1500–2300 MHz (TQP3M9040). The balanced amplifier is optimized for high performance receivers in wireless infrastructure and can be used for base-station transceivers or tower-mounted amplifiers.



16-pin 4x4 mm QFN Package

Functional Block Diagram

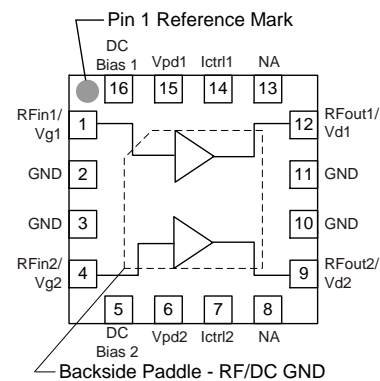

Pin Configuration

Pin No.	Label
1	RFIn1/Vg1
4	RFIn2/Vg2
12	RFout1/Vd1
9	RFout2/Vd2
2, 3, 10, 11	Ground
16	DC Bias 1
5	DC Bias 2
15	Vpd1
6	Vpd2
14	Ictrl1
7	Ictrl2
Backside Paddle	RF/DC GND

Ordering Information

Part No.	Description
TQP3M9041	2300–6000 MHz Dual LNA
TQP3M9041-PCB	2500–2700 MHz Evaluation Board

Standard T/R size = 2500 pieces on a 13" reel

Absolute Maximum Ratings

Parameter	Rating
Storage Temperature	-65 to 150°C
Drain Voltage (V_d)	+7 V
I_d , $V_d = 5V$ (per channel)	300 mA
Input Power (CW)	+22 dBm
Input Power (DC OFF condition)	+22 dBm
Input Power (DC OFF condition & 10% Duty Cycle)	+30 dBm

Operation of this device outside the parameter ranges given above may cause permanent damage.

Recommended Operating Conditions

Parameter	Min	Typ	Max	Units
V_{pd}	0		+5	V
V_g	0	+0.5	+1	V
V_d	+2		+5	V
I_d , per channel		57	80	mA
Operating Temp. Range	-40		+105	°C
T_{ch} (for >10 ⁶ hrs MTTF)			190	°C

Electrical specifications are measured at specified test conditions. Specifications are not guaranteed over all recommended operating conditions.

Electrical Specifications

Test conditions unless otherwise noted: $V_d = +4.35V$, Temp.=+25°C, tuned balanced configuration. The Noise Figure is de-embedded to the input pin of the input hybrid coupler.

Parameter	Conditions	Min	Typ	Max	Units
Operational Frequency Range		2300		6000	MHz
Test Frequency			2600		MHz
Gain		17.2	18.4	19.6	dB
Output P1dB			+22.5		dBm
Input IP3	Pin=-13 dBm/tone, $\Delta f=1$ MHz	+17	+20.2		dBm
Output IP3	Pout=+5 dBm/tone, $\Delta f=1$ MHz		+38.2		dBm
Noise Figure	Balanced Configuration		0.8	1.15	dB
Drain Voltage, V_d			+4.35		V
Drain Current, I_d	Single Channel	35	57	80	mA
Power Down Control Voltage, V_{pd}	On-State	0		+0.3	V
	Off-State	+2.1		V_d	V
Thermal Resistance, θ_{jc}	Junction to case - per channel		53		°C/W

De-embedded S-parameters Data

Test conditions unless otherwise noted: $V_{DD}=+4.35$ V, $I_{DD}=57$ mA, $Temp=+25^{\circ}C$, 50 Ohm system

Freq (MHz)	S11 (dB)	S11 (ang)	S21 (dB)	S21 (ang)	S12 (dB)	S12 (ang)	S22 (dB)	S22 (ang)
10	-0.08	-1.55	31.76	-178.90	-65.61	72.04	-3.83	5.41
100	-0.50	-10.68	32.14	166.28	-52.51	55.96	-1.53	2.04
200	-1.05	-19.42	31.64	151.59	-49.17	66.30	-1.46	-2.87
500	-3.22	-37.41	28.96	121.07	-42.32	70.95	-1.73	-10.88
750	-4.87	-45.81	26.85	104.52	-39.50	69.80	-1.93	-16.10
1000	-6.16	-52.39	25.05	91.86	-37.11	71.15	-2.08	-21.29
1200	-7.06	-57.60	23.85	83.20	-35.62	68.87	-2.22	-25.66
1400	-7.76	-62.48	22.80	75.39	-34.21	67.84	-2.33	-30.17
1600	-8.45	-68.59	21.91	67.93	-32.82	65.63	-2.46	-35.08
1800	-9.08	-74.44	21.10	60.75	-31.80	63.08	-2.59	-40.23
2000	-9.57	-82.20	20.38	53.44	-30.84	60.61	-2.76	-46.28
2200	-9.79	-86.21	19.63	44.72	-30.49	54.60	-3.25	-52.79
2300	-9.82	-84.43	18.95	43.91	-30.09	62.95	-3.09	-51.68
2400	-9.84	-91.72	18.86	41.02	-29.15	59.62	-2.92	-56.18
2500	-9.86	-95.33	18.62	37.63	-28.66	57.75	-2.94	-59.74
2600	-9.98	-99.27	18.33	34.26	-28.31	56.06	-3.06	-62.94
2700	-9.94	-103.51	18.07	31.03	-27.82	54.48	-3.03	-66.14
2800	-9.88	-105.66	17.80	27.96	-27.46	52.93	-3.01	-69.18
3000	-10.07	-111.89	17.30	21.52	-26.72	49.72	-3.10	-75.44
3200	-10.20	-114.68	16.77	15.32	-26.10	46.67	-3.14	-81.16
3400	-9.85	-121.75	16.42	10.10	-25.13	44.73	-3.09	-86.87
3600	-10.15	-126.13	16.07	3.95	-24.62	40.82	-3.18	-92.92
3800	-10.35	-131.51	15.70	-2.03	-23.94	38.08	-3.26	-98.91
4000	-11.47	-137.19	15.37	-6.61	-23.29	36.19	-3.23	-99.29
4250	-11.77	-148.96	15.01	-14.80	-22.49	31.20	-3.43	-107.68
4500	-12.31	-165.19	14.67	-23.65	-21.74	24.83	-3.83	-116.92
4750	-14.33	173.97	14.14	-33.60	-21.58	15.26	-4.72	-126.02
5000	-13.32	-164.72	13.63	-35.01	-21.34	29.91	-3.76	-126.65
5250	-11.33	158.91	13.84	-46.81	-19.30	17.10	-4.12	-145.25
5500	-10.50	136.31	13.58	-57.49	-18.52	8.06	-4.70	-160.18
5750	-9.39	120.64	13.11	-67.85	-17.91	0.21	-5.11	-175.27
6000	-7.88	105.14	12.50	-78.40	-17.38	-8.68	-5.53	168.20

Noise Parameters

Test conditions unless otherwise noted: $V_{DD}=+4.35$ V, $I_{DD}=57$ mA, $Temp=+25^{\circ}C$, 50 Ohm system

Freq (GHz)	NF _{min} (dB)	Γ_{Opt} (mag)	Γ_{Opt} (deg)	Rn (Ω)
2	0.16	0.16	57.92	0.05
2.1	0.21	0.17	71.64	0.05
2.2	0.30	0.20	53.88	0.07
2.3	0.24	0.15	84.16	0.05
2.35	0.27	0.13	97.19	0.05
2.4	0.29	0.13	101.49	0.05
2.5	0.32	0.13	117.86	0.05
2.6	0.33	0.14	113.34	0.04
2.7	0.34	0.12	112.27	0.05
2.8	0.38	0.10	141.65	0.05
2.9	0.38	0.11	153.72	0.05
3	0.53	0.13	-152.67	0.06
3.2	0.64	0.03	89.21	0.06
3.4	0.56	0.09	176.76	0.06
3.6	0.54	0.16	-105.65	0.07
3.8	0.64	0.17	-130.46	0.08
4	0.62	0.16	-127.44	0.06

Noise Figure Circles at 2600 MHz

Noise parameter measurements taken at the package pin reference plane. The gate and drain are biased externally through bias-tees. The achievable NFmin will worsen with on board non-ideal bias circuit.

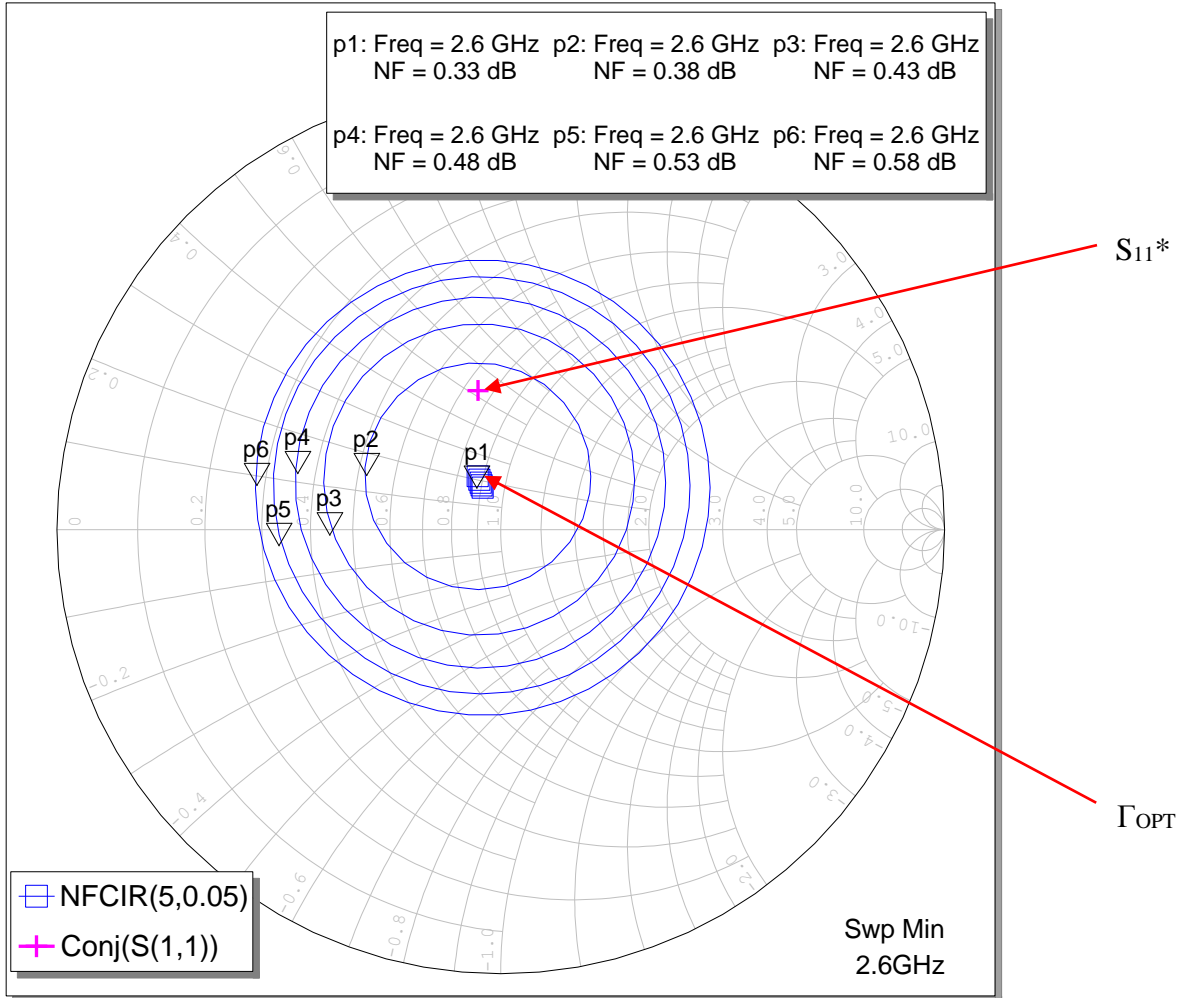

TQP3M9041-PCB Evaluation Board (2500–2700 MHz)

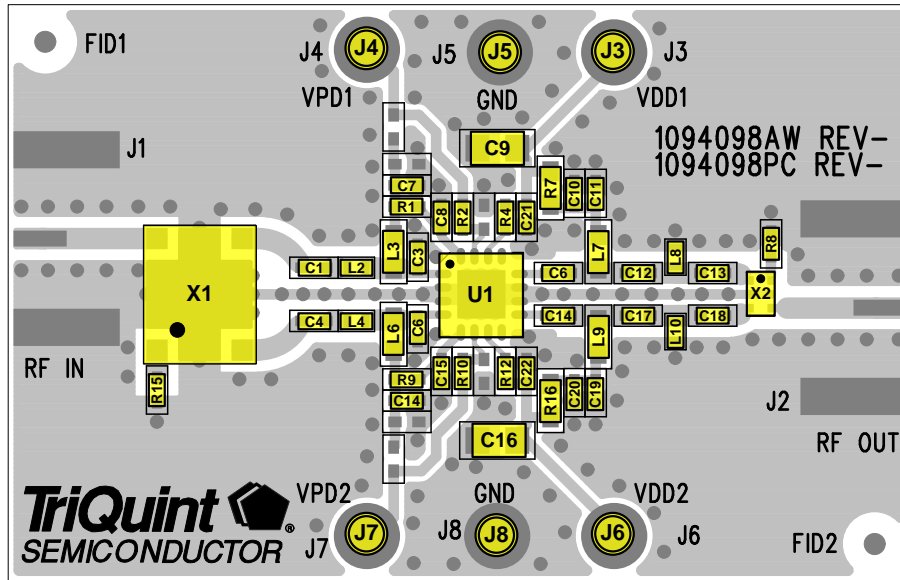

See Evaluation Board PCB Information section for PCB material and stack-up.

Bill of Material – TQP3M9041-PCB

Reference Des.	Value	Description	Manuf.	Part Number
U1	n/a	Dual LNA	TriQuint	TQP3M9041
X1	n/a	Hybrid Coupler	Anaren	X3C26P1-03S
X2	n/a	Hybrid Coupler	Anaren	C2327J5003AHF
R1, R9	330 Ω	RES, 0402, +/-5%, 1/10W	Various	
R8, R15	51 Ω	RES, 0402, +/-5%, 1/10W	Various	
R4, R12	2.7K Ω	RES, 0402, +/-5%, 1/10W	Various	
R7, R16	6.8 Ω	RES, 0603, +/-5%, 1/8W	Various	
R2, R6, R10, R14, L2, L4	0 Ω	RES, 0402, +/-5%, 1/10W	Various	
C1, C4, C7, C14	22 pF	CAP, 0402, +/-5%, 50V	Panasonic	ECJ-0EC1H220J
C11, C19, C21, C22	100 pF	CAP, 0402, +/-5%, 50V	Panasonic	ECJ-0EC1H101J
C9, C16	0.01 uF	CAP, 0805, +/-5%, 50V, X7R	Various	
C10, C20	1000 pF	CAP, 0402, +/-10%, 50V	Various	
C12, C13, C17, C18	1 pF	CAP, 0402, +/-0.05pF, 25V	AVX	04023J1R0ABSTR
L3, L6, L7, L9	47 nH	IND, 0603, +/-5%, 600mA	Coilcraft	0402CS-1N2XJL
L8, L10	2.2 nH	IND, 0402, +/-5%	Coilcraft	0603CS-47NXJL
C3, C6, C8, C15	DNP			

Notes:

1. R2, R6, R10, and R14 may be replaced with metal trace in target applications.
2. L2 and L4, or an equivalent transmission line length, are required for impedance matching.

Application Circuit – TQP3M9041-PCB

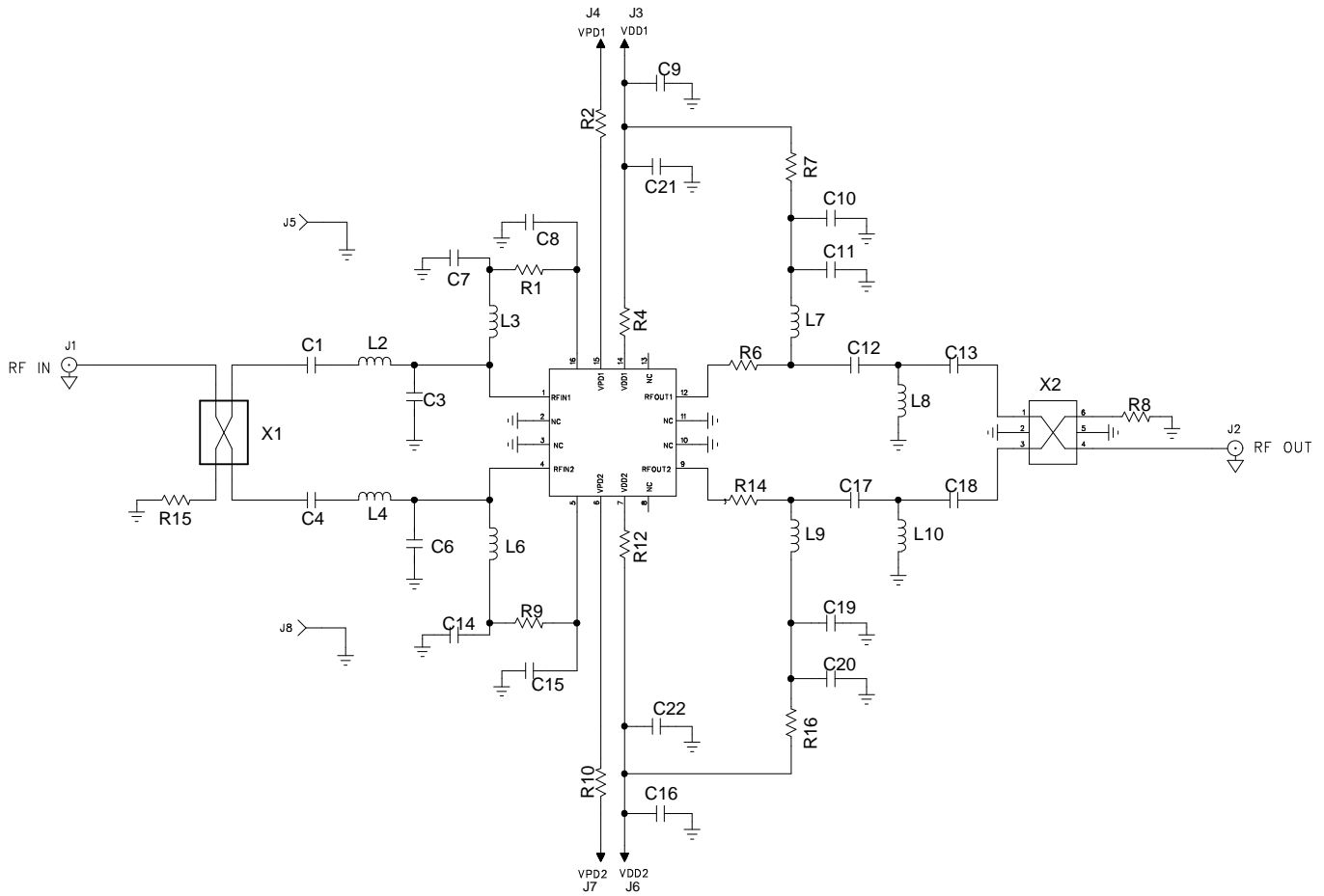

Typical Performance (Balanced Configuration)

Test conditions unless otherwise noted: $V_d = +4.35\text{ V}$, $I_d = 57\text{ mA}$, $\text{Temp.} = +25^\circ\text{C}$. NF is de-embedded to the input pin of the input hybrid coupler.

Parameter	Typical Value			Units
Frequency	2500	2600	2700	MHz
Gain	18.1	18.1	17.7	dB
Noise Figure	0.7	0.77	0.85	dB
Input Return Loss	22	19	18	dB
Output Return Loss	22	29	26	dB
Output P1dB	+22.6	+22.5	+22.5	dBm
IIP3 (Pin/tone = -13 dBm, $\Delta f = 1\text{ MHz}$)	+20.1	+20.2	+20.3	dBm

Performance Plots (Balanced Configuration)

Test conditions unless otherwise noted: $V_d = +4.35\text{ V}$, $I_d = 57\text{ mA}$, $\text{Temp.} = +25^\circ\text{C}$

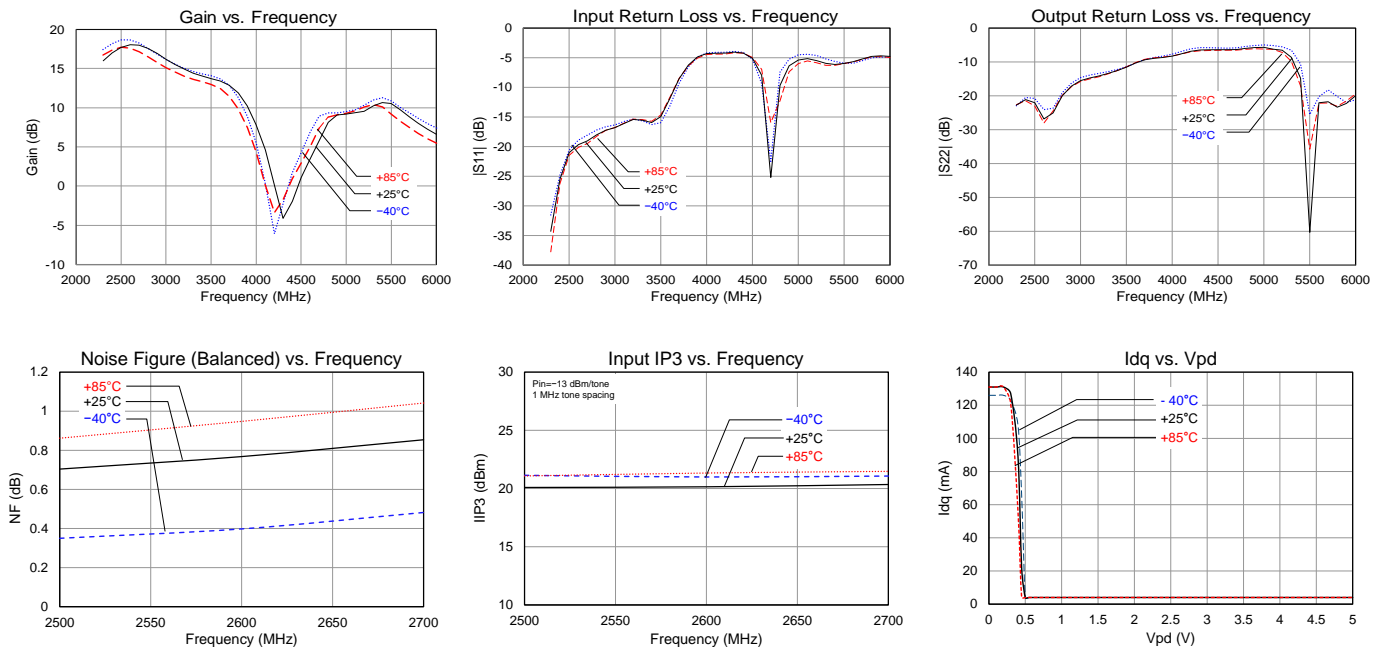

Pin Configuration and Description

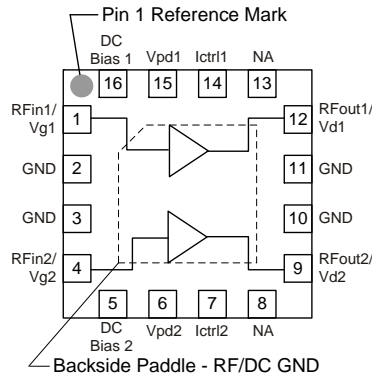

Pin No.	Label	Description
1	RFIn1/Vg1	RF input pin for channel 1. Gate voltage bias pin for channel 1.
2, 3, 10, 11	GND	No internal connection but should be grounded to provide PCB mounting integrity and isolation between the two RF paths.
4	RFIn2/Vg2	RF input pin for channel 2. Gate voltage bias pin for channel 2.
5	DC Bias 2	DC out bias for channel 2
6	Vpd2	Power down control voltage for channel 1
7	Ictrl2	Channel 2 drain current control
8, 13	NA	No internal connection. These pins can be grounded to provide PCB mounting integrity.
9	RFout2/Vd2	RF output pin for channel 2. Gate voltage bias pin for channel 2.
12	RFout1/Vd1	RF output pin for channel 1. Drain voltage bias pin for channel 1.
14	Ictrl1	Channel 1 drain current control
15	Vpd1	Power down control voltage for channel 1
16	DC Bias 1	DC out bias for channel 1
Backside Paddle	RF/DC GND	RF/DC Ground. Follow recommended via pattern and ensure good solder attach for best thermal and electrical performance.

Evaluation Board PCB Information

TriQuint PCB 1094098 Material and Stack-up

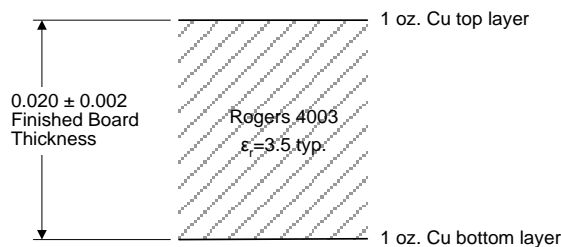

50 ohm line dimensions: width = .040", spacing = .020"

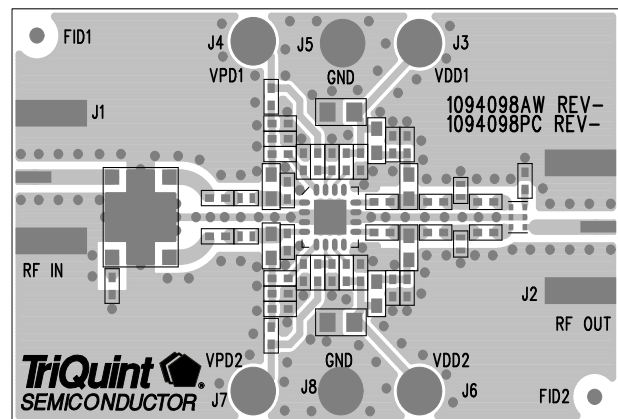

Mechanical Information

Package Marking and Dimensions

Marking: Part number – 3M9041
Year, week - YYWW
Assembly code - AaXXXX

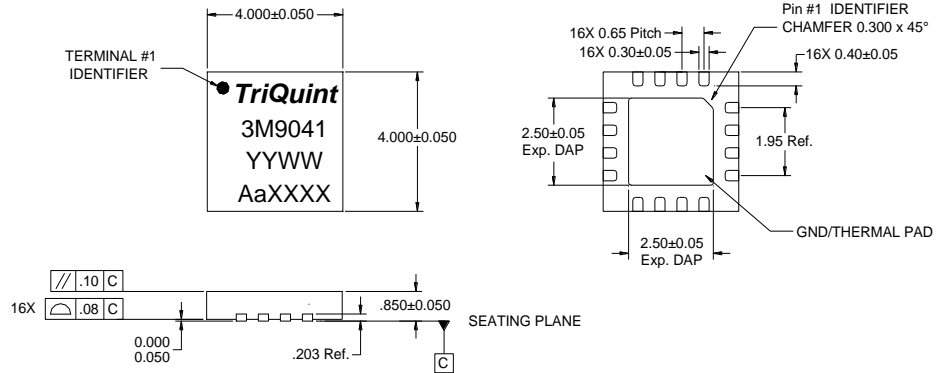

Notes:

1. All dimensions are in millimeters. Angles are in degrees.
2. Except where noted, this part outline conforms to JEDEC standard MO-220, Issue E (Variation VGGC) for thermally enhanced plastic very thin fine pitch quad flat no lead package (QFN).
3. Dimension and tolerance formats conform to ASME Y14.4M-1994.
4. The terminal #1 identifier and terminal numbering conform to JESD 95-1 SPP-012

PCB Mounting Pattern

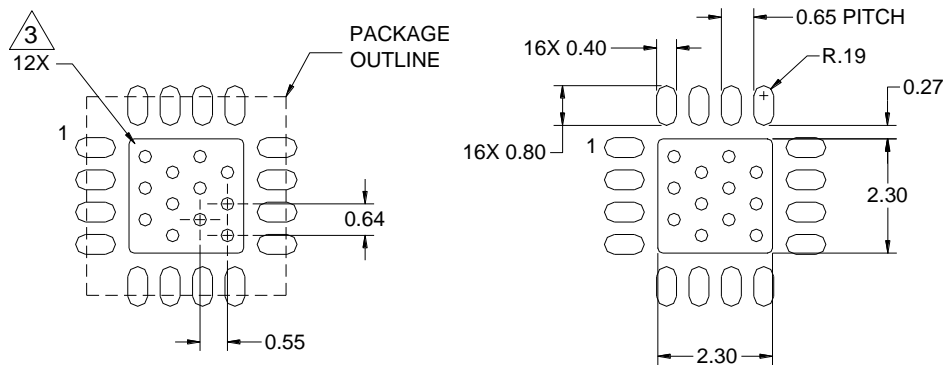

COMPONENT SIDE

Notes:

1. All dimensions are in millimeters. Angles are in degrees.
2. Use 1 oz. copper minimum for top and bottom layer metal.
3. We recommend a 0.35mm (#80/.0135") diameter bit for drilling via holes and a final plated thru diameter of 0.25 mm (0.10").
4. Ensure good package backside paddle solder attach for reliable operation and best electrical performance.

Product Compliance Information

ESD Sensitivity Ratings



Caution! ESD-Sensitive Device

ESD Rating: Class 1A
Value: ≥ 250 V and < 500 V
Test: Human Body Model (HBM)
Standard: JEDEC Standard JESD22-A114

ESD Rating: Class C3
Value: > 1000 V
Test: Charged Device Model (CDM)
Standard: JEDEC Standard JESD22-C101

MSL Rating

MSL Rating: Level 1
Test: 260°C convection reflow
Standard: JEDEC Standard IPC/JEDEC J-STD-020

Solderability

Compatible with both lead-free (260°C max. reflow temperature) and tin/lead (245°C max. reflow temperature) soldering processes.

Package contact plating: NiPdAu

RoHs Compliance

This part is compliant with EU 2002/95/EC RoHS directive (Restrictions on the Use of Certain Hazardous Substances in Electrical and Electronic Equipment).

This product also has the following attributes:

- Lead Free
- Halogen Free (Chlorine, Bromine)
- Antimony Free
- TBBP-A ($\text{C}_{15}\text{H}_{12}\text{Br}_4\text{O}_2$) Free
- PFOS Free
- SVHC Free

Contact Information

For the latest specifications, additional product information, worldwide sales and distribution locations:

Web: www.triquint.com

Tel: 877-800-8584

Email: customer.support@qorvo.com

For information about the merger of RFMD and TriQuint as Qorvo:

Web: www.qorvo.com

For technical questions and application information:

Email: sjcappplications.engineering@qorvo.com

Important Notice

The information contained herein is believed to be reliable. TriQuint makes no warranties regarding the information contained herein. TriQuint assumes no responsibility or liability whatsoever for any of the information contained herein. TriQuint assumes no responsibility or liability whatsoever for the use of the information contained herein. The information contained herein is provided "AS IS, WHERE IS" and with all faults, and the entire risk associated with such information is entirely with the user. All information contained herein is subject to change without notice. Customers should obtain and verify the latest relevant information before placing orders for TriQuint products. The information contained herein or any use of such information does not grant, explicitly or implicitly, to any party any patent rights, licenses, or any other intellectual property rights, whether with regard to such information itself or anything described by such information.

TriQuint products are not warranted or authorized for use as critical components in medical, life-saving, or life-sustaining applications, or other applications where a failure would reasonably be expected to cause severe personal injury or death.

Данный компонент на территории Российской Федерации

Вы можете приобрести в компании MosChip.

Для оперативного оформления запроса Вам необходимо перейти по данной ссылке:

<http://moschip.ru/get-element>

Вы можете разместить у нас заказ для любого Вашего проекта, будь то серийное производство или разработка единичного прибора.

В нашем ассортименте представлены ведущие мировые производители активных и пассивных электронных компонентов.

Нашей специализацией является поставка электронной компонентной базы двойного назначения, продукции таких производителей как XILINX, Intel (ex.ALTERA), Vicor, Microchip, Texas Instruments, Analog Devices, Mini-Circuits, Amphenol, Glenair.

Сотрудничество с глобальными дистрибьюторами электронных компонентов, предоставляет возможность заказывать и получать с международных складов практически любой перечень компонентов в оптимальные для Вас сроки.

На всех этапах разработки и производства наши партнеры могут получить квалифицированную поддержку опытных инженеров.

Система менеджмента качества компании отвечает требованиям в соответствии с ГОСТ Р ИСО 9001, ГОСТ РВ 0015-002 и ЭС РД 009

Офис по работе с юридическими лицами:

105318, г.Москва, ул.Щербаковская д.3, офис 1107, 1118, ДЦ «Щербаковский»

Телефон: +7 495 668-12-70 (многоканальный)

Факс: +7 495 668-12-70 (доб.304)

E-mail: info@moschip.ru

Skype отдела продаж:

moschip.ru

moschip.ru_4

moschip.ru_6

moschip.ru_9