

## S660 Preset Totalizer Counter



File# E199939



- Easily programmed from the front panel
- Remote reset capability
- Input variety:  
    Quadrature, Switch, TTL, CMOS, NAMUR, PNP, NPN
- Software functions include:  
    Password  
    Display Scaling  
    Set Point Programming  
    Decimal Point Selection
- 5A Relay Outputs
- Optional 12DCV Excitation

The S660 is a versatile totalizing counter that can be adapted to a wide variety of counting, measuring and controlling applications.

The control inputs offer several counter operation modes:  
Count/direction, add/add, add/subtract, subtract/subtract, quadrature and reverse quadrature.

Optional relay outputs enhance the counter from a passive device to an integral control element for your application.

# S660 Preset Totalizer Counter

## Ordering Information

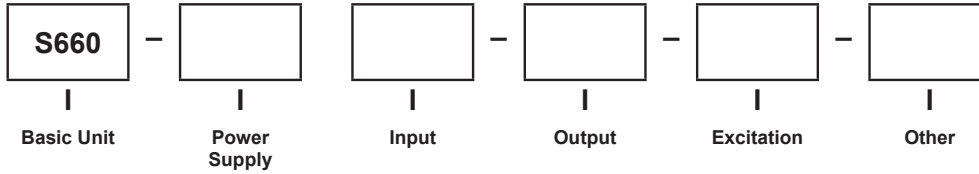

Select From Each One Below		
<b>Basic Unit</b>		
	S660	
<b>Power Supply</b>		
1	120 ACV	
2	240 ACV	
<b>Input</b>		
1	Standard	
2	Quadrature	
<b>Output</b>		
0	None	
1	One Relay	
2	Two Relays	
<b>Excitation</b>		
0	None	
1	12DCV (100mA Max Current)	
<b>Other</b>		
0	None	

<b>Specifications</b>	
<b>DISPLAY</b>	
Type	6-digit, 7-segment, red LED
Height	0.56" (14.2mm)
Decimal Point	User-programmable
Count Direction	"+" indication implied, "-" indication displayed
Display Range	-99,999 to +999,999
Output Indicators	1 and 2
<b>POWER REQUIREMENTS</b>	
AC Voltages	120 or 240VAC, $\pm 10\%$
Power Consumption	3VA
<b>INPUT RATINGS</b>	
Current Sinking	10K $\Omega$ 5% Resistor pull-up to (9.0 - 16DCV) $\pm 10\%$
Current Sourcing	5.1K $\Omega$ 5% Resistor pull-down to common
Minimum Pulse Width	$\sim 5\mu\text{s}$
Low Pass Filter	<200Hz
Low Bias	VLT = 1.6V $\pm 10\%$ VUT = 3.6V $\pm 10\%$
High Bias	VLT = 5.0V $\pm 10\%$ VUT = 7.0V $\pm 10\%$
Count Rate	20KHz (Pulse Max) 5KHz (Quadrature X4 Max)
Maximum Voltage Input A,B, and User	30DCV (Max)
User Input	VLT $\leq 0.9\text{DCV}$ , VUT = 3.15DCV (max) (Display Hold) Display is frozen when the User Input is pulled low
<b>ENVIRONMENTAL</b>	
Operating Temperature	0°C to +40°C
Storage Temperature	-10°C to +60°C
Relative Humidity	0 to 80% non-condensing for temperatures less than 32°C, decreasing linearly to 50% at 40°C
Ambient Temperature	25°C
Temp. Coefficient (per °C)	$\pm 100\text{ppm}/^\circ\text{C}$
Warm-up Time	15 minutes
<b>MECHANICAL</b>	
Bezel	3.93" x 2.04" x .52" (99.8mm x 51.8mm x 13.2mm)
Depth	3.24" (82.3mm)
Panel Cutout	3.62" x 1.77" (92mm x 45mm)
Case Material	PBT-ABS
Weight	9oz (255.1g)

## S660 Preset Totalizer Counter

### Mounting Requirements -

The S660 series 1/8 DIN counters require a panel cutout of 1.77" (45mm) high by 3.62" (92mm) wide.

To install the counter into a panel cutout, remove the clips from the side of the meter.

Slide the meter through your panel cutout, then slide the mounting clips back on the meter.

Press evenly to ensure a proper fit.

### Dimensions

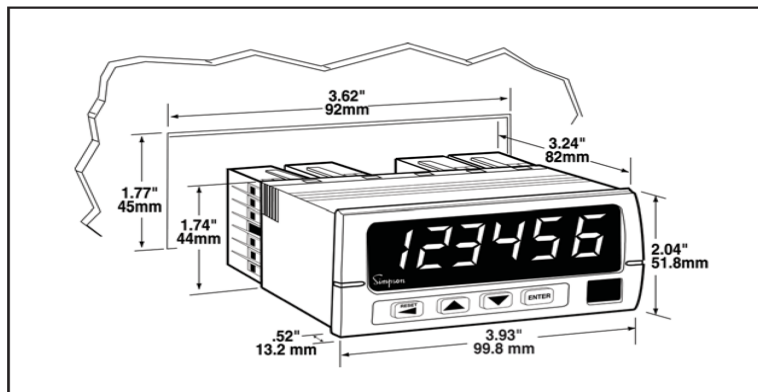

## S660 Preset Totalizer Counter

### Accessories available for the S660



#### Chariot

The Chariot is used to mount most cube-style quadrature encoders and measuring wheels. Made of anodized aluminum, the chariot includes mounting hardware and selectable pivotal points. Wheels, tires, and flexible shaft couplings are sold separately.

**Catalog No. 46012**

#### Flexible Shaft Couplings

The one-piece flexible coupling connects the shaft of a cube-style encoder to an ancillary equipment shaft without worry of misalignment of rotary frequency. The coupling ensures minimum windup, minimum rotary oscillation, and no hysteresis.

**Coupling:** For connecting an encoder to a 3/8" shaft. **Catalog No. 46002**

**Coupling package:** For connecting an encoder to 1/4" or 5/16" diameter shaft.

Package includes: One flexible coupling (1/2" I.D.) and three reducing inserts (1/4", 5/16", 3/8").

**Catalog No. 46003**



#### Tire Durometer

A Simpson 12" circumference anodized aluminum measuring wheel is the right choice to complete the setup of a length measurement system.

Whether the application requires one or two, Simpson's measuring wheels will perform accurately and reliably throughout the measuring process.

Also included on the measuring wheel is a printed alignment scale which assists in the installation and measurement of the length measurement system.

Simpson offers four replaceable durometer tires that consist of a black tire that has a longer life span and three non marking tires. The three non marking tires are for delicate materials such as plastics, textiles, wood, metal and paper to prevent tearing, damage or marking of delicate materials.

80A, black tire; longer service life for plastics, metals. **Catalog No. 46004**

83A, non-marking tire for textiles, medium textures. **Catalog No. 46005**

92A, non-marking tire for plastics, metals, coarse wood. **Catalog No. 46006**

70A, non-marking tire for soft textiles. **Catalog No. 46007**

5 Feet Cable Assembly **Catalog No. 46013**

10 Feet Cable Assembly **Catalog No. 46014**

15 Feet Cable Assembly **Catalog No. 46015**

## Данный компонент на территории Российской Федерации

### Вы можете приобрести в компании MosChip.

Для оперативного оформления запроса Вам необходимо перейти по данной ссылке:

<http://moschip.ru/get-element>

Вы можете разместить у нас заказ для любого Вашего проекта, будь то серийное производство или разработка единичного прибора.

В нашем ассортименте представлены ведущие мировые производители активных и пассивных электронных компонентов.

Нашей специализацией является поставка электронной компонентной базы двойного назначения, продукции таких производителей как XILINX, Intel (ex.ALTERA), Vicor, Microchip, Texas Instruments, Analog Devices, Mini-Circuits, Amphenol, Glenair.

Сотрудничество с глобальными дистрибьюторами электронных компонентов, предоставляет возможность заказывать и получать с международных складов практически любой перечень компонентов в оптимальные для Вас сроки.

На всех этапах разработки и производства наши партнеры могут получить квалифицированную поддержку опытных инженеров.

Система менеджмента качества компании отвечает требованиям в соответствии с ГОСТ Р ИСО 9001, ГОСТ РВ 0015-002 и ЭС РД 009

### Офис по работе с юридическими лицами:

105318, г.Москва, ул.Щербаковская д.3, офис 1107, 1118, ДЦ «Щербаковский»

Телефон: +7 495 668-12-70 (многоканальный)

Факс: +7 495 668-12-70 (доб.304)

E-mail: [info@moschip.ru](mailto:info@moschip.ru)

Skype отдела продаж:

moschip.ru

moschip.ru\_4

moschip.ru\_6

moschip.ru\_9