

High Efficiency 2-Channel LED Backlight with Flash Function

Features

- Wide input range: 2.7V~5.5V
- High efficiency step-up 2-Channel LED driver
- 2-Ch current sinks, up to 8-LEDs per string
 - ▶ Up to 29.8mA/Ch in backlight mode and up to 59.6mA/Ch in flash mode
 - ▶ +/-0.6% current matching at 20.2mA
 - ▶ +/-1.5% current accuracy at 20.2mA
- I²C/PWM dual dimming control scheme
 - ▶ 11-bit I²C exponential or linear mapping with programmable transition ramp time
 - ▶ Wide range PWM dimming with programable transition ramp time
 - 100Hz to 100kHz frequency
 - 0.2% to 100% duty cycle at 20kHz
- Programmable current sink turn on/off ramp time and shape
- Selectable boost converter switching frequency 1MHz or 500kHz with 20% shift up option
- Programmable input PWM hysteresis to minimize jitter at low PWM duty cycle
- Programmable OVP (25.9V/32V) and current limit (2.6A/1.8A)
- Programmable flash current and timeout
- LED open/short protection
- Status reporting through I²C interface

Applications

- Smartphone/Tablet Backlight and Selfie Flash

Brief Description

KTD3134 is the ideal power solution for LED backlighting and selfie flash in medium to large size LCD panels. It is a highly integrated step-up DC-DC converter operating with an input voltage from 2.7V to 5.5V, accommodating 1-cell lithium ion batteries or 5V supply. It includes a high voltage power NMOS, as well as two current sinks, resulting in a simpler and smaller solution with fewer external components. High switching frequency allows the use of a smaller inductor and capacitor.

Each of the two regulated current sinks can regulate up to 29.8mA in backlight mode. With a maximum of 32V at the output of the step-up converter, each string can connect up to 8-LED in series for a 16-LED application.

KTD3134 is equipped with I²C interface for various controls. For additional flexibility, PWM dimming with wide range frequency and duty cycle is included to support Content Adaptive Brightness Control (CABC).

KTD3134 also adds selfie flash function to the existing backlight solution by boosting the sink current up to 59.6mA/Ch and integrating a flash timeout of up to 1.5sec.

Various protection features are built into KTD3134, including cycle-by-cycle inductor current limit protection, output over-voltage protection, LED fault (open or short) protection and thermal shutdown protection.

KTD3134 is available in a RoHS compliant 12-ball 1.19mm x 1.64mm WLCSP or a 16-lead 3mm x 3mm x 0.75mm Thin-QFN package.

Typical Application

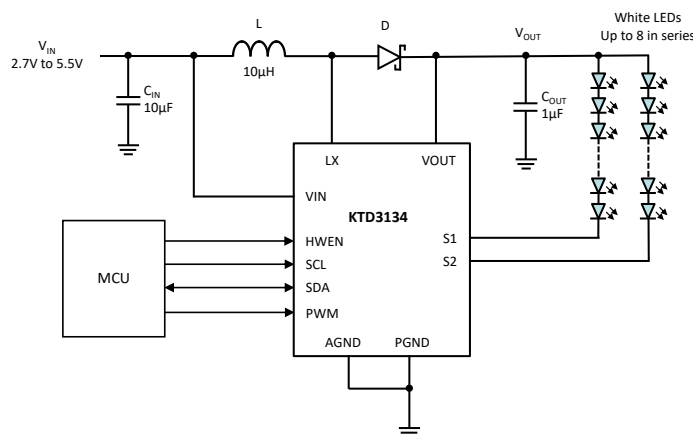



Ordering Information

Part Number	Marking ¹	Operating Temperature	Package
KTD3134EUS-TR	LIXXYYZZZZ	-40°C to +85°C	WLCSP-12
KTD3134EFJ-TR	LIYYZ	-40°C to +85°C	TQFN33-16

1. "XXYYZZZZ" / "YYZ" are the date code, assembly code and serial number / the date code and assembly code

Kinetic Technologies cannot assume responsibility for use of any circuitry other than circuitry entirely embodied in a Kinetic Technologies product. No intellectual property or circuit patent licenses are implied. Kinetic Technologies reserves the right to change the circuitry and specifications without notice at any time.

Данный компонент на территории Российской Федерации

Вы можете приобрести в компании MosChip.

Для оперативного оформления запроса Вам необходимо перейти по данной ссылке:

<http://moschip.ru/get-element>

Вы можете разместить у нас заказ для любого Вашего проекта, будь то серийное производство или разработка единичного прибора.

В нашем ассортименте представлены ведущие мировые производители активных и пассивных электронных компонентов.

Нашей специализацией является поставка электронной компонентной базы двойного назначения, продукции таких производителей как XILINX, Intel (ex.ALTERA), Vicor, Microchip, Texas Instruments, Analog Devices, Mini-Circuits, Amphenol, Glenair.

Сотрудничество с глобальными дистрибьюторами электронных компонентов, предоставляет возможность заказывать и получать с международных складов практически любой перечень компонентов в оптимальные для Вас сроки.

На всех этапах разработки и производства наши партнеры могут получить квалифицированную поддержку опытных инженеров.

Система менеджмента качества компании отвечает требованиям в соответствии с ГОСТ Р ИСО 9001, ГОСТ РВ 0015-002 и ЭС РД 009

Офис по работе с юридическими лицами:

105318, г.Москва, ул.Щербаковская д.3, офис 1107, 1118, ДЦ «Щербаковский»

Телефон: +7 495 668-12-70 (многоканальный)

Факс: +7 495 668-12-70 (доб.304)

E-mail: info@moschip.ru

Skype отдела продаж:

moschip.ru

moschip.ru_4

moschip.ru_6

moschip.ru_9