

DESCRIPTION

Demonstration circuit 637 features the LT[®]3465 and LT[®]3465A constant-current white LED drivers in small SOT23 ThinSOT packages. The demo board is designed to demonstrate high efficiency and small size performance of the LT3465 and LT3465A, made possible by a 200mV feedback voltage, 1.2MHz (2.4MHz for LT3465A) switching frequency, and a special internal compensation network allowing 0603 input/output capacitors (the output capacitor at 0.22uF). The DC637 is specifically designed for white LED backlight applications using 2~4 LEDs, making

the LT3465 an ideal solution for battery powered portable applications such as cellular phone, digital camera, MP3 player, GPS receiver, and handheld computer (PDAs). LT3465 offers numerous LED-dimming circuit options, see the datasheet for more detailed information on LED brightness control.

Design files for this circuit board are available. Call the LTC factory.

LT is a registered trademark of Linear Technology Corporation

Table 1. Performance Summary (T_A = 25°C)

PARAMETER FOR LED DRIVER	CONDITION	VALUE
Output Voltage	V _{IN} = 2.7V ~ 5V	~13V
Typical Output Ripple	V _{IN} = 3.6V, I _{LED} = 15mA	~30mV
Typical Efficiency	V _{IN} = 3.6V, I _{LED} = 15mA	80%

QUICK START PROCEDURE

DC637 is easily set up for evaluating the LT3465 and LT3465A low noise constant-current step-up LED driver circuit. Follow the test procedure outlined below and see Figure1.

1. There are two LED driver circuits on DC637. The two circuits are named “Efficiency” and “Size”. Placing the JP2 jumper to “Efficiency” enables the more efficient LT3465 circuit and placing JP2 jumper to “Size” enables the smaller LT3465A circuit. Place the JP2 jumper on “Efficiency” to test the LT3465 circuit. If you want to test “Size” circuit, go to step 6.
2. The demo circuit can be powered from a 3V Lithium battery installed on the demo board (BT1) or other input source (bench top power supply) by selecting input source jumper (JP1). For battery (BT1) input operation, place the jumper (JP1) to “BATTERY” position and go to step 4.
3. For bench supply input, place the jumper (JP1) in the “Vin” position and connect a

3.3V, 500mA bench supply to the Vin and Gnd terminals.

4. Turn on the input power supply or connect the single cell Li-Ion battery. Turn on the LT3465 LED driver circuit by pressing SW1. Observe all four white LEDs light up with uniform brightness. The output voltage should measure about 13V across the “Vout Test” terminal to “Gnd” terminal.
5. The led brightness is controlled by the DC voltage at the CTRL terminal. The typical DC voltage range recommended for dimming is 200mV~ 1.5V. See the LT3465 data sheet for more information on CTRL dimming control.
6. Place the jumper on “Size” to test the LT3465A circuit.
7. The demo board can be powered from a 3V Lithium battery installed on the demo board (BT1) or other input source (bench top power supply) by selecting input source jumper

QUICK START GUIDE FOR DEMONSTRATION CIRCUIT 637

SINGLE CELL WHITE LED (4) DRIVER

- (JP1). For battery (BT1) input operation, place the jumper (JP1) to “BATTERY” position and go to step 9.
- For bench supply input, place the jumper (JP1) in the “Vin” position and connect a 3.3V, 500mA bench supply to the Vin and Gnd terminals.
 - Turn on the input power supply or connect the single cell Li-Ion battery. Turn on the LT3465A LED driver circuit by pressing SW2. Observe all four white LEDs light up with uniform brightness. The output voltage should measure about 13V across the “Vout Test” terminal to “Gnd” terminal.
 - The LED brightness is controlled by a PWM signal at the CTRL terminal. The typical frequency range recommended for PWM dimming is 1kHz~10kHz with a signal magnitude of 2V. See the LT3465A data sheet for more information on CTRL dimming control.

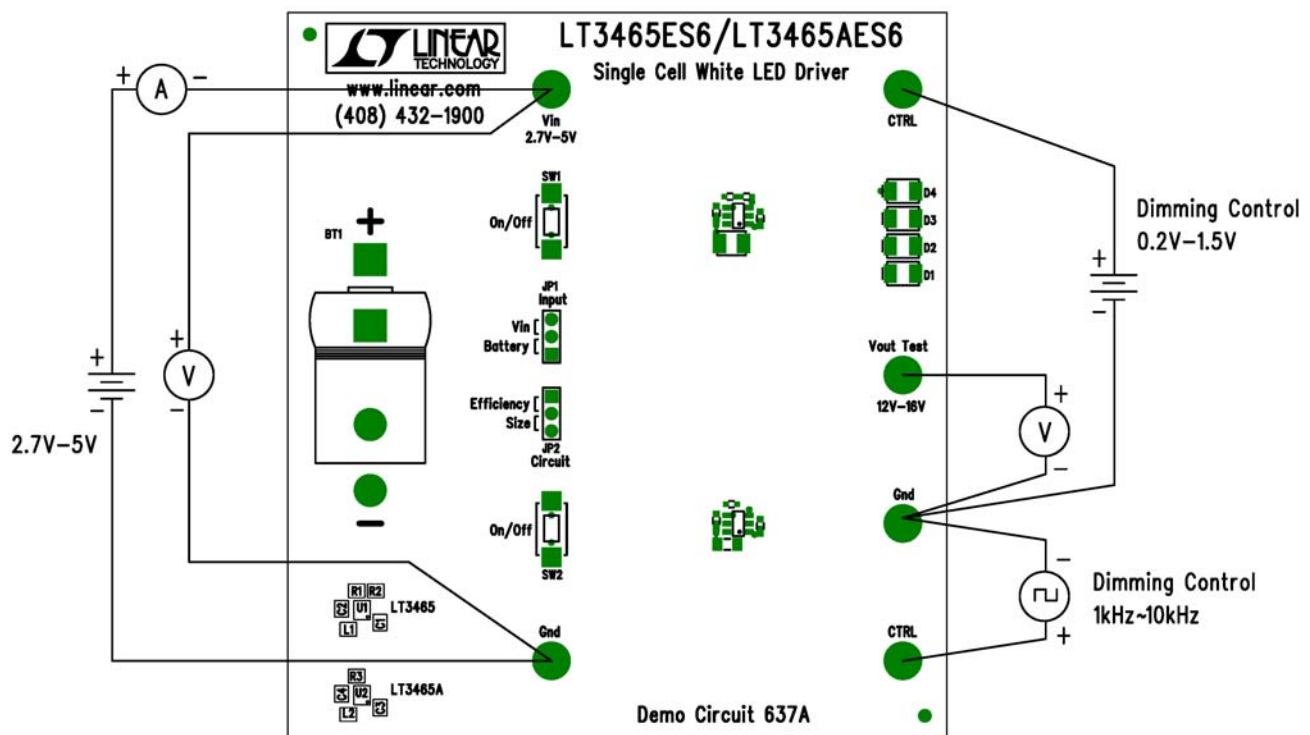

Figure 1. Proper Measurement Equipment Setup

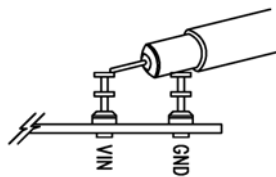
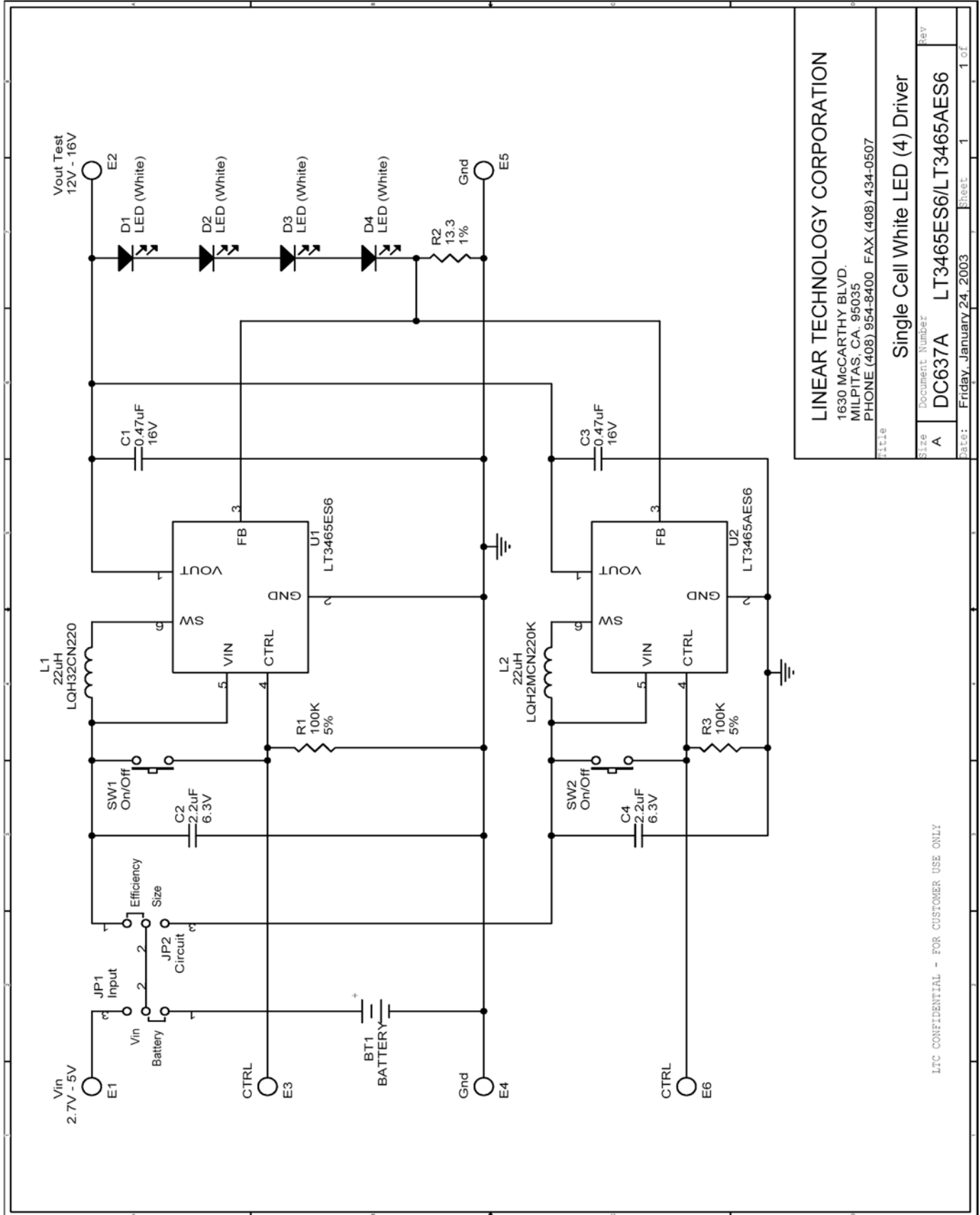

Figure 2. Scope Probe Placement for Measuring Input or Output Ripple

QUICK START GUIDE FOR DEMONSTRATION CIRCUIT 637

SINGLE CELL WHITE LED (4) DRIVER



LINEAR TECHNOLOGY CORPORATION
 1630 McCARTHY BLVD.
 MILPITAS, CA, 95035
 PHONE (408) 954-8400 FAX (408) 434-0507

Title		Single Cell White LED (4) Driver	
Size	Document Number	Rev	
A	DC637A	LT3465ES6/LT3465AES6	
Date:	Friday, January 24, 2003	Sheet	1 of 1

LTC CONFIDENTIAL - FOR CUSTOMER USE ONLY

QUICK START GUIDE FOR DEMONSTRATION CIRCUIT 637

SINGLE CELL WHITE LED (4) DRIVER

Данный компонент на территории Российской Федерации

Вы можете приобрести в компании MosChip.

Для оперативного оформления запроса Вам необходимо перейти по данной ссылке:

<http://moschip.ru/get-element>

Вы можете разместить у нас заказ для любого Вашего проекта, будь то серийное производство или разработка единичного прибора.

В нашем ассортименте представлены ведущие мировые производители активных и пассивных электронных компонентов.

Нашей специализацией является поставка электронной компонентной базы двойного назначения, продукции таких производителей как XILINX, Intel (ex.ALTERA), Vicor, Microchip, Texas Instruments, Analog Devices, Mini-Circuits, Amphenol, Glenair.

Сотрудничество с глобальными дистрибьюторами электронных компонентов, предоставляет возможность заказывать и получать с международных складов практически любой перечень компонентов в оптимальные для Вас сроки.

На всех этапах разработки и производства наши партнеры могут получить квалифицированную поддержку опытных инженеров.

Система менеджмента качества компании отвечает требованиям в соответствии с ГОСТ Р ИСО 9001, ГОСТ РВ 0015-002 и ЭС РД 009

Офис по работе с юридическими лицами:

105318, г.Москва, ул.Щербаковская д.3, офис 1107, 1118, ДЦ «Щербаковский»

Телефон: +7 495 668-12-70 (многоканальный)

Факс: +7 495 668-12-70 (доб.304)

E-mail: info@moschip.ru

Skype отдела продаж:

moschip.ru

moschip.ru_4

moschip.ru_6

moschip.ru_9