

CSLT Series

Miniature, Open-Loop Current Sensors



DESCRIPTION

Honeywell's CSLT Series miniature, open-loop current sensors incorporate our SS490 Series miniature ratiometric linear Hall-effect sensor (MRL™). The sensing element is encapsulated in a printed circuit board-mountable plastic package.

FEATURES

- Open-loop, through-hole design
- Output voltage isolation from input
- ac or dc current sensing
- Linear ratiometric output
- Current sinking or sourcing output for interfacing flexibility
- Fast response time
- Compact size
- Accurate, low-cost sensing
- Minimum energy dissipation
- Maximum current limited only by conductor size
- Built-in temperature compensation promotes reliable operation
- Operating temperature range -25 °C to 100 °C [-13 °F to 212 °F]
- RoHs compliant (lead-free)

The combination of sensor, flux collector and housing comprises the current sensor assembly. These sensors are ratiometric.

POTENTIAL APPLICATIONS

- Motor control in appliances, HVAC and consumer tools
- Current monitoring of electronic circuits
- Overcurrent protection
- Ground fault detectors
- Robotics
- Industrial process control
- UPS and telecommunication power supplies
- Welding current monitoring
- Battery management systems in mobile equipment
- Watt meters
- Variable speed drives

CSLT Series

PRODUCT SPECIFICATIONS

Product type	miniature hall-effect linear open-loop current sensor
Package quantity/type	25 per box
Package style	PC board mount – radial lead IC
Supply voltage	4.5 Vdc to 10.5 Vdc
Output type	sink/source
Magnetic actuation type	analog ratiometric

Parameter	Symbol	Min.	Typ.	Max.	Units	Condition
Current range	I_p	±100	—	—	AT	<±1.5 % error (-25 °C to 100 °C [-13 °F to 212 °F])
Supply voltage	V_s	4.5	5	10.5	V	—
V_{out} @ 0 NI	V_o	2.35	2.5	2.65	V	—
Supply current	I_s	—	7	9	mA	no load
Sensitivity	$\Delta V/I$	13.5	16	18.5	mV/AT	-25 °C to 100 °C [-13 °F to 212 °F]
Hysteresis	—	—	—	0.5	%	±100 A
Temp error - null	$TC_{\Delta V_o/V_o}$	-0.064	—	0.064	%/°C	—
Temp error - gain	TC_G	-0.03	—	0.12	%/°C	-25 °C to 100 °C [-13 °F to 212 °F]
Rise time	t_r	—	3	—	µs	0 A to 2.0 A

BLOCK DIAGRAM

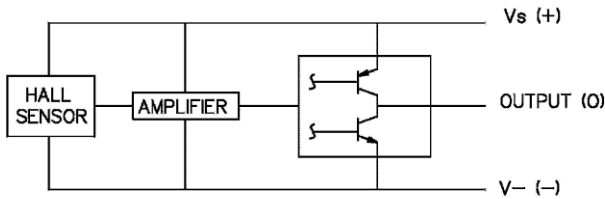

CSLT6B100 TYPICAL TRANSFER FUNCTION [25 °C]

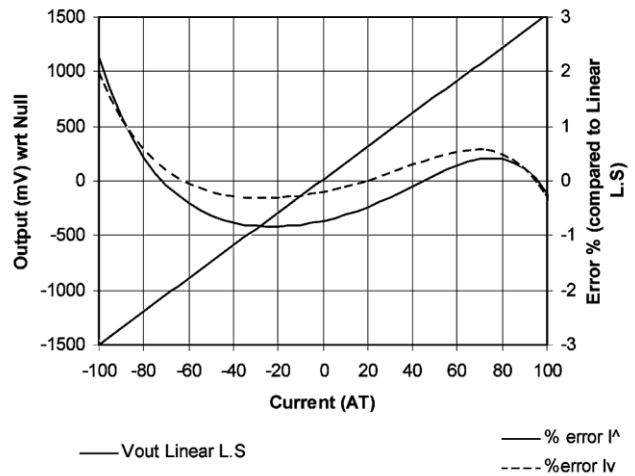

WARNING

PERSONAL INJURY

DO NOT USE these products as safety or emergency stop devices or in any other application where failure of the product could result in personal injury.

Failure to comply with these instructions could result in death or serious injury.

WARRANTY/REMEDY

Honeywell warrants goods of its manufacture as being free of defective materials and faulty workmanship. Honeywell's standard product warranty applies unless agreed to otherwise by Honeywell in writing; please refer to your order acknowledgement or consult your local sales office for specific warranty details. If warranted goods are returned to Honeywell during the period of coverage, Honeywell will repair or replace, at its option, without charge those items it finds defective. **The foregoing is buyer's sole remedy and is in lieu of all other warranties, expressed or implied, including those of merchantability and fitness for a particular purpose. In no event shall Honeywell be liable for consequential, special, or indirect damages.**

While we provide application assistance personally, through our literature and the Honeywell web site, it is up to the customer to determine the suitability of the product in the application.

Specifications may change without notice. The information we supply is believed to be accurate and reliable as of this printing. However, we assume no responsibility for its use.

WARNING

MISUSE OF DOCUMENTATION

- The information presented in this product sheet is for reference only. Do not use this document as a product installation guide.
- Complete installation, operation, and maintenance information is provided in the instructions supplied with each product.

Failure to comply with these instructions could result in death or serious injury.

SALES AND SERVICE

Honeywell serves its customers through a worldwide network of sales offices, representatives and distributors. For application assistance, current specifications, pricing or name of the nearest Authorized Distributor, contact your local sales office or:

E-mail: info.sc@honeywell.com

Internet: www.honeywell.com/sensing

Phone and Fax:

Asia Pacific	+65 6355-2828
	+65 6445-3033 Fax
Europe	+44 (0) 1698 481481
	+44 (0) 1698 481676 Fax
Latin America	+1-305-805-8188
	+1-305-883-8257 Fax
USA/Canada	+1-800-537-6945
	+1-815-235-6847
	+1-815-235-6545 Fax

Данный компонент на территории Российской Федерации

Вы можете приобрести в компании MosChip.

Для оперативного оформления запроса Вам необходимо перейти по данной ссылке:

<http://moschip.ru/get-element>

Вы можете разместить у нас заказ для любого Вашего проекта, будь то серийное производство или разработка единичного прибора.

В нашем ассортименте представлены ведущие мировые производители активных и пассивных электронных компонентов.

Нашей специализацией является поставка электронной компонентной базы двойного назначения, продукции таких производителей как XILINX, Intel (ex.ALTERA), Vicor, Microchip, Texas Instruments, Analog Devices, Mini-Circuits, Amphenol, Glenair.

Сотрудничество с глобальными дистрибьюторами электронных компонентов, предоставляет возможность заказывать и получать с международных складов практически любой перечень компонентов в оптимальные для Вас сроки.

На всех этапах разработки и производства наши партнеры могут получить квалифицированную поддержку опытных инженеров.

Система менеджмента качества компании отвечает требованиям в соответствии с ГОСТ Р ИСО 9001, ГОСТ РВ 0015-002 и ЭС РД 009

Офис по работе с юридическими лицами:

105318, г.Москва, ул.Щербаковская д.3, офис 1107, 1118, ДЦ «Щербаковский»

Телефон: +7 495 668-12-70 (многоканальный)

Факс: +7 495 668-12-70 (доб.304)

E-mail: info@moschip.ru

Skype отдела продаж:

moschip.ru

moschip.ru_4

moschip.ru_6

moschip.ru_9