



Industrial USB Plugs and Receptacles

- 84727** Plug, Type-A
- 84728** Plug, Type-B
- 84729** Receptacle, Type-A
- 84730** Receptacle, Type-B
- 84732** Double-Ended Cordset



Top, Left to right: Double-Ended Cordset, USB Type-B Plug to Type-A Plug (84732)
Bottom: USB Type-B Panel Mount PCB Receptacle (84730)

Industrial USB connectors bring one of the most popular and convenient I/O connectors into harsh commercial and industrial environments

Molex's sealed, industrial Universal Serial Bus (USB) connectors are ideal for industrial and harsh commercial applications, where a secure and robust connection is required. The rugged, plug and receptacle designs feature bayonet-style latches, encapsulated PCB receptacles and overmolded cable assemblies to help keep out dust, debris and water.

Many industrial devices and networks use a direct interface to a PC for programming, monitoring, data collection and diagnostics of the industrial bus. USB connectors are ideal for both short-term diagnostics that require simple and fast setup, and permanent

installations for data acquisition systems. Once software has been installed, USB plugs and receptacles can be quickly connected and disconnected from various devices without having to turn off computers or equipment.

High performance results and ease-of-use make industrial USB from Molex a valuable solution for a variety of harsh environment applications.

For more information on Industrial USB Plugs and Receptacles, please visit: www.molex.com/product/industrialusb.html.

Features and Benefits

- IP 67 and NEMA 6P ratings ensure cordsets are water and dust tight for functional integrity
- Overmolded cordsets allow for faster installation at customer site versus field-wireable designs
- Bayonet-style latch receptacle provides quick and easy connection and ensures proper insertion depth with mating
- Cordsets available in varied lengths up to 5.00m (16.40') which allows customers to choose the length convenient for their specific application
- Fully shielded cable provides Electro Magnetic Interference/Radio Frequency Interference (EMI/RFI) protection

SPECIFICATIONS

Reference Information

Packaging: Bag
Mates with: 84727 mates with 84729
84728 mates with 84730
84732 mates with 84729/84730
Minimum Order Qty.: 10
Standard Pack Size: 1

Electrical

Voltage: 30V
Current: 1.0A
Contact Resistance: 30 milliohms max.
Dielectric Withstanding Voltage: 750V AC
Insulation Resistance: 1000 Megohms min.

Mechanical

Lock Nut Destructive Torque:
2.71 Nm (24.0 in. lb) min.
Coupling Ring Destructive Torque:
2.26 Nm (20.0 in. lb) min.
Mating Force: 35N (7.87 lbf) max.
Withdrawal Force: 10N (2.25 lbf) min.
Durability: 1000 mating cycles

Physical

Receptacle Housing: PBT, Black
Overmolding: PVC, Black
Contact: Copper Alloy
Plating: Contact Area - 0.75µm (30µ") Gold (Au)
Screw - Nickel
Gasket Seal: Nitrile, Black
Coupling Ring: PBT, Black
Lock Nut: PBT, Black
Screw: Brass
Dust Cap: PBT, Black
Tether: PP or PE, Black
Operating Temperature: 0 to +70°C
RoHS Compliant: Yes
Flammability: UL 94V-0
Performance: USB 2.0
Industrial Seal Rating: NEMA 6P and IP 67

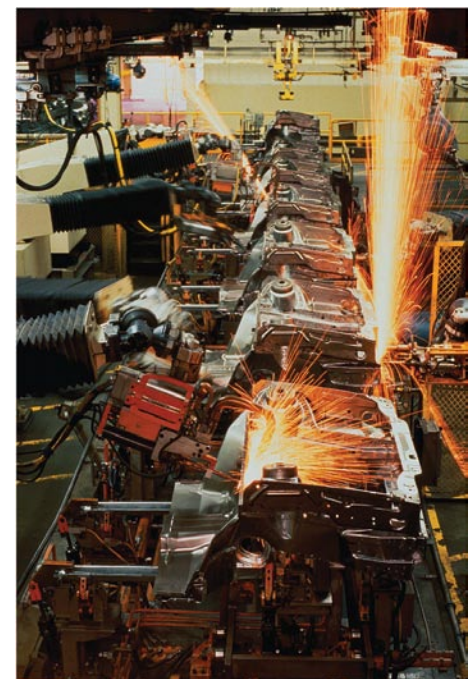

APPLICATIONS



Industrial USB Plugs and Receptacles

- Factory Automation
 - Industrial Computers
 - Industrial Controllers
 - Factory Peripherals
 - Printers
 - Barcode Scanners
- Robotics
- Vision Systems
- Motion and Process Controls
- Test and Measurement Equipment
- Medical Devices
- Factory Networking Installations
- Production Equipment



Test and Measurement Equipment

- 84727** Plug, Type-A
- 84728** Plug, Type-B
- 84729** Receptacle, Type-A
- 84730** Receptacle, Type-B
- 84732** Double-Ended Cordset

ORDERING INFORMATION

USB Plug, Shielded Pigtail

| USB Type-A Order No. | USB Type-B Order No. | Length |
|-------------------------|-------------------------|-----------------|
| 84727-1002 | 84728-1002 | 1.50m (4.921') |
| 84727-1001 | 84728-1001 | 2.00m (6.561') |
| 84727-1003 | 84728-1003 | 3.00m (9.842') |
| 84727-1004 | 84728-1004 | 5.00m (16.404') |
| 84727-1005 | 84728-1005 | 0.15m (.492') |

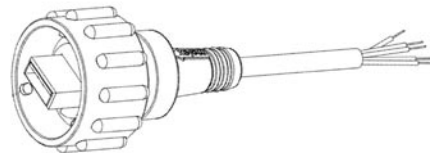

USB Type-A Plug to Pigtail

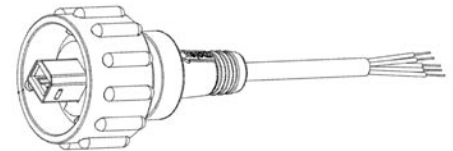

USB Type-B Plug to Pigtail

USB Type-A Panel Mount Receptacle to Standard USB Type-A Plug Cordset

| Order No. | Length |
|------------|-----------------|
| 84729-0003 | 0.152m (.498') |
| 84729-0004 | 0.80m (2.624') |
| 84729-0005 | 1.50m (4.921') |
| 84729-0006 | 2.00m (6.561') |
| 84729-0007 | 3.00m (9.842') |
| 84729-0008 | 5.00m (16.404') |

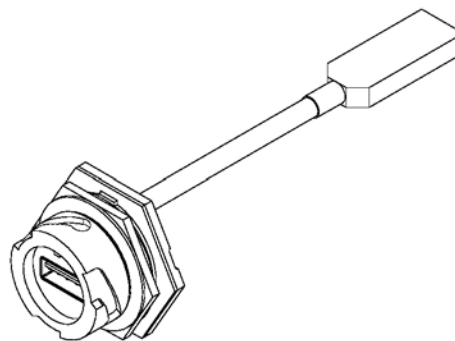

USB Type-A Panel Mount Receptacle to Standard USB Type-A Plug Cordset (Series 84729)



Industrial USB Plugs and Receptacles

- 84727** Plug, Type-A
- 84728** Plug, Type-B
- 84729** Receptacle, Type-A
- 84730** Receptacle, Type-B
- 84732** Double-Ended Cordset

USB Panel Mount PCB Receptacle

| Order No. | USB Type |
|------------|----------|
| 84729-0009 | A |
| 84730-0001 | B |

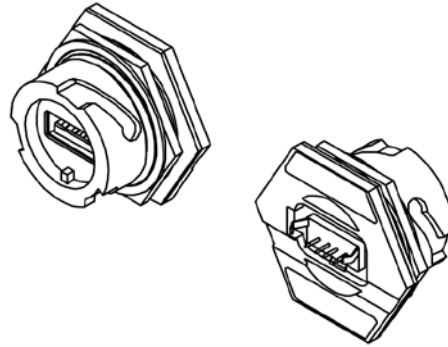

USB Type-A Panel Mount Receptacles with PCB tails (Series 84729)

USB Type-A Panel Mount Receptacle, 5-Circuit Pigtail

| Order No. | Length |
|------------|----------------|
| 84729-0001 | 0.152m (.498') |

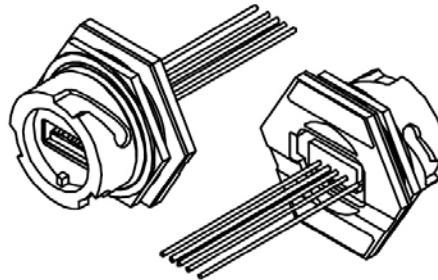

USB Type-A Panel Mount Receptacles to 5-Circuit Pigtail (Series 84729)

USB Type-A Plug to USB Type-B Plug, Double-Ended Cordset

| Order No. | Length |
|------------|-----------------|
| 84732-0001 | 0.80m (2.624') |
| 84732-0002 | 1.50m (4.921') |
| 84732-0003 | 2.00m (6.561') |
| 84732-0004 | 3.00m (9.842') |
| 84732-0005 | 5.00m (16.404') |

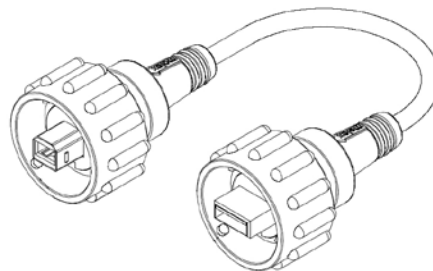

USB Type-B Plug to USB Type-A Plug Double-Ended Cordset (Series 84732)

Assembly Dust Cover

| Order No. |
|------------|
| 84700-0003 |

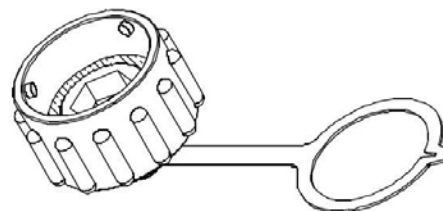

Dust Cover (Series 84700)

Americas Headquarters
Lisle, Illinois 60532 U.S.A.
1-800-78MOLEX
amerinfo@molex.com

Asia Pacific North Headquarters
Yamato, Kanagawa, Japan
81-462-65-2324
feninfo@molex.com

Asia Pacific South Headquarters
Jurong, Singapore
65-6268-6868
fesinfo@molex.com

European Headquarters
Munich, Germany
49-89-413092-0
eurinfo@molex.com

Corporate Headquarters
2222 Wellington Ct.
Lisle, IL 60532 U.S.A.
630-969-4550
Fax: 630-969-1352

Visit our website at www.molex.com/product/industrialusb.html

Данный компонент на территории Российской Федерации

Вы можете приобрести в компании MosChip.

Для оперативного оформления запроса Вам необходимо перейти по данной ссылке:

<http://moschip.ru/get-element>

Вы можете разместить у нас заказ для любого Вашего проекта, будь то серийное производство или разработка единичного прибора.

В нашем ассортименте представлены ведущие мировые производители активных и пассивных электронных компонентов.

Нашей специализацией является поставка электронной компонентной базы двойного назначения, продукции таких производителей как XILINX, Intel (ex.ALTERA), Vicor, Microchip, Texas Instruments, Analog Devices, Mini-Circuits, Amphenol, Glenair.

Сотрудничество с глобальными дистрибьюторами электронных компонентов, предоставляет возможность заказывать и получать с международных складов практически любой перечень компонентов в оптимальные для Вас сроки.

На всех этапах разработки и производства наши партнеры могут получить квалифицированную поддержку опытных инженеров.

Система менеджмента качества компании отвечает требованиям в соответствии с ГОСТ Р ИСО 9001, ГОСТ РВ 0015-002 и ЭС РД 009

Офис по работе с юридическими лицами:

105318, г.Москва, ул.Щербаковская д.3, офис 1107, 1118, ДЦ «Щербаковский»

Телефон: +7 495 668-12-70 (многоканальный)

Факс: +7 495 668-12-70 (доб.304)

E-mail: info@moschip.ru

Skype отдела продаж:

moschip.ru

moschip.ru_4

moschip.ru_6

moschip.ru_9