



SANYO Semiconductors

DATA SHEET

An ON Semiconductor Company

LB1868M — Monolithic Digital IC 2-phase Brushless Fan Motor Driver

Overview

The LB1868M is a 2-phase unipolar brushless motor driver. With only a few peripheral parts, lockup protection and automatic recovery can be implemented. The IC can be configured for 12V or 24V operation and a wide range of variations, from Low speed to H-High speed and from 60cm to 120cm square using the same PCB. This makes it easy to design highly reliable fan motor installations.

Features

- Output protection Zener diode with variable withstand voltage
Z1, Z2 pins open: $V_{OLM} = 57V$ (24V specification)
Z1, Z2 pins shorted: $V_{OLM} = 32V$ (12V specification)
External Zener diode connected across Z1 – V_{CC} pins: support for fans with large drive current
- External resistor allows configuration for 12V or 24V
- Direct Hall element connection possible (built-in Hall amplifier with hysteresis supports core without auxiliary electrode)
- Built-in output transistor with 1.0A output current (strengthened negative-current support for core without auxiliary electrode)
- Built-in rotation detection function: Low during rotation and High during stop
- Built-in lockup protection with automatic recovery
- ST pin for motor stop/drive (for standby mode of copiers etc.)
- BC pin for kickback noise reduction (with 2 external capacitors)
- FG output pin for rotation detection
- Built-in thermal shutdown

Specifications

Absolute Maximum Ratings at $T_a = 25^\circ C$

Parameter	Symbol	Conditions	Ratings	Unit
Maximum input current	$I_{CC\ max}$	$t \leq 20ms$	200	mA
Maximum applied output voltage	$V_{OUT\ max}$		Internal	V
Maximum output current	$I_{OUT\ max}$		1.0	A
Current flowing into RD, FG	$I_{RD\ max}$		10	mA
RD, FG applied voltage	$V_{RD\ max}$		30	V
ST applied voltage	$V_{ST\ max}$		7.5	V
Allowable power dissipation	$P_d\ max$	Mounted on a specified board *	800	mW
Operating temperature	T_{opr}		-30 to +80	$^\circ C$
Storage temperature	T_{stg}		-55 to +150	$^\circ C$

* Specified board: 20mm × 15mm × 1.5mm, glass epoxy board.

■ Any and all SANYO Semiconductor Co.,Ltd. products described or contained herein are, with regard to "standard application", intended for the use as general electronics equipment (home appliances, AV equipment, communication device, office equipment, industrial equipment etc.). The products mentioned herein shall not be intended for use for any "special application" (medical equipment whose purpose is to sustain life, aerospace instrument, nuclear control device, burning appliances, transportation machine, traffic signal system, safety equipment etc.) that shall require extremely high level of reliability and can directly threaten human lives in case of failure or malfunction of the product or may cause harm to human bodies, nor shall they grant any guarantee thereof. If you should intend to use our products for applications outside the standard applications of our customer who is considering such use and/or outside the scope of our intended standard applications, please consult with us prior to the intended use. If there is no consultation or inquiry before the intended use, our customer shall be solely responsible for the use.

■ Specifications of any and all SANYO Semiconductor Co.,Ltd. products described or contained herein stipulate the performance, characteristics, and functions of the described products in the independent state, and are not guarantees of the performance, characteristics, and functions of the described products as mounted in the customer's products or equipment. To verify symptoms and states that cannot be evaluated in an independent device, the customer should always evaluate and test devices mounted in the customer's products or equipment.

SANYO Semiconductor Co., Ltd.

<http://www.sanyosemi.com/en/network/>

LB1868M

Allowable Operating Ranges at $T_a = 25^\circ\text{C}$

Parameter	Symbol	Conditions	Ratings	Unit
Input current range	I_{CC}		6.0 to 50	mA
Common mode input voltage range	V_{ICM}		0.2 to $V_{IN}-1.5$	V
ST High voltage	V_{STH}		4.5 to 7.0	V
ST Low voltage	V_{STL}		0 to 0.5	V

Electrical Characteristics at $T_a = 25^\circ\text{C}$, $I_{CC} = 10\text{mA}$

Parameter	Symbol	Conditions	Ratings			Unit
			min	typ	max	
Output limiter withstand voltage	V_{OLM1}	Z1, Z2 open	54	57	60	V
	V_{OLM2}	Z1, Z2 short	31	33	35	V
Output saturation voltage	V_{Osat1}	$I_O = 0.5\text{A}$		0.95	1.2	V
	V_{Osat2}	$I_O = 1.0\text{A}$		1.15	1.5	V
V_{IN} voltage	V_{IN}	$I_{CC} = 7.0\text{mA}$	6.4	6.7	7.0	V
Hall input sensitivity (at zero peak)	V_{HN}	Including offset and hysteresis			20	mV
RD, FG output saturation voltage	V_{RDSat}	$I_{RD} = 5\text{mA}$		0.1	0.3	V
CT drain current	IC1	C = GND	2.7	3.8	4.9	μA
CT discharge current	IC2	C = V_{IN}	0.19	0.30	0.41	μA
Comp input threshold voltage	V_{TH1}		0.77	$0.8V_{IN}$	0.83	V
	V_{TH2}		0.42	$0.45V_{IN}$	0.48	V
ST input current	I_{ST}	$V_{ST} = 5\text{V}$		80	120	μA
Thermal protection operating temperature	TSD	Design target value *		180		$^\circ\text{C}$
Thermal protection circuit hysteresis	ΔTSD	Design target value *		40		$^\circ\text{C}$

* Design target value, Do not measurement.

Package Dimensions

unit : mm (typ)

3111A

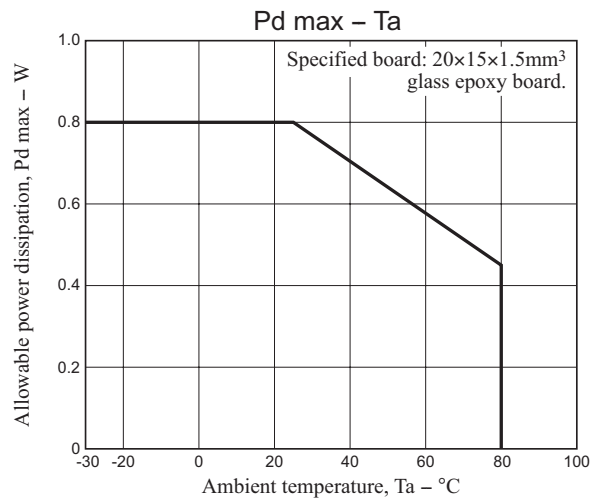
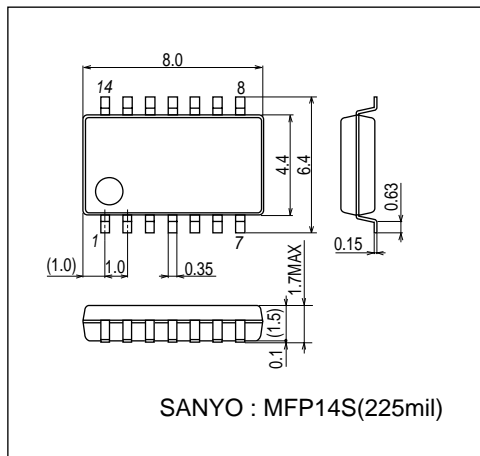

LB1868M

Pin Assignment

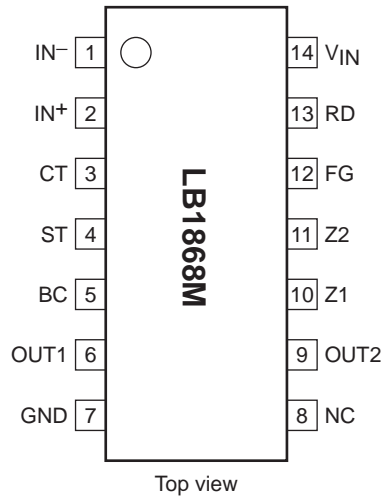

Pin Function

Pin No.	Pin name	Function
1	IN ⁻	Hall input + pin. Hysteresis amplifier
2	IN ⁺	Hall input – pin. Hysteresis amplifier
3	CT	Lockup protection time setting capacitor pin (0.47 to 4.7 μ F).
4	ST	Start/stop pin.
5	BC	Output transistor common base pin.
6	OUT1	Output 1 pin.
9	OUT2	Output 2 pin.
7	GND	GND pin.
10	Z1	External Zener diode pin (external Zener diode to be connected between power supply and Z1).
11	Z2	Kickback absorption voltage alteration pin (shorted to Z1: 12V operation).
12	FG	Rotation frequency detector pin.
13	RD	Lockup detection pin (latch type).
14	V _{IN}	Regulated power supply input pin (limiting resistor to be inserted between power supply and V _{IN}).

Truth Table

ST	IN ⁺	IN ⁻	CT	OUT1	OUT2	RD	FG
H	H	L	L	H	H	L	L
	L	H	L	H	H	L	H
L or OPEN	H	L	L	H	L	L	L
	L	H	L	L	H	L	H
	H	L	H	H	H	H	L
	L	H	H	H	H	H	H

* RD is a latch type output

LB1868M

Block Diagram

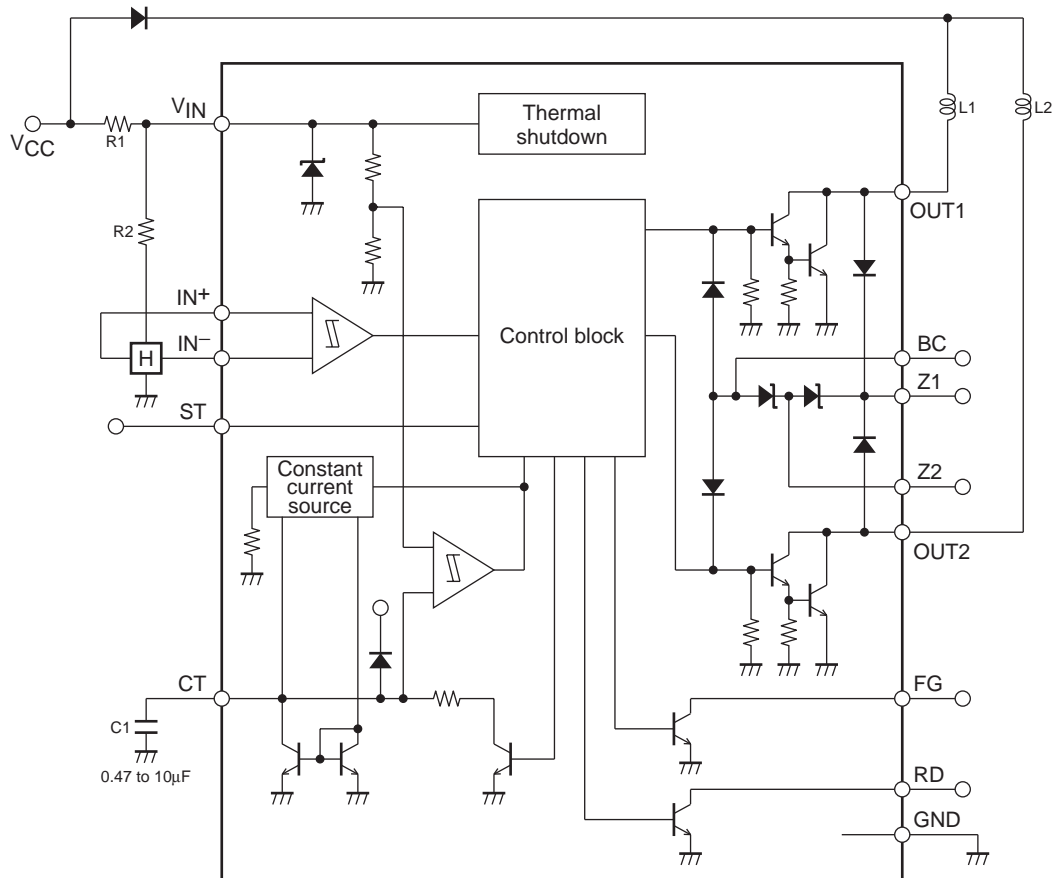

Application Circuit Example

(1) 12V supply voltage

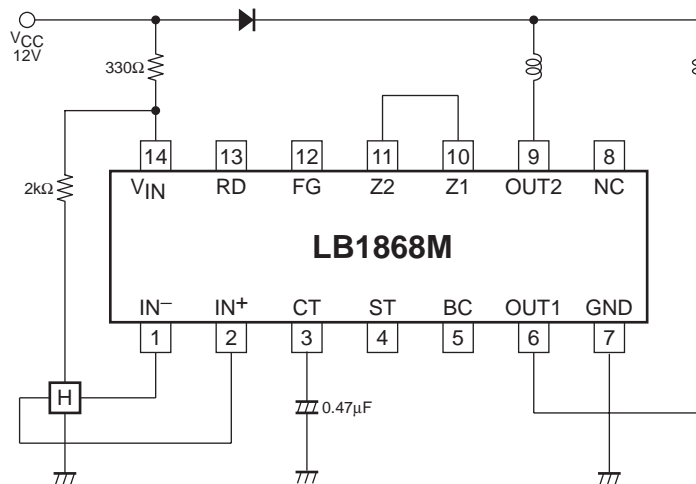

LB1868M

(2) 24V supply voltage

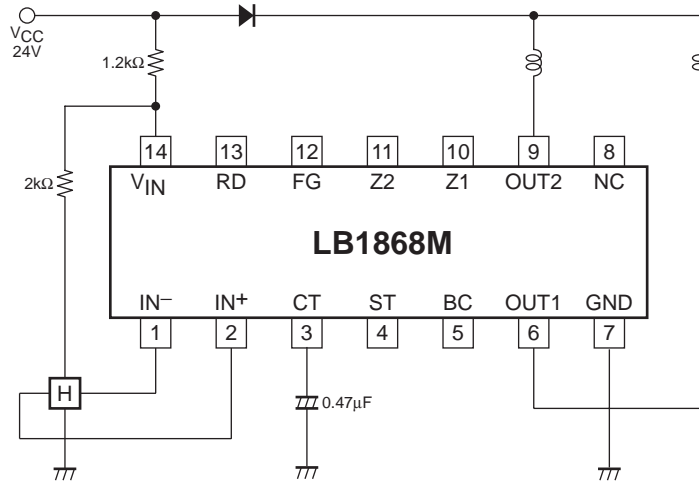

(3) High-Power Fan (120mm-HH-Speed)

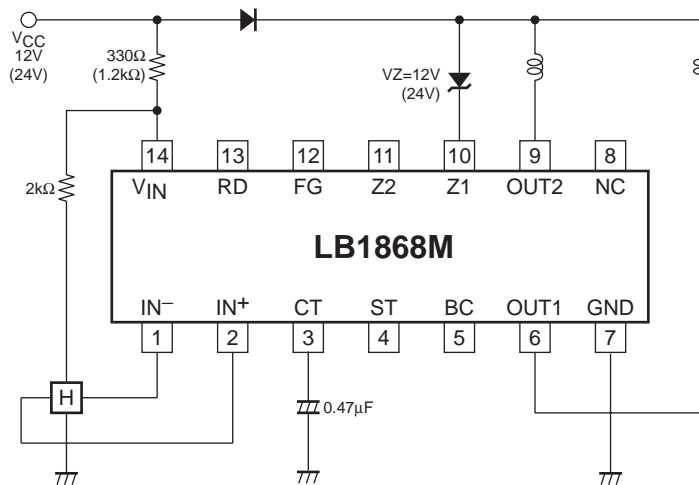

- SANYO Semiconductor Co.,Ltd. assumes no responsibility for equipment failures that result from using products at values that exceed, even momentarily, rated values (such as maximum ratings, operating condition ranges, or other parameters) listed in products specifications of any and all SANYO Semiconductor Co.,Ltd. products described or contained herein.
- SANYO Semiconductor Co.,Ltd. strives to supply high-quality high-reliability products, however, any and all semiconductor products fail or malfunction with some probability. It is possible that these probabilistic failures or malfunction could give rise to accidents or events that could endanger human lives, trouble that could give rise to smoke or fire, or accidents that could cause damage to other property. When designing equipment, adopt safety measures so that these kinds of accidents or events cannot occur. Such measures include but are not limited to protective circuits and error prevention circuits for safe design, redundant design, and structural design.
- In the event that any or all SANYO Semiconductor Co.,Ltd. products described or contained herein are controlled under any of applicable local export control laws and regulations, such products may require the export license from the authorities concerned in accordance with the above law.
- No part of this publication may be reproduced or transmitted in any form or by any means, electronic or mechanical, including photocopying and recording, or any information storage or retrieval system, or otherwise, without the prior written consent of SANYO Semiconductor Co.,Ltd.
- Any and all information described or contained herein are subject to change without notice due to product/technology improvement, etc. When designing equipment, refer to the "Delivery Specification" for the SANYO Semiconductor Co.,Ltd. product that you intend to use.
- Information (including circuit diagrams and circuit parameters) herein is for example only; it is not guaranteed for volume production.
- Upon using the technical information or products described herein, neither warranty nor license shall be granted with regard to intellectual property rights or any other rights of SANYO Semiconductor Co.,Ltd. or any third party. SANYO Semiconductor Co.,Ltd. shall not be liable for any claim or suits with regard to a third party's intellectual property rights which has resulted from the use of the technical information and products mentioned above.

This catalog provides information as of March, 2009. Specifications and information herein are subject to change without notice.

Данный компонент на территории Российской Федерации

Вы можете приобрести в компании MosChip.

Для оперативного оформления запроса Вам необходимо перейти по данной ссылке:

<http://moschip.ru/get-element>

Вы можете разместить у нас заказ для любого Вашего проекта, будь то серийное производство или разработка единичного прибора.

В нашем ассортименте представлены ведущие мировые производители активных и пассивных электронных компонентов.

Нашей специализацией является поставка электронной компонентной базы двойного назначения, продукции таких производителей как XILINX, Intel (ex.ALTERA), Vicor, Microchip, Texas Instruments, Analog Devices, Mini-Circuits, Amphenol, Glenair.

Сотрудничество с глобальными дистрибьюторами электронных компонентов, предоставляет возможность заказывать и получать с международных складов практически любой перечень компонентов в оптимальные для Вас сроки.

На всех этапах разработки и производства наши партнеры могут получить квалифицированную поддержку опытных инженеров.

Система менеджмента качества компании отвечает требованиям в соответствии с ГОСТ Р ИСО 9001, ГОСТ РВ 0015-002 и ЭС РД 009

Офис по работе с юридическими лицами:

105318, г.Москва, ул.Щербаковская д.3, офис 1107, 1118, ДЦ «Щербаковский»

Телефон: +7 495 668-12-70 (многоканальный)

Факс: +7 495 668-12-70 (доб.304)

E-mail: info@moschip.ru

Skype отдела продаж:

moschip.ru

moschip.ru_4

moschip.ru_6

moschip.ru_9