

IS31BL3232

FLASH LED DRIVER

May 2013

GENERAL DESCRIPTION

The IS31BL3232 is a current-regulated charge pump and ideal for powering high brightness LEDs for camera flash and torch applications. The charge pump can be set to regulate two current levels for Flash and Torch modes. The IS31BL3232 automatically switches between linear and boost modes ensuring that LED current does not depend on the LED forward voltage. In the Flash Mode the output will shut down automatically after 1s to save energy.

IS31BL3232 provides low cost, space saving solution for driving LED. It also integrates thermal and short circuit protection function.

IS31BL3232 is available in DFN-10 (3mm × 3mm). It operates from 2.7V to 5.5V over the temperature range of -40°C to +85°C.

FEATURES

- Operates from 2.7V to 5.5V
- Up to 90% efficiency in Torch Mode
- Output current up to 1.2A(1s) in Flash Mode
- Adjustable output current in Flash Mode
- Time out function with 1s for Flash Mode
- Minimum external components, no external inductor required
- Automatic boost mode
- Less than 1µA shutdown current
- Low ripple and EMI
- Over voltage protection on output
- ESD HBM 8kV
- Short and over temperature protections
- Available in DFN-10 (3mm × 3mm) package

APPLICATIONS

- White LED backlighting
- Cellular phones
- Generic lighting/flash/strobe applications

TYPICAL APPLICATION CIRCUIT

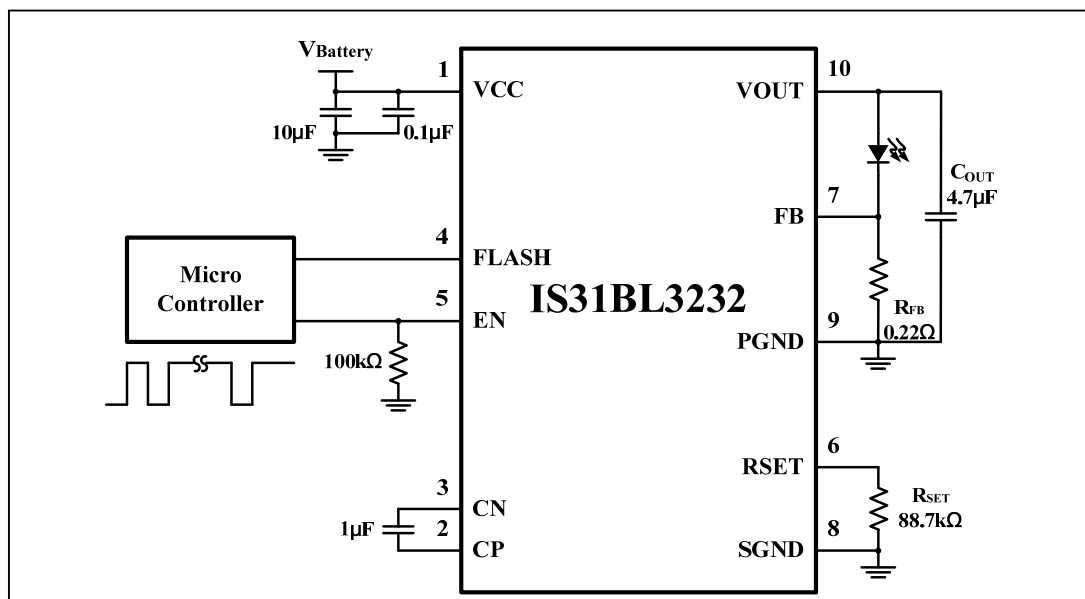

Figure 1 Typical Application Circuit (Torch Mode Lv1-227mA, Flash Mode 718mA)

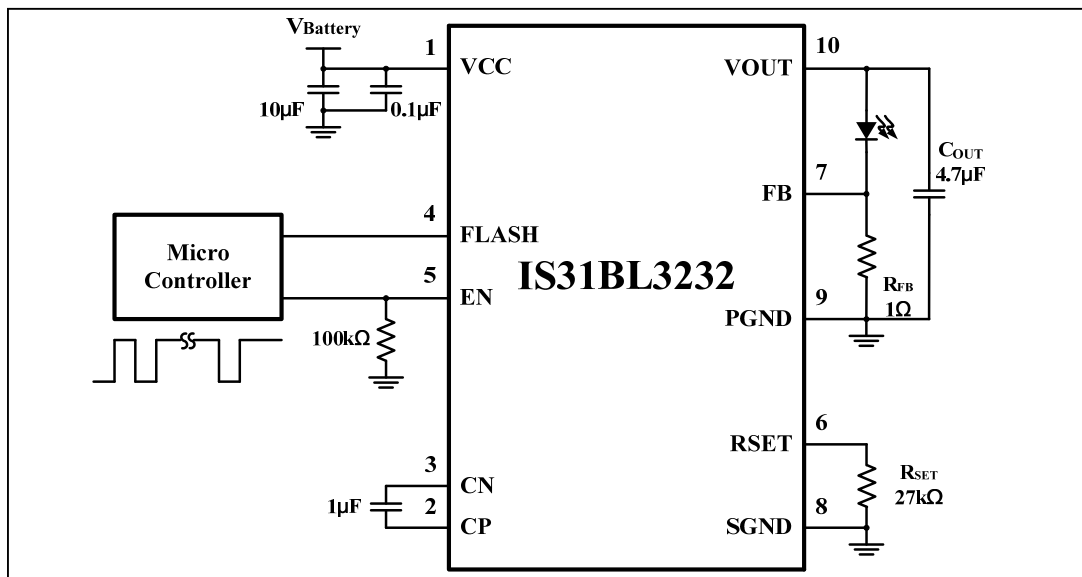
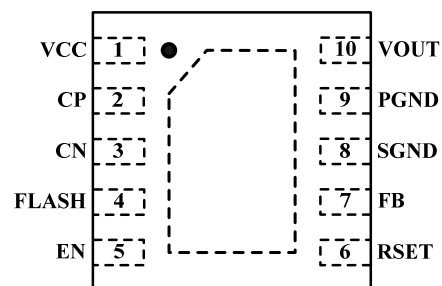

Figure 2 Typical Application Circuit (Torch Mode Lv1-50mA, Flash Mode 518mA)

IS31BL3232

PIN CONFIGURATION

Package	Pin Configuration (Top View)
DFN-10	

PIN DESCRIPTION

No.	Pin	Description
1	VCC	Power supply.
2	CP	Positive input for external flying cap.
3	CN	Negative input for external flying cap.
4	FLASH	Input pin to toggle operation between Flash Mode and Torch Mode.
5	EN	Shutdown control input and Torch reference select pin.
6	RSET	Set the FB voltage in Flash Mode. $V_{FB} = (1.25V / R_{SET}) \times 11.2k\Omega$
7	FB	Feedback input for the current control loop. $I_{LED} = V_{FB} / R_{FB}$
8	SGND	Internal ground pin.
9	PGND	Power ground pin.
10	VOUT	Charge pump output voltage.
	Thermal Pad	Connect to GND.



IS31BL3232

ORDERING INFORMATION

Industrial Range: -40°C to +85°C

Order Part No.	Package	QTY/Reel
IS31BL3232-DLS2-TR	DFN-10, Lead-free	2500

Copyright © 2013 Integrated Silicon Solution, Inc. All rights reserved. ISSI reserves the right to make changes to this specification and its products at any time without notice. ISSI assumes no liability arising out of the application or use of any information, products or services described herein. Customers are advised to obtain the latest version of this device specification before relying on any published information and before placing orders for products. Integrated Silicon Solution, Inc. does not recommend the use of any of its products in life support applications where the failure or malfunction of the product can reasonably be expected to cause failure of the life support system or to significantly affect its safety or effectiveness. Products are not authorized for use in such applications unless Integrated Silicon Solution, Inc. receives written assurance to its satisfaction, that:

- a.) the risk of injury or damage has been minimized;
- b.) the user assume all such risks; and
- c.) potential liability of Integrated Silicon Solution, Inc is adequately protected under the circumstances



IS31BL3232

ABSOLUTE MAXIMUM RATINGS

Supply voltage, V_{CC}	-0.3V ~ +6.0V
Voltage at EN pin	0V ~ 7V
Output current pulse (Flash Mode)	1.5A
Output current pulse (Torch Mode)	0.4A
Maximum junction temperature, T_{JMAX}	150°C
Storage temperature range, T_{STG}	-65°C ~ +150°C
Operating temperature range, T_A	-40°C ~ +85°C

Note:

Stresses beyond those listed under "Absolute Maximum Ratings" may cause permanent damage to the device. These are stress ratings only and functional operation of the device at these or any other condition beyond those indicated in the operational sections of the specifications is not implied. Exposure to absolute maximum rating conditions for extended periods may affect device reliability.

DC CHARACTERISTICS

$T_A = +25^\circ\text{C}$, $V_{CC} = 2.7\text{V} \sim 5.5\text{V}$, unless otherwise stated. Typical value are $T_A = +25^\circ\text{C}$, $V_{CC} = 4.2\text{V}$.

Symbol	Parameter	Condition	Min.	Typ.	Max.	Unit
V_{CC}	Supply voltage		2.7		5.5	V
I_{CC}	Quiescent current	$V_{CC} = 4.2\text{V}$, $V_{FLASH} = 0\text{V}$		0.6	1.3	mA
I_{SD}	Shutdown current	$V_{CC} = 5.5\text{V}$, $V_{EN} = 0\text{V}$		1.5	2.5	μA
t_{ON}	Charge pump soft start time	(Note 1)		550		μs
V_{FB}	FB reference voltage	$V_{FLASH} = V_{CC}$, $R_{SET} = 88.7\text{k}\Omega$		150		mV
		$V_{FLASH} = 0\text{V}$		50		
T_{OVP}	Over temperature protection			160		$^\circ\text{C}$
V_{IH}	Input logic high		1.4			V
V_{IL}	Input logic low				0.4	V
t_{LO}	EN low time	(Note 1)	0.3		75	μs
t_{HI}	EN high time	(Note 1)	0.1		75	μs
t_{OFF}	EN shutdown timeout	(Note 1)		500		μs
t_{LAT}	EN latch timeout	(Note 1)		500		μs

Note 1: Guaranteed by design.

IS31BL3232

TYPICAL PERFORMANCE CHARACTERISTICS

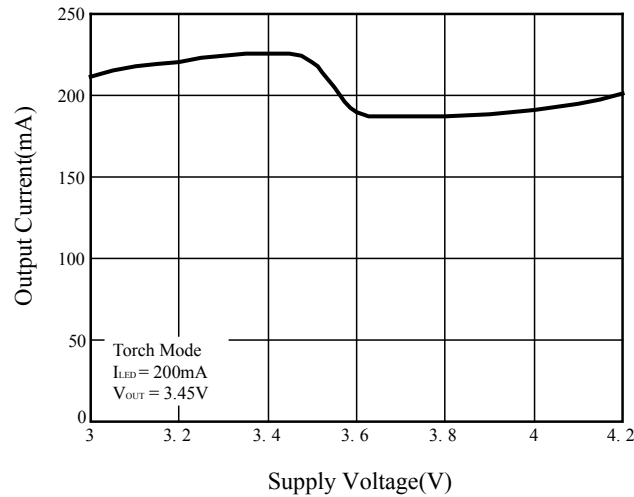

Figure 3 Supply Voltage vs. Output Current (Torch Mode)

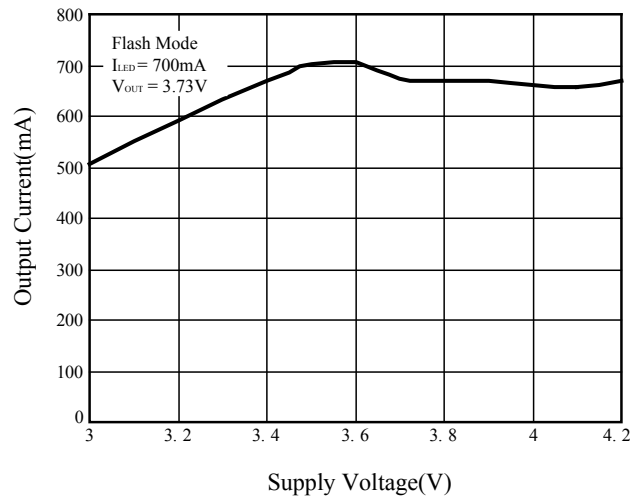

Figure 4 Supply Voltage vs. Output Current (Flash Mode)

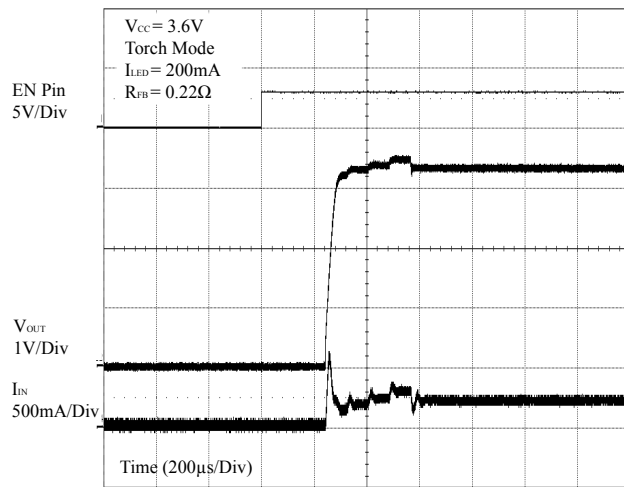

Figure 5 EN On (Torch Mode)

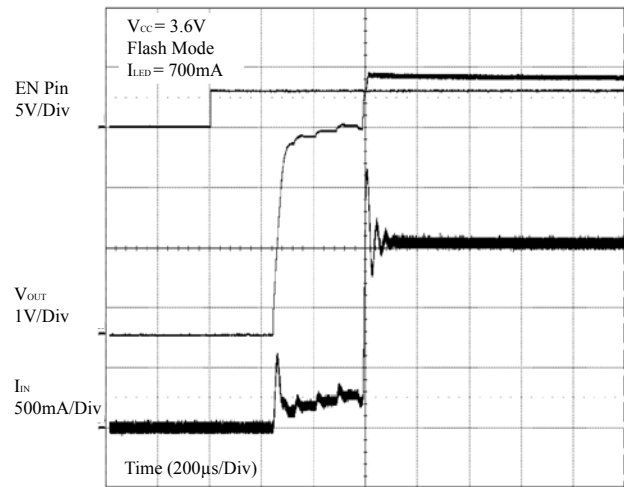

Figure 6 EN On (Flash Mode)

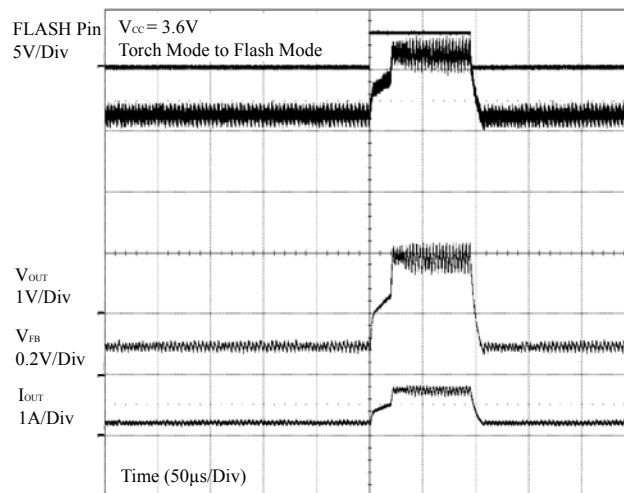

Figure 7 Torch Mode to Flash Mode

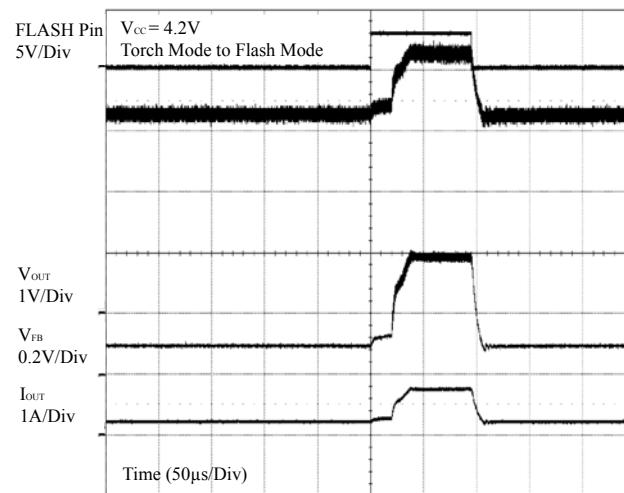

Figure 8 Torch Mode to Flash Mode

IS31BL3232

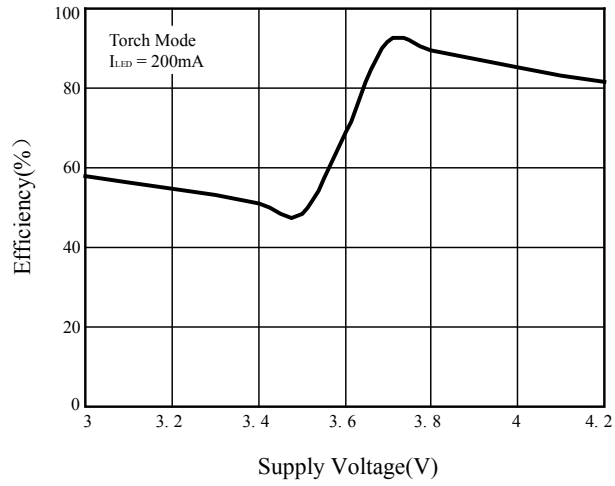

Figure 9 Supply Voltage vs. Efficiency (Torch Mode)

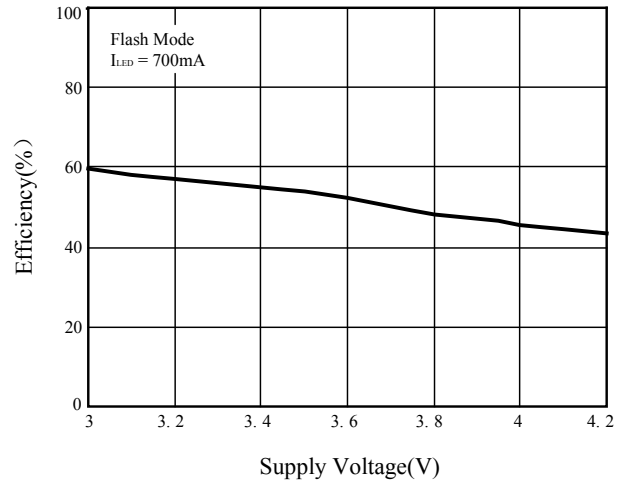
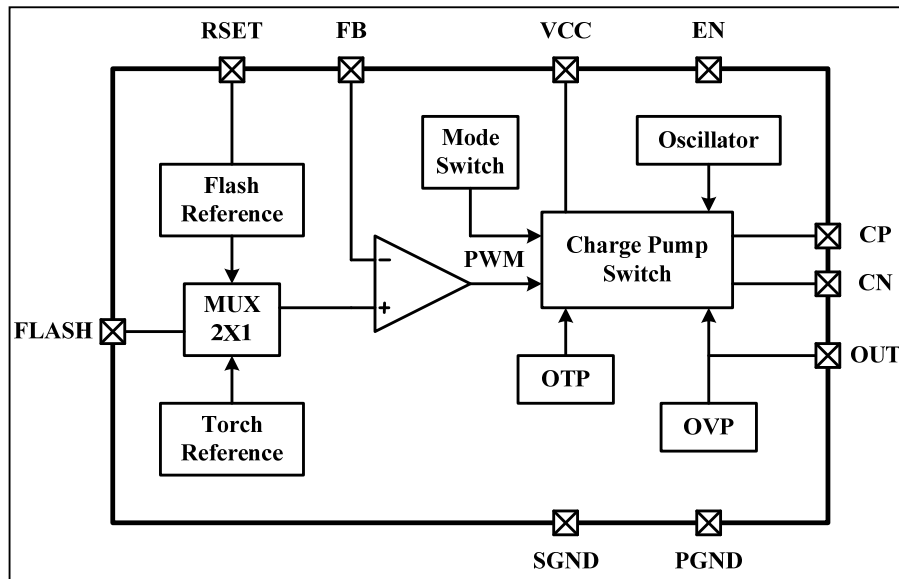

Figure 10 Supply Voltage vs. Efficiency (Flash Mode)

IS31BL3232

FUNCTIONAL BLOCK DIAGRAM



IS31BL3232

APPLICATION INFORMATION

GENERAL DESCRIPTION

The IS31BL3232 is a current-regulated charge pump and ideal for powering high brightness LEDs for camera flash and torch applications.

CHARGE PUMP

The charge pump converter boosts input supply voltage (V_{CC}) up to a higher output voltage (V_{OUT}) to drive LED.

The charge pump converter only requires three external components: supply decoupling capacitor, output bypass capacitor and flying capacitor.

Choose low ESR capacitors to ensure the best operating performance and place the capacitors as close as possible to the IS31BL3232.

The charge pump will start up automatically to offer a higher output voltage when V_{FB} is lower than the setting value.

CURRENT SETTING

The LED current is set by the external resistor, R_{FB} , following the Equation (1) below.

$$I_{LED} = V_{FB} / R_{FB} \quad (1)$$

V_{FB} is calculated by the Equation (2) when IS31BL3232 operates in the Flash Mode. V_{FB} is set in the Table 1 when IS31BL3232 operates in the Torch Mode.

OPERATING MODE

FLASH MODE

By pulling the FLASH pin to high, IS31BL3232 operates in the Flash Mode. V_{FB} is set by the R_{SET} .

$$V_{FB} = (1.25V / R_{SET}) \times 11.2k\Omega \quad (2)$$

For example, in Figure 1,

$$R_{FB} = 0.22\Omega, R_{SET} = 88.7k\Omega,$$

$$\text{So, } V_{FB} = (1.25V / 88.7k\Omega) \times 11.2k\Omega \approx 158mV$$

$$I_{LED} = 158mV / 0.22\Omega \approx 718mA$$

The maximum V_{FB} shouldn't be over 550mV or the actual current will be large difference from then calculated current.

TORCH MODE

By pulling the FLASH pin to low, IS31BL3232 operates in the Torch Mode. The V_{FB} is controlled by Pulse Count Control (PCC wire) serial interface. The interface records rising edges of the EN pin and decodes them into 6 different states. The 6 voltage level settings available are indicated in Table 1.

Table 1 V_{FB} Control

Pulse	V_{FB} (Typ.)	I_{LED} (Typ.)	
		$R_{FB} = 0.22\Omega$	$R_{FB} = 1\Omega$
1	50mV	227mA	50mA
2	60mV	273mA	60mA
3	70mV	318mA	70mA
4	85mV	386mA	85mA
5	100mV	455mA	100mA
6	120mV	545mA	120mA

TIMING CONTROL

The EN pin should be configured as the Figure 11. t_{LAT} is the latch time. High level should be at last t_{LAT} to active the pulse signal. t_{OFF} is the shutdown time. EN pin is pulled low at last t_{OFF} the IC will be shutdown.

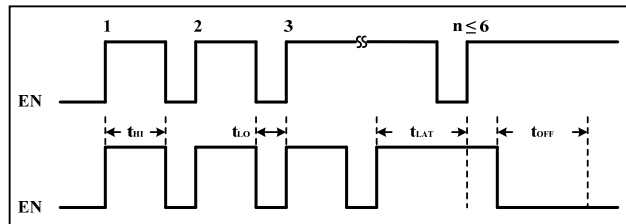

Figure 11 EN pin timing

THERMAL PROTECTION

The IS31BL3232 has a thermal protection circuit that will shut down the chip if the die temperature rises above the thermal limit until the temperature falls down.

IS31BL3232

CLASSIFICATION REFLOW PROFILES

Profile Feature	Pb-Free Assembly
Preheat & Soak Temperature min (T _{smin}) Temperature max (T _{smax}) Time (T _{smin} to T _{smax}) (t _s)	150°C 200°C 60-120 seconds
Average ramp-up rate (T _{smax} to T _p)	3°C/second max.
Liquidous temperature (T _L) Time at liquidous (t _L)	217°C 60-150 seconds
Peak package body temperature (T _p)*	Max 260°C
Time (t _p)** within 5°C of the specified classification temperature (T _c)	Max 30 seconds
Average ramp-down rate (T _p to T _{smax})	6°C/second max.
Time 25°C to peak temperature	8 minutes max.

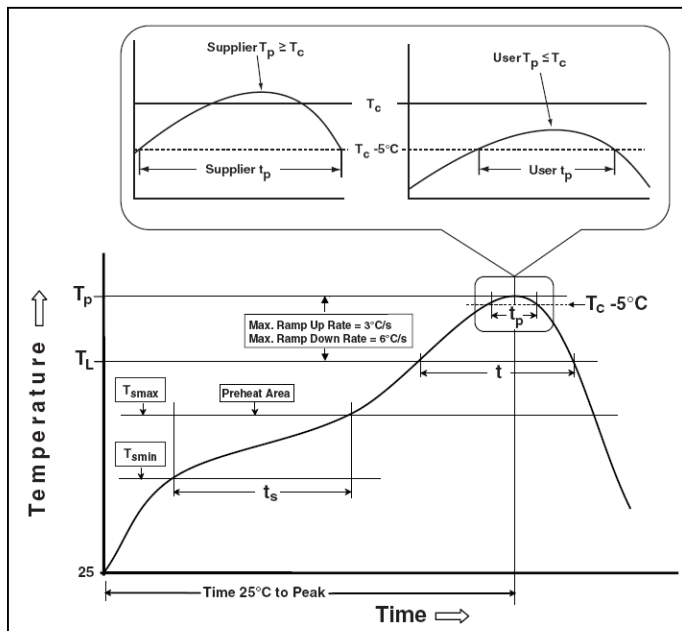
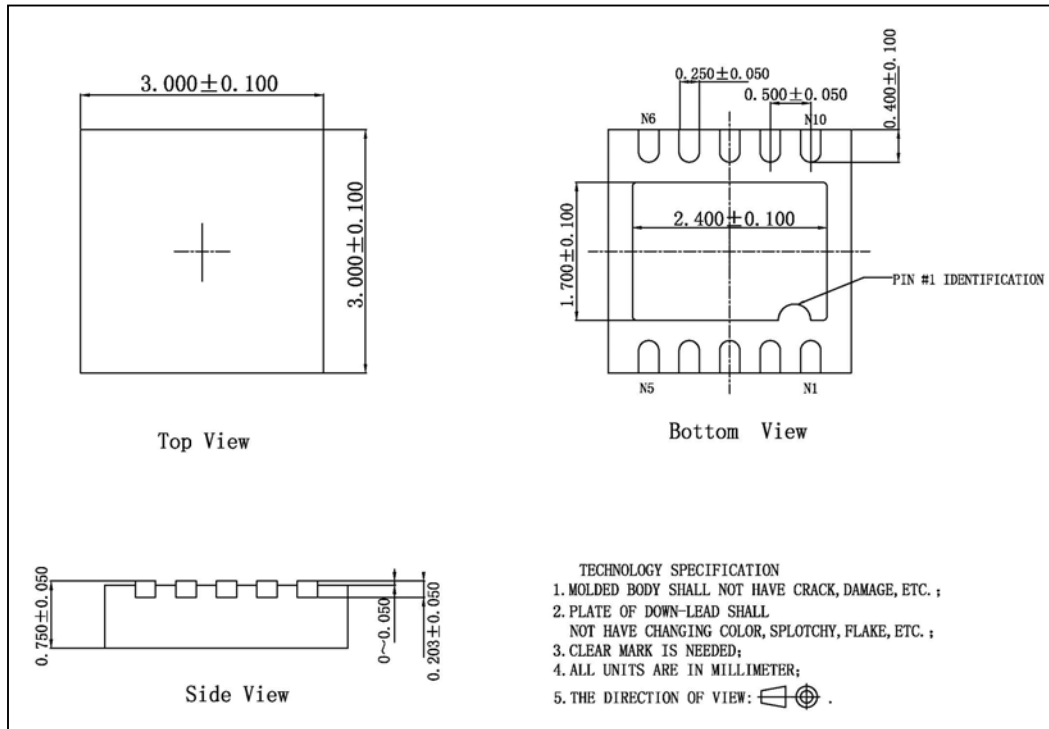

Figure 12 Classification Profile

IS31BL3232

PACKAGE INFORMATION

DFN-10



Note: All dimensions in millimeters unless otherwise stated.

Данный компонент на территории Российской Федерации

Вы можете приобрести в компании MosChip.

Для оперативного оформления запроса Вам необходимо перейти по данной ссылке:

<http://moschip.ru/get-element>

Вы можете разместить у нас заказ для любого Вашего проекта, будь то серийное производство или разработка единичного прибора.

В нашем ассортименте представлены ведущие мировые производители активных и пассивных электронных компонентов.

Нашей специализацией является поставка электронной компонентной базы двойного назначения, продукции таких производителей как XILINX, Intel (ex.ALTERA), Vicor, Microchip, Texas Instruments, Analog Devices, Mini-Circuits, Amphenol, Glenair.

Сотрудничество с глобальными дистрибьюторами электронных компонентов, предоставляет возможность заказывать и получать с международных складов практически любой перечень компонентов в оптимальные для Вас сроки.

На всех этапах разработки и производства наши партнеры могут получить квалифицированную поддержку опытных инженеров.

Система менеджмента качества компании отвечает требованиям в соответствии с ГОСТ Р ИСО 9001, ГОСТ РВ 0015-002 и ЭС РД 009

Офис по работе с юридическими лицами:

105318, г.Москва, ул.Щербаковская д.3, офис 1107, 1118, ДЦ «Щербаковский»

Телефон: +7 495 668-12-70 (многоканальный)

Факс: +7 495 668-12-70 (доб.304)

E-mail: info@moschip.ru

Skype отдела продаж:

moschip.ru

moschip.ru_4

moschip.ru_6

moschip.ru_9