

REVISIONS				
P	LTN	DESCRIPTION	DATE	APVD
	AB	REDRAWN/REVISED PER ECO-17-001755	18MAY2017	RS JO

- 1 CONTACT AREA PLATED WITH 0.76µm MIN GOLD, SOLDER LEADS PLATED WITH 3.81µm TIN LEAD, ALL OVER 1.27µm NICKEL.
- 2 POINT OF MEASUREMENT FOR GOLD THICKNESS.
- 3 CIRCUIT IDENTIFICATION FEATURE OMITTED ON 8, 10, 12, & 14 POSITION HEADER ASSEMBLIES.
- 4 DIMENSION APPLIES AT BASE OF SHROUD.
- 5 NOTE DELETED.
- 6 CONTACT AREA PLATED WITH 0.76µm MIN GOLD, SOLDER LEADS PLATED WITH 3.81µm TIN, ALL OVER 1.27µm NICKEL.
- 7 FINISH: 0.0254µm MIN GOLD ON GOLD PLATED AREA. 3.81-6.35µm MATTE TIN-LEAD ON TIN PLATED AREA. UNDER PLATING TO BE 1.27-2.54µm NICKEL ON ENTIRE CONTACT.
- 8 FINISH: 0.0254µm MIN GOLD ON GOLD PLATED AREA. 3.81-6.35µm MATTE TIN ON TIN PLATED AREA. UNDER PLATING TO BE 1.27-2.54µm NICKEL ON ENTIRE CONTACT.
- 9 NOTE DELETED.
- 10 NOTE DELETED.
- 11 NOTE DELETED.
- 12 MATERIAL : HOUSING : LCP
COLOR : BLACK
CONTACT : COPPER ALLOY.

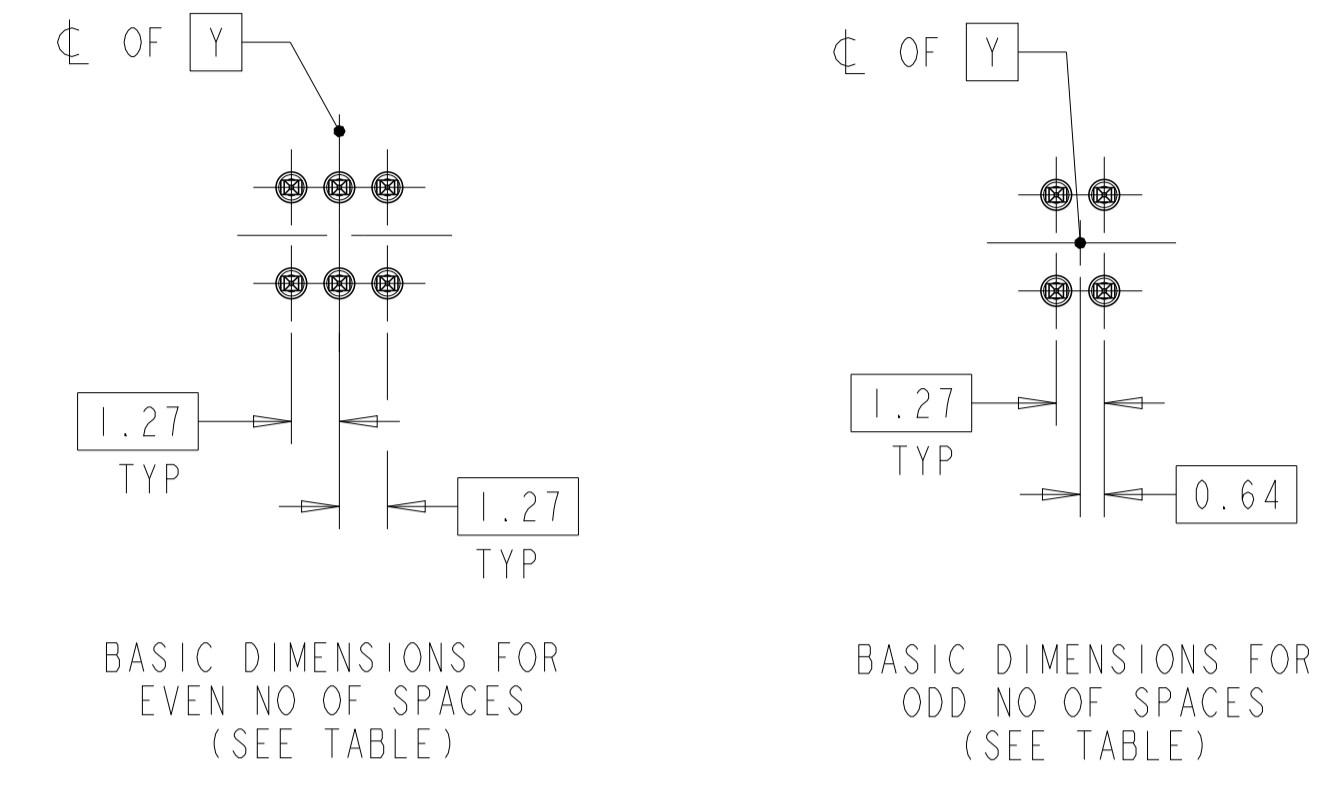
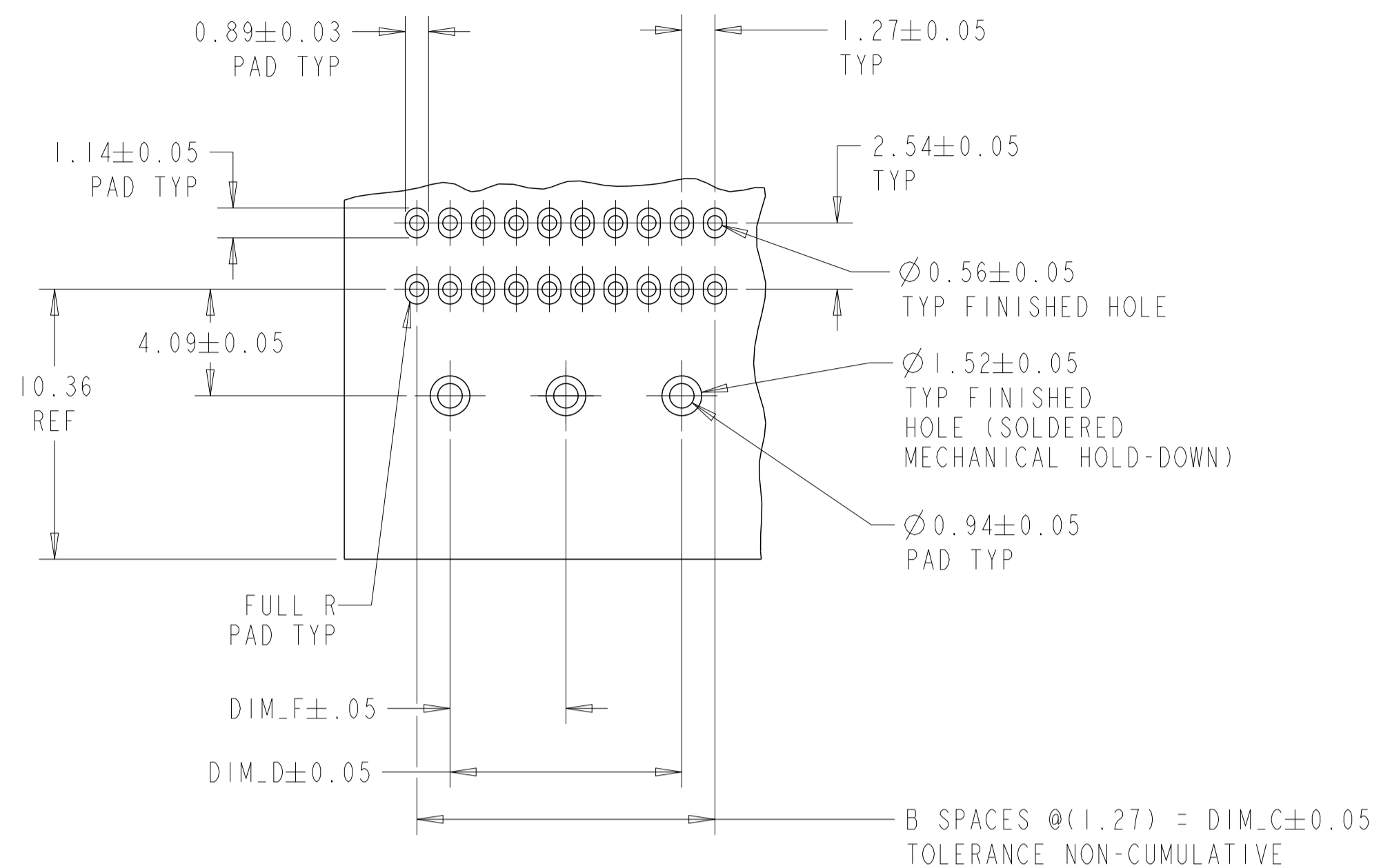

RECOMMENDED HOLE PATTERN

DETAIL R

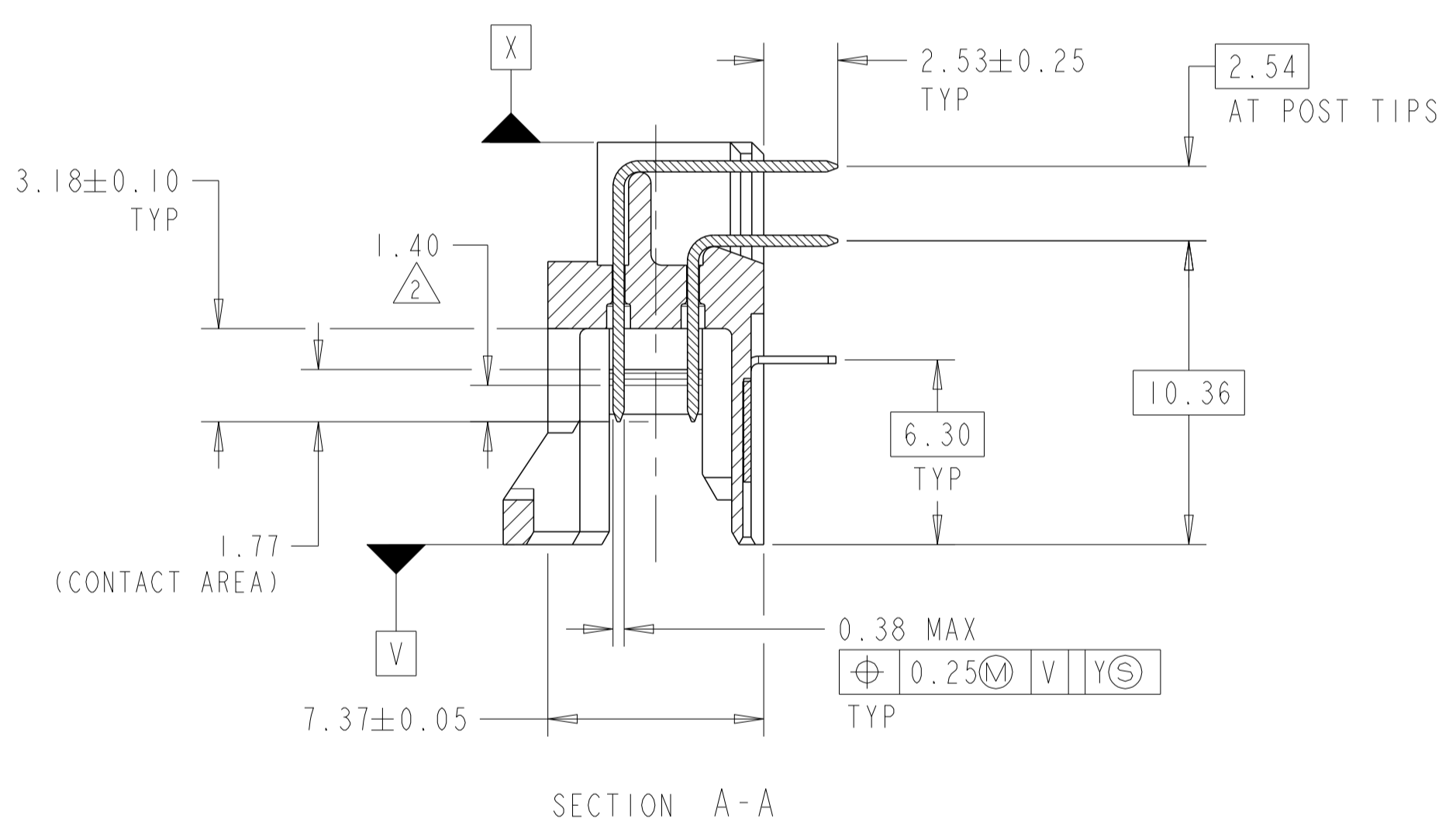
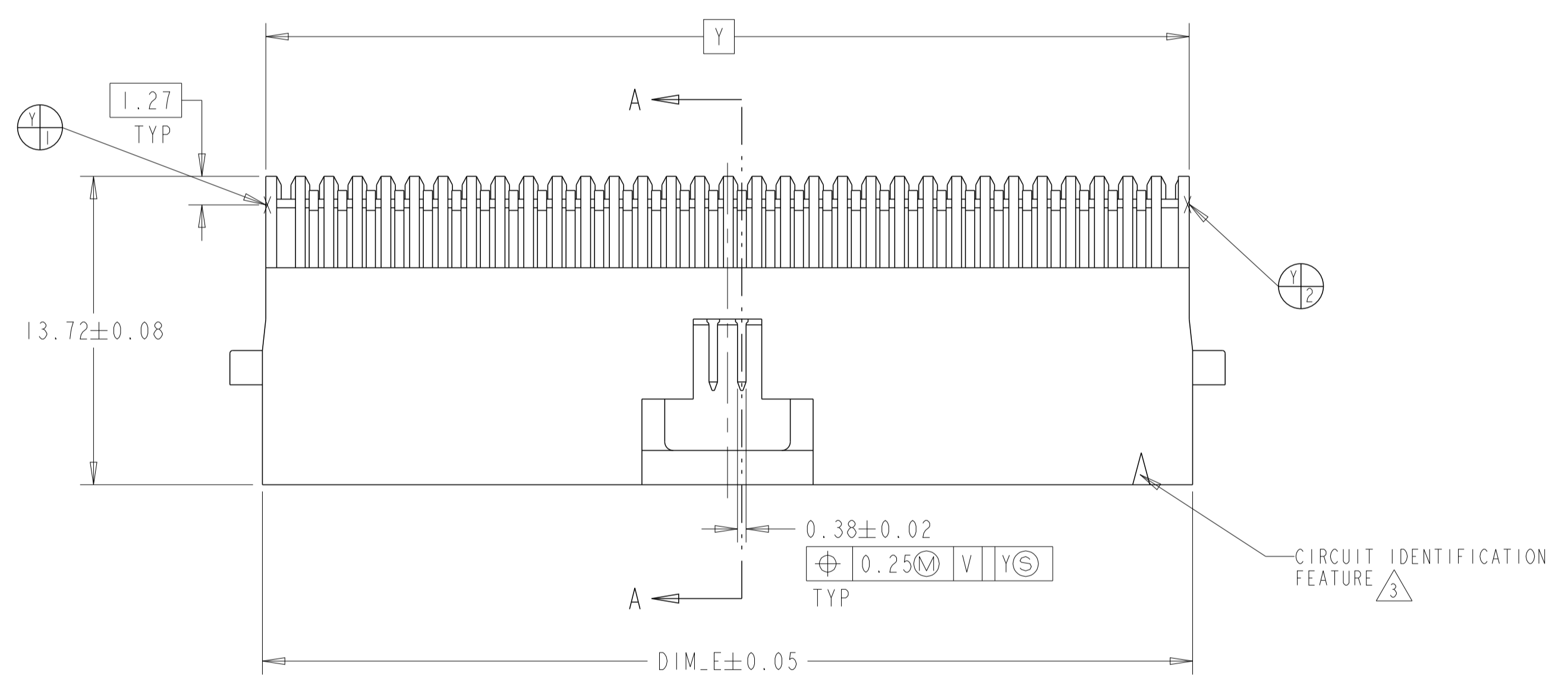

SECTION A-A

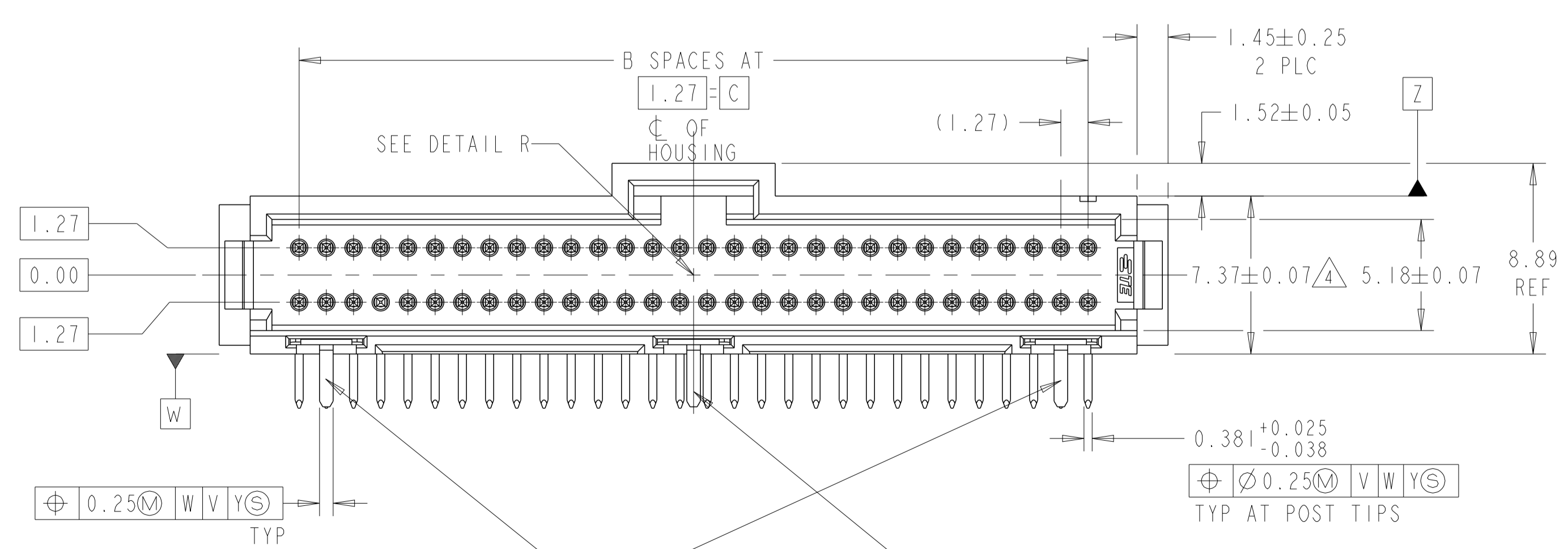

HOLD DOWN FEATURES LOCATED AS SHOWN FOR 16 THRU 100 POSN ASSEMBLIES (SEE TABLE)

HOLD DOWN FEATURES LOCATED AS SHOWN FOR 8 THRU 14&60 THRU 100 POSN ASSEMBLIES (SEE TABLE)

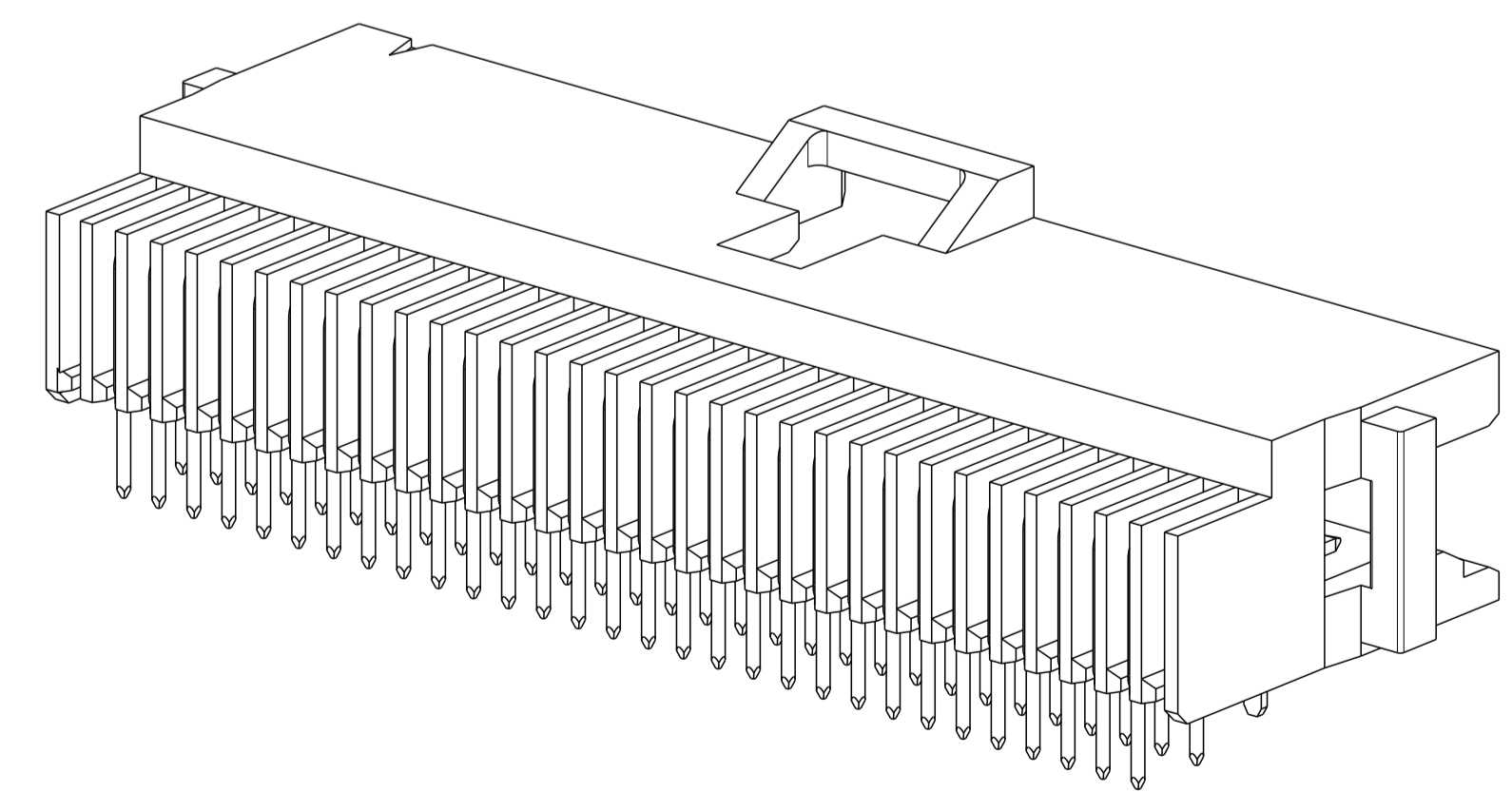

THIS DRAWING IS A CONTROLLED DOCUMENT.		OWN: RAVI.S 18MAY2017	TE Connectivity
DIMENSIONS: mm		CHK: J. OLSON 18MAY2017	
TOLERANCES UNLESS OTHERWISE SPECIFIED:		APVD: J. OLSON 18MAY2017	NAME: HEADER ASSEMBLY, RIGHT ANGLE, DOUBLE ROW, W/SIDE & END LATCHES, AMPMODU System 50
0 PLC	±	PRODUCT SPEC	SIZE: A1
1 PLC	±0.3	APPLICATION SPEC	CAGE CODE: -
2 PLC	±0.13	108-1093	DRAWING NO: C=104069
3 PLC	±	114-25031	SCALE: 5:1
4 PLC	±	WEIGHT: -	SHEET: 1 OF 2
ANGLES	±	CUSTOMER DRAWING	REV: AB

THIS DRAWING IS UNPUBLISHED. RELEASED FOR PUBLICATION. COPYRIGHT copyright_d81e- ALL RIGHTS RESERVED.

REVISIONS				
P	LTN	DESCRIPTION	DATE	APVD
-	-	SEE SHEET 1	-	-

FINISH	DIM_F	DIM_D	DIM_C	B SPACES	DIM_E	NO OF POSN	PART NUMBER	FINISH	DIM_F	DIM_D	DIM_C	B SPACES	DIM_E	NO OF POSN	PART NUMBER
8	19.69	39.37	41.91	33	46.48	68	8-104069-8	7	19.69	39.37	41.91	33	46.48	68	3-104069-8
	29.85	59.69	62.23	49	66.80	100	8-104069-7		29.85	59.69	62.23	49	66.80	100	3-104069-7
	20.96	41.91	44.45	35	49.02	72	8-104069-6		20.96	41.91	44.45	35	49.02	72	3-104069-6
	-	24.13	26.67	21	31.24	44	8-104069-5		-	24.13	26.67	21	31.24	44	3-104069-5
	-	17.78	20.32	16	24.89	34	8-104069-4		-	17.78	20.32	16	24.89	34	3-104069-4
	-	12.7	15.24	12	19.81	26	8-104069-3		-	12.7	15.24	12	19.81	26	3-104069-3
	-	11.43	13.97	11	18.54	24	8-104069-2		-	11.43	13.97	11	18.54	24	3-104069-2
	-	6.35	8.89	7	13.46	16	8-104069-1		-	6.35	8.89	7	13.46	16	3-104069-1
	-	-	7.62	6	12.19	14	8-104069-0		-	-	7.62	6	12.19	14	3-104069-0
	-	-	6.35	5	10.92	12	7-104069-9		-	-	6.35	5	10.92	12	2-104069-9
	-	-	3.81	3	8.38	8	7-104069-8		-	-	3.81	3	8.38	8	2-104069-8
	17.15	34.29	36.83	29	41.40	60	7-104069-7		17.15	34.29	36.83	29	41.40	60	2-104069-7
	-	21.59	24.13	19	28.70	40	7-104069-6		-	21.59	24.13	19	28.70	40	2-104069-6
	-	15.24	17.78	14	22.35	30	7-104069-5		-	15.24	17.78	14	22.35	30	2-104069-5
	-	-	5.08	4	9.65	10	7-104069-4		-	-	5.08	4	9.65	10	2-104069-4
23.50	46.99	49.53	39	54.10	80	7-104069-3	23.50	46.99	49.53	39	54.10	80	2-104069-3		
-	27.94	30.48	24	35.05	50	7-104069-2	-	27.94	30.48	24	35.05	50	2-104069-2		
-	8.89	11.43	9	16.00	20	7-104069-1	-	8.89	11.43	9	16.00	20	2-104069-1		
6	19.69	39.37	41.91	33	46.48	68	6-104069-8	4	19.69	39.37	41.91	33	46.48	68	1-104069-8
	29.85	59.69	62.23	49	66.80	100	6-104069-7		29.85	59.69	62.23	49	66.80	100	1-104069-7
	20.96	41.91	44.45	35	49.02	72	6-104069-6		20.96	41.91	44.45	35	49.02	72	1-104069-6
	-	24.13	26.67	21	31.24	44	6-104069-5		-	24.13	26.67	21	31.24	44	1-104069-5
	-	17.78	20.32	16	24.89	34	6-104069-4		-	17.78	20.32	16	24.89	34	1-104069-4
	-	12.7	15.24	12	19.81	26	6-104069-3		-	12.7	15.24	12	19.81	26	1-104069-3
	-	11.43	13.97	11	18.54	24	6-104069-2		-	11.43	13.97	11	18.54	24	1-104069-2
	-	6.35	8.89	7	13.46	16	6-104069-1		-	6.35	8.89	7	13.46	16	1-104069-1
	-	-	7.62	6	12.19	14	6-104069-0		-	-	7.62	6	12.19	14	1-104069-0
	-	-	6.35	5	10.92	12	5-104069-9		-	-	6.35	5	10.92	12	104069-9
	-	-	3.81	3	8.38	8	5-104069-8		-	-	3.81	3	8.38	8	104069-8
	17.15	34.29	36.83	29	41.40	60	5-104069-7		17.15	34.29	36.83	29	41.40	60	104069-7
	-	21.59	24.13	19	28.70	40	5-104069-6		-	21.59	24.13	19	28.70	40	104069-6
	-	15.24	17.78	14	22.35	30	5-104069-5		-	15.24	17.78	14	22.35	30	104069-5
	-	-	5.08	4	9.65	10	5-104069-4		-	-	5.08	4	9.65	10	104069-4
23.50	46.99	49.53	39	54.10	80	5-104069-3	23.50	46.99	49.53	39	54.10	80	104069-3		
-	27.94	30.48	24	35.05	50	5-104069-2	-	27.94	30.48	24	35.05	50	104069-2		
-	8.89	11.43	9	16.00	20	5-104069-1	-	8.89	11.43	9	16.00	20	104069-1		

THIS DRAWING IS A CONTROLLED DOCUMENT.

DIMENSIONS: mm
 TOLERANCES UNLESS OTHERWISE SPECIFIED:
 0 PLC ±0.3
 2 PLC ±0.13
 3 PLC ±0.13
 4 PLC ±0.13
 ANGLES ±0.1°
 FINISH #1*

DWN: RAVI.S 18MAY2017
 CHK: J. OLSON 18MAY2017
 APVD: J. OLSON 18MAY2017

STE TE Connectivity
 NAME: HEADER ASSEMBLY, RIGHT ANGLE, DOUBLE ROW, W/SIDE & END LATCHES, AMPMODU System 50
 PRODUCT SPEC: 108-1093
 APPLICATION SPEC: 114-25031

MATERIAL: -
 WEIGHT: -
 CUSTOMER DRAWING

SIZE: A1
 CAGE CODE: -
 DRAWING NO: 104069
 RESTRICTED TO: -
 SCALE: 1:1
 SHEET: 2 OF 2
 REV: AB

Данный компонент на территории Российской Федерации

Вы можете приобрести в компании MosChip.

Для оперативного оформления запроса Вам необходимо перейти по данной ссылке:

<http://moschip.ru/get-element>

Вы можете разместить у нас заказ для любого Вашего проекта, будь то серийное производство или разработка единичного прибора.

В нашем ассортименте представлены ведущие мировые производители активных и пассивных электронных компонентов.

Нашей специализацией является поставка электронной компонентной базы двойного назначения, продукции таких производителей как XILINX, Intel (ex.ALTERA), Vicor, Microchip, Texas Instruments, Analog Devices, Mini-Circuits, Amphenol, Glenair.

Сотрудничество с глобальными дистрибьюторами электронных компонентов, предоставляет возможность заказывать и получать с международных складов практически любой перечень компонентов в оптимальные для Вас сроки.

На всех этапах разработки и производства наши партнеры могут получить квалифицированную поддержку опытных инженеров.

Система менеджмента качества компании отвечает требованиям в соответствии с ГОСТ Р ИСО 9001, ГОСТ РВ 0015-002 и ЭС РД 009

Офис по работе с юридическими лицами:

105318, г.Москва, ул.Щербаковская д.3, офис 1107, 1118, ДЦ «Щербаковский»

Телефон: +7 495 668-12-70 (многоканальный)

Факс: +7 495 668-12-70 (доб.304)

E-mail: info@moschip.ru

Skype отдела продаж:

moschip.ru

moschip.ru_4

moschip.ru_6

moschip.ru_9