

SPFJ SERIES FUSE

1000 VDC • 125 - 450A



Description

The SPFJ series is the smallest 1000VDC 125-450A photovoltaic fuse available in the market. The SPFJ series is manufactured in Class J case sizes that allows for both fuseholder and busbar mounting configuration. The SPFJ meets both UL and IEC requirements.

Features/Benefits

- Meets both UL and IEC photovoltaic standards
- Small footprint reduces panel size
- Full-range PV time-current characteristic
- Flexibility of fuseholder or busbar mounting
- Higher amperage solar fuses in standard sizes
- UL Listed Class J branch and feeder circuit rated

Specifications

- Voltage Ratings:** 1000 VDC
- Interrupting Rating:** AC: 200 kAIC;
DC: 125-200 A: 20 kAIC
250-400 A: 10 kAIC
450 A: 20 kAIC
- Amperage:** 125, 160, 200, 250, 300, 350, 400, 450
- Approvals:** UL 2579 Listed
UL 248-8, Class J
C UL (Approval on Class J fuse—no PV standard)
VDE certifications to IEC 60269-6 in progress
- Material:** Body-Melamine
End Bells-Copper Alloy
- Environmental:** RoHS Compliant
- Country of Origin:** Mexico

Applications

- Inverters
- Re-combiner boxes

Recommended Fuseholder

LFJ 1000VDC Solar Series

Dimensions in mm (inches)

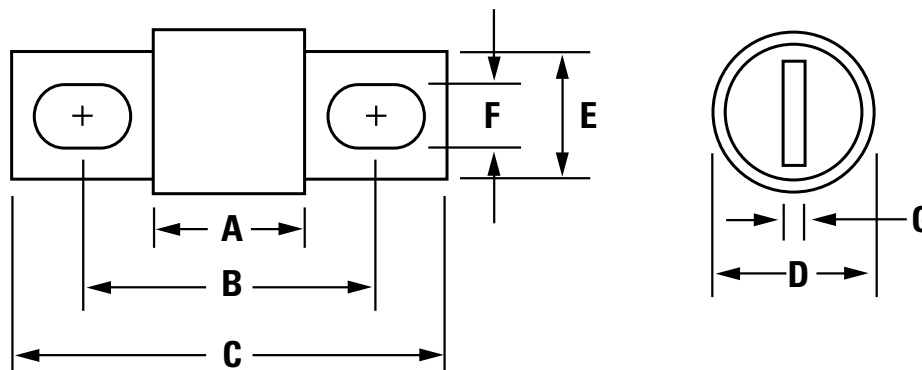

AMPERAGE	DIMENSIONS IN INCHES (MM)						
	A	B	C	D	E	F	G
125-200	3 (76.2)	4 11/32 (110.19)	5 21/32 (144.02)	1 1/2 (38.1)	1 1/8 (28.6)	9/32 (7.1)	3/16 (4.8)
250-400	3 3/8 (85.7)	5 1/4 (133.35)	7 1/8 (181.0)	2 (50.8)	1 5/8 (41.3)	13/32 (10.3)	1/4 (6.4)
450	3 3/4 (95.3)	5.98 (151.99)	8 (203.2)	2 1/2 (63.5)	2 (50.8)	17/32 (13.5)	3/8 (9.5)



Look for this logo to indicate products that are used in solar applications. Visit our website www.littelfuse.com/solar for the latest updates on approvals, certifications, codes and standards.

SPFJ SERIES FUSE

Ordering Information

PART NUMBER	ORDERING NUMBER	AMPERAGE	UPC	AGENCY APPROVALS					
				UL	VDE*	CE	ROHS	CCC*	C UL°
SPFJ 125	SPFJ125.X	125	07945894924	●	●	●	●	●	●
SPFJ 160	SPFJ160.X	160	07945894925	●	●	●	●	●	●
SPFJ 200	SPFJ200.X	200	07945894926	●	●	●	●	●	●
SPFJ 250	SPFJ250.X	250	07945894927	●	●	●	●	●	●
SPFJ 300	SPFJ300.X	300	07945894928	●	●	●	●	●	●
SPFJ 350	SPFJ350.X	350	07945894929	●	●	●	●	●	●
SPFJ 400	SPFJ400.X	400	07945894930	●	●	●	●	●	●
SPFJ 450	SPFJ450.X	450	07945894931	●	●	●	●	●	●

Electrical Specifications

ORDERING NUMBER	AMPERAGE RATING	VOLTAGE RATING		INTERRUPTING RATING		TOTAL CLEARING I ² T (A ² SEC) 100 kA (600Vac)	TOTAL CLEARING I ² T (A ² SEC) 10 kA (1000Vdc)	TOTAL CLEARING I ² T (A ² SEC) 20 kA (1000Vdc)
		AC	DC	AC	DC			
SPFJ125.X	125	600	1000	200 kA	20 kA	24750	17391	23529
SPFJ160.X	160	600	1000	200 kA	20 kA	60100	38771	47465
SPFJ200.X	200	600	1000	200 kA	20 kA	108000	66151	79642
SPFJ250.X	250	600	1000	200 kA	10 kA	85900	55897	N/A
SPFJ300.X	300	600	1000	200 kA	10 kA	143000	91129	N/A
SPFJ350.X	350	600	1000	200 kA	10 kA	232000	170863	N/A
SPFJ400.X	400	600	1000	200 kA	10 kA	400500	287094	N/A
SPFJ450.X	450	600	1000	200 kA	20 kA	565333	401687	400916

ORDERING NUMBER	AMPERAGE RATING	NOM COLD RESISTANCE (Ohm)	MELTING I ² T (10KA dc) (1000Vdc)	MELTING I ² T (20KA dc) (1000Vdc)	WATTS LOSS AT 100% RATED CURRENT (W)	WATTS LOSS AT 80% RATED CURRENT (W)	WATTS LOSS AT 70% RATED CURRENT (W)
SPFJ125.X	125	0.964	6863	5824	23.00	12.60	9.04
SPFJ160.X	160	0.613	19053	19368	22.77	12.67	9.15
SPFJ200.X	200	0.460	34053	32502	27.40	15.09	10.87
SPFJ250.X	250	0.485	31022	N/A	49.17	26.20	20.59
SPFJ300.X	300	0.367	59201	N/A	52.90	28.32	20.02
SPFJ350.X	350	0.285	109799	N/A	54.48	29.31	20.99
SPFJ400.X	400	0.236	198654	N/A	58.40	31.47	22.21
SPFJ450.X	450	0.187	317627	201877	50.55	28.68	20.79

* In Progress

° C UL Approval on Class J fuse (no CSA PV standard exists)

SPFJ SERIES FUSE

Electrical Specification – Agency Requirements

ORDERING NUMBER.	AMPERAGE	OPENING TIME (MINUTES)				
		100% of Amp Rating per UL	113% of Amp Rating per IEC	135% of Amp Rating per UL	145% of Amp Rating per IEC	200% of Amp Rating per UL
SPFJ125.X	125	Temperature Stabilization	120 Min	120 Max	120 Max	10 Max
SPFJ160.X	160		180 Min		180 Max	
SPFJ200.X	200					
SPFJ250.X	250					
SPFJ300.X	300					
SPFJ350.X	350					
SPFJ400.X	400					
SPFJ450.X	450		240 Min		240 Max	14 Max

Temperature Derating Curve

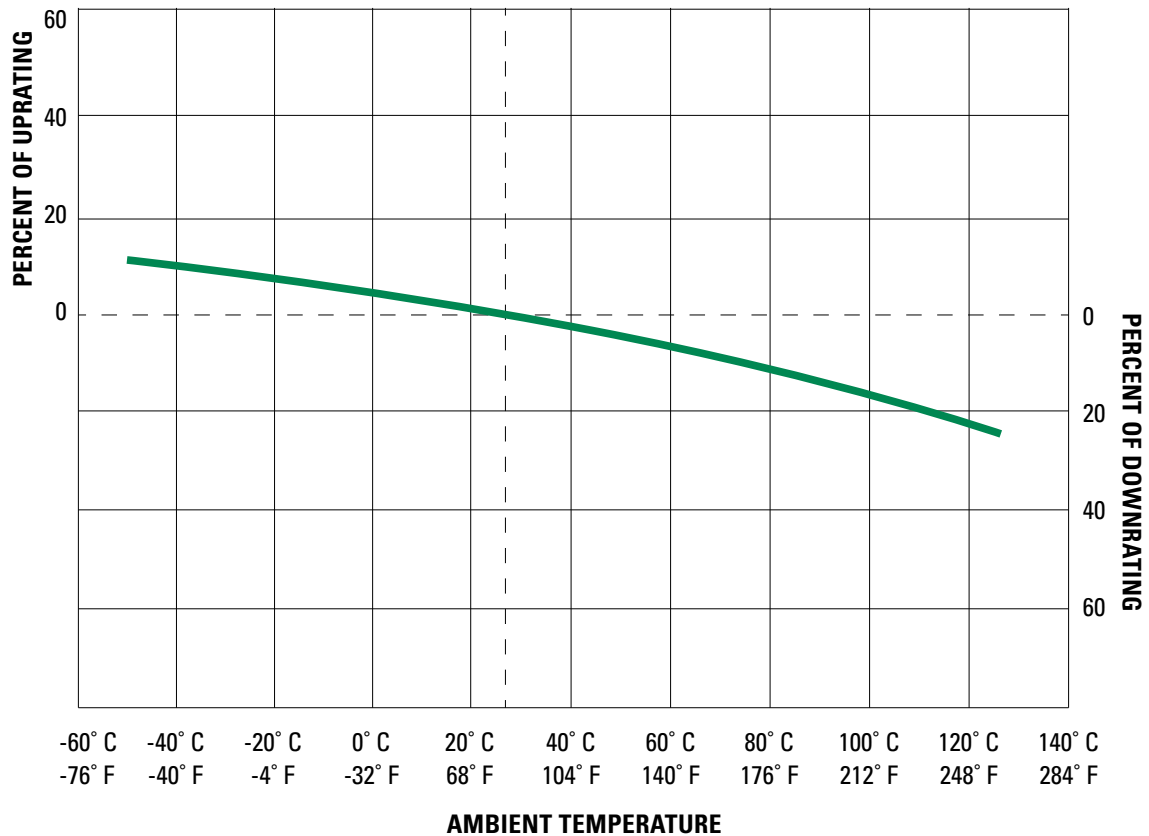

SPFJ SERIES FUSE

Recommended Torque Values For Bus Bar Mounting

RECOMMENDED TORQUE VALUES FOR BUSS BAR MOUNTING FUSE		
ORDERING NUMBER	FUSE TORQUE—METRIC (STANDARD)	HARDWARE SIZE—METRIC (STANDARD)*
SPFJ125.X	7.3 N•m (65 in-lb)	6mm (1/4 -20)
SPFJ160.X	7.3 N•m (65 in-lb)	6mm (1/4 -20)
SPFJ200.X	7.3 N•m (65 in-lb)	6mm (1/4 -20)
SPFJ250.X	19.2 N•m (170 in-lb)	10mm (3/8 -16)
SPFJ300.X	19.2 N•m (170 in-lb)	10mm (3/8 -16)
SPFJ350.X	19.2 N•m (170 in-lb)	10mm (3/8 -16)
SPFJ400.X	19.2 N•m (170 in-lb)	10mm (3/8 -16)
SPFJ450.X	19.2 N•m (170 in-lb)	12mm (7/16 -14)

* Recommended minimum hardware grade 2 or class 5.8



For fuseholder information, drawings and specifications visit www.littelfuse.com/solar

SPFJ SERIES FUSE

TIME CURRENT CURVE

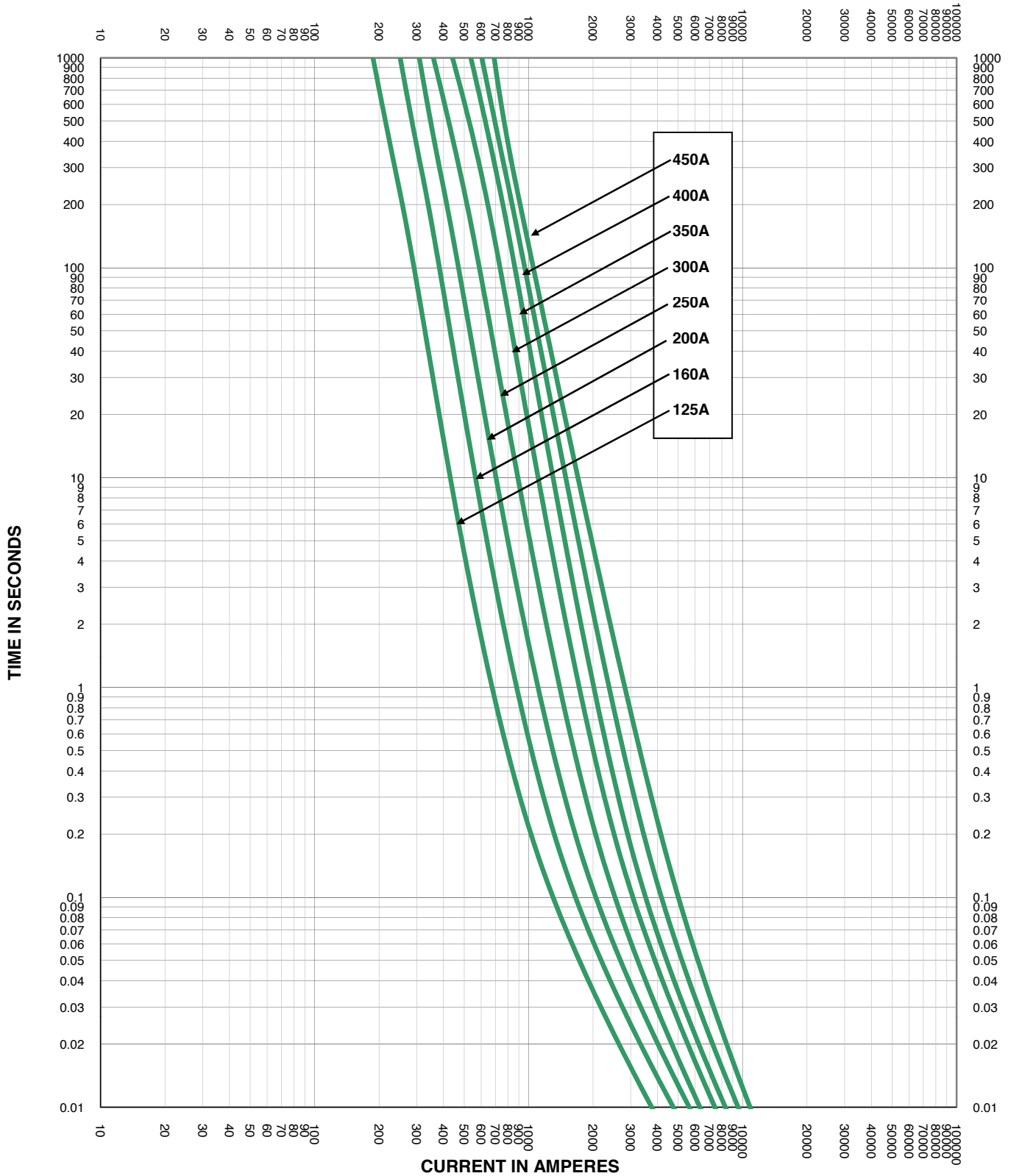

SPFJ SERIES FUSE

PEAK LET-THRU CHARACTERISTIC CURVES

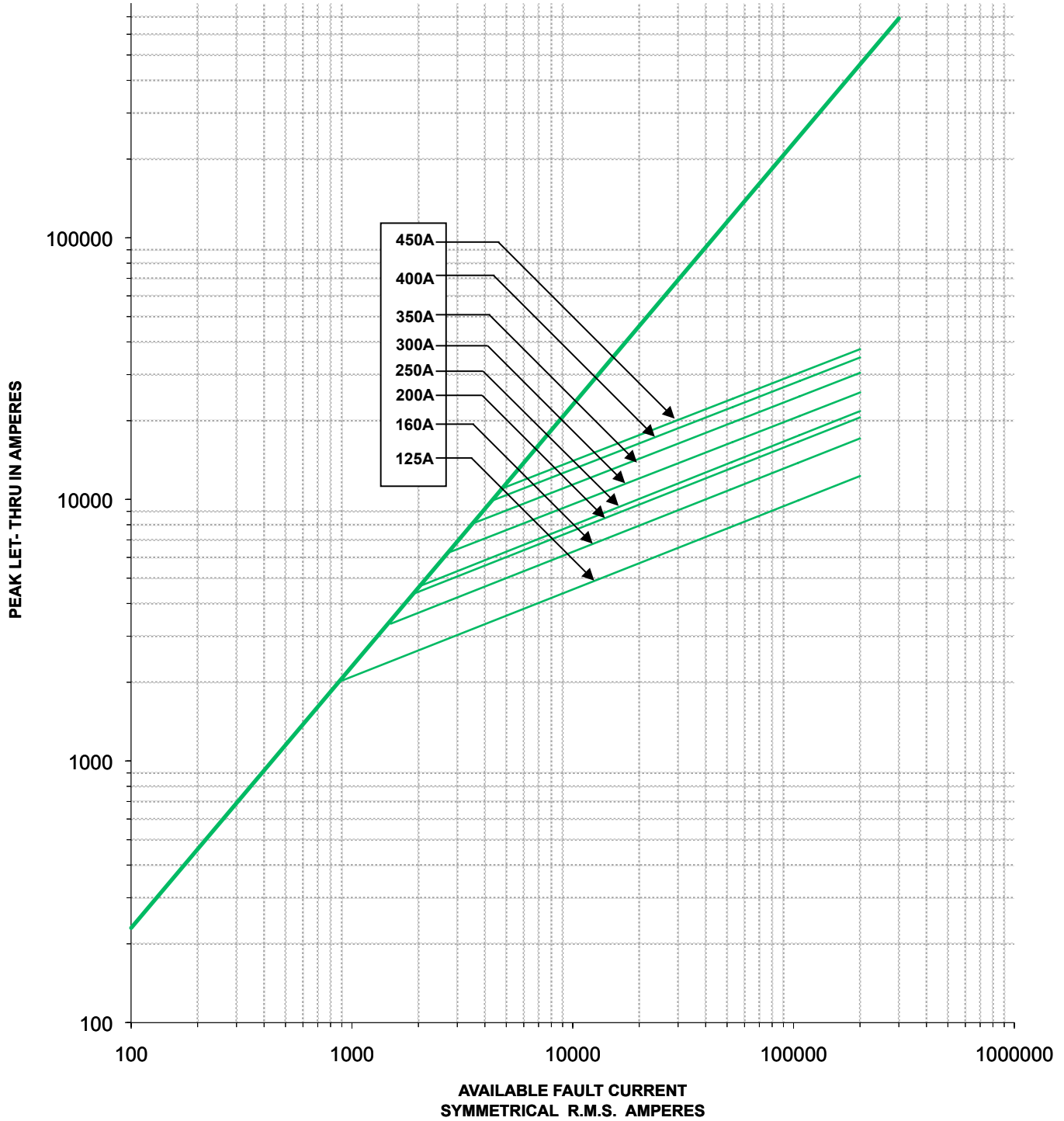

Данный компонент на территории Российской Федерации

Вы можете приобрести в компании MosChip.

Для оперативного оформления запроса Вам необходимо перейти по данной ссылке:

<http://moschip.ru/get-element>

Вы можете разместить у нас заказ для любого Вашего проекта, будь то серийное производство или разработка единичного прибора.

В нашем ассортименте представлены ведущие мировые производители активных и пассивных электронных компонентов.

Нашей специализацией является поставка электронной компонентной базы двойного назначения, продукции таких производителей как XILINX, Intel (ex.ALTERA), Vicor, Microchip, Texas Instruments, Analog Devices, Mini-Circuits, Amphenol, Glenair.

Сотрудничество с глобальными дистрибьюторами электронных компонентов, предоставляет возможность заказывать и получать с международных складов практически любой перечень компонентов в оптимальные для Вас сроки.

На всех этапах разработки и производства наши партнеры могут получить квалифицированную поддержку опытных инженеров.

Система менеджмента качества компании отвечает требованиям в соответствии с ГОСТ Р ИСО 9001, ГОСТ РВ 0015-002 и ЭС РД 009

Офис по работе с юридическими лицами:

105318, г.Москва, ул.Щербаковская д.3, офис 1107, 1118, ДЦ «Щербаковский»

Телефон: +7 495 668-12-70 (многоканальный)

Факс: +7 495 668-12-70 (доб.304)

E-mail: info@moschip.ru

Skype отдела продаж:

moschip.ru

moschip.ru_4

moschip.ru_6

moschip.ru_9