

150mA, 75V Switching Diode

FEATURES

- Low power loss, high efficiency
- Ideal for automated placement
- High surge current capability
- Moisture sensitivity level: level 1, per J-STD-020
- Compliance to RoHS directive 2011/65/EU and in accordance to WEEE 2002/96/EC
- Halogen-free according to IEC 61249-2-21

APPLICATIONS

- Switching mode power supply (SMPS)
- Adapters
- Lighting application
- On-board DC/DC converter

MECHANICAL DATA

- Case: SOD-123F
- Molding compound meets UL 94 V-0 flammability rating
- Terminal: Matte tin plated leads, solderable per J-STD-002
- Meet JESD 201 class 1A whisker test
- Polarity: Indicated by cathode band
- Weight: 8.85 ± 0.5mg

KEY PARAMETERS		
PARAMETER	VALUE	UNIT
I_F	150	mA
V_{RRM}	75	V
I_{FSM}	2	A
V_F at $I_F=100mA$	1.00	V
T_J Max.	150	°C
Package	SOD-123F	
Configuration	Single die	



ABSOLUTE MAXIMUM RATINGS ($T_A = 25^\circ\text{C}$ unless otherwise noted)				
PARAMETER		SYMBOL	VALUE	UNIT
Marking code on the device	1N4148W		D1	
	1N4448W		D2	
	1N914BW		D3	
Power dissipation		P_D	400	mW
Reverse voltage		V_R	100	V
Repetitive peak reverse voltage		V_{RRM}	75	V
Forward current		I_F	150	mA
Repetitive peak forward current		I_{FRM}	300	mA
Non-repetitive peak forward surge current @ $t=1.0\mu\text{s}$		I_{FSM}	2	A
Junction temperature range		T_J	-65 to +150	°C
Storage temperature range		T_{STG}	-65 to +150	°C

THERMAL PERFORMANCE			
PARAMETER	SYMBOL	TYP	UNIT
Junction-to-ambient thermal resistance	$R_{\theta JA}$	450	$^{\circ}\text{C/W}$

ELECTRICAL SPECIFICATIONS ($T_A = 25^{\circ}\text{C}$ unless otherwise noted)						
PARAMETER		CONDITIONS	SYMBOL	MIN	MAX	UNIT
Forward voltage ⁽¹⁾	1N4448W, 1N914BW	$I_F = 5\text{mA}, T_J = 25^{\circ}\text{C}$	V_F	0.62	0.72	V
	1N4148W	$I_F = 10\text{mA}, T_J = 25^{\circ}\text{C}$		-	1.00	
	1N4448W, 1N914BW	$I_F = 100\text{mA}, T_J = 25^{\circ}\text{C}$		-	1.00	
Reverse voltage	$I_R = 100\mu\text{A}, T_J = 25^{\circ}\text{C}$		V_R	100	-	V
	$I_R = 5\mu\text{A}, T_J = 25^{\circ}\text{C}$			75	-	
Reverse leakage current ⁽²⁾	$V_R = 20\text{V}, T_J = 25^{\circ}\text{C}$		I_R	-	25	nA
	$V_R = 75\text{V}, T_J = 25^{\circ}\text{C}$			-	5	μA
Junction capacitance	1 MHz, $V_R = 0\text{V}$		C_J	-	4	pF
Reverse recovery time	$I_F = 10\text{mA}, I_R = 60\text{mA}, R_L = 100\Omega, I_{RR} = 1\text{mA}$		t_{rr}	-	4	ns

Notes:

1. Pulse test with $PW = 0.3\text{ ms}$
2. Pulse test with $PW = 30\text{ ms}$

ORDERING INFORMATION		
PART NO.	PACKAGE	PACKING
1N4148W RHG	SOD-123F	3K / 7" Reel
1N4148W RH	SOD-123F	3K / 7" Reel
1N4448W RHG	SOD-123F	3K / 7" Reel
1N4448W RH	SOD-123F	3K / 7" Reel
1N914BW RHG	SOD-123F	3K / 7" Reel
1N914BW RH	SOD-123F	3K / 7" Reel

CHARACTERISTICS CURVES

($T_A = 25^\circ\text{C}$ unless otherwise noted)

Fig.1 Typical Forward Characteristics

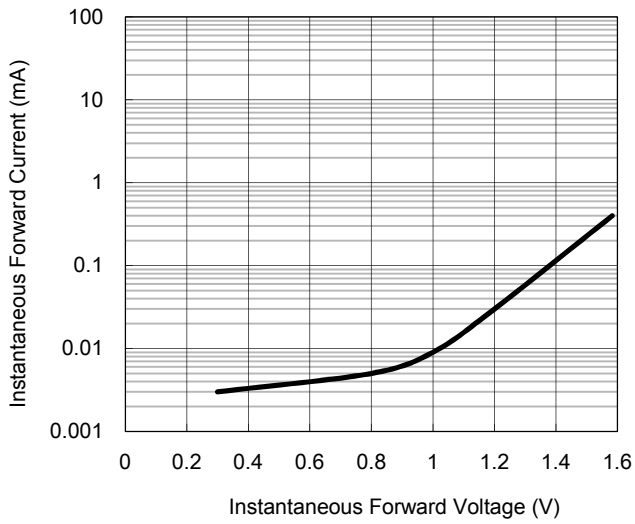

Fig.2 Reverse Current VS. Reverse Voltage

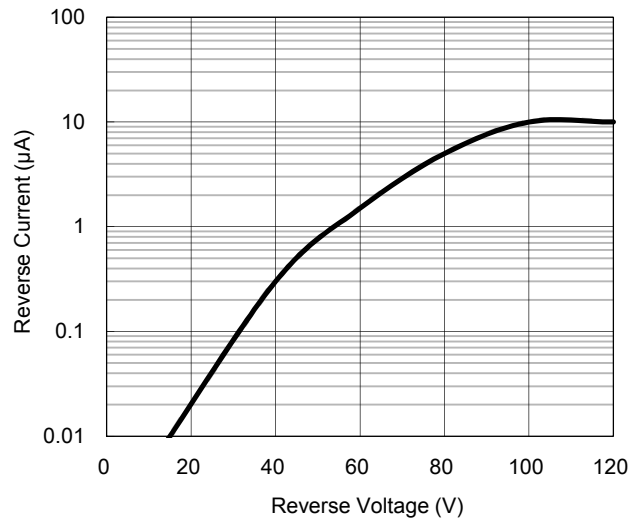

Fig.3 Admissible Power Dissipation Curve

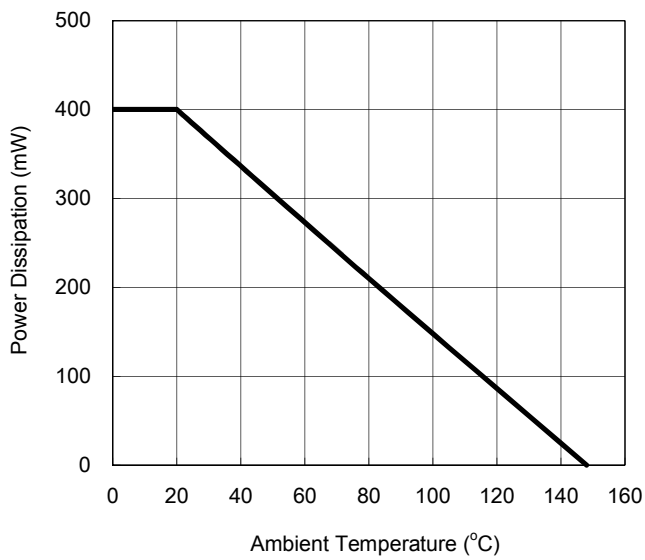
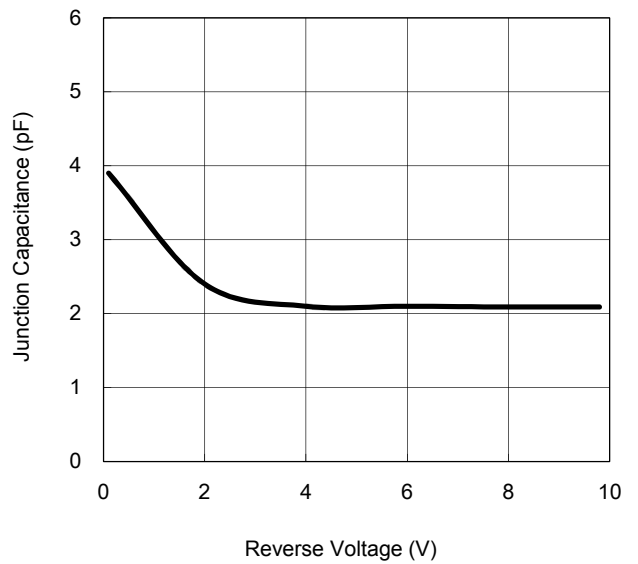

Fig.4 Typical Junction Capacitance



PACKAGE OUTLINE DIMENSION



DIM.	Unit (mm)		Unit (inch)	
	Min	Max	Min	Max
A	1.50	1.70	0.059	0.067
B	3.30	3.90	0.130	0.154
C	0.50	0.70	0.020	0.028
D	2.50	2.70	0.098	0.106
E	0.80	1.15	0.031	0.045
F	0.05	0.20	0.002	0.008

SUGGEST PAD LAYOUT

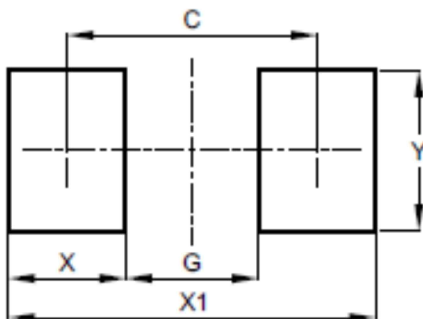

DIM.	Unit (mm)	Unit (inch)
	Typ.	Typ.
C	2.86	0.113
G	1.52	0.060
X	1.34	0.053
X1	4.20	0.165
Y	1.80	0.071

Notice

Specifications of the products displayed herein are subject to change without notice. TSC or anyone on its behalf, assumes no responsibility or liability for any errors or inaccuracies.

Information contained herein is intended to provide a product description only. No license, express or implied, to any intellectual property rights is granted by this document. Except as provided in TSC's terms and conditions of sale for such products, TSC assumes no liability whatsoever, and disclaims any express or implied warranty, relating to sale and/or use of TSC products including liability or warranties relating to fitness for a particular purpose, merchantability, or infringement of any patent, copyright, or other intellectual property right.

The products shown herein are not designed for use in medical, life-saving, or life-sustaining applications. Customers using or selling these products for use in such applications do so at their own risk and agree to fully indemnify TSC for any damages resulting from such improper use or sale.

Данный компонент на территории Российской Федерации

Вы можете приобрести в компании MosChip.

Для оперативного оформления запроса Вам необходимо перейти по данной ссылке:

<http://moschip.ru/get-element>

Вы можете разместить у нас заказ для любого Вашего проекта, будь то серийное производство или разработка единичного прибора.

В нашем ассортименте представлены ведущие мировые производители активных и пассивных электронных компонентов.

Нашей специализацией является поставка электронной компонентной базы двойного назначения, продукции таких производителей как XILINX, Intel (ex.ALTERA), Vicor, Microchip, Texas Instruments, Analog Devices, Mini-Circuits, Amphenol, Glenair.

Сотрудничество с глобальными дистрибьюторами электронных компонентов, предоставляет возможность заказывать и получать с международных складов практически любой перечень компонентов в оптимальные для Вас сроки.

На всех этапах разработки и производства наши партнеры могут получить квалифицированную поддержку опытных инженеров.

Система менеджмента качества компании отвечает требованиям в соответствии с ГОСТ Р ИСО 9001, ГОСТ РВ 0015-002 и ЭС РД 009

Офис по работе с юридическими лицами:

105318, г.Москва, ул.Щербаковская д.3, офис 1107, 1118, ДЦ «Щербаковский»

Телефон: +7 495 668-12-70 (многоканальный)

Факс: +7 495 668-12-70 (доб.304)

E-mail: info@moschip.ru

Skype отдела продаж:

moschip.ru

moschip.ru_4

moschip.ru_6

moschip.ru_9