

Three Phase Power Line Filters

*Excellent attenuation for high voltage impulse.
Epoxy molded for internal component reliability and
metal case provides effective EMI shielding. Ideal for
digital, industrial and automation equipment.*



Low Current/High PerformancePF80-PF81

Three-Phase Power Line Filters.....PF82-PF83

High PerformancePF84-PF89



Power Line Filters Three Phase

Low Current/High Performance



62-PMB/63-PMF Series

Features

- Excellent attenuation for high voltage impulse
- Effective for both balanced and unbalanced three-phase loads
- Metal case provides effective EMI shielding
- Epoxy molded for internal component reliability
- Compact and economical
- Excellent filtering characteristics for both normal and common mode
- Various current ratings available: 3, 5, 8 and 16 Amps
- Safety agency approvals pending
- Operating temperature: -25°C to +85°C (including temperature rise, see graph on page PF81)

Applications

- Digital equipment
- Industrial equipment (UPS, inverters and converters)
- Automation equipment
- Computerized washing machines

Circuit Diagram

62-PMB-050-6-12 (5 Amp Delta)

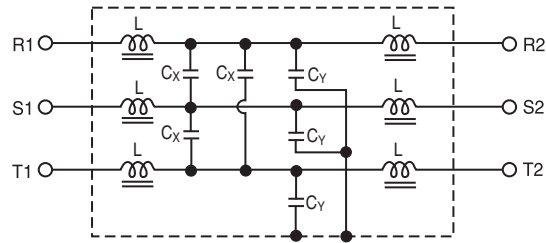

63-PMF-030-8-14 and 63-PMF-080-8-14 (3 and 8 Amp Wye)

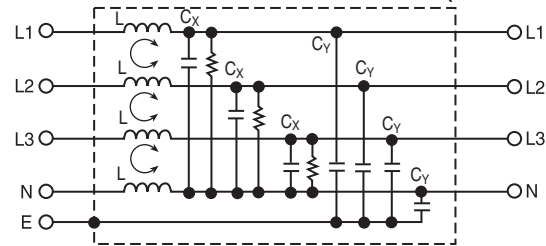

63-PMF-160-9-21 (16 Amp Wye)

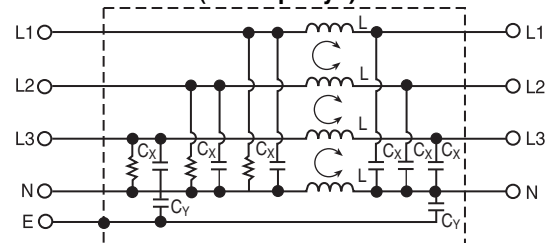

Specifications

Model	Rated Voltage (@ 50/60Hz)	Rated Current	Leakage Current (Max.)	Capacitance		Inductance (L ₁)	Temperature Rise (Max.)
				C _Y	C _X		
62-PMB-050-6-12	250VAC	5A	0.6mA	2200pF	0.22uF	115mH	45°C
63-PMF-030-8-14	480VAC	3A	1.0mA	4700pF (4X)	470uF (3X)	1.0mH (4X)	30°C
63-PMF-080-8-14		8A				0.74mH (4X)	40°C
63-PMF-160-9-21		16A	3.0mA	0.015uF (2X)	1.0uF (6X)	1.2mH (4X)	45°C

Note: Test Voltage 1500VAC one minute, line to ground.
 Insulation Resistance: 300 MΩ min. at 500VDC.
 Voltage Drop: 1V max. at rated current.
 Weight: 8.82 ounces (250 grams) for 63-PMF-030-8-14 and 63-PMF-080-8-14
 19.4 ounces (550 grams) for 62-PMB-050-6-12
 51.5 ounces (1450 grams) for 63-PMF-160-9-21

Power Line Filters Three Phase

Low Current/High Performance

62-PMB/63-PMF Series

62-PMB-050-6-12 (5 Amp)

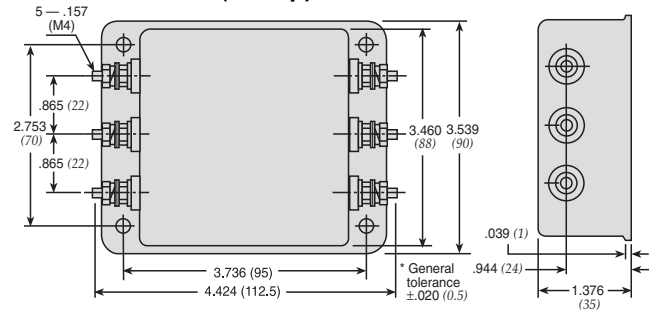

63-PMF-030-8-14 and 63-PMF-080-8-14 (3 and 8 Amp)

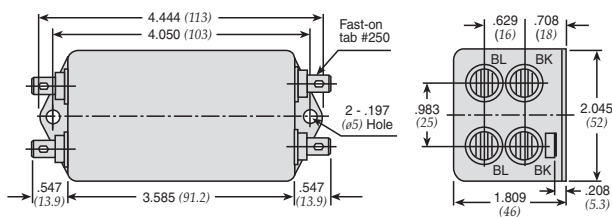

Dimensions in inches (mm)

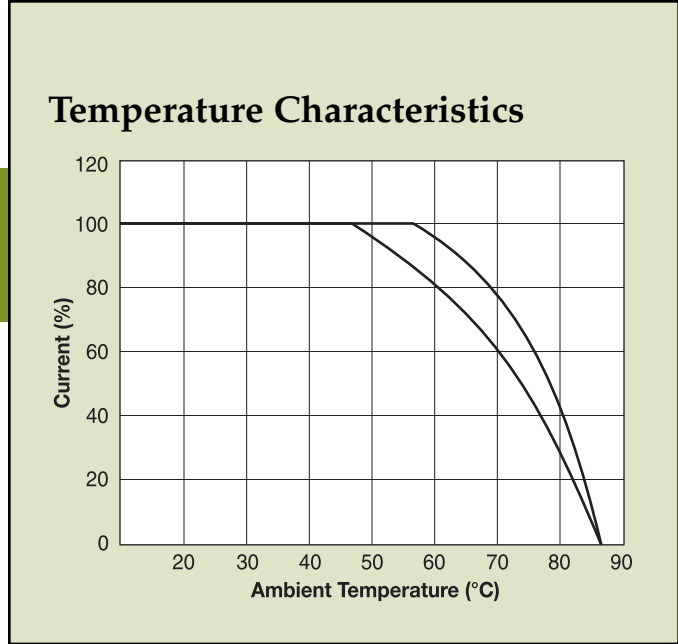

63-PMF-160-9-21 (16 Amp)

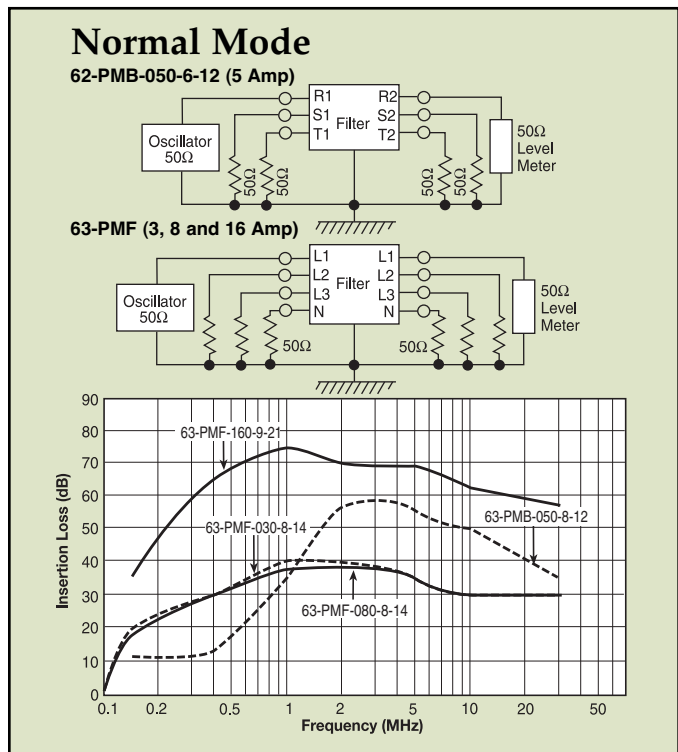
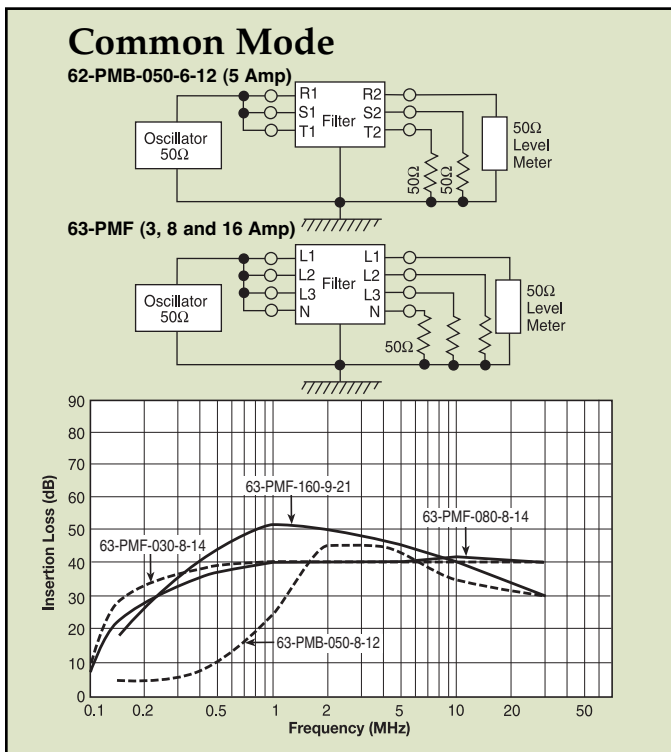
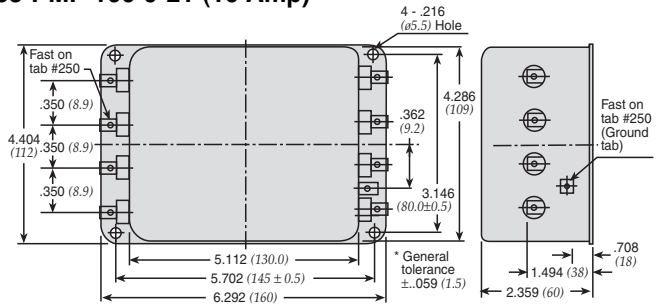

Power Line Filters Three Phase

13-PWF/PWL/PWB Series

Features

- Excellent attenuation for high voltage impulse
- Effective for both balanced and unbalanced three-phase loads
- Metal case provides effective EMI shielding
- Epoxy molded for internal component reliability
- Suitable for both Wye and Delta connection
- Excellent filtering characteristics for both normal and common mode
- Operating temperature: -40°C to +85°C
- Designed for 3-phase 4-line power supply systems

Applications

- Digital equipment
- Industrial equipment (UPS, inverters and converters)
- Automation equipment
- Computerized washing machines



Circuit Diagram

Circuit 1

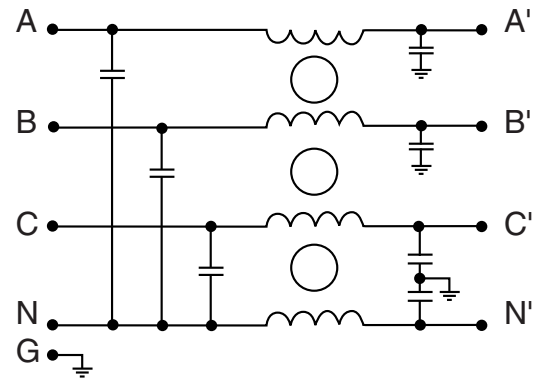

Circuit 2

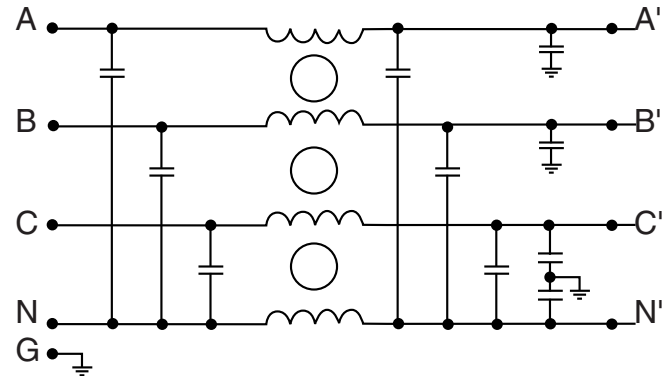

Specifications

Model	Rated Voltage (@ 50/60Hz)	Rated Current	Leakage Current (Max.)	Circuit Diagram	Figure	Temperature Rise (Max.)
13-PWF-005-12-H	440/250VAC	5A	1.5mA	1	A	30°C
13-PWL-005-12-C					B	
13-PWF-010-12-H		10A			A	
13-PWL-010-12-C					B	
13-PWB-010-12-D		2		30A	C	
13-PWB-015-12-D						
13-PWB-020-12-D						
13-PWB-025-12-D						
13-PWB-030-12-D						

Note: Test Voltage 1500VAC one minute, line to ground.
Insulation Resistance: 300 MΩ min. at 500VDC.
Voltage Drop: 1V max. at rated current.

Power Line Filters Three Phase

13-PWF/PWL/PWB Series

Figure A

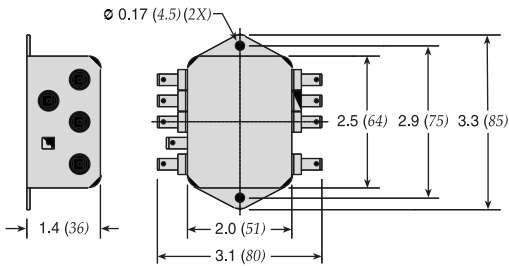

Dimensions in inches (mm)

Figure B

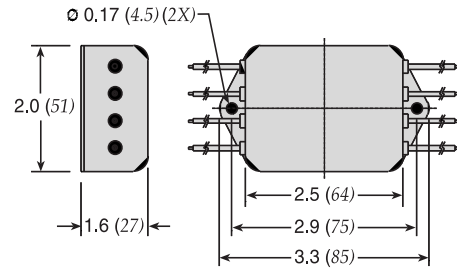
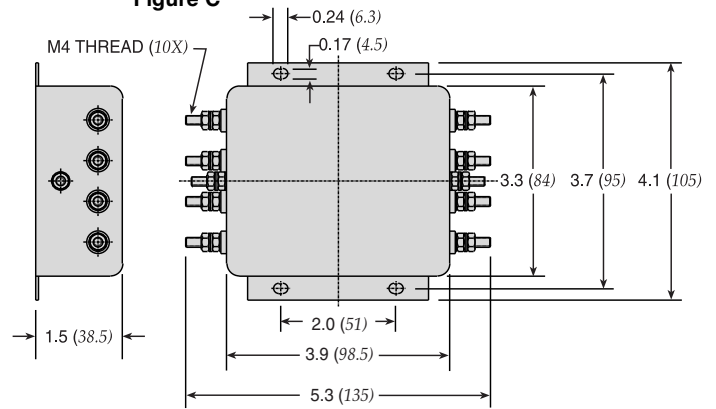
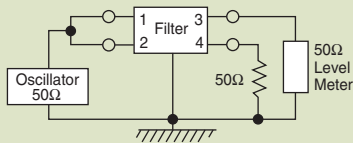

Figure C



Common Mode



13-PWF-005;-010;-PWL-005;-010;-PWB-010

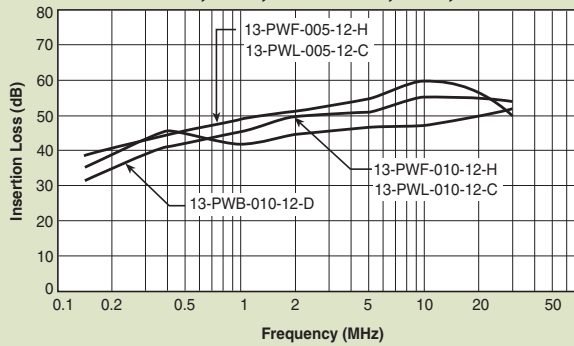

13-PWB-015;-020;-025;-030

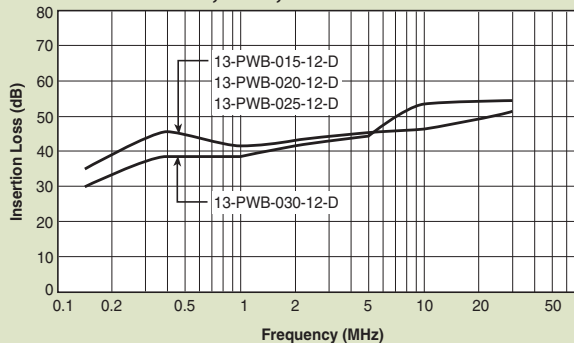

Normal Mode

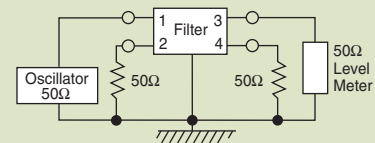

13-PWF-005;-010;-PWL-005;-010;-PWB-010

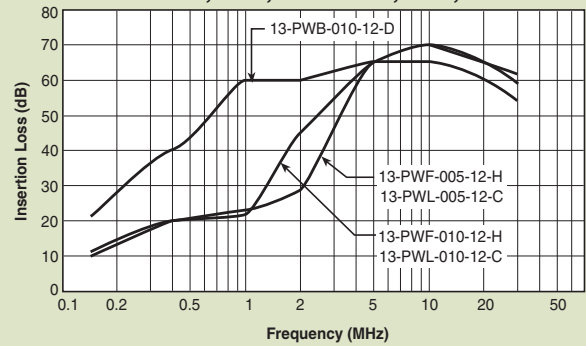

13-PWB-015;-020;-025;-030

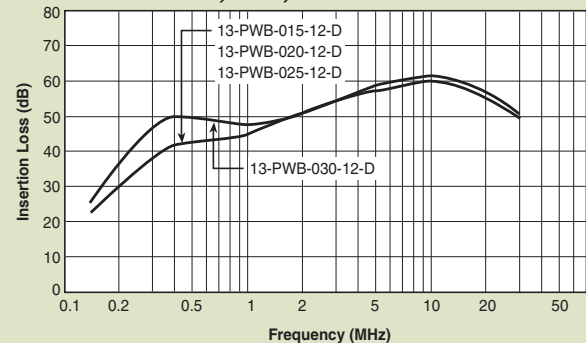

Power Line Filters Three Phase

High Performance

13-PDF/PDL/PDB Series

Features

- Excellent attenuation for high voltage impulse
- Effective for both balanced and unbalanced three-phase loads
- Metal case provides effective EMI shielding
- Epoxy molded for internal component reliability
- Compact and economical
- Excellent filtering characteristics for both normal and common mode
- Operating temperature: -40°C to +85°C
- Designed for 3-phase, 3-Delta connection system

Applications

- Digital equipment
- Industrial equipment (UPS, inverters and converters)
- Automation equipment
- Switching power supplies



Circuit Diagram

Circuit 1

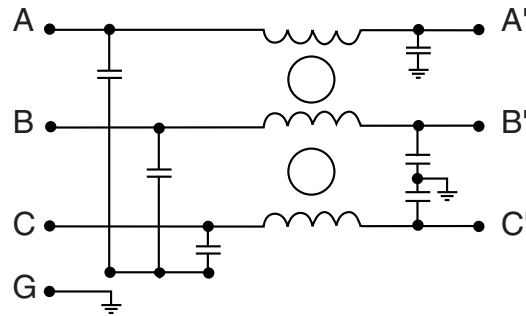

Circuit 2

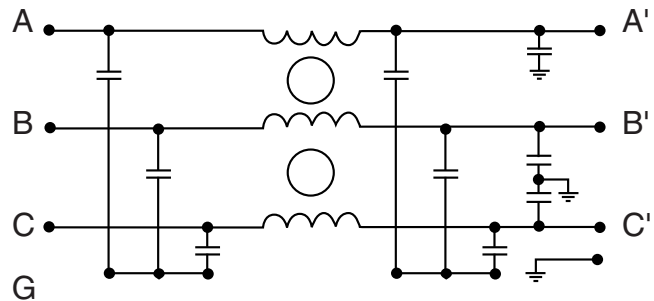

Specifications

Model	Rated Voltage (@ 50/60Hz)	Rated Current	Leakage Current (Max.)	Circuit Diagram	Figure	Temperature Rise (Max.)
13-PDF-005-11-J	440/250VAC	5A	1.5mA	1	A	30°C
13-PDL-005-11-D					B	
13-PDF-010-11-J		A				
13-PDL-010-11-D		B				
13-PDB-010-11-D		15A		2	C	
13-PDB-015-11-D						
13-PDB-020-11-D						
13-PDB-025-11-D						
13-PDB-030-11-D						

Note: Test Voltage 1500VAC one minute, line to ground.
Insulation Resistance: 300 MΩ min. at 500VDC.
Voltage Drop: 1V max. at rated current.

Power Line Filters Three Phase

High Performance

13-PDF/PDL/PDB Series

Figure A

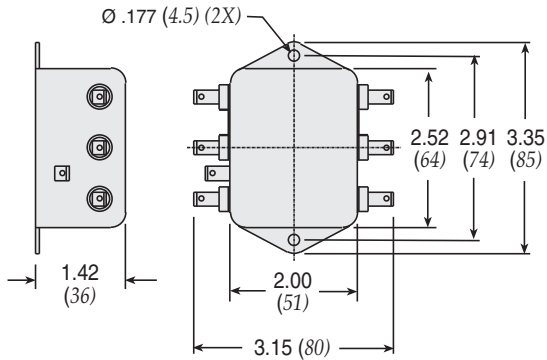

Dimensions in inches (mm)

Figure B

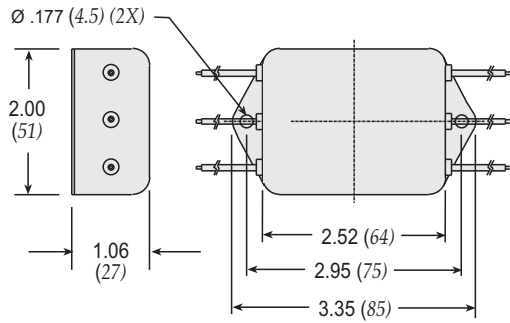
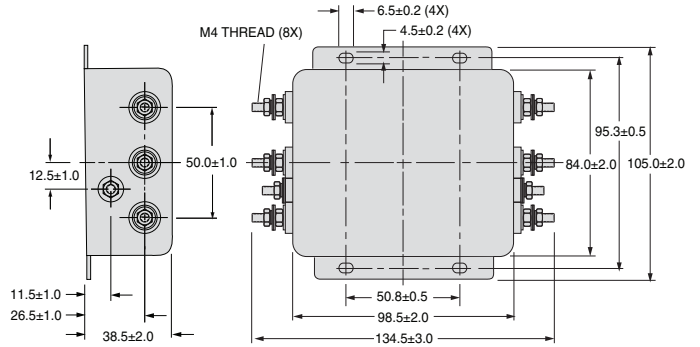
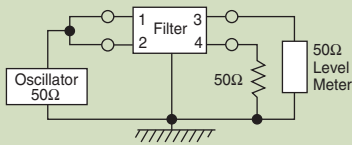

Figure C



Common Mode



13-PDF-005;-010; PDL-005;-010 PDB-010

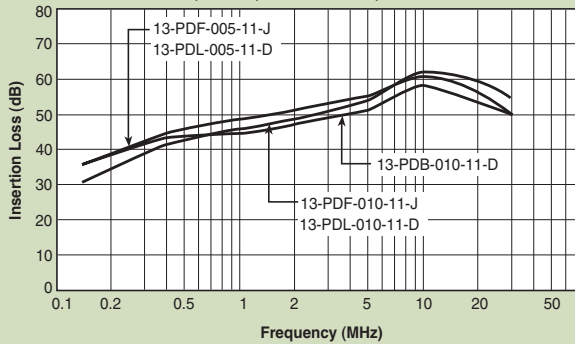

13-PDB-015;-020;-025;-030

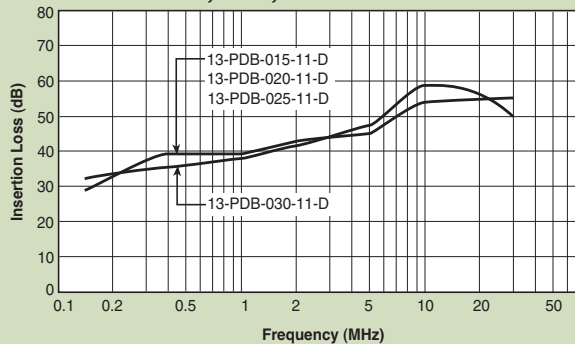

Normal Mode

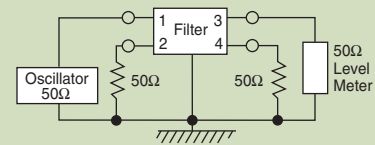

13-PDF-005;-010; PDL-005;-010 PDB-010

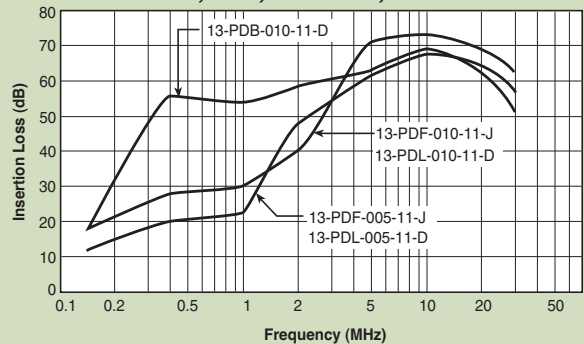

13-PDB-015;-020;-025;-030

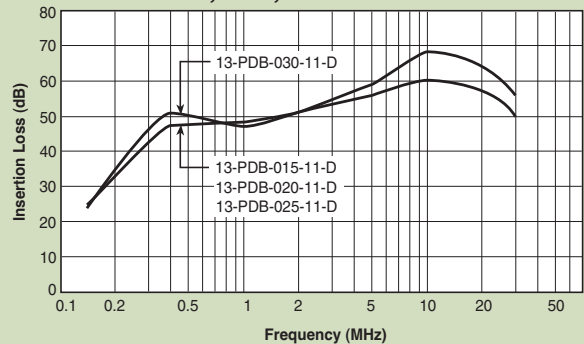

Power Line Filters Three Phase

High Performance



13-PWB Series

Features

- Excellent attenuation for high voltage impulse
- Metal case provides effective EMI shielding
- Epoxy molded for internal component reliability
- Excellent filtering characteristics for both normal and common mode
- Various current ratings available: from 5 to 150 Amps
- Operating temperature: -40°C to +85°C
- Designed for 3-phase, 4-line power systems

Applications

- Power supplies for data systems
- Industrial equipment (UPS, inverters and converters)
- Automation equipment
- Telecommunications systems and equipment

Circuit Diagram

Circuit 1

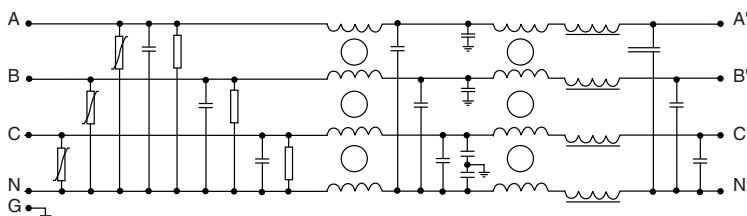

Circuit 2

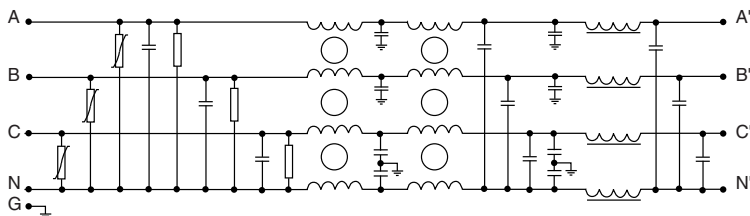

Specifications

Model	Rated Voltage (@ 50/60Hz)	Rated Current	Leakage Current (Max.)	Circuit Diagram	Temperature Rise (Max.)
13-PWB-005-12-A	480/277VAC	5A	4.5mA	1	30°C
13-PWB-010-12-B		10A			
13-PWB-020-12-B		20A			
13-PWB-035-12-C		35A			
13-PWB-050-13-C		50A	9.0mA	2	
13-PWB-080-14-D		80A	20mA		
13-PWB-100-14-D		100A			
13-PWB-150-14-E		150A			

Note: Test Voltage 1500VAC one minute, line to ground.
Insulation Resistance: 300 MΩ min. at 500VDC.
Voltage Drop: 1V max. at rated current.

Power Line Filters Three Phase

High Performance

13-PWB Series

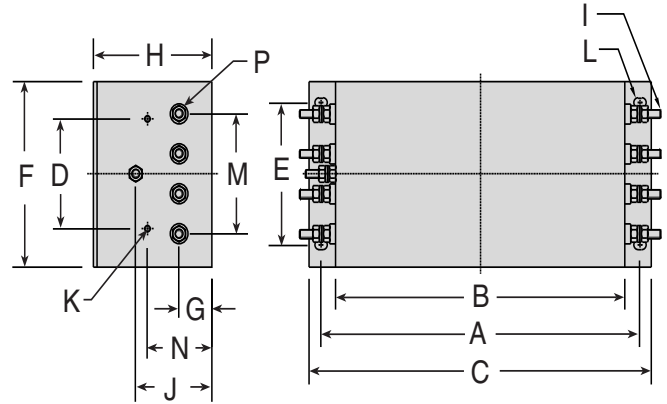

Dimensions

Dimensions in inches (mm)

Model	A	B	C	D	E	F	G	H	I	J	K	M	N	P	L			
13-PWB-005-12-A	7.2 (184)	6.3 (160)	7.9 (202)	2.4 (60)	1.7 (44)	3.5 (86)	.70 (18)	2.3 (58)	M4	1.5 (38)	-	-	-	M4	.25 x .37 (6.4 x 9.4)			
13-PWB-010-12-B	9.6 (243)	8.7 (220)	10.3 (261)			3.9 (100)	.98 (25)			3.5 (90)					1.8 (45)	M6	2.3 (58)	M4
13-PWB-020-12-B				2.4 (60)	1.5 (38)	M6		.25 x .38 (6.4 x 9.6)										
13-PWB-035-12-C				3.1 (81)	3.8 (96)				4.9 (125)		M8	2.4 (62)	3.4 (86)	2.2 (56)	M8		.25 x .38 (6.4 x 9.7)	
13-PWB-050-13-C	13.9 (354)	12.6 (320)	15.1 (384)	3.9 (99)	6.1 (155)	7.3 (185)	1.2 (30)	M8	M4	3.4 (86)						2.2 (56)	2.4 (61)	M8
13-PWB-080-14-D											7.5 (190)	8.7 (220)	1.4 (35)	3.9 (100)	.25 x .39 (6.4 x 9.9)			
13-PWB-100-14-D																		
13-PWB-150-14-E											M8	.25 x .36 (6.4 x 9.11)						

Common Mode

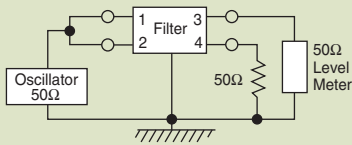

13-PWB-005;-010;-020;-035

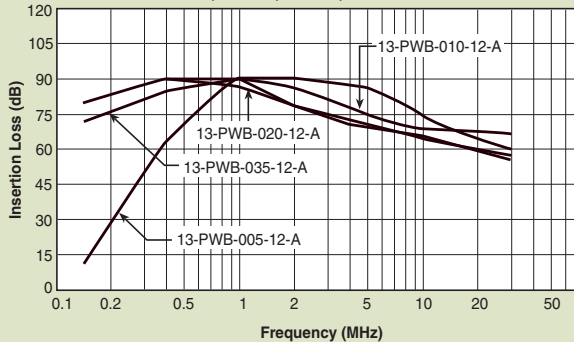

13-PWB-050;-080;-100;-150

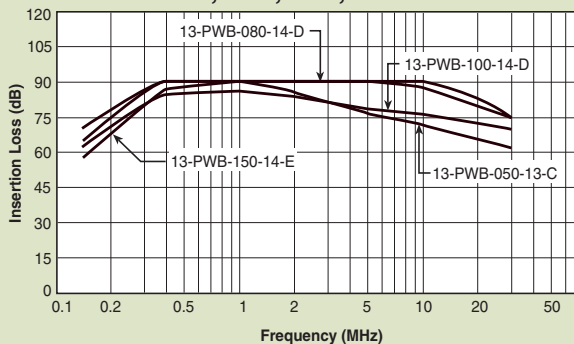

Normal Mode

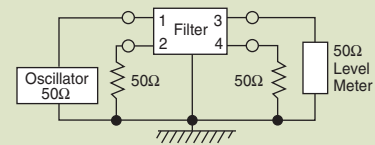

13-PWB-005;-010;-020;-035

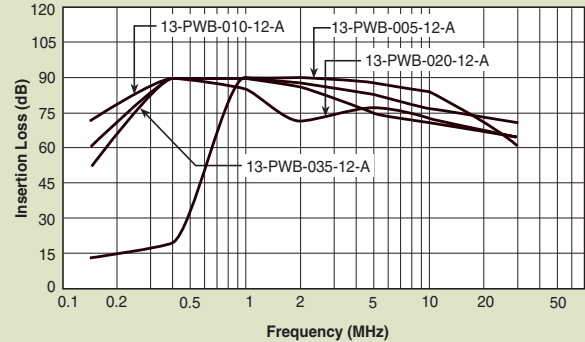

13-PWB-050;-080;-100;-150

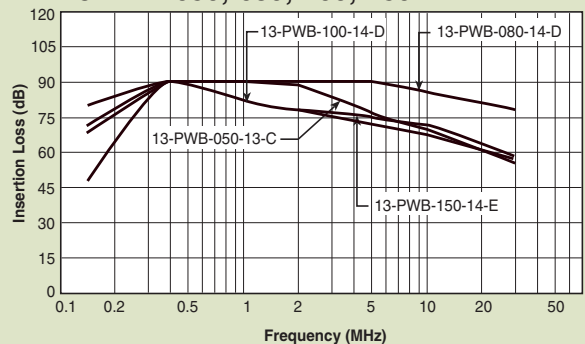

Power Line Filters Three Phase

High Performance



13-PDB Series

Features

- Excellent attenuation for high voltage impulse
- Metal case provides effective EMI shielding
- Epoxy molded for internal component reliability
- Excellent filtering characteristics for both normal and common mode
- Various current ratings available: from 5 to 200 Amps
- Operating temperature: -40°C to +85°C
- Designed for 3-phase, 3-line connection systems

Applications

- Digital equipment
- Industrial equipment (UPS, inverters and converters)

Circuit Diagram

Circuit 1

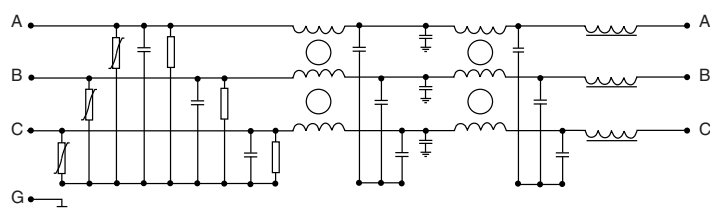

Circuit 2

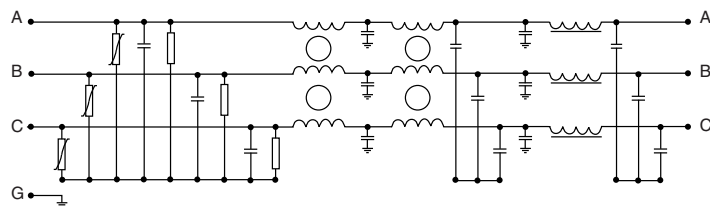

Specifications

Model	Rated Voltage (@ 50/60Hz)	Rated Current	Leakage Current (Max.)	Circuit Diagram	Temperature Rise (Max.)
13-PDB-005-12-A	480/277VAC	5A	4.5mA	1	30°C
13-PDB-010-12-A		10A			
13-PDB-020-12-B		20A			
13-PDB-035-12-B		35A			
13-PDB-050-12-B		50A			
13-PDB-080-13-C		80A	9.0mA	2	
13-PDB-100-14-C		100A			
13-PDB-150-14-C		150A			
13-PDB-200-14-D		150A			
		200A			

Note: Test Voltage 2250VDC one minute, line to ground.
Insulation Resistance: 500MΩ.

Power Line Filters Three Phase

High Performance

13-PDB Series

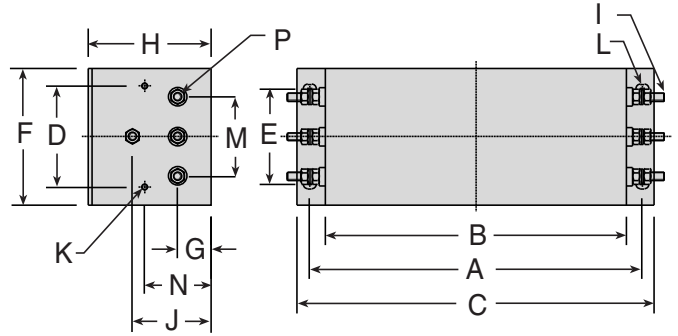

Dimensions

Dimensions in inches (mm)

Model	A	B	C	D	E	F	G	H	I	J	K	M	N	P	L
13-PDB-005-12-A	7.2 (184)	6.3 (160)	7.9 (202)	1.6 (42)	2.4 (60)	3.3 (86)	.70 (18)	2.3 (58)	M4	1.5 (38)	-	-	-	M4	.25 x .37 (6.4 x 9.4)
13-PDB-010-12-A															.25 x .37 (6.4 x 9.5)
13-PDB-020-12-B								3.5 (90)	M6	2.3 (58)	M4	2.9 (74)	1.9 (49)	M6	.25 x .38 (6.4 x 9.6)
13-PDB-035-12-B	9.6 (243)	8.7 (220)	10.3 (261)	2.3 (58)	2.7 (70)	3.9 (100)	.98 (25)								.25 x .38 (6.4 x 9.7)
13-PDB-050-12-B															.25 x .38 (6.4 x 9.8)
13-PDB-080-13-C					6.1 (155)	7.3 (185)	1.2 (30)		M8	2.4 (62)	M4	3.3 (86)	2.2 (56)	M8	.25 x .39 (6.4 x 9.9)
13-PDB-100-14-C	13.9 (354)	12.6 (320)	15.1 (384)	2.5 (66)				.25 x .36 (6.4 x 9.10)							
13-PDB-150-14-C								.25 x .36 (6.4 x 9.11)							
13-PDB-200-14-D					7.5 (190)	8.6 (220)	1.4 (35)	3.9 (100)							

Common Mode

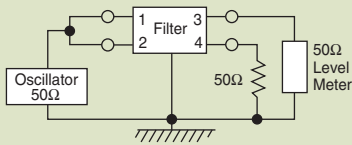

13-PDB-005;-010;-020;-035

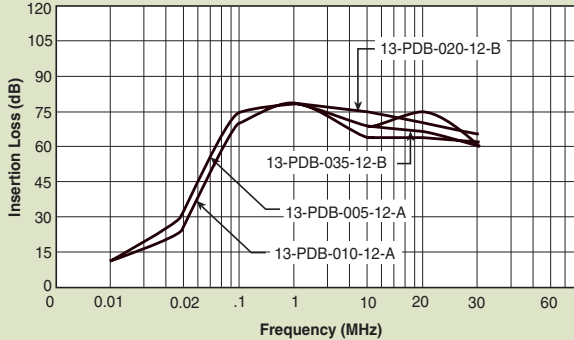

13-PDB-050;-080;-100;-150;-200

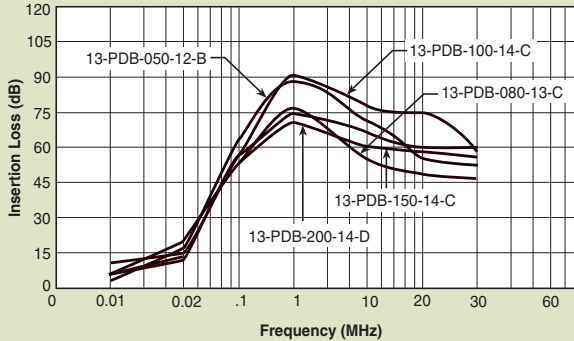

Normal Mode

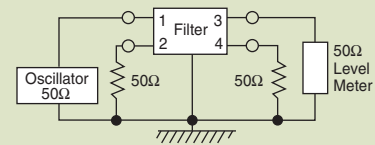

13-PDB-005;-010;-020;-035

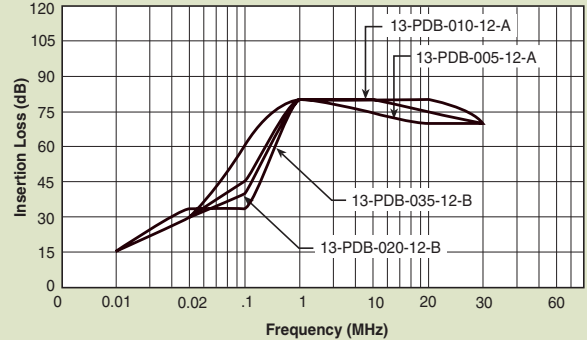

13-PDB-050;-080;-100;-150;-200

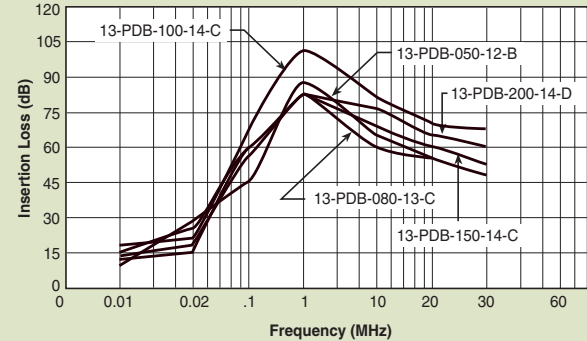

Данный компонент на территории Российской Федерации

Вы можете приобрести в компании MosChip.

Для оперативного оформления запроса Вам необходимо перейти по данной ссылке:

<http://moschip.ru/get-element>

Вы можете разместить у нас заказ для любого Вашего проекта, будь то серийное производство или разработка единичного прибора.

В нашем ассортименте представлены ведущие мировые производители активных и пассивных электронных компонентов.

Нашей специализацией является поставка электронной компонентной базы двойного назначения, продукции таких производителей как XILINX, Intel (ex.ALTERA), Vicor, Microchip, Texas Instruments, Analog Devices, Mini-Circuits, Amphenol, Glenair.

Сотрудничество с глобальными дистрибьюторами электронных компонентов, предоставляет возможность заказывать и получать с международных складов практически любой перечень компонентов в оптимальные для Вас сроки.

На всех этапах разработки и производства наши партнеры могут получить квалифицированную поддержку опытных инженеров.

Система менеджмента качества компании отвечает требованиям в соответствии с ГОСТ Р ИСО 9001, ГОСТ РВ 0015-002 и ЭС РД 009

Офис по работе с юридическими лицами:

105318, г.Москва, ул.Щербаковская д.3, офис 1107, 1118, ДЦ «Щербаковский»

Телефон: +7 495 668-12-70 (многоканальный)

Факс: +7 495 668-12-70 (доб.304)

E-mail: info@moschip.ru

Skype отдела продаж:

moschip.ru

moschip.ru_4

moschip.ru_6

moschip.ru_9